

SPECIFICATION FOR APPROVAL

CUSTOMER: _____

CUST P/N: _____

BESOFTP/N: _____

DESC: **Φ20.5x39-10Ts-0.08x24*2P-20mm-CLB**

DATE: **2023/11/16**

Version: **A.0**

PREPARED BY	CHECKED BY	APPROVED BY	CUSTOMER APPROVE
Feng. Bo. Qun	Su. Yan. Ping	Qian. Li. Mou	

Company Name: Shenzhen Taosoft Electronics Co.Ltd.

Factory Address: Building701, Building10, BDistrict, Five Wing Industrial Zone, Guangming District, Shenzhen

TEL: 13824883512

Version Change History

Rev.	Before Change	After Change	Change Date	Approved By
A.0	New release	----	2023/11/16	Qian. Li. Mou

SPECIFICATION

DESC:	Φ20.5x39-10Ts-0.08x24*2P*20mm-CLB	Rev: A 0	CUST:	
			Fine P/N:	
			CUST P/N:	

One、 DIMENSION:(mm)

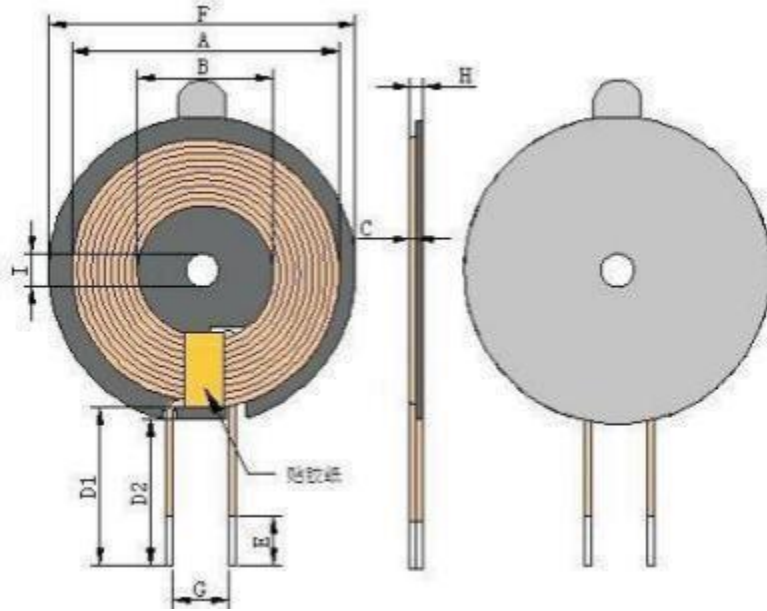

A	39.0 ± 1
B	20.5 ± 0.5
C	0.8 ± 0.05
D1	21 ± 2
D2	20 ± 2
E	3-1.5mm
F	43.5 ± 0.5
G	11.0 ref
H	1.5 ± 0.2 Max
I	5.0 ref

Notes:
 1.Coil tape magnet, film size 43.5 ± 0.5mm, inner hole 5.0mm, thickness 0.8 ± 0.1mm, straight slot
 2.Coil Out Location Width 8mm ± 0.5 High Temperature Glum Paper.
 3.The back of the tape is taped with hand tear in circular diameter 41.5mm(ref), inner hole 7.0(ref) ordinary double-sided glue. mm

Two、 SCHEMATIC DIAGRAM:

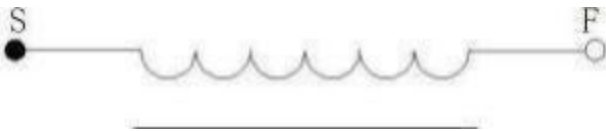

Three、 Winding Specification:

NO	TERMINAL	WIRE	Turns	Winding Direction
1	S F	Hot Wind Line :0.08*24*2P	10Ts	CCW

Four、 ELECTRICAL CHARACTERISTICS:

TEMPERATURE :25 ± 10 ° C, RELATIVE HUMIDITY :65 ± 20 %

NO	ITEM	TERMINAL	SPECIFICATION	TEST FREQUENCY	TEST EQUIPMENTS
1	IND.	S-F	3.0uH ± 20% Single coil	100KHz/ 1.0V	LCZ METER 1062B
2	IND.	S-F	6.5 uH ± 10% Add magnets	100KHz/ 1.0V	LCZ METER 1062B
3	Q Value	S-F	≤ 80(ref) Add magnets	100KHz/ 1.0V	LCZ METER 1062B
4	DCR	S-F	≤ 70m Ω		LCZ METER 502 B

PREPARED BY/DATE	CHECKED BY/DATE
Feng. Bo. Qun 2023/11/16	Su. Yan. Ping 2023/11/16

SPECIFICATION

DESC:	20.5x39-10Ts-0.08x24*2P-20mm-CLB	Rev: A 0	CUST:	
			Fine P/N:	
			CUST P/N:	

5. PACKONG:
5. Packing pictures:

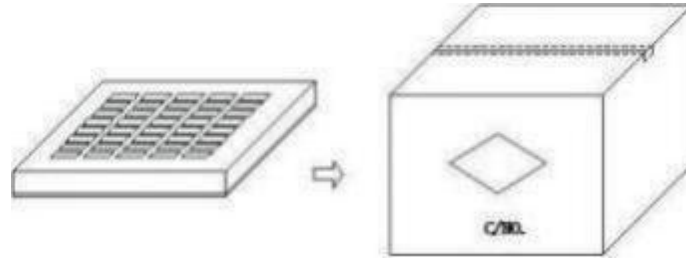

5.2 Packing Quantity:

Item	Quantity	Material
Box	350 Pcs	370*265*55mm
Big Carton	1400 Pcs	390*270*245mm

5. The packaging shall be based on the existing packing plate and the actual delivery package shall prevail. If there is any requirement, we can customize it.

Six、 Material list:

number	Material name	Description	Manufacturer
1	Hot Wind Line 0.08*24*2P	Hot Wind Line 0.08*24*2P	Dongguan King Source Electronic Materials CO., LTD
2	Lead-free tin strip	Lead-free tin strip	Shenzhen Daoqin Tin Industry Co. LTD
3	The magnet	Φ43.5*5.0*0.8mm Manganese HardThe magnet	Guangzhou Ruijing New Material Technology Co. LTD
4	Glue	201 Glue	Dongguan Feiquan Electronic Material Co. LTD
5	High temperature giue paper	8mm WideHigh temperature giue paper	Dong Guan Zhixing Tape New Material C
6	Double-sided glue with hole	Round diameter 41.5mm(ref)Back glue	Shenzhen Hongweida Technology Company., Ltd.

PREPARED BY/DATE	CHECKED BY/DATE
Feng. Bo. Qun 2023/11/16	Su. Yan. Ping 2023/11/16