

# 承认书

客户名称: Customer name: 华科诚

客户料号: Customer data: 19.10.03.7081U22

我司型号: Our model number: RC-G25-2.5-7.8UH-3500GS-5MM

送样日期: Sample delivery date: 2024年6月27日

供应方: Supply side: 东莞捷瑞思科技有限公司

|            |          |                       |
|------------|----------|-----------------------|
| 绘制 Draw up | 审核 Audit | 批准 Permission granted |
| 陆琳         | 邓祥桂      | 茹圣                    |

客户承认: Client acknowledges:

|              |                  |             |
|--------------|------------------|-------------|
| 合格 Qualified | 不合格 Disqualified | 承认 Admit it |
| 备注 Notes     |                  |             |

东莞捷瑞思科技有限公司

Dongguan Jerice Technology Co., Ltd.

Tel: \_\_\_\_\_

Fax: 86+13632701380

Address: No.96 Longhu Road, Dalingshan Town, Dongguan City

| 客户名称<br>Customer name | 客户料号<br>Customer data | 我司型号<br>Our model number    | 版本<br>Version | 日期<br>Date |
|-----------------------|-----------------------|-----------------------------|---------------|------------|
| 华科诚                   | 19.10.03.7081U22      | RC-G25-2.5-7.8UH-3500GS-5MM | A0            | 2024.06.27 |

一、平面结构图： 单位:MM Floor plan: unit: MM

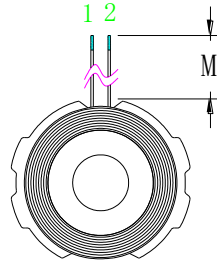
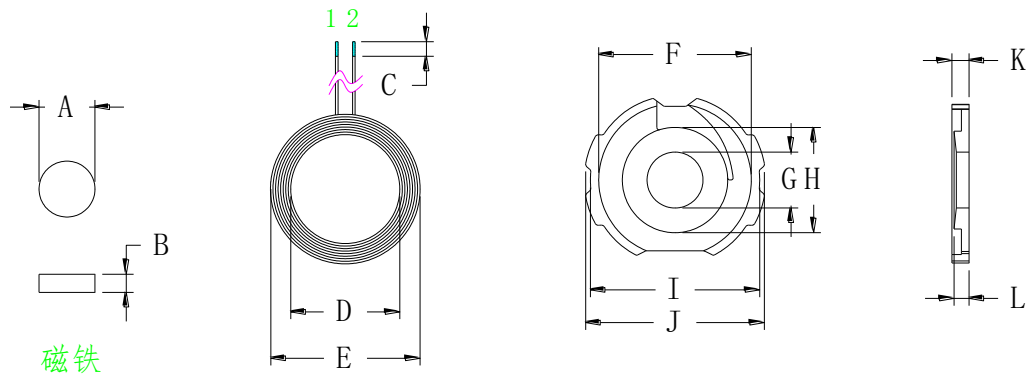

|   |                    |
|---|--------------------|
| A | $7.4 \pm 0.1$      |
| B | $2.3 \pm 0.1$      |
| C | $2 \pm 1$          |
| D | $14 \pm 0.2$       |
| E | $20.7 \pm 0.3$     |
| F | $21 \pm 0.2$       |
| G | $7.5 \pm 0.1$      |
| H | $13.5 \pm 0.2$     |
| I | $23.5 \pm 0.3$     |
| J | $25 \pm 0.3$       |
| K | $2.5 \pm 0.15$     |
| L | $2.4 \pm 0.1$ 中柱高度 |
| M | $5 \pm 1$          |

二、产品参数： Product parameters:

| 脚位 Feet | 线径 Line diameter | 圈数 Number of turns | 备注 Notes             |
|---------|------------------|--------------------|----------------------|
| 1- 2    | 0.08*24P         | 14                 | 热风绞合线 Hot Air Strand |

---

### 三、技术要求： Technical Requirements:

1. 把铜线的头和尾固定，防止铜线松或者断等现象。

Fix the head and tail of the copper wire to prevent loose or broken copper wire.

2. 按客户要求把多余的铜线的头部剪去，镀上锡，镀锡的深度为 1~3 mm。

According to customer requirements to cut the head of the excess copper wire, tinned, tinned depth of 1 ~ 3mm.

3. 在软的磁性片状物品上粘一些白胶，贴上铜线圈，在这过程中保证产品表面干净整洁。

Stick some white glue on the soft magnetic sheet and stick on the copper coil to ensure the clean and tidy surface of the product in the process.

4. 软的磁性片状物品上有圆孔，没有破损。

Soft magnetic flaky objects have round holes and are not damaged.

5. 附加工序（按客户要求）：在成品中间的圆孔装上 7.4x2.3mm 的磁铁，和在成品的背后再贴上直径为 14mm 的圆的双面胶，最后包装。

Additional process (according to customer requirements) : in the finished product in the middle of the round hole loaded with 7.4 x 2.3 mm magnet, and in the back of the finished product and then paste a diameter of 14 mm round double-sided adhesive, and finally packaging.

### 四、电性参数： Electrical parameter:

1. 电感值，Q 值： Inductance value,

$$PIN \quad 1 - 2 = 7.8\mu H \pm 0.2\mu H$$

$$Q \text{ 值} \geq 25$$

以上电感值以铨华 1062A 仪器，以 10KHZ/0.3Vrms 为标准或等同仪器。

Q 值以铨华 1062A 仪器，以 100KHZ/0.3Vrms 为标准或等同仪器

The above inductance values are based on chuanhua 1062A instrument, using 10KHZ/0.3 vrms as the standard or equivalent instrument. The Q value is based on chuanhua 1062A instrument and 100KHZ/0.3 vrms or equivalent instrument

五、材料清单： Bill of materials:

| 序号 NO | 名称 Name                  | 材质 Material Quality                               | 供应商 Suppliers                      | 备注 Notes |
|-------|--------------------------|---|------------------------------------|----------|
| 1     | 热风绞合线 Hot Air Strand     | 0.08X24P  | 维汉或等同 Uyghur or equivalent         |          |
| 2     | 磁片 Disk                  | G25 软基材<br>Soft substrate                         | 天通或等同 TX or equivalent             |          |
| 3     | 锡 Tin                    | 高温环保<br>High temperature environmental protection | 千岛或等同 Thond Island or equivalent   |          |
| 4     | 白胶<br>White glue         | BY882   | 宝月或等同 Treasure month or equivalent |          |
| 5     | 强磁 Strong magnetism      | 强度 7.4*2.3 strength<br>3500GS                     | 联胜或等同 Win-win or equal             |          |
| 6     | 双面胶<br>Double-sided glue | 直径 14mm<br>The diameter is 14 mm                  | 鸿辉或同等<br>Hung Fai or equivalent    |          |
|       |                          |   |                                    |          |
|       |                          |   |                                    |          |
|       |                          |   |                                    |          |

