



FCC&IC TEST REPORT

FCC ID: 2BA3P-P3

IC: 30492-P3

On Behalf of

GUANGZHOU MERCURY NAVIGATION TECHNOLOGY CO., LTD

P3 Handheld

Model No.: P3, P31, C3, C4, C5, C6, C7, C8, C9

Prepared for : GUANGZHOU MERCURY NAVIGATION TECHNOLOGY CO., LTD
Address : Room C401-403, TOPS Beidou Innovation Base, No.83, Kaiyuan
Avenue, Huangpu, Guangzhou, Guangdong, China

Prepared By : Shenzhen Alpha Product Testing Co., Ltd.
Address : Building i, No.2, Lixin Road, Fuyong Street, Bao'an District, 518103,
Shenzhen, Guangdong, China

Report Number : A2310171-C01-R17
Date of Receipt : October 27, 2023
Date of Test : October 27, 2023-December 12, 2023
Date of Report : December 16, 2023
Version Number : V0
Test Result : Pass

TABLE OF CONTENTS

| Description | Page |
|---|-----------|
| 1. Summary of Standards And Results | 5 |
| 1.1. Description of Standards and Results | 5 |
| 2. General Information | 6 |
| 2.1. Description of Device (EUT) | 6 |
| 2.2. Accessories of Device (EUT) | 7 |
| 2.3. Tested Supporting System Details | 7 |
| 2.4. Block Diagram of connection between EUT and simulators | 7 |
| 2.5. Test Mode Description | 7 |
| 2.6. Test Conditions | 8 |
| 2.7. Test Facility | 8 |
| 2.8. Measurement Uncertainty | 8 |
| 2.9. Test Equipment List | 9 |
| 3. Spurious Emission | 10 |
| 3.1. Test Limits | 10 |
| 3.2. Test Procedure | 12 |
| 3.3. Test Setup | 13 |
| 3.4. Test Results | 14 |
| 4. Power Line Conducted Emission | 22 |
| 4.1. Test Limits | 22 |
| 4.2. Test Procedure | 22 |
| 4.3. Test Setup | 22 |
| 4.4. Test Results | 22 |
| 5. Conducted Maximum Output Power | 25 |
| 5.1. Test limits | 25 |
| 5.2. Test Procedure | 25 |
| 5.3. Test Setup | 25 |
| 5.4. Test Results | 25 |
| 6. Peak Power Spectral Density | 26 |
| 6.1. Test limits | 26 |
| 6.2. Test Procedure | 26 |
| 6.3. Test Setup | 26 |
| 6.4. Test Results | 26 |
| 7. Bandwidth | 30 |
| 7.1. Test limits | 30 |
| 7.2. Test Procedure | 30 |
| 7.3. Test Setup | 30 |
| 7.4. Test Results | 30 |
| 8. Band Edge Check | 38 |
| 8.1. Test limits | 38 |
| 8.2. Test Procedure | 38 |
| 8.3. Test Setup | 38 |
| 8.4. Test Results | 38 |
| 9. Frequency stability | 42 |
| 9.1. Test limit | 42 |
| 9.2. Test Procedure | 42 |
| 9.3. Test Setup | 42 |
| 9.4. Test Results | 42 |
| 10. Antenna Requirement | 44 |
| 10.1. Standard Requirement | 44 |
| 10.2. Antenna Connected Construction | 44 |
| 10.3. Results | 44 |
| 11. Test setup photo | 45 |
| 11.1. Photo of Radiated Emission test | 45 |
| 11.2. Photo of Conducted Emission test | 46 |

TEST REPORT DECLARATION

Applicant : GUANGZHOU MERCURY NAVIGATION TECHNOLOGY CO., LTD
 Address : Room C401-403, TOPS Beidou Innovation Base, No.83, Kaiyuan Avenue, Huangpu, Guangzhou, Guangdong, China
 Manufacturer : GUANGZHOU MERCURY NAVIGATION TECHNOLOGY CO., LTD
 Address : Room C401-403, TOPS Beidou Innovation Base, No.83, Kaiyuan Avenue, Huangpu, Guangzhou, Guangdong, China
 EUT Description : P3 Handheld
 (A) Model No. P3, P31, C3, C4, C5, C6, C7, C8, C9
 (B) Trademark N/A

Measurement Standard Used:

FCC Rules and Regulations Part 15 Subpart C Section 15.247
RSS-247 Issue 2, RSS-Gen Issue 5, ANSI C63.10:2013, CISPR 16-1-4:2010

The device described above is tested by Shenzhen Alpha Product Testing Co., Ltd. to determine the maximum emission levels emanating from the device. The maximum emission levels are compared to the FCC Part 15 Subpart C limits both conducted and radiated emissions. The test results are contained in this test report and Shenzhen Alpha Product Testing Co., Ltd. is assumed of full responsibility for the accuracy and completeness of these tests.

After the test, our opinion is that EUT compliance with the requirement of the above standards.

This report applies to above tested sample only. This report shall not be reproduced in parts without written approval of Shenzhen Alpha Product Testing Co., Ltd.

Tested by (name + signature).....: Yannis Wen
 Project Engineer



Approved by (name + signature).....: Reak Yang
 Project Manager



Date of issue.....: December 16, 2023

Revision History

| Revision | Issue Date | Revisions | Revised By |
|----------|-------------------|------------------------|------------|
| V0 | November 16, 2022 | Initial released Issue | Yannis Wen |

1. SUMMARY OF STANDARDS AND RESULTS

1.1. Description of Standards and Results

The EUT have been tested according to the applicable standards as referenced below:

| Test Item | Standards Paragraph | Result |
|---|---|--------|
| Conducted Emission | FCC Part 15: 15.207 RSS-GEN(8.8), ANSI C63.10 :2013 | P |
| 6dB Bandwidth | FCC PART 15:15.247(a)(2) RSS-247(5.2 a), ANSI C63.10 :2013 | P |
| Output Power | FCC Part 15: 15.247(b)(3) RSS-247(5.4 d), ANSI C63.10 :2013 | P |
| Radiated Spurious Emission | FCC Part 15: 15.209, FCC Part 15: 15.247(d) RSS-Gen(8.9), RSS-247(5.5), ANSI C63.10 :2013 | P |
| Conducted Spurious & Band Edge Emission | FCC Part 15: 15.247(d) RSS-Gen(8.9), RSS-247(5.5), ANSI C63.10 :2013 | P |
| Power Spectral Density | FCC PART 15:15.247(e) RSS-247(5.2 b), ANSI C63.10 :2013 | P |
| Radiated Band Edge Emission | FCC Part 15: 15.247(d) RSS-GEN(6.13), ANSI C63.10 :2013 | P |
| Frequency stability | RSS-GEN(6.11) | P |
| Antenna Requirement | FCC Part 15: 15.203 RSS-GEN(6.8) | P |
| Note: | 1. P is an abbreviation for Pass. 2. F is an abbreviation for Fail. 3. N/A is an abbreviation for Not Applicable. | |

1. Pass: The EUT complies with the essential requirements in the standard.
2. Frequency Stability: The manufacturer stated in the user's manual.
3. The conclusion of this test report is judged by actual test data without considering measurement uncertainty.

2. GENERAL INFORMATION

2.1. Description of Device (EUT)

| | |
|------------------------|---|
| Description | : P3 Handheld |
| Model Number | : P3, P31, C3, C4, C5, C6, C7, C8, C9 |
| Diff | : There is no difference except the name of the model. All tests are made with the P3 model. |
| Power supply | : DC 5V/9V from adapter with AC 120V/60Hz, DC 3.8V from battery |
| Radio Technology | : Bluetooth V5.0 BLE |
| Operation frequency | : 2402-2480MHz |
| Channel No. | : 40 Channels |
| Channel spacing | : 2MHz |
| Rate | : 1Mbps, 2Mbps |
| Modulation type | : GFSK |
| Antenna Type | : Internal antenna, Maximum Gain is 1.75dBi. Antenna information is provided by applicant. |
| Software version | : P3B_080 |
| Hardware version | : P3 MB V2.0 |
| Connector cable loss | : N/A |
| Intend use environment | : Residential, commercial and light industrial environment |

2.2. Accessories of Device (EUT)

Accessories : Switching Adapter
 Manufacturer : DEE VAN ENTERPRISE CO., LTD.
 Model : DSA-45PDH
 INPUT : 100-240V~50/60Hz 1.5A
 OUTPUT : +5.0V = 3.0A, 15.0W; +9.0V = 3.0A, 27W; +12.0V = 3.0A, 36.0W;
 +15.0V = 3.0A, 45.0W; +20V = 2.25A, 45.0W

2.3. Tested Supporting System Details

| No. | Description | Manufacturer | Model | Serial Number | Certification or SDoC |
|-----|-------------|--------------|-------|---------------|-----------------------|
| 1 | -- | -- | -- | -- | -- |

2.4. Block Diagram of connection between EUT and simulators

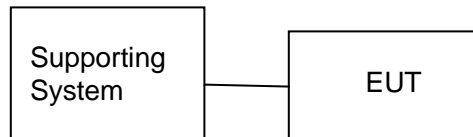

2.5. Test Mode Description

| Tested mode, channel, and data rate information | | |
|---|--------------|-----------------|
| Mode | Channel | Frequency (MHz) |
| GFSK (1Mbps, 2Mbps) | Low :CH1 | 2402 |
| | Middle: CH20 | 2440 |
| | High: CH40 | 2480 |

2.6. Test Conditions

| Items | Required | Actual |
|--------------------|-----------|--------|
| Temperature range: | 15-35°C | 24°C |
| Humidity range: | 25-75% | 56% |
| Pressure range: | 86-106kPa | 980kPa |

2.7. Test Facility

Shenzhen Alpha Product Testing Co., Ltd
 Building i, No.2, Lixin Road, Fuyong Street, Bao'an District, 518103,
 Shenzhen, Guangdong, China

June 21, 2018 File on Federal Communication Commission
 Registration Number: 293961

July 25, 2017 Certificated by IC
 Registration Number: CN0085

2.8. Measurement Uncertainty

(95% confidence levels, k=2)

| Item | Uncertainty |
|--|---------------------------|
| Uncertainty for Power point Conducted Emissions Test | 1.63dB |
| Uncertainty for Radiation Emission test in 3m chamber (below 30MHz) | 3.5dB |
| Uncertainty for Radiation Emission test in 3m chamber (30MHz to 1GHz) | 3.74dB(Polarize: V) |
| | 3.76dB(Polarize: H) |
| Uncertainty for Radiation Emission test in 3m chamber (1GHz to 25GHz) | 3.77dB(Polarize: V) |
| | 3.80dB(Polarize: H) |
| Uncertainty for Radiation Emission test in 3m chamber (18GHz to 40GHz) | 4.31 dB(Polarize: V) |
| | 4.30 dB(Polarize: H) |
| Uncertainty for radio frequency | 5.06×10^{-8} GHz |
| Uncertainty for conducted RF Power | 0.40dB |
| Uncertainty for temperature | 0.2°C |
| Uncertainty for humidity | 1% |
| Uncertainty for DC and low frequency voltages | 0.06% |

2.9. Test Equipment List

| Equipment | Manufacture | Model No. | Firmware version | Serial No. | Last cal. | Cal Interval |
|-----------------------------|---------------|------------------|------------------|----------------------------|------------|--------------|
| 9*6*6 anechoic chamber | CHENYU | 9*6*6 | / | N/A | 2022.05.17 | 3Year |
| Spectrum analyzer | ROHDE&SCHWARZ | FSV40-N | 2.3 | 102137 | 2023.08.16 | 1Year |
| Spectrum analyzer | Agilent | N9020A | A.14.16 | MY499100060 | 2023.08.16 | 1Year |
| Receiver | ROHDE&SCHWARZ | ESR | 2.28 SP1 | 1316.3003K03-10 2082-Wa | 2023.08.16 | 1Year |
| Receiver | R&S | ESCI | 4.42 SP1 | 101165 | 2023.08.16 | 1Year |
| Bilog Antenna | Schwarzbeck | VULB 9168 | / | VULB 9168#627 | 2023.08.28 | 1Year |
| Horn Antenna | SCHWARZBECK | BBHA 9120 D | / | 2106 | 2023.08.19 | 1Year |
| Loop Antenna | SCHWARZBECK | FMZB 1519B | / | 00128 | 2023.08.19 | 1Year |
| RF Cable | Resenberger | Cable 1 | / | RE1 | 2023.08.16 | 1Year |
| RF Cable | Resenberger | Cable 2 | / | RE2 | 2023.08.16 | 1Year |
| RF Cable | Resenberger | Cable 3 | / | CE1 | 2023.08.16 | 1Year |
| Pre-amplifier | HP | HP8347A | / | 2834A00455 | 2023.08.16 | 1Year |
| Pre-amplifier | Agilent | 8449B | / | 3008A02664 | 2023.08.16 | 1Year |
| L.I.S.N.#1 | Schwarzbeck | NSLK8126 | / | 8126-466 | 2023.08.16 | 1Year |
| L.I.S.N.#2 | ROHDE&SCHWARZ | ENV216 | / | 101043 | 2023.08.16 | 1Year |
| Horn Antenna | SCHWARZBECK | BBHA 9170 | / | 00946 | 2023.08.19 | 1Year |
| Preamplifier | SKET | LNPA_1840 -50 | / | SK2018101801 | 2023.08.16 | 1 Year |
| Power Meter | Agilent | E9300A | / | MY41496628 | 2023.08.16 | 1 Year |
| Power Sensor | DARE | RPR3006W | / | 15100041SNO91 | 2023.08.16 | 1 Year |
| Temp. & Humid. Chamber | Teelong | TL-HW408S | / | TL-20191205-01 | 2023.07.25 | 1 Year |
| Switching Mode Power Supply | JUNKE | JK12010S | / | 20140927-6 | 2023.08.16 | 1 Year |
| Adjustable attenuator | MWRFtest | N/A | / | N/A | N/A | N/A |
| 10dB Attenuator | Mini-Circuits | DC-6G | / | N/A | N/A | N/A |

Software Information

| Test Item | Software Name | Manufacturer | Version |
|-----------|---------------|--------------|-----------|
| RE | EZ-EMC | EZ | Alpha-3A1 |
| CE | EZ-EMC | EZ | Alpha-3A1 |
| RF-CE | MTS 8310 | MW | V2.0.0.0 |

3. SPURIOUS EMISSION

3.1. Test Limits

All the emissions appearing within 15.205 restricted frequency bands shall not exceed the limits shown in 15.209, all the other emissions shall be at least 20dB below the fundamental emissions, or comply with 15.209 limits.

15.205 Restricted frequency band

| MHz | MHz | MHz | GHz |
|----------------------------|-----------------------|-----------------|------------------|
| 0.090 - 0.110 | 16.42 - 16.423 | 399.9 - 410 | 4.5 - 5.15 |
| ¹ 0.495 - 0.505 | 16.69475 - 16.69525 | 608 - 614 | 5.35 - 5.46 |
| 2.1735 - 2.1905 | 16.80425 - 16.80475 | 960 - 1240 | 7.25 - 7.75 |
| 4.125 - 4.128 | 25.5 - 25.67 | 1300 - 1427 | 8.025 - 8.5 |
| 4.17725 - 4.17775 | 37.5 - 38.25 | 1435 - 1626.5 | 9.0 - 9.2 |
| 4.20725 - 4.20775 | 73 - 74.6 | 1645.5 - 1646.5 | 9.3 - 9.5 |
| 6.215 - 6.218 | 74.8 - 75.2 | 1660 - 1710 | 10.6 - 12.7 |
| 6.26775 - 6.26825 | 108 - 121.94 | 1718.8 - 1722.2 | 13.25 - 13.4 |
| 6.31175 - 6.31225 | 123 - 138 | 2200 - 2300 | 14.47 - 14.5 |
| 8.291 - 8.294 | 149.9 - 150.05 | 2310 - 2390 | 15.35 - 16.2 |
| 8.362 - 8.366 | 156.52475 - 156.52525 | 2483.5 - 2500 | 17.7 - 21.4 |
| 8.37625 - 8.38675 | 156.7 - 156.9 | 2690 - 2900 | 22.01 - 23.12 |
| 8.41425 - 8.41475 | 162.0125 - 167.17 | 3260 - 3267 | 23.6 - 24.0 |
| 12.29 - 12.293 | 167.72 - 173.2 | 3332 - 3339 | 31.2 - 31.8 |
| 12.51975 - 12.52025 | 240 - 285 | 3345.8 - 3358 | 36.43 - 36.5 |
| 12.57675 - 12.57725 | 322 - 335.4 | 3600 - 4400 | (²) |

RSS-GEN Restricted frequency band

Table 7 – Restricted frequency bands^{Note 1}

| MHz | MHz | GHz |
|-------------------|-----------------------|---------------|
| 0.090 - 0.110 | 149.9 - 150.05 | 9.0 - 9.2 |
| 0.495 - 0.505 | 156.52475 - 156.52525 | 9.3 - 9.5 |
| 2.1735 - 2.1905 | 156.7 - 156.9 | 10.6 - 12.7 |
| 3.020 - 3.026 | 162.0125 - 167.17 | 13.25 - 13.4 |
| 4.125 - 4.128 | 167.72 - 173.2 | 14.47 - 14.5 |
| 4.17725 - 4.17775 | 240 - 285 | 15.35 - 16.2 |
| 4.20725 - 4.20775 | 322 - 335.4 | 17.7 - 21.4 |
| 5.677 - 5.683 | 399.9 - 410 | 22.01 - 23.12 |
| 6.215 - 6.218 | 608 - 614 | 23.6 - 24.0 |

| | | |
|---------------------|-----------------|--------------|
| 6.26775 - 6.26825 | 960 - 1427 | 31.2 - 31.8 |
| 6.31175 - 6.31225 | 1435 - 1626.5 | 36.43 - 36.5 |
| 8.291 - 8.294 | 1645.5 - 1646.5 | Above 38.6 |
| 8.362 - 8.366 | 1660 - 1710 | |
| 8.37625 - 8.38675 | 1718.8 - 1722.2 | |
| 8.41425 - 8.41475 | 2200 - 2300 | |
| 12.29 - 12.293 | 2310 - 2390 | |
| 12.51975 - 12.52025 | 2483.5 - 2500 | |
| 12.57675 - 12.57725 | 2655 - 2900 | |
| 13.36 - 13.41 | 3260 – 3267 | |
| 16.42 - 16.423 | 3332 - 3339 | |
| 16.69475 - 16.69525 | 3345.8 - 3358 | |
| 16.80425 - 16.80475 | 3500 - 4400 | |
| 25.5 - 25.67 | 4500 - 5150 | |
| 37.5 - 38.25 | 5350 - 5460 | |
| 73 - 74.6 | 7250 - 7750 | |
| 74.8 - 75.2 | 8025 – 8500 | |
| 108 – 138 | | |

Note 1: Certain frequency bands listed in table 7 and in bands above 38.6 GHz are designated for licence-exempt applications. These frequency bands and the requirements that apply to related devices are set out in the 200 and 300 series of RSSs.

15.209 Limit

| FREQUENCY MHz | DISTANCE Meters | FIELD STRENGTHS LIMIT | |
|---|--------------------|---|-----------------------------------|
| | | $\mu\text{V}/\text{m}$ | $\text{dB}(\mu\text{V})/\text{m}$ |
| 0.009-0.490 | 300 | 2400/F(KHz) | / |
| 0.490-1.705 | 30 | 24000/F(KHz) | / |
| 1.705-30 | 30 | 30 | 29.5 |
| 30 ~ 88 | 3 | 100 | 40.0 |
| 88 ~ 216 | 3 | 150 | 43.5 |
| 216 ~ 960 | 3 | 200 | 46.0 |
| 960 ~ 1000 | 3 | 500 | 54.0 |
| Above 1000 | 3 | 74.0 dB(μV)/m (Peak) 54.0 dB(μV)/m (Average) | |
| Note 1: The peak limit is 20 dB higher than the average limit | | | |
| Note 2: Peak limit applies (AVG limit + 20 dB) as well as RSS-247 Section 5.5 | | | |

Harmonic emissions limits comply with below 54 dB $\mu\text{V}/\text{m}$ at 3m. Other emissions radiated outside of the specified frequency bands, except for harmonics, shall be attenuated by at least 50 dB below the level of the fundamental or comply with the radiated emissions limits specified in section 15.209(a) limit in the table below has to be followed.

Table 5 – General field strength limits at frequencies above 30 MHz

| Frequency (MHz) | Field strength ($\mu\text{V}/\text{m}$ at 3 m) |
|-----------------|---|
| 30 – 88 | 100 |
| 88 – 216 | 150 |
| 216 – 960 | 200 |
| Above 960 | 500 |

Table 6 – General field strength limits at frequencies below 30 MHz

| Frequency | Magnetic field strength (H-Field) ($\mu\text{A}/\text{m}$) | Measurement distance (m) |
|-------------------------------|--|--------------------------|
| 9 - 490 kHz ^{Note 1} | 6.37/F (F in kHz) | 300 |
| 490 - 1705 kHz | 63.7/F (F in kHz) | 30 |
| 1.705 - 30 MHz | 0.08 | 30 |

Note 1: The emission limits for the ranges 9-90 kHz and 110-490 kHz are based on measurements employing a linear average detector.

3.2. Test Procedure

The measuring distance of 3m shall be used for measurements at frequency up to 1GHz and above 1GHz, The EUT was placed on a rotating 0.8 m high above ground for below 1GHz and 1.5m high for above1GHz testing, The table was rotated 360 degrees to determine the position of the highest radiation

The Test antenna shall vary between 1m and 4m, Both Horizontal and Vertical antenna are set of make measurement.

The initial step in collecting conducted emission data is a spectrum analyzer Peak detector mode pre-scanning the measurement frequency range. Significant Peaks are then marked. and then Qusia Peak Detector mode premeasured

If Peak value comply with QP limit Below 1GHz.The EUT deemed to comply with QP limit. But the Peak value and average value both need to comply with applicable limit above 1GHz.

For the actual test setup, please see the test setup photo.

3.3. Test Setup

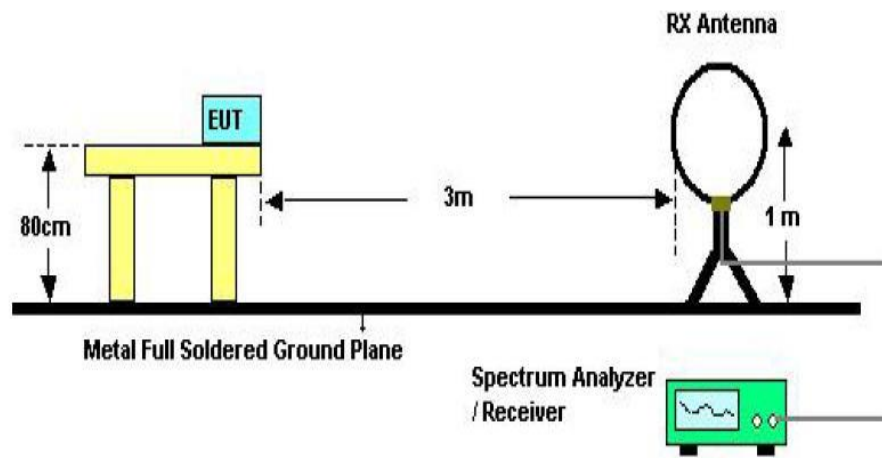

Below 30MHz Test Setup

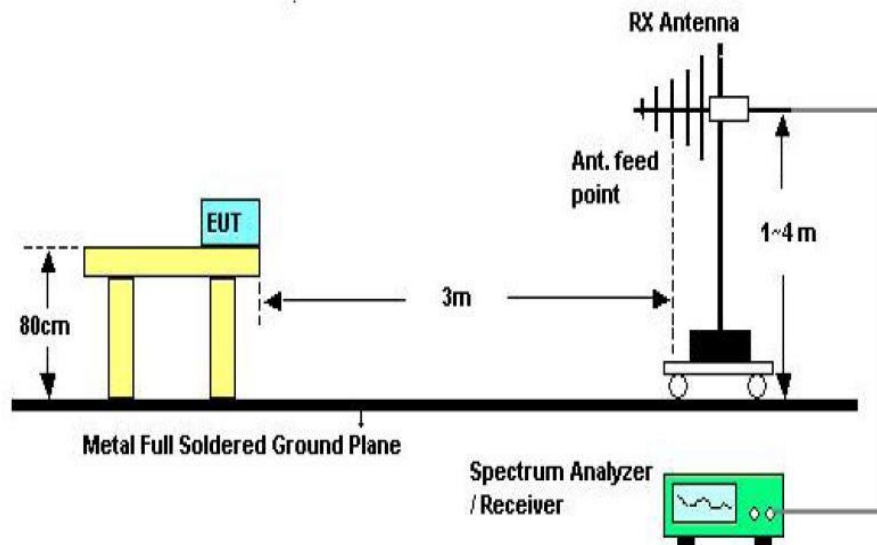

Above 30MHz Test Setup

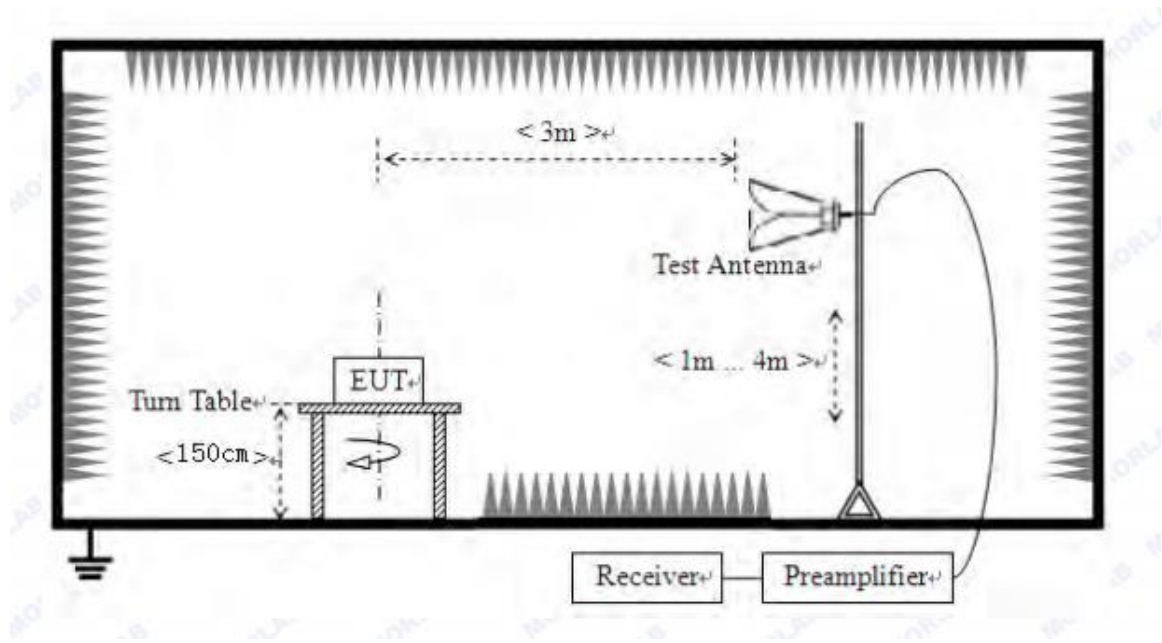

Above 1GHz Test Setup

3.4. Test Results

Test Condition

Continual Transmitting in maximum power.

| | | |
|--------------|-----------|------------|
| 9KHz~150KHz | RBW200Hz | VBW1KHz |
| 150KHz~30MHz | RBW9KHz | VBW 30KHz |
| 30MHZ~1GHz | RBW120KHz | VBW 300KHz |
| Above1GHz | RBW1MHz | VBW 3MHz |

We have scanned the 10th harmonic from 9 kHz to the EUT.

Detailed information please see the following page.

From 9KHz to 30MHz: Conclusion: PASS

Note: 1. The amplitude of spurious emissions which are attenuated by more than 20dB below the permissible value has no need to be reported.

2. Only show the test data of the worst Channel in this report.

Antenna polarity: Horizontal

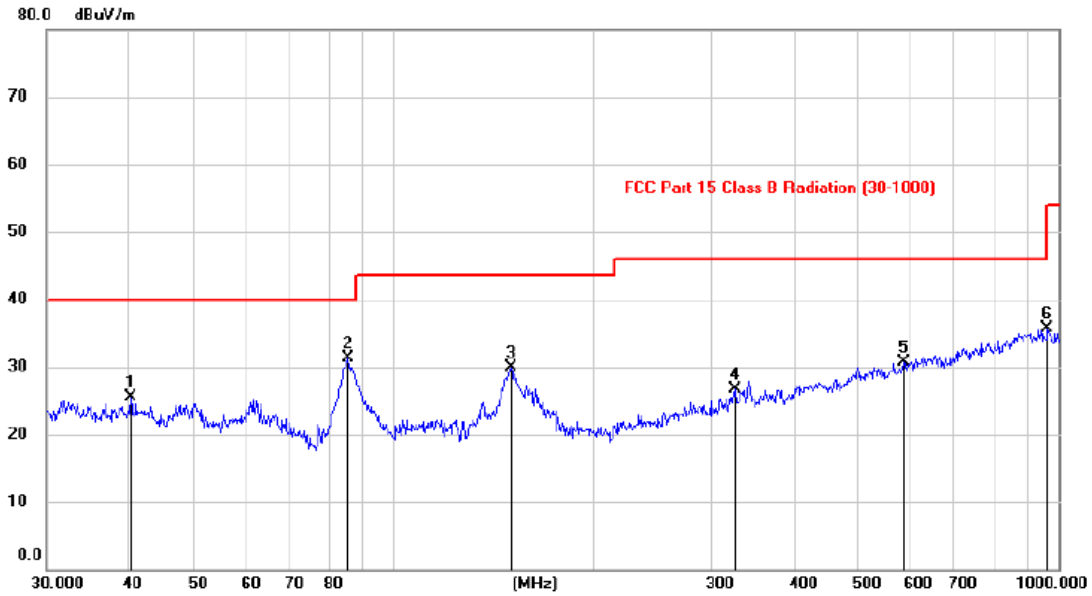

| No. | Mk. | Freq. | Reading Level | Correct Factor | Measurement | Limit | Margin | Antenna Height | Table Degree |
|-----|-----|----------|---------------|----------------|-------------|--------|--------|----------------|--------------|
| | | MHz | dBuV | dB | dBuV/m | dBuV/m | dB | cm | degree |
| 1 | | 40.1533 | 10.97 | 14.45 | 25.42 | 40.00 | -14.58 | | |
| 2 | * | 85.4676 | 21.32 | 9.98 | 31.30 | 40.00 | -8.70 | | |
| 3 | | 150.2915 | 14.79 | 15.06 | 29.85 | 43.50 | -13.65 | | |
| 4 | | 326.8158 | 11.89 | 14.76 | 26.65 | 46.00 | -19.35 | | |
| 5 | | 584.9945 | 10.85 | 19.92 | 30.77 | 46.00 | -15.23 | | |
| 6 | | 965.3164 | 11.01 | 24.69 | 35.70 | 54.00 | -18.30 | | |

Note: 1. *:Maximum data; x:Over limit; !:over margin.

2.Measurement=Reading Level+Correct Factor; Correct Factor=Antenna Factor+Cable Loss.

Antenna polarity: Vertical

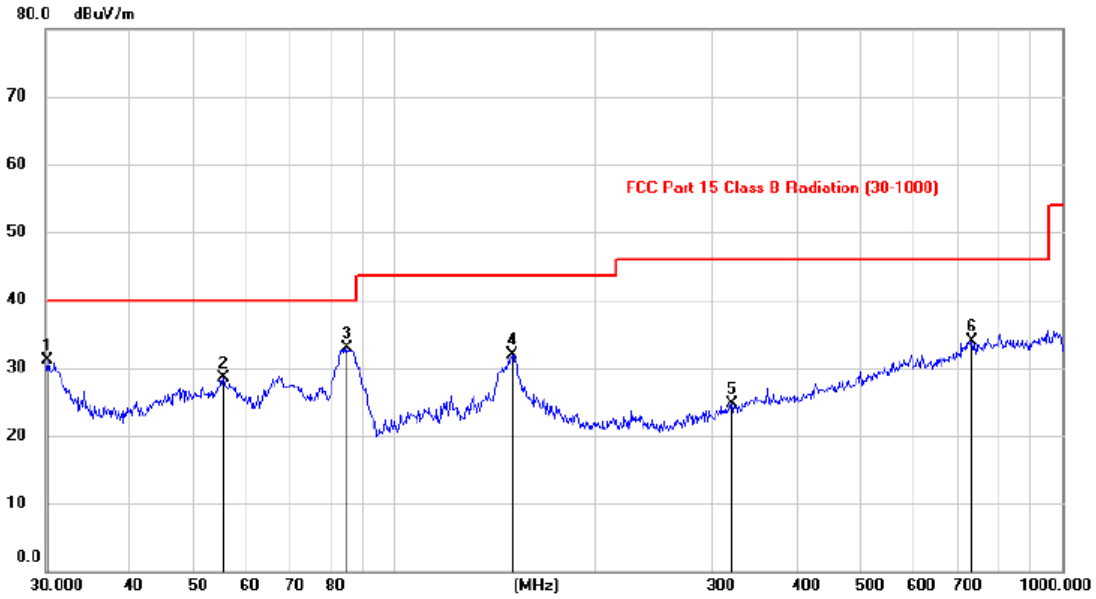

| No. | Mk. | Freq. MHz | Reading Level dBuV | Correct Factor dB | Measure- ment dBuV/m | Limit dBuV/m | Margin dB | Detector | Antenna Height cm | Table Degree | Comment |
|-----|-----|--------------|--------------------------|-------------------------|----------------------------|-----------------|--------------|----------|-------------------------|-----------------|---------|
| 1 | | 30.2783 | 17.48 | 13.54 | 31.02 | 40.00 | -8.98 | peak | | | |
| 2 | | 55.5962 | 15.01 | 13.57 | 28.58 | 40.00 | -11.42 | peak | | | |
| 3 | * | 84.8009 | 22.99 | 9.97 | 32.96 | 40.00 | -7.04 | peak | | | |
| 4 | | 150.3092 | 16.85 | 15.06 | 31.91 | 43.50 | -11.59 | peak | | | |
| 5 | | 320.1238 | 10.02 | 14.63 | 24.65 | 46.00 | -21.35 | peak | | | |
| 6 | | 733.2903 | 11.81 | 22.18 | 33.99 | 46.00 | -12.01 | peak | | | |

Note: 1. *:Maximum data; x:Over limit; !:over margin.

2.Measurement=Reading Level+Correct Factor; Correct Factor=Antenna Factor+Cable Loss.

Notes: Above is below 1GHz test data. This report only shall the worst case mode for GFSK 1M 2402MHz.

1Mbps
From 1G-25GHz

| Test Mode: TX Low | | | | | | | | | |
|---|---------------------|-------------|-----------------------|----------------|-----------------|-----------------|----------------|-------------|--------|
| Freq (MHz) | Read Level (dBuV/m) | Polar (H/V) | Antenna Factor (dB/m) | Cable loss(dB) | Amp Factor (dB) | Result (dBuV/m) | Limit (dBuV/m) | Margin (dB) | Remark |
| 4804 | 42.17 | V | 33.95 | 10.18 | 34.26 | 52.04 | 74 | -21.96 | PK |
| 4804 | 36.48 | V | 33.95 | 10.18 | 34.26 | 46.35 | 54 | -7.65 | AV |
| 7206 | / | / | / | / | / | / | / | / | / |
| 9608 | / | / | / | / | / | / | / | / | / |
| 4804 | 44.79 | H | 33.95 | 10.18 | 34.26 | 54.66 | 74 | -19.34 | PK |
| 4804 | 34.66 | H | 33.95 | 10.18 | 34.26 | 44.53 | 54 | -9.47 | AV |
| 7206 | / | / | / | / | / | / | / | / | / |
| 9608 | / | / | / | / | / | / | / | / | / |
| Test Mode: TX Mid | | | | | | | | | |
| 4880 | 42.96 | V | 33.93 | 10.2 | 34.29 | 52.80 | 74 | -21.20 | PK |
| 4880 | 33.27 | V | 33.93 | 10.2 | 34.29 | 43.11 | 54 | -10.89 | AV |
| 7320 | / | / | / | / | / | / | / | / | / |
| 9760 | / | / | / | / | / | / | / | / | / |
| 4880 | 43.25 | H | 33.93 | 10.2 | 34.29 | 53.09 | 74 | -20.91 | PK |
| 4880 | 34.37 | H | 33.93 | 10.2 | 34.29 | 44.21 | 54 | -9.79 | AV |
| 7320 | / | / | / | / | / | / | / | / | / |
| 9760 | / | / | / | / | / | / | / | / | / |
| Test Mode: TX High | | | | | | | | | |
| 4960 | 45.44 | V | 33.98 | 10.22 | 34.25 | 55.39 | 74 | -18.61 | PK |
| 4960 | 35.80 | V | 33.98 | 10.22 | 34.25 | 45.75 | 54 | -8.25 | AV |
| 7440 | / | / | / | / | / | / | / | / | / |
| 9920 | / | / | / | / | / | / | / | / | / |
| 4960 | 41.70 | H | 33.98 | 10.22 | 34.25 | 51.65 | 74 | -22.35 | PK |
| 4960 | 34.49 | H | 33.98 | 10.22 | 34.25 | 44.44 | 54 | -9.56 | AV |
| 7440 | / | / | / | / | / | / | / | / | / |
| 9920 | / | / | / | / | / | / | / | / | / |
| Note: | | | | | | | | | |
| 1, Result = Read level + Antenna factor + cable loss-Amp factor | | | | | | | | | |
| 2, All the other emissions not reported were too low to read and deemed to comply with FCC limit. | | | | | | | | | |

2Mbps
From 1G-25GHz

| Test Mode: TX Low | | | | | | | | | |
|---|---------------------|-------------|-----------------------|----------------|-----------------|-----------------|----------------|-------------|--------|
| Freq (MHz) | Read Level (dBuV/m) | Polar (H/V) | Antenna Factor (dB/m) | Cable loss(dB) | Amp Factor (dB) | Result (dBuV/m) | Limit (dBuV/m) | Margin (dB) | Remark |
| 4804 | 45.02 | V | 33.95 | 10.18 | 34.26 | 54.89 | 74 | -19.11 | PK |
| 4804 | 38.31 | V | 33.95 | 10.18 | 34.26 | 48.18 | 54 | -5.82 | AV |
| 7206 | / | / | / | / | / | / | / | / | / |
| 9608 | / | / | / | / | / | / | / | / | / |
| 4804 | 45.88 | H | 33.95 | 10.18 | 34.26 | 55.75 | 74 | -18.25 | PK |
| 4804 | 35.42 | H | 33.95 | 10.18 | 34.26 | 45.29 | 54 | -8.71 | AV |
| 7206 | / | / | / | / | / | / | / | / | / |
| 9608 | / | / | / | / | / | / | / | / | / |
| Test Mode: TX Mid | | | | | | | | | |
| 4880 | 42.80 | V | 33.93 | 10.2 | 34.29 | 52.64 | 74 | -21.36 | PK |
| 4880 | 36.48 | V | 33.93 | 10.2 | 34.29 | 46.32 | 54 | -7.68 | AV |
| 7320 | / | / | / | / | / | / | / | / | / |
| 9760 | / | / | / | / | / | / | / | / | / |
| 4880 | 45.63 | H | 33.93 | 10.2 | 34.29 | 55.47 | 74 | -18.53 | PK |
| 4880 | 34.80 | H | 33.93 | 10.2 | 34.29 | 44.64 | 54 | -9.36 | AV |
| 7320 | / | / | / | / | / | / | / | / | / |
| 9760 | / | / | / | / | / | / | / | / | / |
| Test Mode: TX High | | | | | | | | | |
| 4960 | 45.92 | V | 33.98 | 10.22 | 34.25 | 55.87 | 74 | -18.13 | PK |
| 4960 | 33.10 | V | 33.98 | 10.22 | 34.25 | 43.05 | 54 | -10.95 | AV |
| 7440 | / | / | / | / | / | / | / | / | / |
| 9920 | / | / | / | / | / | / | / | / | / |
| 4960 | 44.28 | H | 33.98 | 10.22 | 34.25 | 54.23 | 74 | -19.77 | PK |
| 4960 | 33.92 | H | 33.98 | 10.22 | 34.25 | 43.87 | 54 | -10.13 | AV |
| 7440 | / | / | / | / | / | / | / | / | / |
| 9920 | / | / | / | / | / | / | / | / | / |
| Note: 1, Result = Read level + Antenna factor + cable loss-Amp factor 2, All the other emissions not reported were too low to read and deemed to comply with FCC limit. | | | | | | | | | |

Conducted RF Spurious Emission

Tx. Spurious NVNT BLE 1M 2402MHz Ant1 Emission

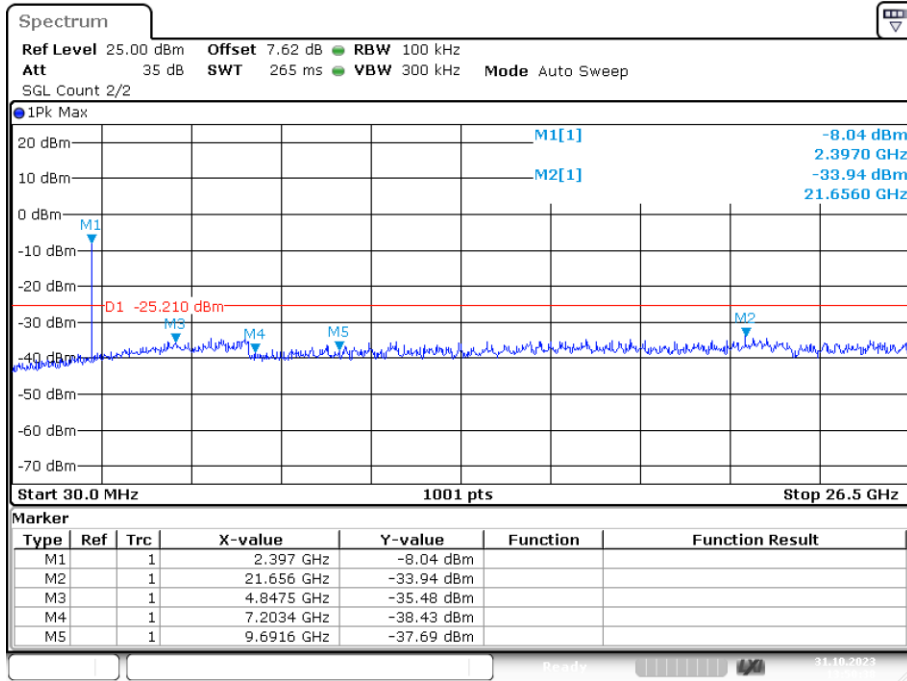

Tx. Spurious NVNT BLE 1M 2440MHz Ant1 Emission

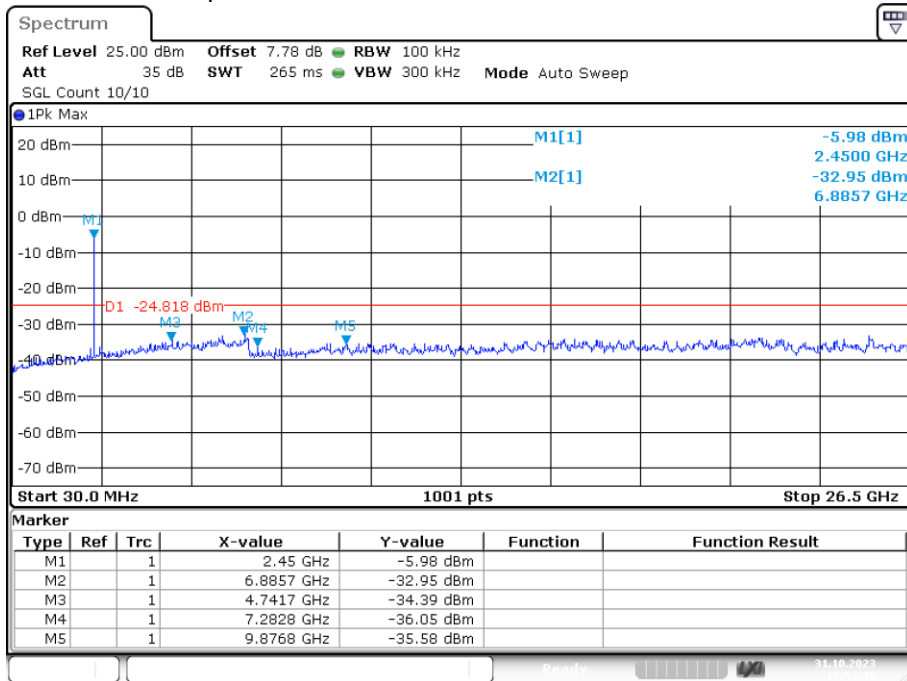

Tx. Spurious NVNT BLE 1M 2480MHz Ant1 Emission

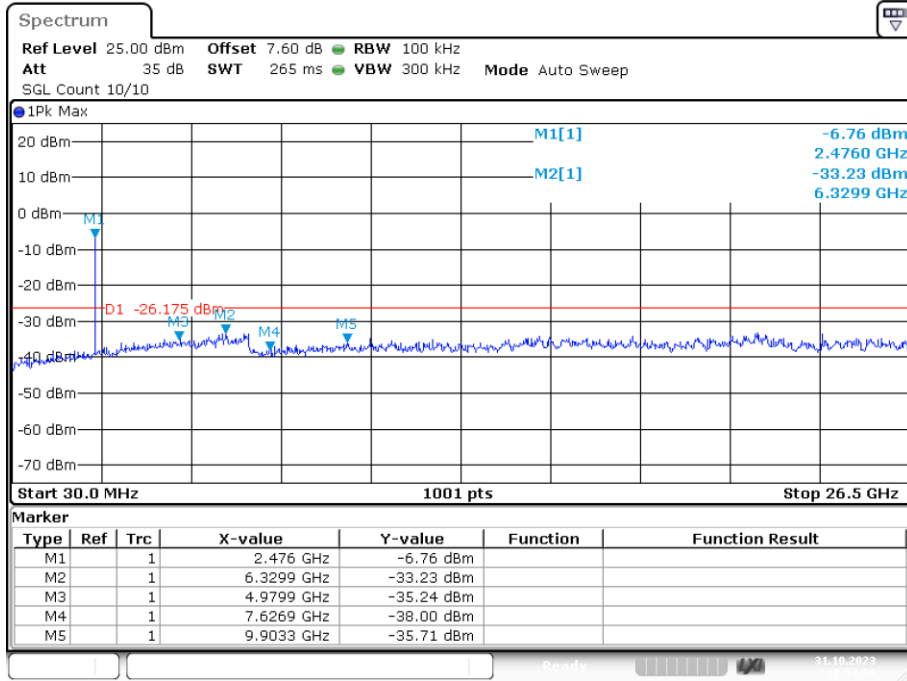

Tx. Spurious NVNT BLE 2M 2402MHz Ant1 Emission

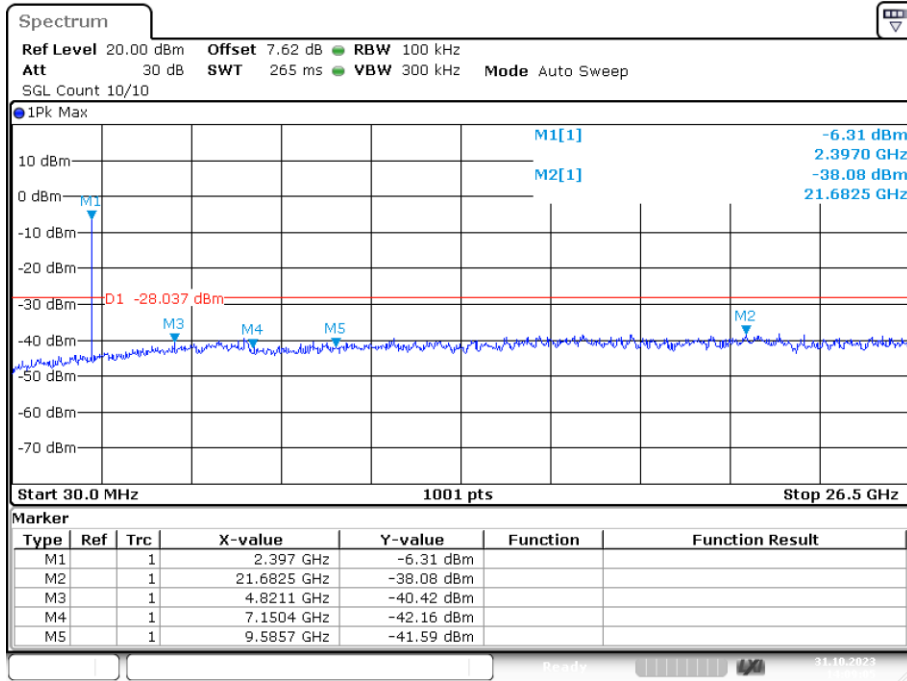

Tx. Spurious NVNT BLE 2M 2440MHz Ant1 Emission

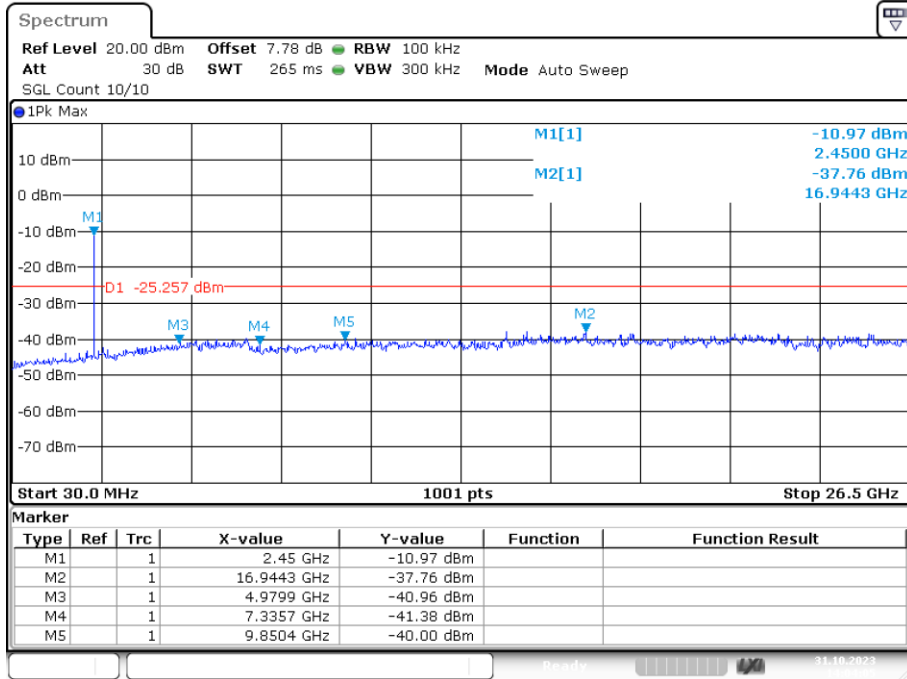

Tx. Spurious NVNT BLE 2M 2480MHz Ant1 Emission

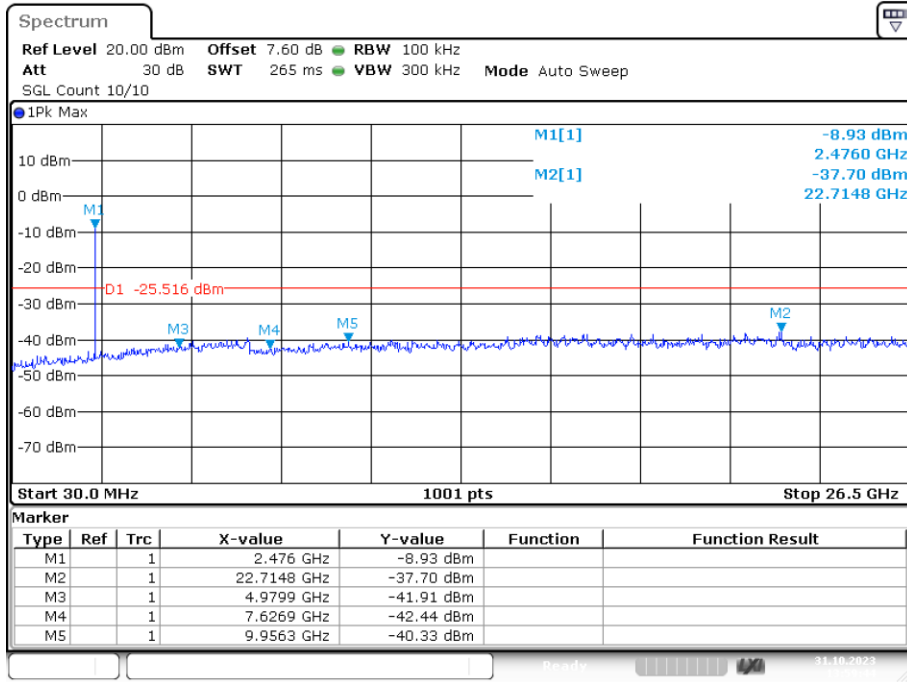

4. POWER LINE CONDUCTED EMISSION

4.1. Test Limits

| Frequency MHz | Limits dB(μ V) | |
|------------------|---------------------|---------------|
| | Quasi-peak Level | Average Level |
| 0.15 -0.50 | 66 -56* | 56 - 46* |
| 0.50 -5.00 | 56 | 46 |
| 5.00 -30.00 | 60 | 50 |

Notes: 1. *Decreasing linearly with logarithm of frequency.

2. The lower limit shall apply at the transition frequencies.

3. The limit decreases in line with the logarithm of the frequency in rang of 0.15 to 0.50 MHz.

4.2. Test Procedure

The EUT is put on the plane 0.8m high above the ground by insulating support and is connected to the power mains through a line impedance stabilization network (L.I.S.N.). This provides a 50ohm coupling impedance for the EUT system. Please refer the block diagram of the test setup and photographs. Both sides of AC lines are checked to find out the maximum conducted emission. In order to find the maximum emission levels, the relative positions of equipment and all of the interface cables shall be changed according to ANSI C63.10:2013 on Conducted Emission Measurement.

The bandwidth of test receiver is set at 9 kHz.

4.3. Test Setup

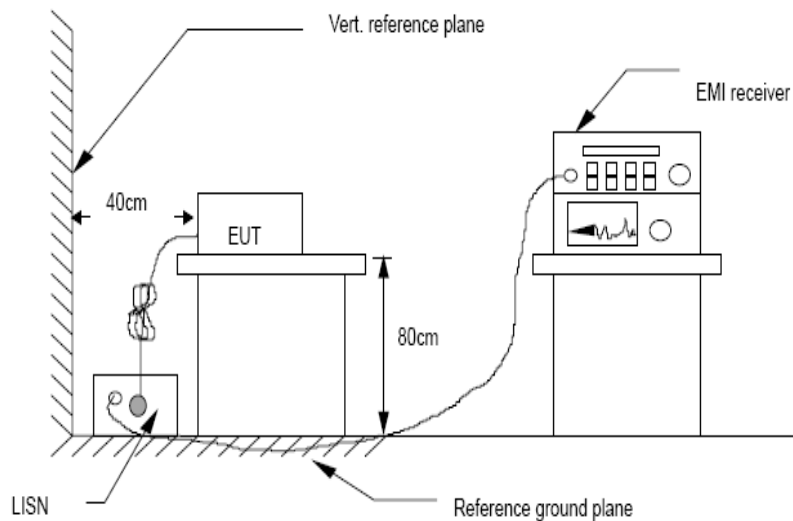

4.4. Test Results

Pass

Polarity: L

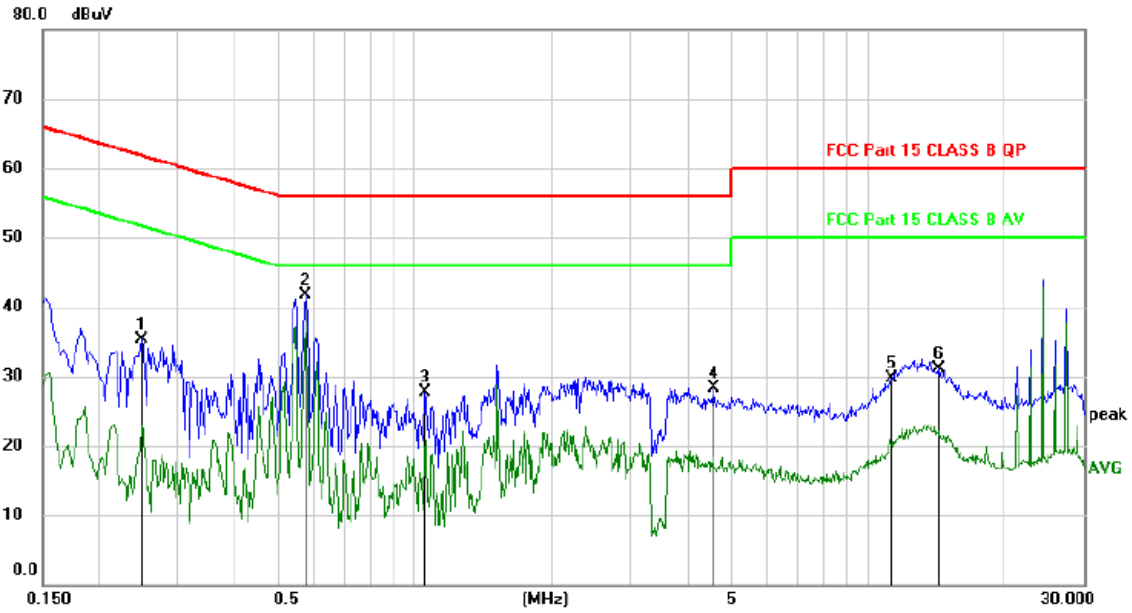

| No. | Mk. | Freq. MHz | Reading Level dBuV | Correct Factor dB | Measure- ment dBuV | Limit dBuV | Margin dB | Detector | Comment |
|-----|-----|--------------|--------------------------|-------------------------|--------------------------|---------------|--------------|----------|---------|
| 1 | | 0.2489 | 25.35 | 9.97 | 35.32 | 61.79 | -26.47 | peak | |
| 2 | * | 0.5726 | 31.75 | 9.93 | 41.68 | 56.00 | -14.32 | peak | |
| 3 | | 1.0526 | 17.84 | 9.91 | 27.75 | 56.00 | -28.25 | peak | |
| 4 | | 4.5720 | 18.35 | 10.01 | 28.36 | 56.00 | -27.64 | peak | |
| 5 | | 11.2590 | 19.37 | 10.24 | 29.61 | 60.00 | -30.39 | peak | |
| 6 | | 14.4237 | 20.86 | 10.32 | 31.18 | 60.00 | -28.82 | peak | |

*:Maximum data x:Over limit !:over margin

(Reference Only)

Note: Measurement=Reading Level+Correc Factor. Factor=(LISN or ISN or PLC or Current Probe)Factor+Cable

Polarity: N

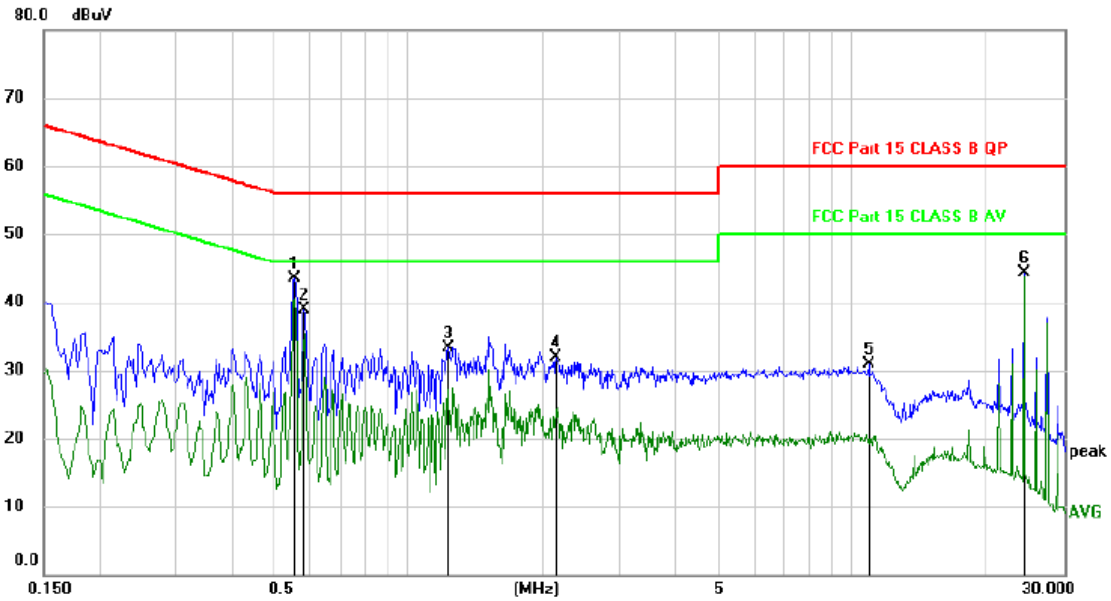

| No. | Mk. | Freq. MHz | Reading Level dBuV | Correct Factor dB | Measure- ment dBuV | Limit dBuV | Margin dB | Detector | Comment |
|-----|-----|--------------|--------------------------|-------------------------|--------------------------|---------------|--------------|----------|---------|
| 1 | * | 0.5550 | 33.50 | 9.94 | 43.44 | 56.00 | -12.56 | peak | |
| 2 | | 0.5818 | 28.88 | 9.93 | 38.81 | 56.00 | -17.19 | peak | |
| 3 | | 1.2300 | 23.48 | 9.89 | 33.37 | 56.00 | -22.63 | peak | |
| 4 | | 2.1509 | 22.01 | 9.88 | 31.89 | 56.00 | -24.11 | peak | |
| 5 | | 10.8719 | 20.62 | 10.23 | 30.85 | 60.00 | -29.15 | peak | |
| 6 | | 24.3870 | 33.86 | 10.44 | 44.30 | 60.00 | -15.70 | peak | |

*:Maximum data x:Over limit !:over margin

(Reference Only

Note: Measurement=Reading Level+Correc Factor. Factor=(LISN or ISN or PLC or Current Probe)Factor+Cable

Note: All modes and channels have been tested and only the GFSK 1M 2402MHz mode with the worst data is listed.

5. CONDUCTED MAXIMUM OUTPUT POWER

5.1. Test limits

Please refer section RSS-247 & 15.247.

5.2. Test Procedure

Details see the KDB 558074 D01 15.247 Meas Guidance v05r02

5.2.1 Place the EUT on the table and set it in transmitting mode.

5.2.2 Measure out each mode and each bands peak output power of EUT.

Note: The cable loss and attenuator loss were offset into measure device as amplitude offset.

5.3. Test Setup

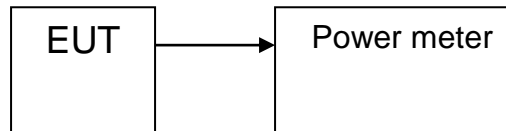

5.4. Test Results

| Condition | Mode | Frequency (MHz) | Antenna | Conducted Power (dBm) | Duty Factor (dB) | EIRP (dBm) | Limit (dBm) | Verdict |
|-----------|--------|-----------------|---------|-----------------------|------------------|------------|-------------|---------|
| NVNT | BLE 1M | 2402 | Ant1 | -6.186 | 0 | -4.436 | 30 | Pass |
| NVNT | BLE 1M | 2440 | Ant1 | -5.55 | 0 | -3.8 | 30 | Pass |
| NVNT | BLE 1M | 2480 | Ant1 | -6.339 | 0 | -4.589 | 30 | Pass |

| Condition | Mode | Frequency (MHz) | Antenna | Conducted Power (dBm) | Duty Factor (dB) | EIRP (dBm) | Limit (dBm) | Verdict |
|-----------|--------|-----------------|---------|-----------------------|------------------|------------|-------------|---------|
| NVNT | BLE 2M | 2402 | Ant1 | -6.197 | 0 | -4.447 | 30 | Pass |
| NVNT | BLE 2M | 2440 | Ant1 | -5.504 | 0 | -3.754 | 30 | Pass |
| NVNT | BLE 2M | 2480 | Ant1 | -6.341 | 0 | -4.591 | 30 | Pass |

6. PEAK POWER SPECTRAL DENSITY

6.1. Test limits

6.1.1 Please refer section RSS-247 & 15.247.

6.1.2 For direct sequence systems, the peak power spectral density conducted from the intentional radiator to the antenna shall not be greater than 8dBm in any 3kHz band during any time interval of continuous transmission.

6.1.3 The direct sequence operating of the hybrid system, with the frequency hopping operation turned off, shall comply with the power density requirements of paragraph (d) of this section.

6.2. Test Procedure

Details see the KDB 558074 D01 15.247 Meas Guidance v05r02

6.2.1 Place the EUT on the table and set it in transmitting mode.

6.2.2 Remove the antenna from the EUT and then connect a low loss RF cable from the antenna port to the spectrum analyzer.

6.2.3 Set the spectrum analyzer as $RBW = 3\text{kHz}$ (Set the RBW to: $3\text{ kHz} \leq RBW \leq 100\text{ kHz}$.), $VBW = 10\text{kHz}$ (Set the $VBW \geq 3 \times RBW$), $\text{span} = 1.5 \times \text{DTS bandwidth}$., detail see the test plot.

6.2.4 Record the max reading.

6.2.5 Repeat the above procedure until the measurements for all frequencies are completed.

6.3. Test Setup

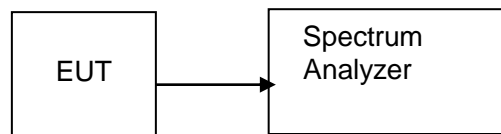

6.4. Test Results

Pass

The test results are listed in next pages.

| Condition | Mode | Frequency (MHz) | Antenna | Max PSD (dBm) | Limit (dBm) | Verdict |
|-----------|--------|-----------------|---------|---------------|-------------|---------|
| NVNT | BLE 1M | 2402 | Ant1 | -20.213 | 8 | Pass |
| NVNT | BLE 1M | 2440 | Ant1 | -19.535 | 8 | Pass |
| NVNT | BLE 1M | 2480 | Ant1 | -20.655 | 8 | Pass |

PSD NVNT BLE 1M 2402MHz Ant1

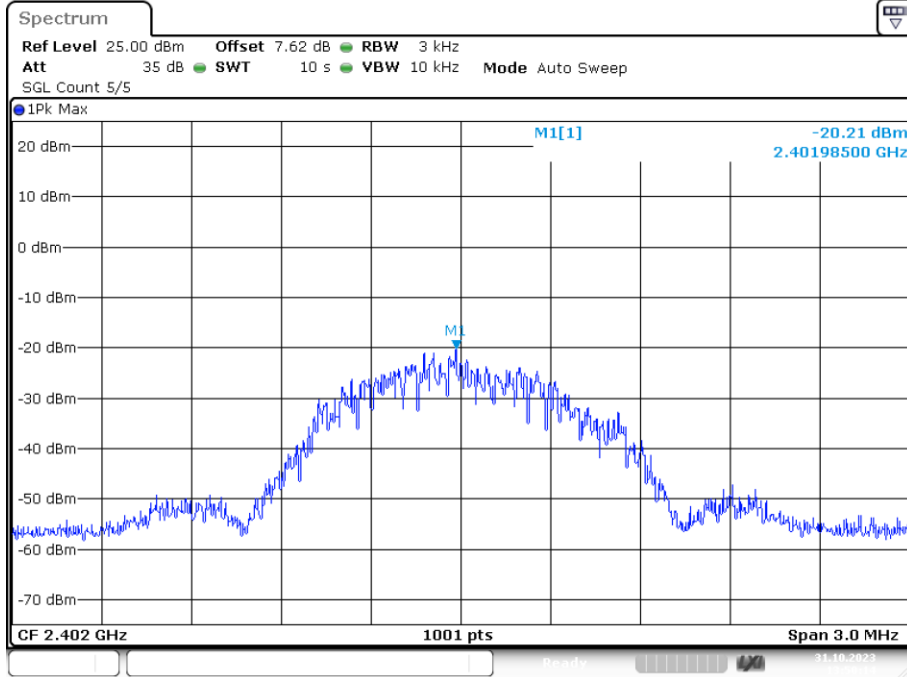

Date: 31.OCT.2023 13:50:14

PSD NVNT BLE 1M 2440MHz Ant1

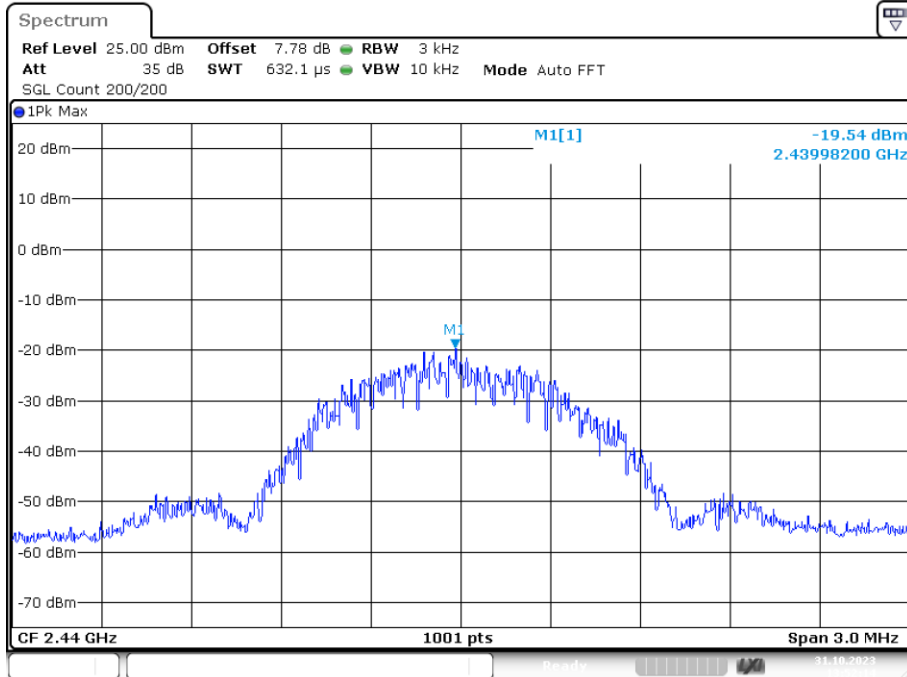

Date: 31.OCT.2023 13:52:14

PSD NVNT BLE 1M 2480MHz Ant1

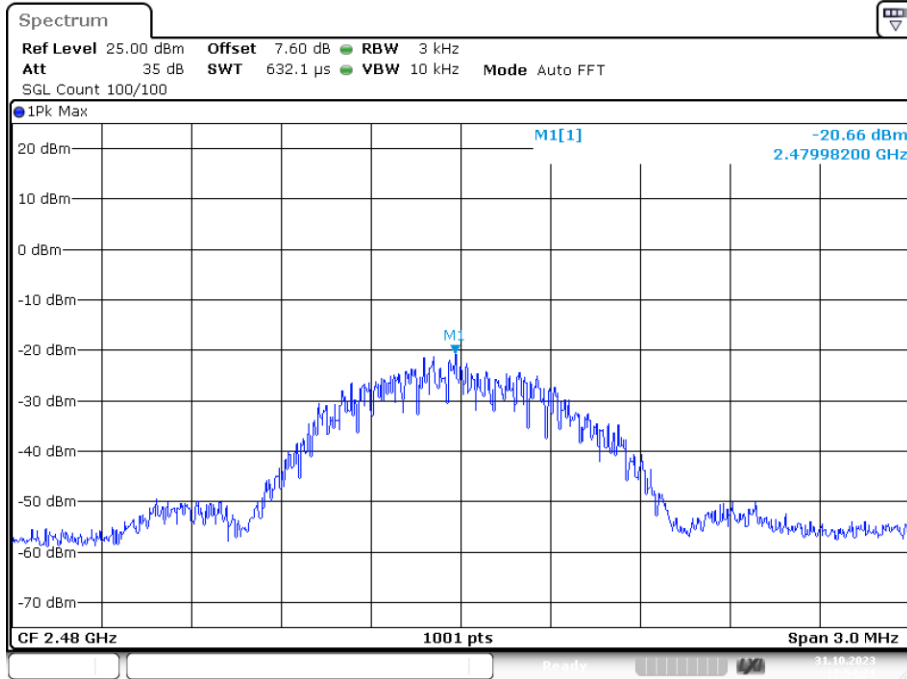

Date: 31.OCT.2023 13:54:21

| Condition | Mode | Frequency (MHz) | Antenna | Max PSD (dBm) | Limit (dBm) | Verdict |
|-----------|--------|-----------------|---------|---------------|-------------|---------|
| NVNT | BLE 2M | 2402 | Ant1 | -22.874 | 8 | Pass |
| NVNT | BLE 2M | 2440 | Ant1 | -21.978 | 8 | Pass |
| NVNT | BLE 2M | 2480 | Ant1 | -22.865 | 8 | Pass |

PSD NVNT BLE 2M 2402MHz Ant1

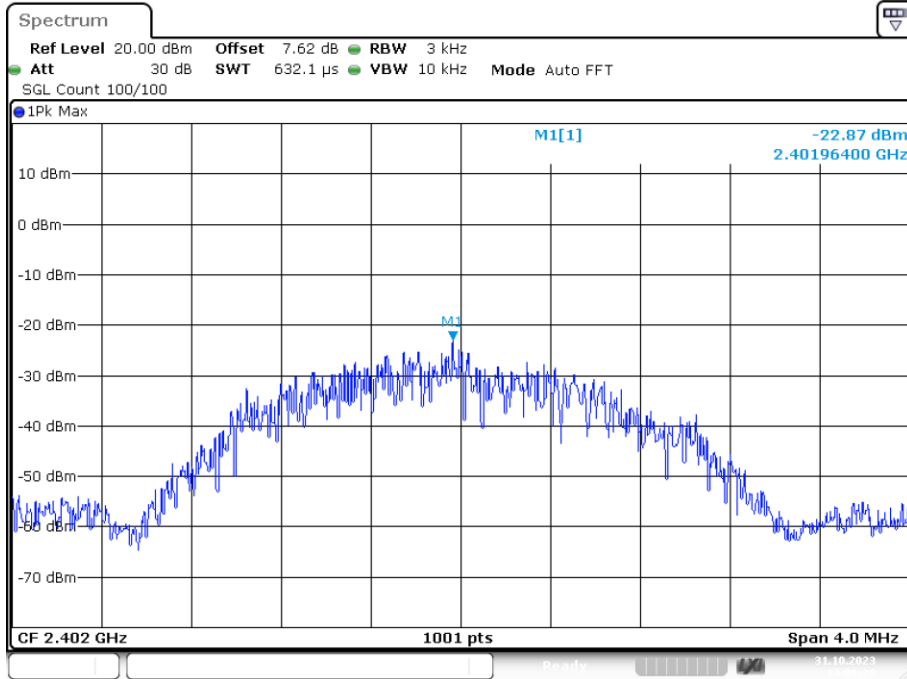

Date: 31.OCT.2023 14:08:27

PSD NVNT BLE 2M 2440MHz Ant1

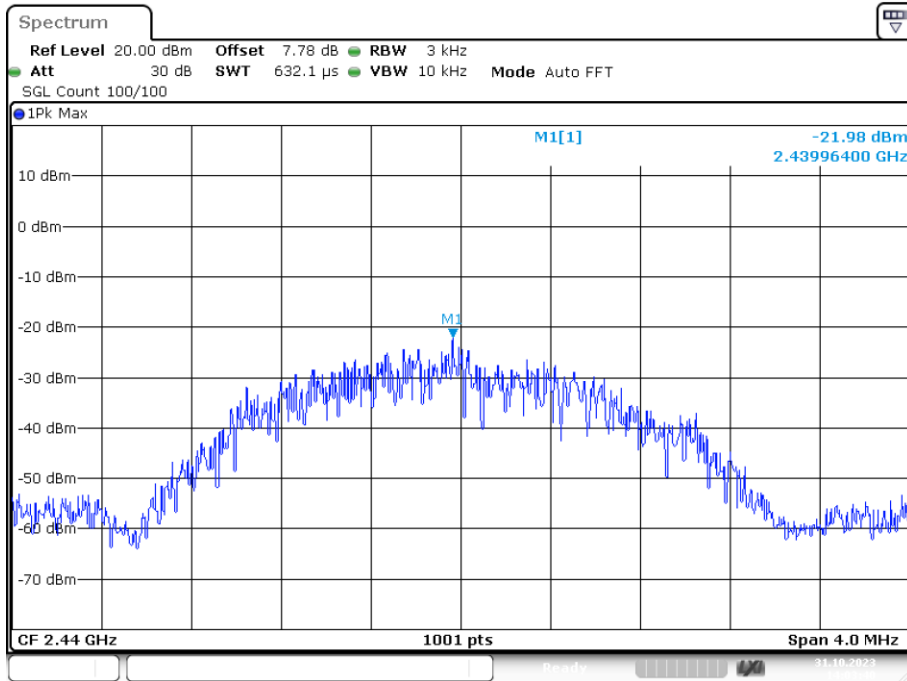

Date: 31.OCT.2023 14:03:40

PSD NVNT BLE 2M 2480MHz Ant1

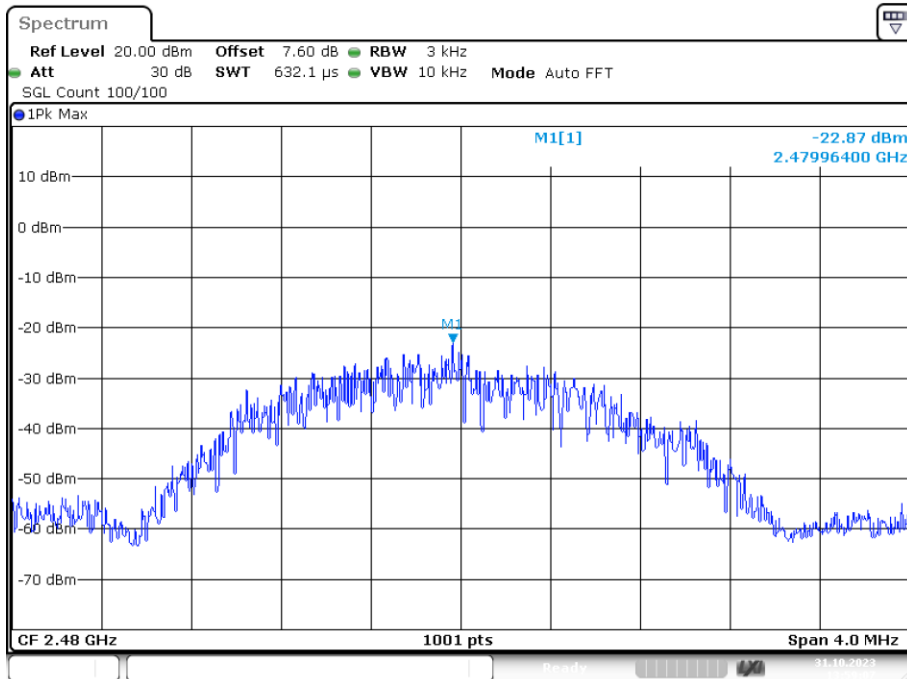

Date: 31.OCT.2023 13:59:08

7. BANDWIDTH

7.1. Test limits

Please refer section RSS-247 & 15.247

For direct sequence systems, the minimum 6dB bandwidth shall be at least 500 kHz.

7.2. Test Procedure

Details see the KDB 558074 D01 15.247 Meas Guidance v05r02

a) The bandwidth is measured at an amplitude level reduced 20dB from the reference level. The reference level is the level of the highest amplitude signal observed from the transmitter at the fundamental frequency. Once the reference level is established, the equipment is conditioned with typical modulating signal to produce the worst-case (i.e. the widest) bandwidth.

b) The test receiver set RBW = 100kHz, VBW \geq 3*RBW =300kHz, sweep time set auto, detail see the test plot.

7.3. Test Setup

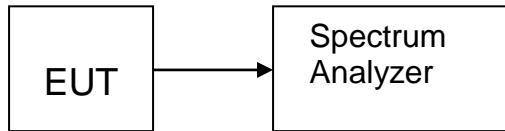

7.4. Test Results

-6dB Bandwidth

| Condition | Mode | Frequency (MHz) | Antenna | -6 dB Bandwidth (MHz) | Limit -6 dB Bandwidth (MHz) | Verdict |
|-----------|--------|-----------------|---------|-----------------------|-----------------------------|---------|
| NVNT | BLE 1M | 2402 | Ant1 | 0.703 | 0 | Pass |
| NVNT | BLE 1M | 2440 | Ant1 | 0.689 | 0 | Pass |
| NVNT | BLE 1M | 2480 | Ant1 | 0.686 | 0 | Pass |

-6dB Bandwidth NVNT BLE 1M 2402MHz Ant1

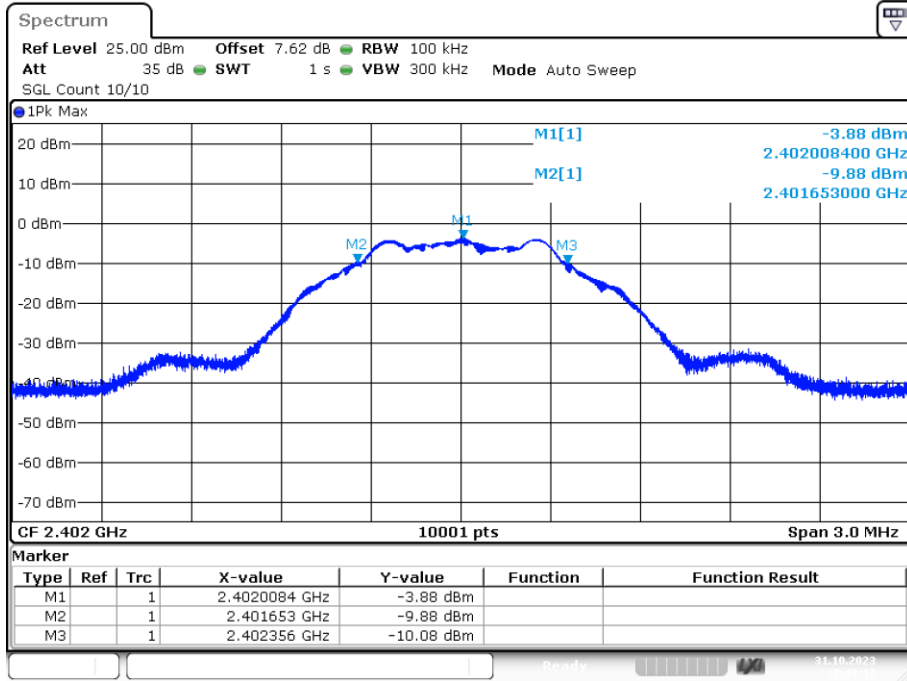

Date: 31.OCT.2023 13:49:17

-6dB Bandwidth NVNT BLE 1M 2440MHz Ant1

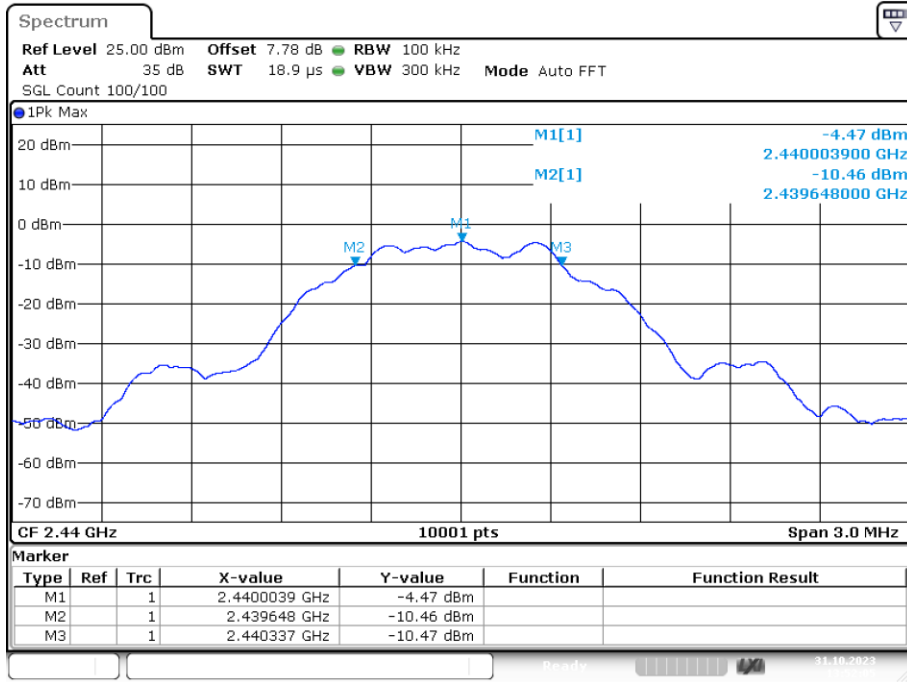

Date: 31.OCT.2023 13:52:05

-6dB Bandwidth NVNT BLE 1M 2480MHz Ant1

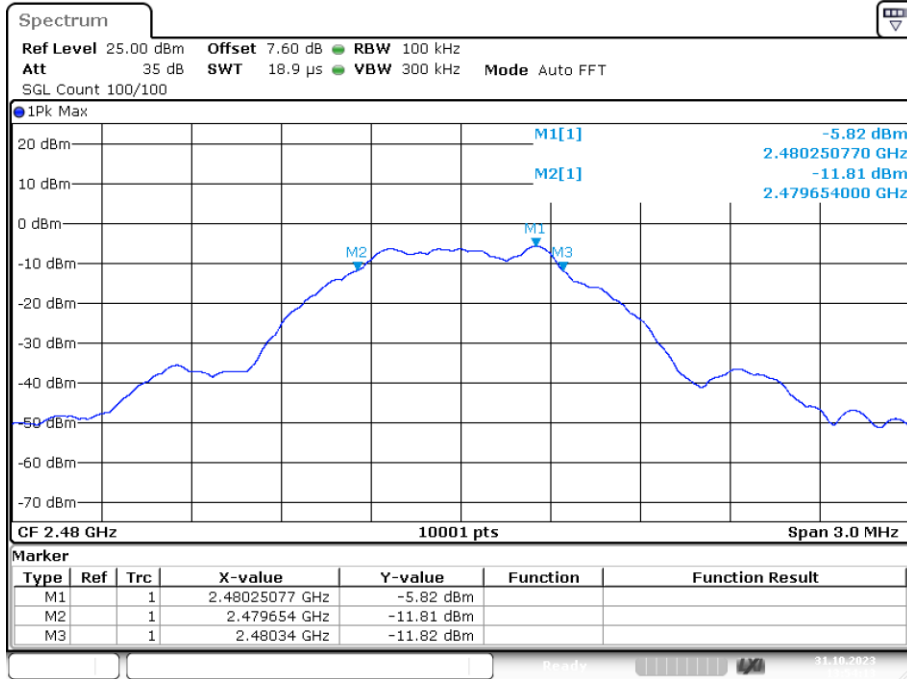

Date: 31.OCT.2023 13:54:12

Occupied Channel Bandwidth

| Condition | Mode | Frequency (MHz) | Antenna | 99% OBW (MHz) |
|-----------|--------|-----------------|---------|---------------|
| NVNT | BLE 1M | 2402 | Ant1 | 1.046 |
| NVNT | BLE 1M | 2440 | Ant1 | 1.031 |
| NVNT | BLE 1M | 2480 | Ant1 | 1.034 |

OBW NVNT BLE 1M 2402MHz Ant1

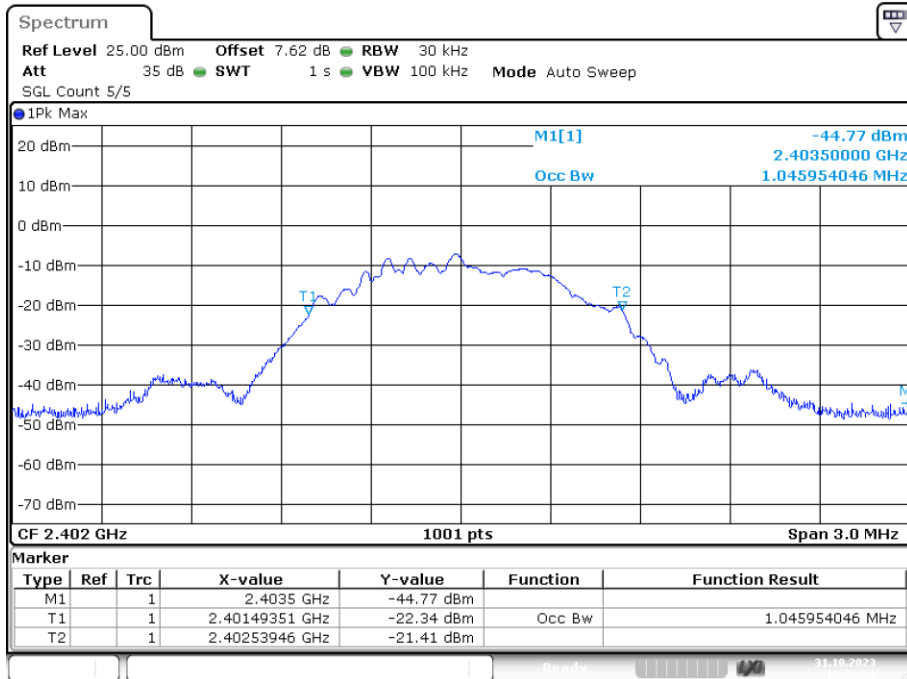

Date: 31.OCT.2023 13:48:59

OBW NVNT BLE 1M 2440MHz Ant1

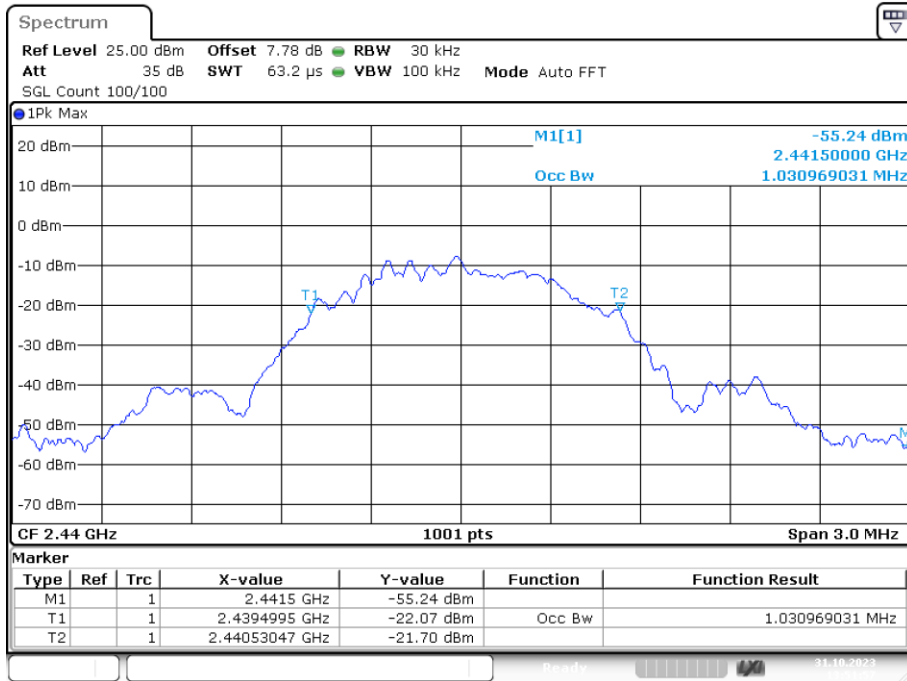

Date: 31.OCT.2023 13:51:57

OBW NVNT BLE 1M 2480MHz Ant1

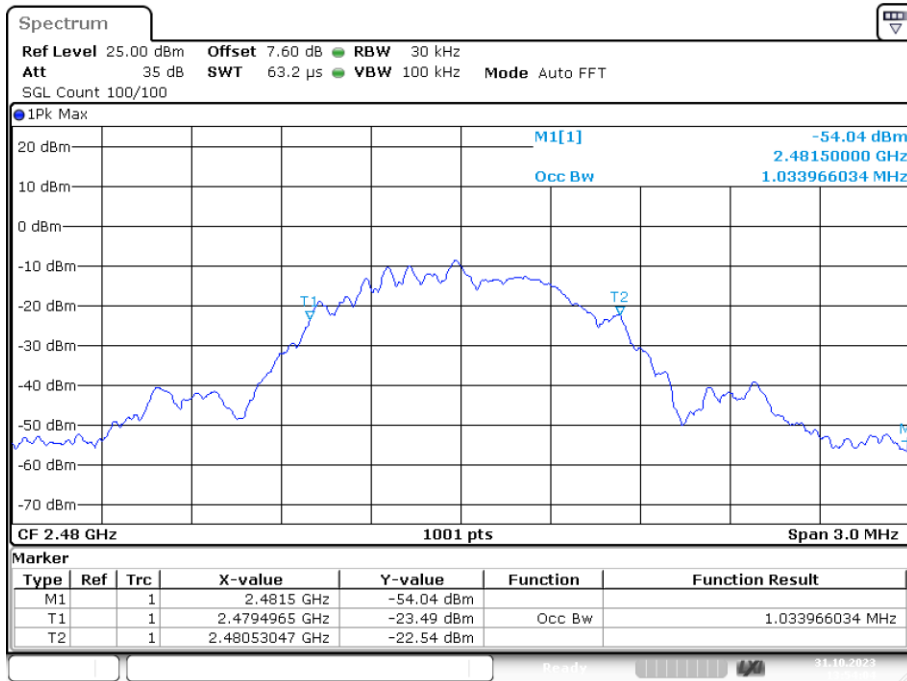

Date: 31.OCT.2023 13:54:03

-6dB Bandwidth

| Condition | Mode | Frequency (MHz) | Antenna | -6 dB Bandwidth (MHz) | Limit -6 dB Bandwidth (MHz) | Verdict |
|-----------|--------|-----------------|---------|-----------------------|-----------------------------|---------|
| NVNT | BLE 2M | 2402 | Ant1 | 1.266 | 0.5 | Pass |
| NVNT | BLE 2M | 2440 | Ant1 | 1.233 | 0.5 | Pass |
| NVNT | BLE 2M | 2480 | Ant1 | 0.891 | 0.5 | Pass |

-6dB Bandwidth NVNT BLE 2M 2402MHz Ant1

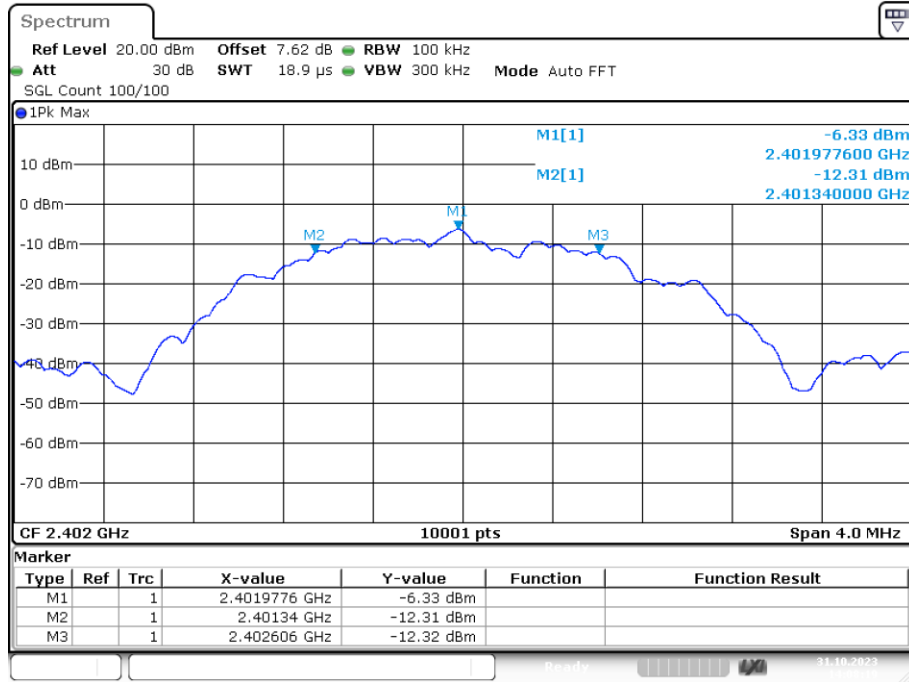

Date: 31.OCT.2023 14:08:19

-6dB Bandwidth NVNT BLE 2M 2440MHz Ant1

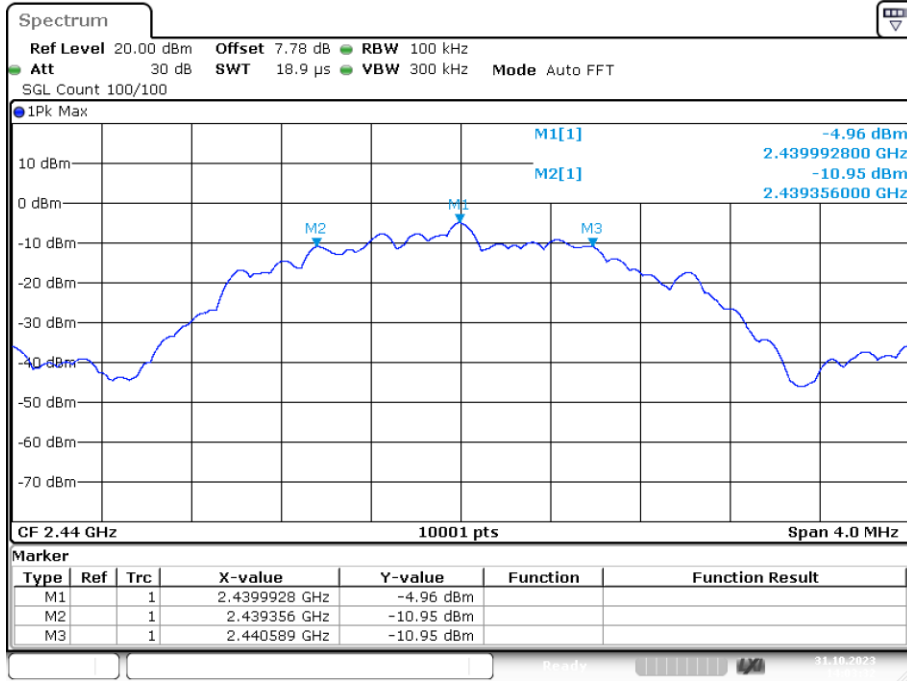

Date: 31.OCT.2023 14:03:32

-6dB Bandwidth NVNT BLE 2M 2480MHz Ant1

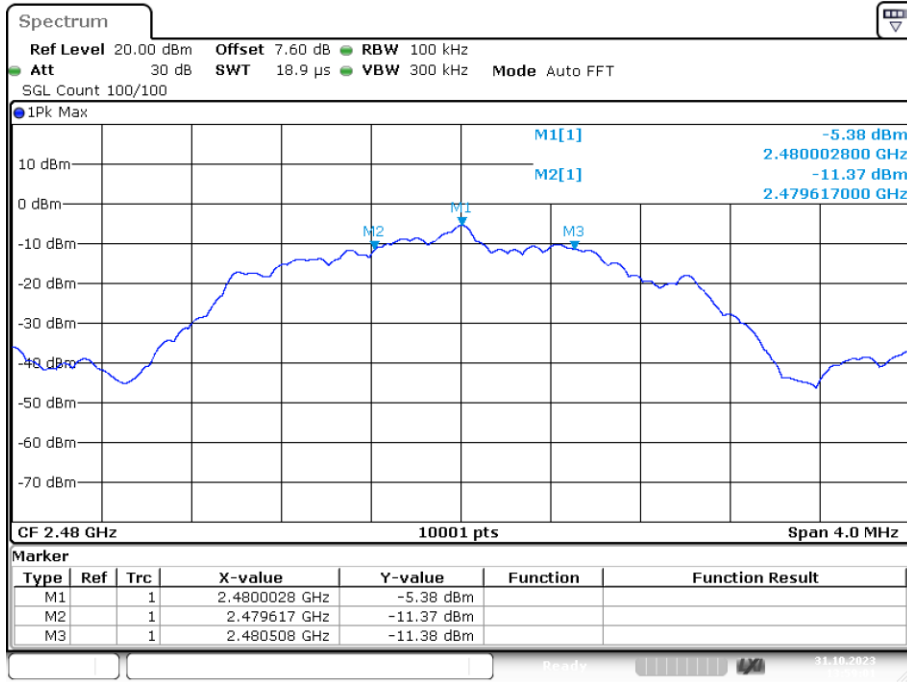

Date: 31.OCT.2023 13:59:01

Occupied Channel Bandwidth

| Condition | Mode | Frequency (MHz) | Antenna | 99% OBW (MHz) |
|-----------|--------|-----------------|---------|---------------|
| NVNT | BLE 2M | 2402 | Ant1 | 2.074 |
| NVNT | BLE 2M | 2440 | Ant1 | 2.066 |
| NVNT | BLE 2M | 2480 | Ant1 | 2.058 |

OBW NVNT BLE 2M 2402MHz Ant1

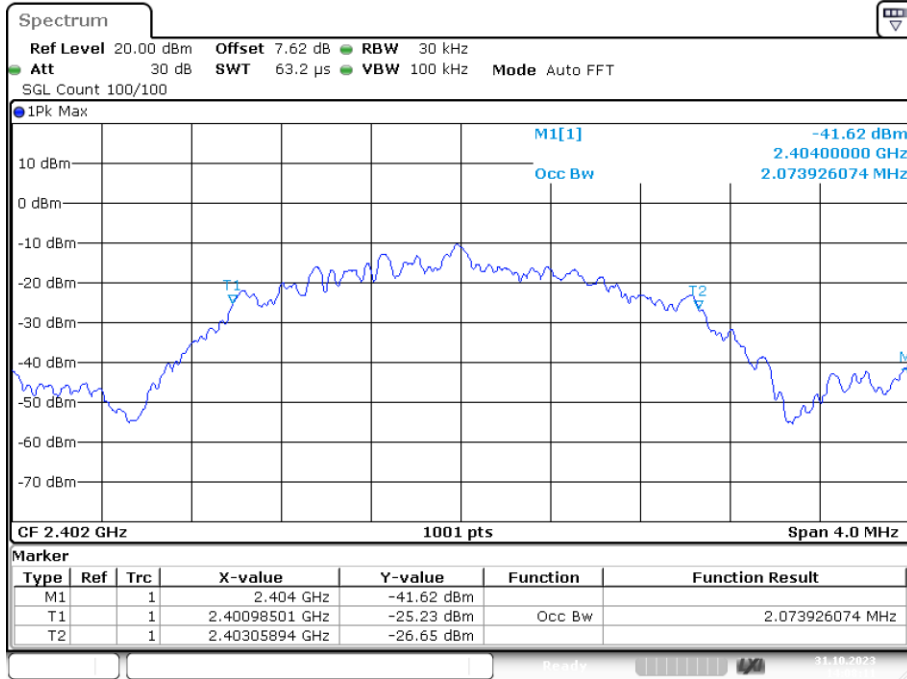

Date: 31.OCT.2023 14:08:10

OBW NVNT BLE 2M 2440MHz Ant1

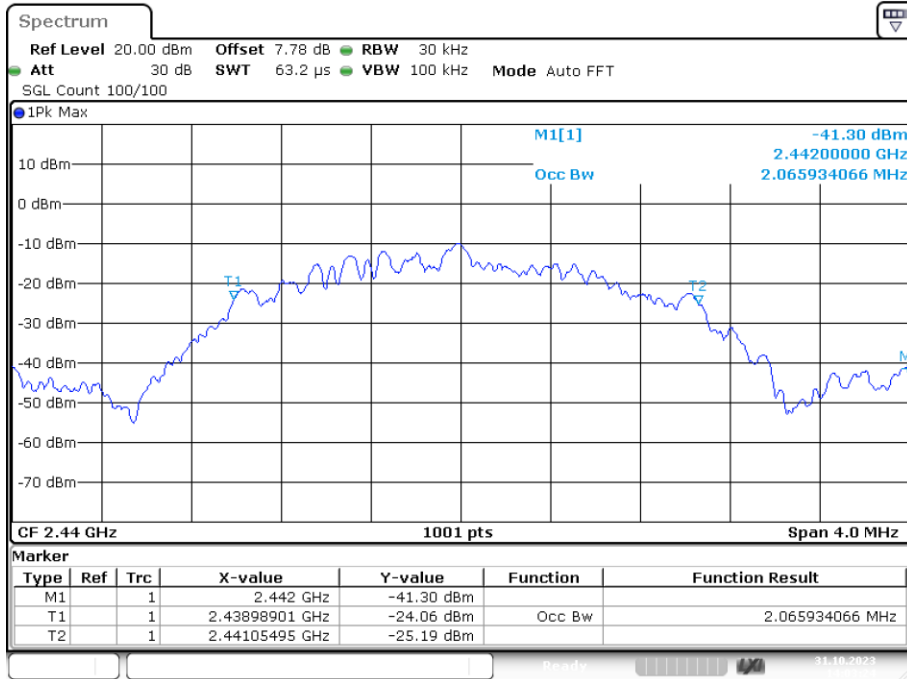

Date: 31.OCT.2023 14:03:24

OBW NVNT BLE 2M 2480MHz Ant1

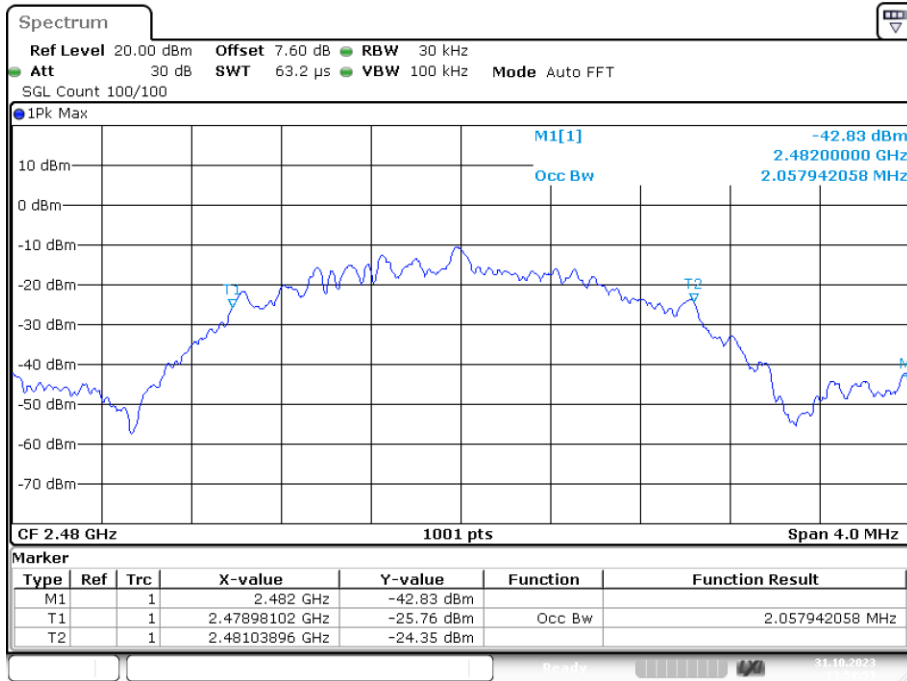

Date: 31.OCT.2023 13:58:53

8. BAND EDGE CHECK

8.1. Test limits

Please refer section RSS-GEN&15.247.

8.2. Test Procedure

Details see the KDB 558074 D01 15.247 Meas Guidance v05r02

8.2.1 Put the EUT on a 0.8m high table, power on the EUT. Emissions were scanned and measured rotating the EUT to 360 degrees, Find the maximum Emission

8.2.2 Check the spurious emissions out of band.

8.2.3 RBW 1MHz, VBW 3MHz, peak detector for peak value, RBW 1MHz, VBW 3MHz, RMS detector for AV value.

8.3. Test Setup

Same as 5.2.2.

8.4. Test Results

Pass

The test results are listed in next pages.

GFSK (1M)

Band Edge NVNT BLE 1M 2402MHz Ant1 Emission

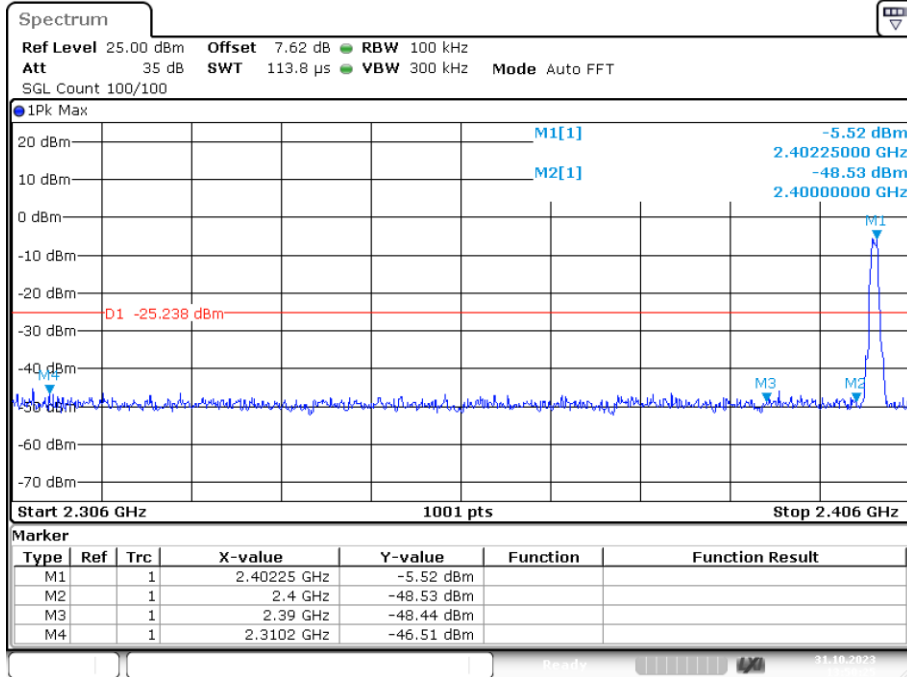

Date: 31.OCT.2023 13:50:25

Band Edge NVNT BLE 1M 2480MHz Ant1 Emission

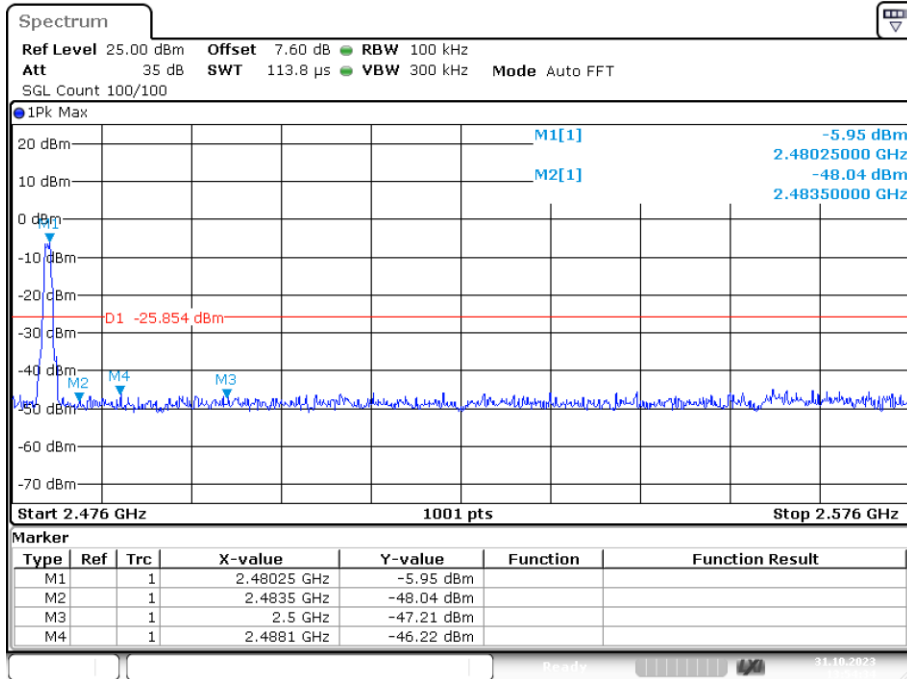

Date: 31.OCT.2023 13:54:33

Band Edge NVNT BLE 2M 2402MHz Ant1 Emission

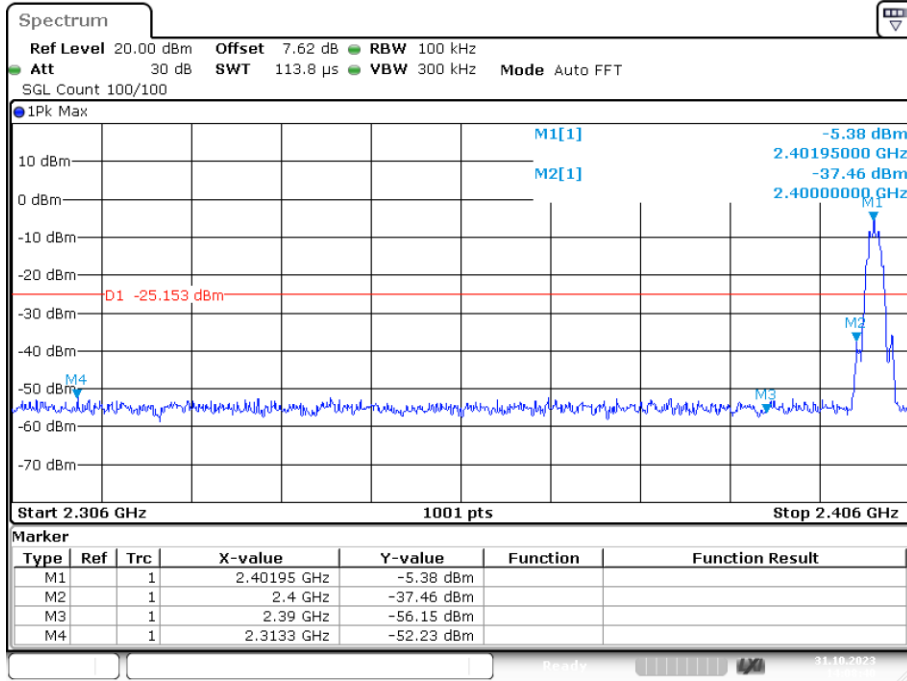

Date: 31.OCT.2023 14:08:40

Band Edge NVNT BLE 2M 2480MHz Ant1 Emission

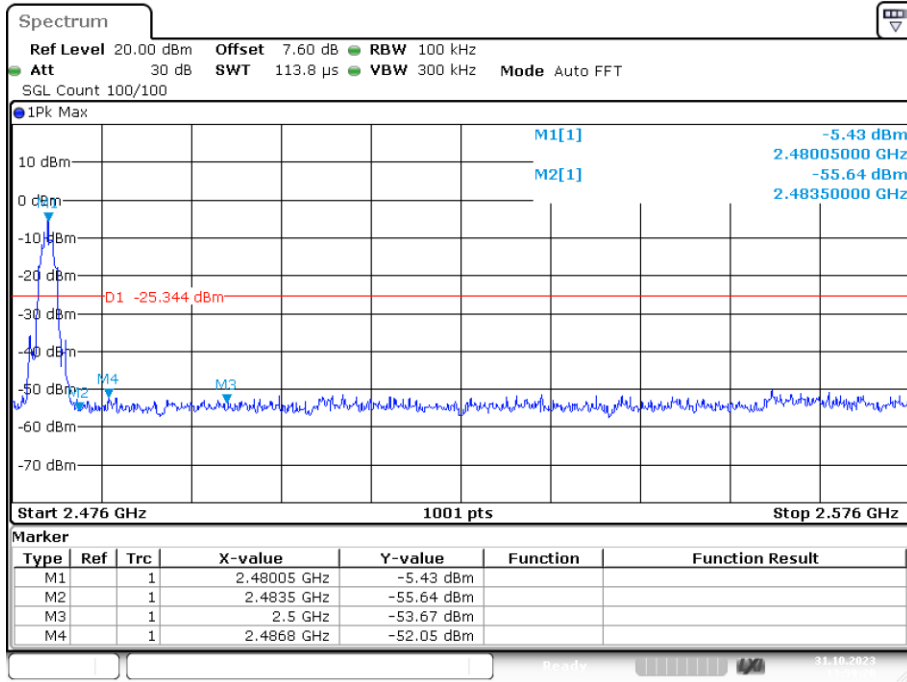

Date: 31.OCT.2023 13:59:19

Radiated Method: GFSK(1M)
Test Mode: CH-L

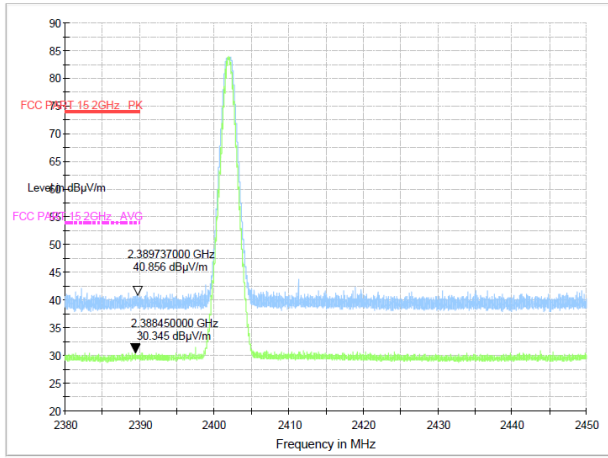

Test Mode: CH-H

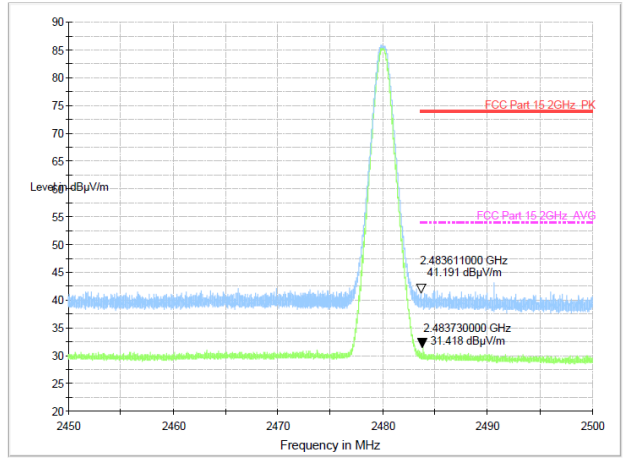

Radiated Method: GFSK(1M)
Test Mode: CH-H

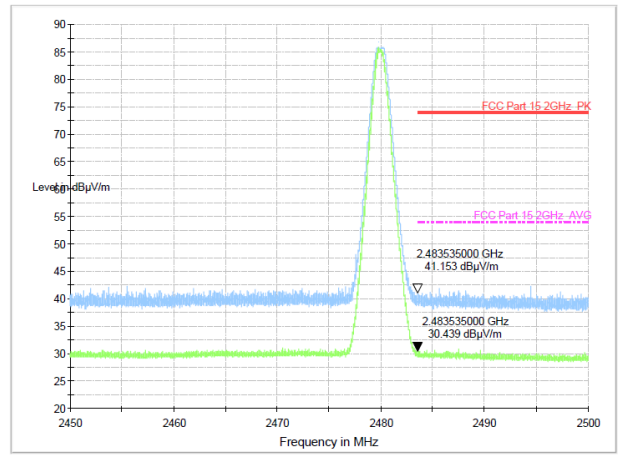
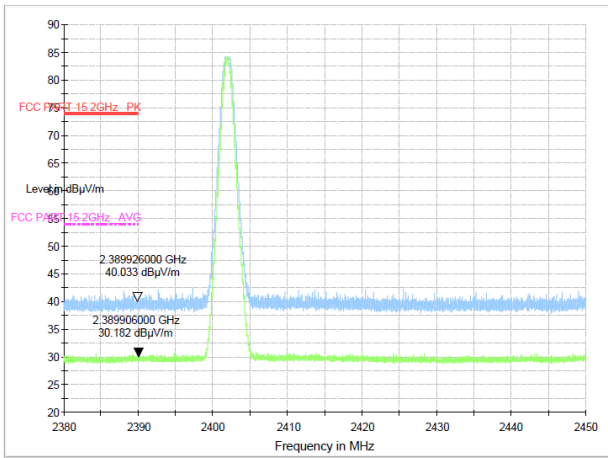

9. FREQUENCY STABILITY

9.1. Test limit

Please refer section RSS-Gen.

Regulation RSS-Gen If the frequency stability of the licence-exempt radio apparatus is not specified in the applicable RSS, the fundamental emissions of the radio apparatus should be kept within at least the central 80% of its permitted operating frequency band in order to minimize the possibility of out-of-band operation. In addition, its occupied bandwidth shall be entirely outside the restricted bands and the prohibited TV bands of 54-72 MHz, 76-88 MHz, 174-216 MHz, and 470-602 MHz, unless otherwise indicated.

9.2. Test Procedure

The following equipment are installed on the emission measurement to meet the commission requirements and operating regulations in a manner which tends to maximize its emission characteristics in normal application.

9.3. Test Setup

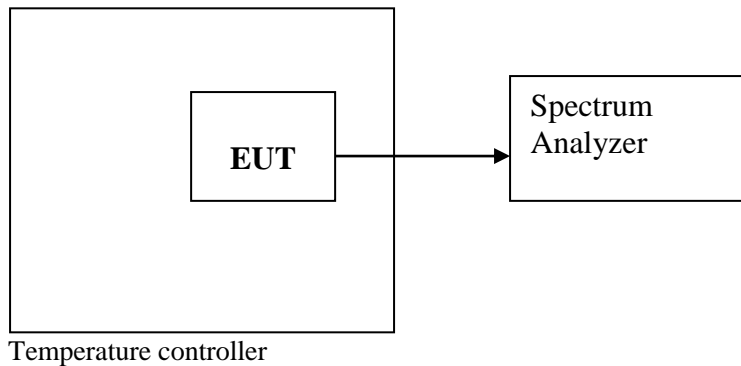

9.4. Test Results

PASS.

Detailed information please see the following page.

| Assigned Frequency(MHz): 2402MHz | | | | |
|----------------------------------|-------------|--------------------------|--------------------------|------------|
| Voltage | Temperature | Measured Frequency (MHz) | Frequency stability(MHz) | Limit(MHz) |
| Low DC 3.61V | +20°C | 2401.991 | -0.009 | ±0.020 |
| Normal DC 3.8V | -10°C | 2401.992 | -0.008 | ±0.020 |
| | -5°C | 2401.999 | -0.001 | ±0.020 |
| | 0°C | 2401.991 | -0.009 | ±0.020 |
| | +10°C | 2401.999 | -0.001 | ±0.020 |
| | +20°C | 2401.993 | -0.007 | ±0.020 |
| | +30°C | 2401.993 | -0.007 | ±0.020 |
| | +40°C | 2402.000 | 0.000 | ±0.020 |
| | +50°C | 2401.992 | -0.008 | ±0.020 |
| | +60°C | 2401.992 | -0.008 | ±0.020 |
| High DC 4.18V | +20°C | 2401.992 | -0.008 | ±0.020 |

10. ANTENNA REQUIREMENT

10.1. Standard Requirement

An intentional radiator shall be designed to ensure that no antenna other than that furnished by the responsible party shall be used with the device. The use of a permanently attached antenna or of an antenna that uses a unique coupling to the intentional radiator shall be considered sufficient to comply with the provisions of this Section. The manufacturer may design the unit so that a broken antenna can be replaced by the user, but the use of a standard antenna jack or electrical connector is prohibited.

10.2. Antenna Connected Construction

The antenna is internal antenna and no consideration of replacement. Please see EUT photo for details.

10.3. Results

The EUT antenna is Internal Antenna. It complies with the standard requirement.

11. TEST SETUP PHOTO

11.1. Photo of Radiated Emission test

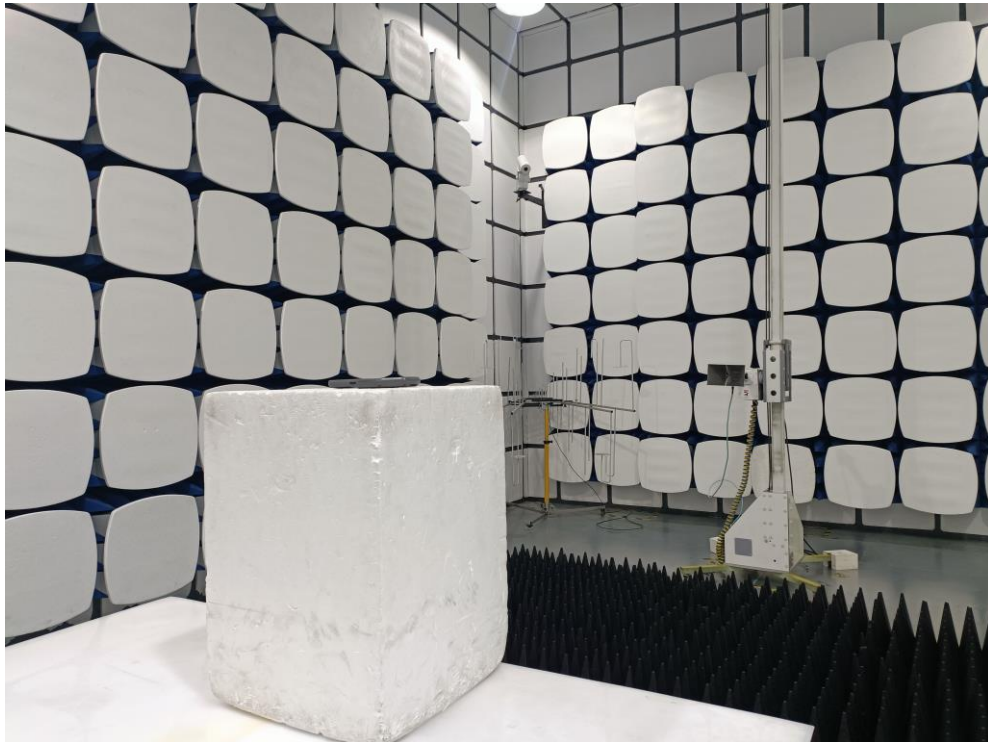
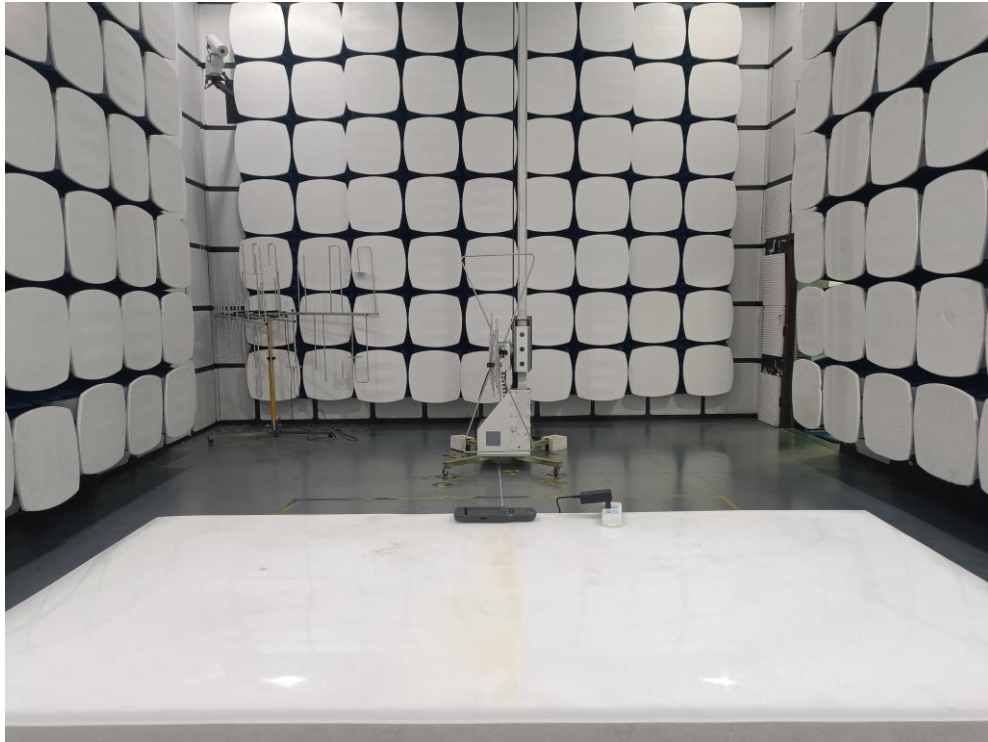

11.2.Photo of Conducted Emission test

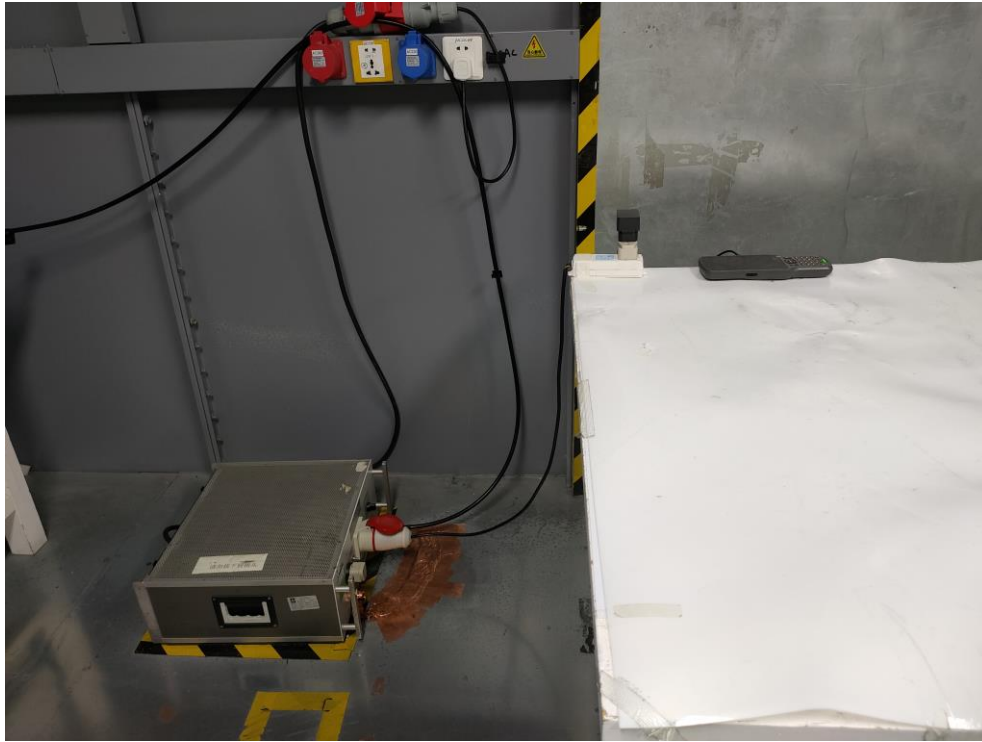

-----END OF REPORT-----