

FCC PART 15 SUBPART C TEST REPORT

FCC PART 15.247

Report Reference No..... : MTEB23090179-R2

FCC ID..... : 2BA3N-BIPCR2

Compiled by

(position+printed name+signature)..: File administrators Alisa Luo



Supervised by

(position+printed name+signature)..: Test Engineer Sunny Deng



Approved by

(position+printed name+signature)..: Manager Yvette Zhou



Date of issue.....: **Sep.19,2023**

Representative Laboratory Name.: Shenzhen Most Technology Service Co., Ltd.

Address.....: No.5, 2nd Langshan Road, North District, Hi-tech Industrial Park,
Nanshan, Shenzhen, Guangdong, China.

Applicant's name..... : Shandong New Beiyang Information Technology Co.,Ltd

Address.....: 169 HUOJU RD HI-TECH ZONE WEIHAI SHANDONG, Weihai,
264209, CHINA

Test specification..... :

Standard.....: **FCC Part 15.247**

TRF Originator.....: Shenzhen Most Technology Service Co., Ltd.

Shenzhen Most Technology Service Co., Ltd. All rights reserved.

This publication may be reproduced in whole or in part for non-commercial purposes as long as the Shenzhen Most Technology Service Co., Ltd. is acknowledged as copyright owner and source of the material. Shenzhen Most Technology Service Co., Ltd. takes no responsibility for and will not assume liability for damages resulting from the reader's interpretation of the reproduced material due to its placement and context.

Test item description..... : Fanless Embedded Android Computer

Trade Mark.....: SNBC

Model/Type reference.....: BIPC-R200

Listed Models: N/A

Modulation Type.....: b: DSSS ,CCK

g/n: BPSK,QPSK,QAM

Operation Frequency.....: From 2412MHz~2462MHz

Rating.....: DC 12V

Hardware version.....: V1.2

Software version: snbcbox-android_arm-release-7.1.2-snbc-20230524.134909

Result.....: **PASS**

TEST REPORT

Equipment under Test : Fanless Embedded Android Computer

Model /Type : BIPC-R200

Listed Models : N/A

Remark : N/A.

Applicant : Shandong New Beiyang Information Technology Co.,Ltd

Address : 169 HUOJU RD HI-TECH ZONE WEIHAI SHANDONG, Weihai,
264209, CHINA

Manufacturer : Shandong New Beiyang Information Technology Co.,Ltd

Address : 169 HUOJU RD HI-TECH ZONE WEIHAI SHANDONG, Weihai,
264209, CHINA

Test Result:	PASS
---------------------	-------------

The test report merely corresponds to the test sample.
It is not permitted to copy extracts of these test result without the written permission of the test laboratory.

Contents

1	REVISION HISTORY	4
2	TEST STANDARDS	5
3	SUMMARY	6
3.1	General Remarks	6
3.2	Product Description	6
3.3	Equipment Under Test	6
3.4	Short description of the Equipment under Test (EUT)	6
3.5	EUT operation mode	6
3.6	Block Diagram of Test Setup	7
3.7	Test Item (Equipment Under Test) Description*	7
3.8	Auxiliary Equipment (AE) Description	7
3.9	Antenna Information*	7
3.10	Related Submittal(s) / Grant (s)	7
3.11	Modifications	8
3.12	EUT configuration	8
4	TEST ENVIRONMENT	9
4.1	Address of the test laboratory	9
4.2	Test Facility	9
4.3	Environmental conditions	9
4.4	Test Description	10
4.5	Statement of the measurement uncertainty	10
4.6	Equipments Used during the Test	11
5	TEST CONDITIONS AND RESULTS	12
5.1	AC Power Conducted Emission	12
5.2	Radiated Emission	15
5.3	Maximum Conducted Output Power	22
5.4	Power Spectral Density	23
5.5	6dB Bandwidth	24
5.6	Out-of-band Emissions	25
5.7	Duty Cycle Information	26
5.8	Antenna Requirement	27
6	TEST SETUP PHOTOS OF THE EUT	28
7	PHOTOS OF THE EUT	29
	APPENDIX I. Conducted Peak Output Power	30
	APPENDIX II. 99% Bandwidth	31
	APPENDIX III. 6dB Bandwidth	33
	APPENDIX IV. Conducted Out Of Band Emission	35
	APPENDIX V. Duty Cycle	41
	APPENDIX VI. Power Spectral Density	46

1 Revision History

Revision	Issue Date	Revisions	Revised By
00	2023-09-19	Initial Issue	Alisa Luo

2 TEST STANDARDS

The tests were performed according to following standards:

[FCC Rules Part 15.247](#): Frequency Hopping, Direct Spread Spectrum and Hybrid Systems that are in operation within the bands of 902-928 MHz, 2400-2483.5 MHz, and 5725-5850 MHz.

[ANSI C63.10-2013](#): American National Standard for Testing Unlicensed Wireless Devices

[KDB558074 D01 v05r02](#): Guidance for Compliance Measurements on Digital Transmission Systems (DTS) ,Frequency Hopping Spread Spectrum System(HFSS), and Hybrid System Devices Operating Under §15.247 of The FCC rules.

3 SUMMARY

3.1 General Remarks

Date of receipt of test sample	:	2023.09.13
Testing commenced on	:	2023.09.14-18
Testing concluded on	:	2023.09.19

3.2 Product Description

Product Name:	Fanless Embedded Android Computer
Model/Type reference:	BIPC-R200
Power Supply:	DC 12V
Testing sample ID:	MTYP02939
WIFI :	
Supported type:	802.11b/802.11g/802.11n(H20)
Modulation:	b: DSSS ,CCK g/n: BPSK,QPSK,QAM
Operation frequency:	802.11b/802.11g/802.11n(H20): 2412MHz~2462MHz
Channel number:	802.11b/802.11g/802.11n(H20): 11
Channel separation:	5MHz
Antenna type:	Sucker Antenna
Antenna gain:	1.91dBi

3.3 Equipment Under Test

Power supply system utilised

Power supply voltage	:	<input type="radio"/> 230V / 50 Hz	<input type="radio"/> 120V / 60Hz
		<input type="radio"/> 12 V DC	<input type="radio"/> 24 V DC
		<input checked="" type="radio"/> Other (specified in blank below)	

DC 12V

3.4 Short description of the Equipment under Test (EUT)

This is a Fanless Embedded Android Computer For more details, refer to the user's manual of the EUT.

3.5 EUT operation mode

The application provider specific test software(AT command) to control sample in continuous TX and RX (Duty Cycle >98%) for testing meet KDB558074 test requirement.

IEEE 802.11b/g/n: Thirteen channels are provided to the EUT.

Channel	Frequency(MHz)	Channel	Frequency(MHz)
1	2412	8	2447
2	2417	9	2452
3	2422	10	2457
4	2427	11	2462
5	2432		
6	2437		
7	2442		

3.6 Block Diagram of Test Setup

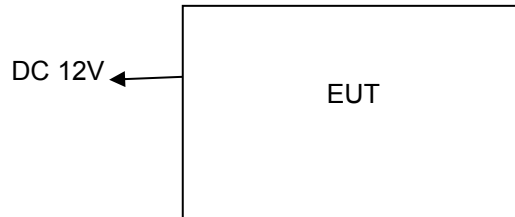

3.7 Test Item (Equipment Under Test) Description*

Short designation	EUT Name	EUT Description	Serial number	Hardware status	Software status
EUT A	/	/	/	/	/
EUT B	/	/	/	/	/

*: declared by the applicant. According to customers information EUTs A and B are the same devices.

3.8 Auxiliary Equipment (AE) Description

AE short designation	EUT Name (if available)	EUT Description	Serial number (if available)	Software (if used)
AE 1	Adapter	FJ-SW1202000C	/	/
AE 2	/	/	/	/

3.9 Antenna Information*

Short designation	Antenna Name	Antenna Type	Frequency Range	Serial number	Antenna Peak Gain
Antenna 1	---	Sucker Antenna	2.4 – 2.5 GHz	---	1.91dBi
Antenna 2					

*: declared by the applicant.

3.10 Related Submittal(s) / Grant (s)

This submittal(s) (test report) is intended for **FCC ID: 2BA3N-BIPCR2** filing to comply with Section 15.247 of the FCC Part 15, Subpart C Rules.

3.11 Modifications

No modifications were implemented to meet testing criteria.

3.12 EUT configuration

The following peripheral devices and interface cables were connected during the measurement:

- supplied by the manufacturer

- Supplied by the lab

<input checked="" type="radio"/>	ADAPTER	M/N:	FJ-SW1202000C
<input type="radio"/>		Manufacturer:	Shenzhen Fujia Appliance Co., Ltd.

4 TEST ENVIRONMENT

4.1 Address of the test laboratory

Shenzhen Most Technology Service Co., Ltd.

No.5, 2nd Langshan Road, North District, Hi-tech Industrial Park, Nanshan, Shenzhen, Guangdong, China.
The 3m-Semi anechoic test site fulfils CISPR 16-1-4 according to ANSI C63.4:2014 and CISPR 16-1-4:2010 SVSWR requirement for radiated emission above 1GHz.

4.2 Test Facility

The test facility is recognized, certified, or accredited by the following organizations:

FCC-Registration No.: 0031192610

Shenzhen Most Technology Service Co., Ltd. EMC Laboratory has been registered and fully described in a report filed with the (FCC) Federal Communications Commission. The acceptance letter from the FCC is maintained in our files.

A2LA-Lab Cert. No.: 6343.01

Shenzhen Most Technology Service Co., Ltd. EMC Laboratory has been accredited by A2LA for technical competence in the field of electrical testing, and proved to be in compliance with ISO/IEC 17025: 2005 General Requirements for the Competence of Testing and Calibration Laboratories and any additional program requirements in the identified field of testing.

4.3 Environmental conditions

Radiated Emission:

Temperature:	24 ° C
Humidity:	48 %
Atmospheric pressure:	950-1050mbar

AC Main Conducted testing:

Temperature:	24 ° C
Humidity:	45 %
Atmospheric pressure:	950-1050mbar

Conducted testing:

Temperature:	24 ° C
Humidity:	45 %
Atmospheric pressure:	950-1050mbar

4.4 Test Description

FCC PART 15.247		
FCC Part 15.207	AC Power Conducted Emission	N/A
FCC Part 15.247(a)(2)	6dB Bandwidth	PASS
FCC Part 15.247(d)	Spurious RF Conducted Emission	PASS
FCC Part 15.247(b)	Maximum Conducted Output Power	PASS
FCC Part 15.247(e)	Power Spectral Density	PASS
FCC Part 15.109/ 15.205/ 15.209	Radiated Emissions	PASS
FCC Part 15.247(d)	Band Edge	PASS
FCC Part 15.203/15.247 (b)	Antenna Requirement	PASS

Data Rate Used:

Preliminary tests were performed in different data rate to find the worst radiated emission. The data rate shown in the table below is the worst-case rate with respect to the specific test item. Investigation has been done on all the possible configurations for searching the worst cases. The following table is a list of the test modes shown in this test report.

Test Items	Mode	Data Rate	Channel
Maximum Peak Conducted Output Power Power Spectral Density 6dB Bandwidth Spurious RF conducted emission Radiated Emission 9KHz~1GHz& Radiated Emission 1GHz~10 th Harmonic	11b/DSSS	1 Mbps	1/6/11
	11g/OFDM	6 Mbps	1/6/11
	11n(20MHz)/OFDM	6.5Mbps	1/6/11
	11n(40MHz)/OFDM	6.5Mbps	3/6/9
Band Edge	11b/DSSS	1 Mbps	1/11
	11g/OFDM	6 Mbps	1/11
	11n(20MHz)/OFDM	6.5Mbps	1/11
	11n(40MHz)/OFDM	6.5Mbps	3/9

4.5 Statement of the measurement uncertainty

The data and results referenced in this document are true and accurate. The reader is cautioned that there may be errors within the calibration limits of the equipment and facilities. The measurement uncertainty was calculated for all measurements listed in this test report acc. to CISPR 16 - 4 „Specification for radio disturbance and immunity measuring apparatus and methods – Part 4: Uncertainty in EMC Measurements“ and is documented in the Shenzhen Most Technology Service Co., Ltd. quality system acc. to DIN EN ISO/IEC 17025. Furthermore, component and process variability of devices similar to that tested may result in additional deviation. The manufacturer has the sole responsibility of continued compliance of the device.

Hereafter the best measurement capability for Shenzhen Most Technology Service Co., Ltd. is reported:

Test	Range	Measurement Uncertainty	Notes
Radiated Emission	30~1000MHz	4.10 dB	(1)
Radiated Emission	1~18GHz	4.32 dB	(1)
Radiated Emission	18-40GHz	5.54 dB	(1)
Conducted Disturbance	0.15~30MHz	3.12 dB	(1)
6dB Bandwidth & 99% Bandwidth	/	5%	(1)
Maximum Conducted Output Power	/	0.80dB	(1)
Spurious RF Conducted Emission	/	1.6dB	(1)

(1) This uncertainty represents an expanded uncertainty expressed at approximately the 95% confidence level using a coverage factor of k=2.

4.6 Equipments Used during the Test

Item	Equipment	Manufacturer	Model No.	Serial No.	Firmware versions	Last Cal.	Cal. Interval
1.	L.I.S.N.	R&S	ENV216	100093	/	2023/03/17	1 Year
2	Three-phase artificial power network	Schwarzback Mess	NNLK8129	8129178	/	2023/03/17	1 Year
3.	Receiver	R&S	ESCI	100492	V3.0-10-2	2023/03/17	1 Year
4	Receiver	R&S	ESPI	101202	V3.0-10-2	2023/03/17	1 Year
5	Spectrum analyzer	Agilent	9020A	MT-E306	A14.16	2023/03/17	1 Year
6	Bilong Antenna	Sunol Sciences	JB3	A121206	/	2023/03/17	1 Year
7	Horn antenna	HF Antenna	HF Antenna	MT-E158	/	2023/03/17	1 Year
8	Loop antenna	Beijing Daze	ZN30900B	/	/	2023/03/17	1 Year
9	Horn antenna	R&S	OBH100400	26999002	/	2023/03/17	1 Year
10	Wireless Communication Test Set	R&S	CMW500	/	CMW-BASE-3.7.21	2023/03/17	1 Year
11	Spectrum analyzer	R&S	FSP	100019	V4.40 SP2	2023/03/17	1 Year
12	High gain antenna	Schwarzbeck	LB-180400KF	MT-E389	/	2023/03/17	1 Year
13	Preamplifier	Schwarzbeck	BBV 9743	MT-E390	/	2023/03/17	1 Year
14	Pre-amplifier	EMCI	EMC051845S E	MT-E391	/	2023/03/17	1 Year
15	Pre-amplifier	Agilent	83051A	MT-E392	/	2023/03/17	1 Year
16	High pass filter unit	Tonscend	JS0806-F	MT-E393	/	2023/03/17	1 Year
17	RF Cable(below1GHz)	Times	9kHz-1GHz	MT-E394	/	2023/03/17	1 Year
18	RF Cable(above 1GHz)	Times	1-40G	MT-E395	/	2023/03/17	1 Year
19	RF Cable (9KHz-40GHz)	Tonscend	170660	N/A	/	2023/03/17	1 Year
20	Power meter	R&S	NRVS	100444	/	2023/03/17	1 Year

Note: The Cal.Interval was one year.

5 TEST CONDITIONS AND RESULTS

5.1 AC Power Conducted Emission

TEST CONFIGURATION

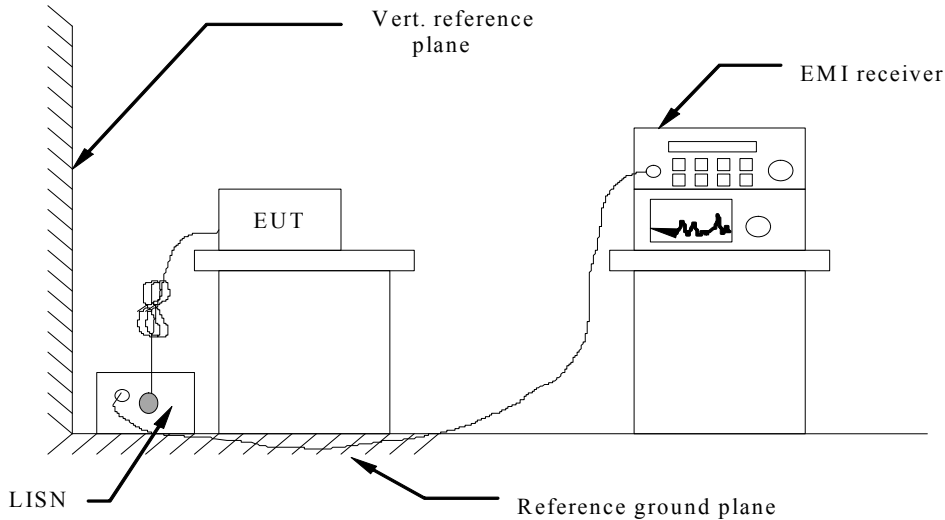

TEST PROCEDURE

- 1 The equipment was set up as per the test configuration to simulate typical actual usage per the user's manual. The EUT is a tabletop system, a wooden table with a height of 0.8 meters is used and is placed on the ground plane as per ANSI C63.10-2013.
- 2 Support equipment, if needed, was placed as per ANSI C63.10-2013
- 3 All I/O cables were positioned to simulate typical actual usage as per ANSI C63.10-2013
- 4 The EUT received DC 12V power from adapter, the adapter received AC120V/60Hz and AC 240V/60Hz power through a Line Impedance Stabilization Network (LISN) which supplied power source and was grounded to the ground plane.
- 5 All support equipments received AC power from a second LISN, if any.
- 6 The EUT test program was started. Emissions were measured on each current carrying line of the EUT using a spectrum Analyzer / Receiver connected to the LISN powering the EUT. The LISN has two monitoring points: Line 1 (Hot Side) and Line 2 (Neutral Side). Two scans were taken: one with Line 1 connected to Analyzer / Receiver and Line 2 connected to a 50 ohm load; the second scan had Line 1 connected to a 50 ohm load and Line 2 connected to the Analyzer / Receiver.
- 7 Analyzer / Receiver scanned from 150 KHz to 30MHz for emissions in each of the test modes.
- 8 During the above scans, the emissions were maximized by cable manipulation.

AC Power Conducted Emission Limit

For intentional device, according to § 15.207(a) AC Power Conducted Emission Limits is as following :

Frequency range (MHz)	Limit (dBuV)	
	Quasi-peak	Average
0.15-0.5	66 to 56*	56 to 46*
0.5-5	56	46
5-30	60	50

* Decreases with the logarithm of the frequency.

TEST RESULTS

Remark:

1.WIFI modes were test at 802.11b/802.11g/802.11n (H20) (Low, Middle, and High channel); only the worst result of 802.11b Middle Channel was reported as below:

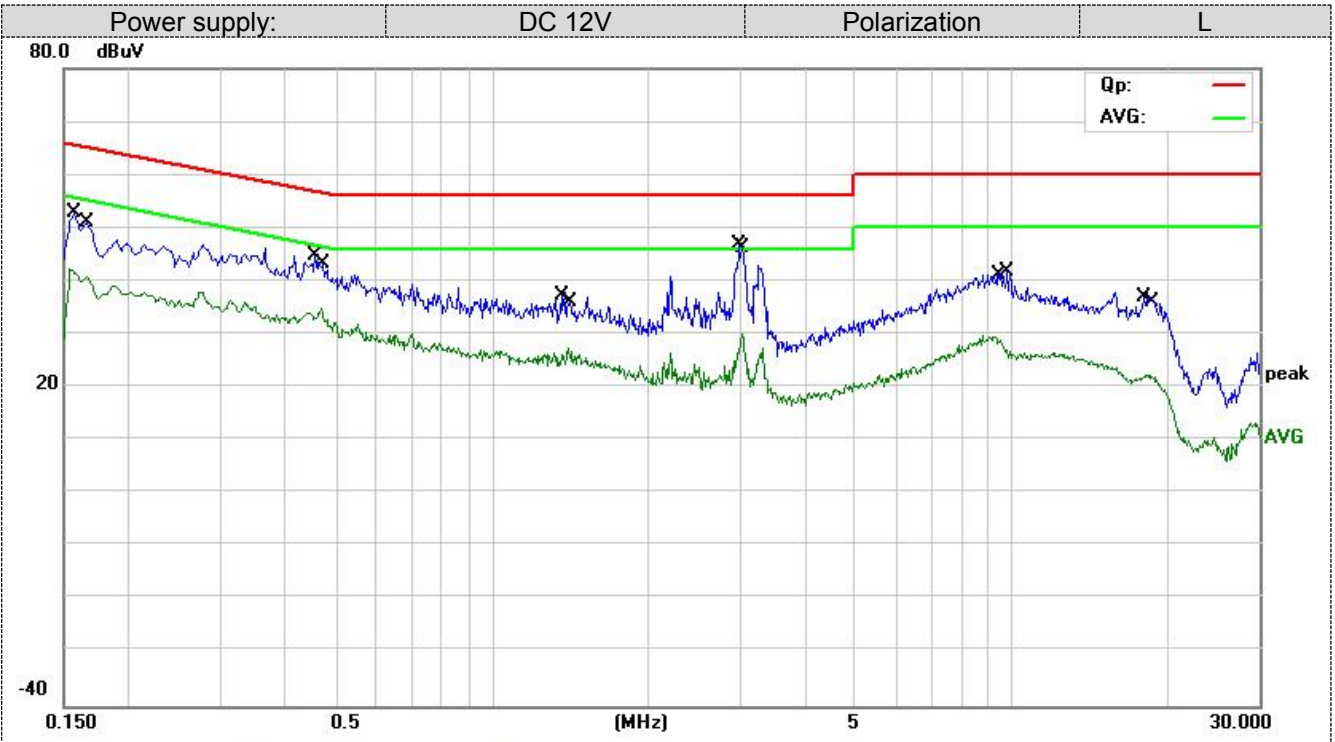

No.	Mk.	Freq. MHz	Reading Level dBuV	Correct Factor dB	Measure- ment dBuV	Limit dBuV	Over dB	Detector	Comment
1		0.1590	31.53	9.60	41.13	55.52	-14.39	AVG	
2		0.1660	41.38	9.61	50.99	65.16	-14.17	QP	
3		0.4580	35.30	9.59	44.89	56.73	-11.84	QP	
4		0.4700	25.15	9.59	34.74	46.51	-11.77	AVG	
5		1.3660	27.55	9.60	37.15	56.00	-18.85	QP	
6		1.4060	17.71	9.60	27.31	46.00	-18.69	AVG	
7	*	3.0060	37.34	9.61	46.95	56.00	-9.05	QP	
8		3.0260	20.35	9.61	29.96	46.00	-16.04	AVG	
9		9.5220	19.03	9.68	28.71	50.00	-21.29	AVG	
10		9.8300	32.15	9.69	41.84	60.00	-18.16	QP	
11		17.9940	27.32	9.72	37.04	60.00	-22.96	QP	
12		18.8420	12.28	9.72	22.00	50.00	-28.00	AVG	

*:Maximum data x:Over limit !:over margin

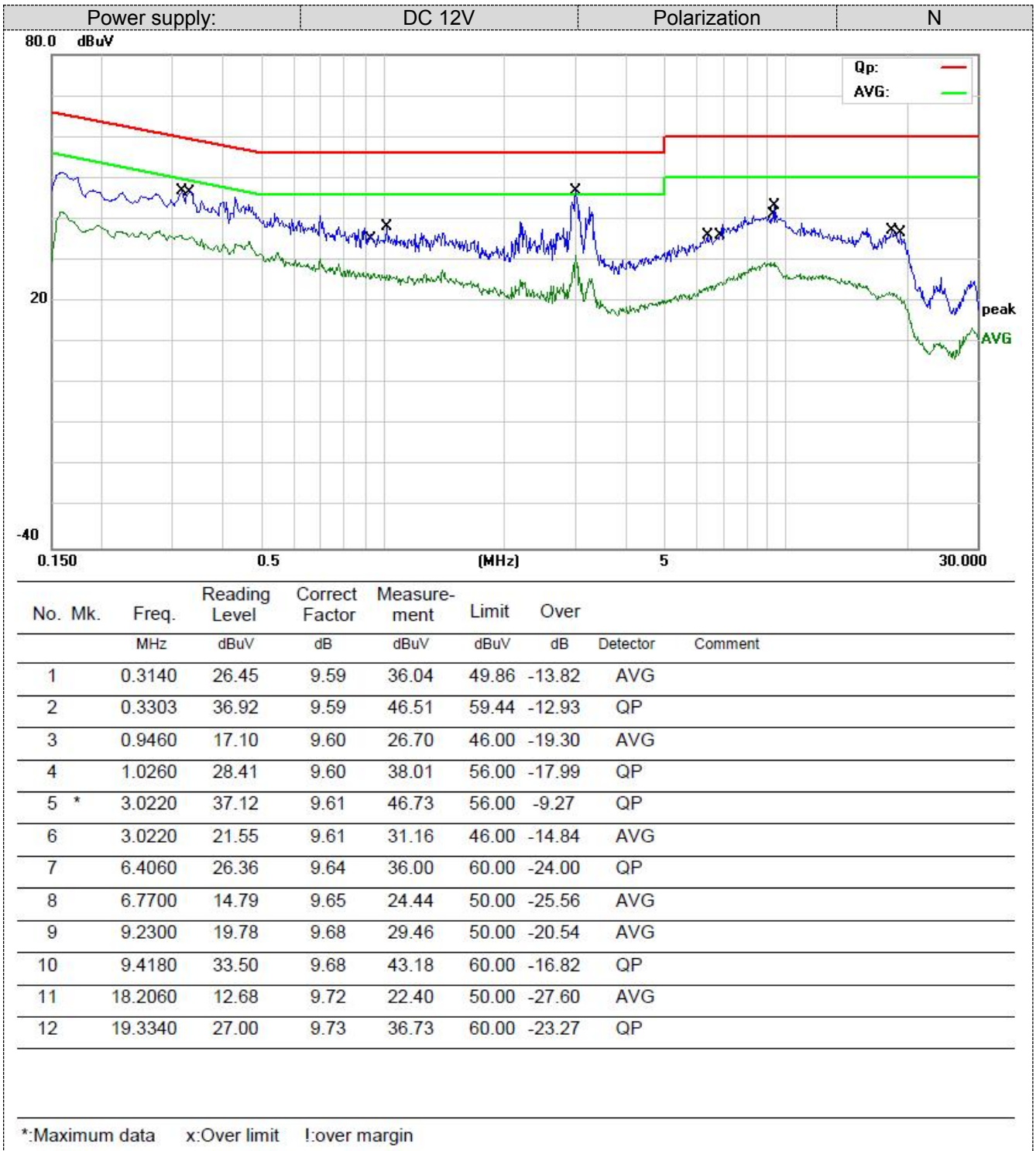

5.2 Radiated Emission

TEST CONFIGURATION

Frequency range 9 KHz – 30MHz

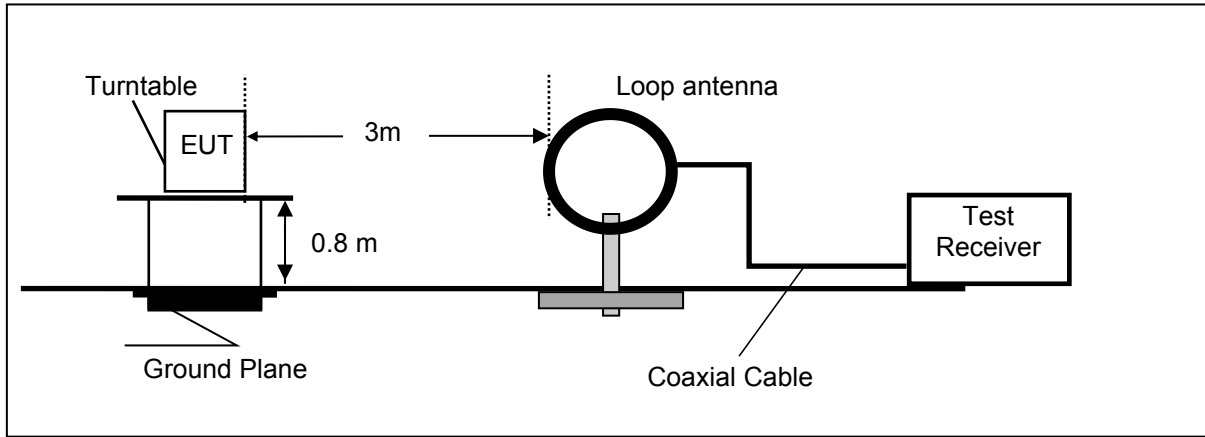

Frequency range 30MHz – 1000MHz

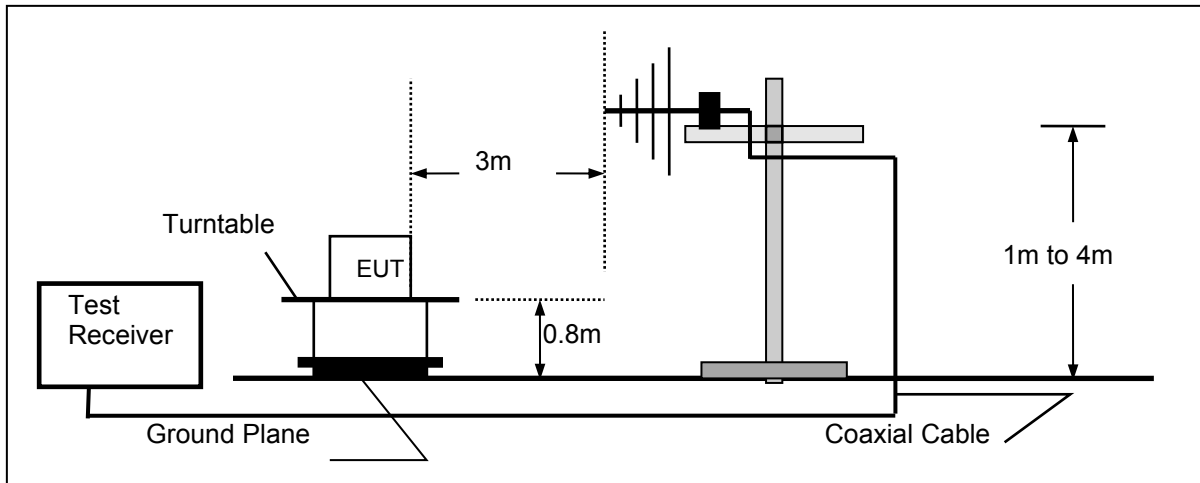

Frequency range above 1GHz-25GHz

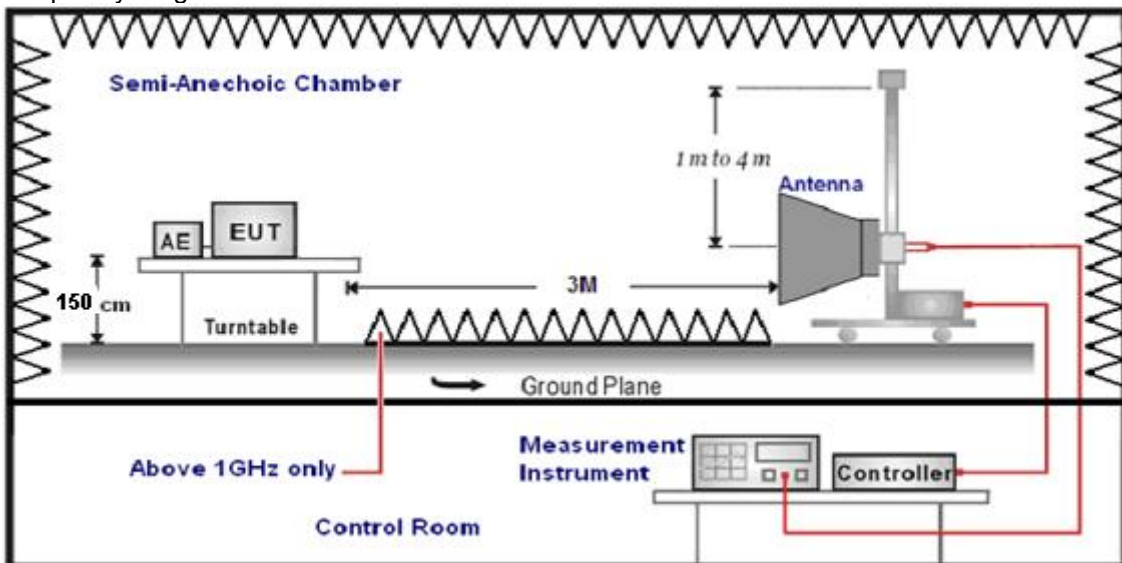

TEST PROCEDURE

1. The EUT was placed on a turn table which is 0.8m above ground plane when testing frequency range 9 KHz –1GHz;the EUT was placed on a turn table which is 1.5m above ground plane when testing frequency range 1GHz – 25GHz.
2. Maximum procedure was performed by raising the receiving antenna from 1m to 4m and rotating the turn table from 0° to 360° to acquire the highest emissions from EUT.
3. And also, each emission was to be maximized by changing the polarization of receiving antenna both horizontal and vertical.
4. Repeat above procedures until all frequency measurements have been completed.
5. Radiated emission test frequency band from 9KHz to 25GHz.
6. The distance between test antenna and EUT as following table states:

Test Frequency range	Test Antenna Type	Test Distance
9KHz-30MHz	Active Loop Antenna	3
30MHz-1GHz	Ultra-Broadband Antenna	3
1GHz-18GHz	Double Ridged Horn Antenna	3
18GHz-25GHz	Horn Antenna	1

7. Setting test receiver/spectrum as following table states:

Test Frequency range	Test Receiver/Spectrum Setting	Detector
9KHz-150KHz	RBW=200Hz/VBW=3KHz,Sweep time=Auto	QP
150KHz-30MHz	RBW=9KHz/VBW=100KHz,Sweep time=Auto	QP
30MHz-1GHz	RBW=120KHz/VBW=1000KHz,Sweep time=Auto	QP
1GHz-40GHz	Peak Value: RBW=1MHz/VBW=3MHz, Sweep time=Auto Average Value: RBW=1MHz/VBW=10Hz, Sweep time=Auto	Peak

Field Strength Calculation

The field strength is calculated by adding the Antenna Factor and Cable Factor and subtracting the Amplifier Gain and Duty Cycle Correction Factor(if any) from the measured reading. The basic equation with a sample calculation is as follows:

FS = RA + AF + CL - AG

Where	FS = Field Strength	CL = Cable Attenuation Factor (Cable Loss)
	RA = Reading Amplitude	AG = Amplifier Gain
	AF = Antenna Factor	

Transd=AF +CL-AG

RADIATION LIMIT

For intentional device, according to § 15.209(a), the general requirement of field strength of radiated emission from intentional radiators at a distance of 3 meters shall not exceed the following table. According to § 15.247(d), in any 100kHz bandwidth outside the frequency band in which the EUT is operating, the radio frequency power that is produced by the intentional radiator shall be at least 20dB below that in the100kHz bandwidth within the band that contains the highest level of desired power.

The pre-test have done for the EUT in three axes and found the worst emission at position shown in test setup photos.

Frequency (MHz)	Distance (Meters)	Radiated (dBµV/m)	Radiated (µV/m)
0.009-0.49	3	20log(2400/F(KHz))+40log(300/3)	2400/F(KHz)
0.49-1.705	3	20log(24000/F(KHz))+ 40log(30/3)	24000/F(KHz)
1.705-30	3	20log(30)+ 40log(30/3)	30
30-88	3	40.0	100
88-216	3	43.5	150
216-960	3	46.0	200
Above 960	3	54.0	500

TEST RESULTS

Remark:

1. This test was performed with EUT in X, Y, Z position and the worse case was found when EUT in X position.
2. All three channels (lowest/middle/highest) of each mode were measured below 1GHz and recorded worst case at 802.11b low channel.
3. Radiated emission test from 9 KHz to 10th harmonic of fundamental was verified, and no emission found except system noise floor in 9 KHz to 30MHz and not recorded in this report.
4. Remark: Result=Reading value+Factor

For 30MHz-1GHz

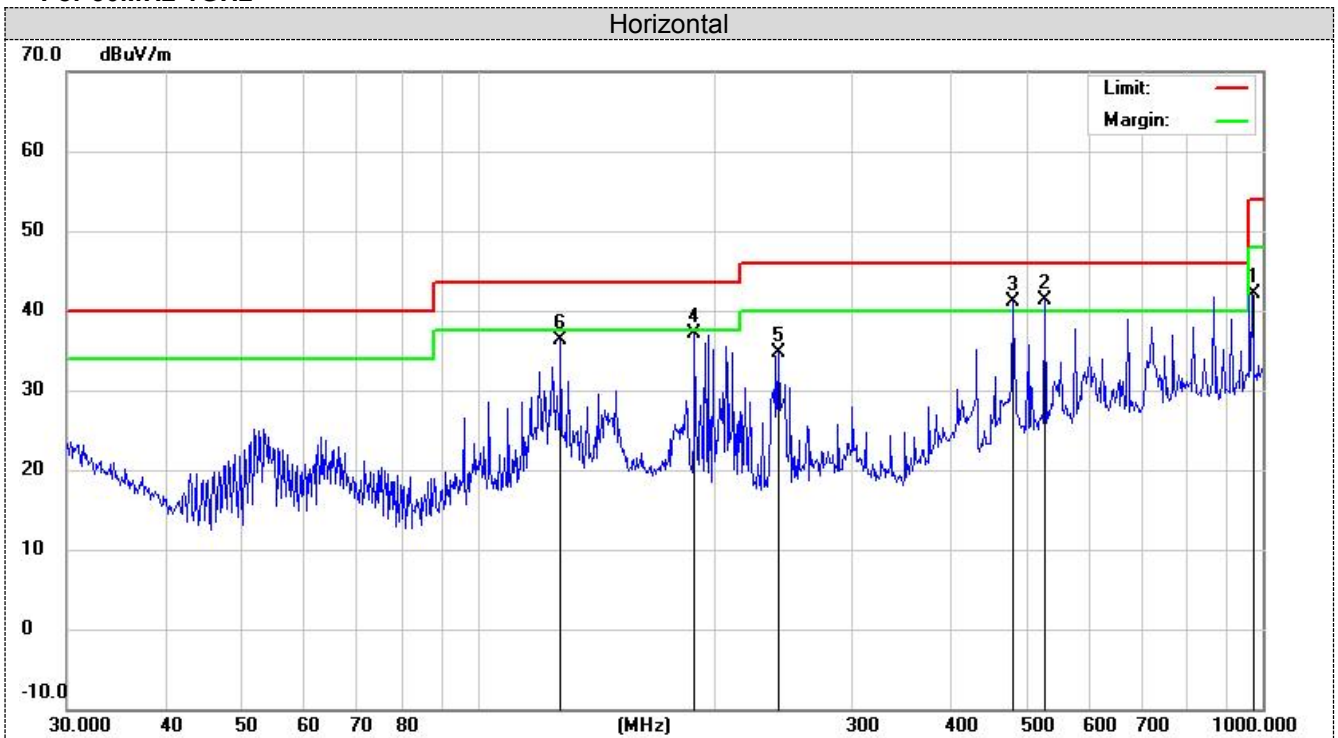

No.	Mk.	Freq. MHz	Reading Level dBuV	Correct Factor dB	Measure- ment dBuV/m	Limit dBuV/m	Over dB	Detector	Antenna Height cm	Table Degree	Comment
1		968.9338	12.38	29.69	42.07	54.00	-11.93	QP	200	158	
2	*	528.2458	18.28	23.01	41.29	46.00	-4.71	QP	200	116	
3	!	480.5276	19.39	21.67	41.06	46.00	-4.94	QP	200	258	
4		189.0743	22.32	14.87	37.19	43.50	-6.31	QP	200	361	
5		241.6763	20.70	14.03	34.73	46.00	-11.27	QP	200	114	
6		127.6645	20.30	16.07	36.37	43.50	-7.13	QP	200	251	

*:Maximum data x:Over limit !:over margin

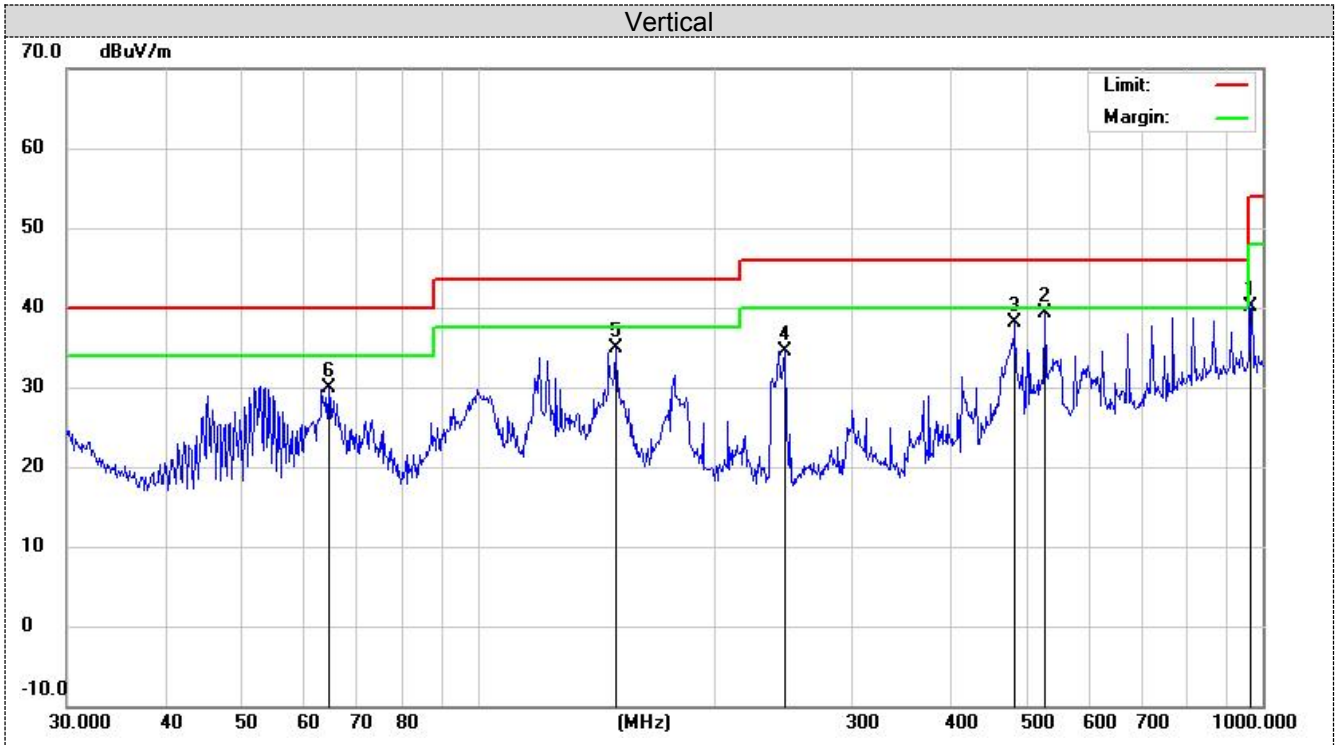

No.	Mk.	Freq. MHz	Reading Level dBuV	Correct Factor dB	Measure- ment dBuV/m	Limit dBuV/m	Over dB	Antenna Height cm	Table Degree degree	Comment
1		962.1623	10.41	29.62	40.03	54.00	-13.97	QP	100	187
2	*	528.2458	16.32	23.01	39.33	46.00	-6.67	QP	100	117
3		483.9094	16.17	21.85	38.02	46.00	-7.98	QP	100	169
4		245.9509	20.69	13.91	34.60	46.00	-11.40	QP	100	254
5		150.0108	17.13	17.70	34.83	43.50	-8.67	QP	100	136
6		64.6594	20.88	8.93	29.81	40.00	-10.19	QP	100	

*:Maximum data x:Over limit !:over margin

For 1GHz to 25GHz

Note: 802.11b/802.11g/802.11n (H20) all have been tested, only worse case 802.11b mode is reported

Polar (H/V)	Frequency (MHz)	Meter Reading (dBuV)	Antenna Factor (dB)	Cable loss (dB)	Preamp factor (dB)	Emission Level (dBuV/m)	Limits (dBuV/m)	Margin (dB)	Detector Type
802.11b-2412MHz									
V	4824	53.47	30.28	7.01	36.5	54.26	74	19.74	PK
V	4824	41.8	30.28	7.01	36.5	42.59	54	11.41	AV
H	4824	56.42	30.28	7.01	36.5	57.21	74	16.79	PK
H	4824	43.84	30.28	7.01	36.5	44.63	54	9.37	AV
V	7236	43.26	36.59	8.91	35.3	53.46	74	20.54	PK
V	7236	31.92	36.59	8.91	35.3	42.12	54	11.88	AV
H	7236	41.59	36.59	8.91	35.3	51.79	74	22.21	PK
H	7236	29.52	36.59	8.91	35.3	39.72	54	14.28	AV
802.11b -2437MHz									
V	4874	54.09	30.36	7.62	36.5	55.57	74	18.43	PK
V	4874	44.46	30.36	7.62	36.5	45.94	54	8.06	AV
H	4874	56.18	30.36	7.62	36.5	57.66	74	16.34	PK
H	4874	40.75	30.36	7.62	36.5	42.23	54	11.77	AV
V	7311	43.24	36.61	8.84	35.3	53.39	74	20.61	PK
V	7311	29.87	36.61	8.84	35.3	40.02	54	13.98	AV
H	7311	39.15	36.61	8.84	35.3	49.3	74	24.7	PK
H	7311	30.02	36.61	8.84	35.3	40.17	54	13.83	AV
802.11b -2462MHz									
V	4924	53.72	30.43	7.94	36.2	55.89	74	18.11	PK
V	4924	40.75	30.43	7.94	36.2	42.92	54	11.08	AV
H	4924	56.43	30.43	7.94	36.2	58.6	74	15.4	PK
H	4924	43.79	30.43	7.94	36.2	45.96	54	8.04	AV
V	7386	41.45	36.78	8.45	35.3	51.38	74	22.62	PK
V	7386	29.85	36.78	8.45	35.3	39.78	54	14.22	AV
H	7386	43.62	36.78	8.45	35.3	53.55	74	20.45	PK
H	7386	29.4	36.78	8.45	35.3	39.33	54	14.67	AV

Note:

- 1) Emission level (dBuV/m) = Meter Reading+ antenna Factor+ cable loss- preamp factor.
- 2) Margin value = Limits-Emission level.
- 3) -- Mean the PK detector measured value is below average limit.
- 4) The other emission levels were very low against the limit.
- 5) RBW1MHz VBW3MHz Peak detector is for PK value; RBW 1MHz VBW10Hz Peak detector is for AV value.

Results of Band Edges Test (Radiated)

Polar (H/V)	Frequency	Meter Reading	Antenna Factor	Cable loss	Preamp factor	Emission Level	Limits	Margin	Detector Type
	(MHz)	(dBuV)	(dB)	(dB)	(dB)	(dBuV/m)	(dBuV/m)	(dB)	
802.11b -2412MHz									
V	2390	59.47	27.49	3.32	36.22	54.06	74	19.94	PK
V	2390	44.48	27.49	3.32	36.22	39.07	54	14.93	AV
H	2390	58.73	27.49	3.32	36.22	53.32	74	20.68	PK
H	2390	43.1	27.49	3.32	36.22	37.69	54	16.31	AV
V	2400	56.02	27.55	3.41	36.22	50.76	74	23.24	PK
V	2400	47.17	27.55	3.41	36.22	41.91	54	12.09	AV
H	2400	59.84	27.55	3.41	36.22	54.58	74	19.42	PK
H	2400	46.33	27.55	3.41	36.22	41.07	54	12.93	AV
802.11b -2462MHz									
V	2483.5	56.92	27.45	3.38	36.34	51.41	74	22.59	PK
V	2483.5	46.63	27.45	3.38	36.34	41.12	54	12.88	AV
H	2483.5	57.03	27.45	3.38	36.34	51.52	74	22.48	PK
H	2483.5	45.03	27.45	3.38	36.34	39.52	54	14.48	AV
V	2500	55.63	27.41	3.47	36.35	50.16	74	23.84	PK
V	2500	47.63	27.41	3.47	36.35	42.16	54	11.84	AV
H	2500	55.48	27.41	3.47	36.35	50.01	74	23.99	PK
H	2500	44.92	27.41	3.47	36.35	39.45	54	14.55	AV

Polar (H/V)	Frequency	Meter Reading	Antenna Factor	Cable loss	Preamp factor	Emission Level	Limits	Margin	Detector Type
	(MHz)	(dBuV)	(dB)	(dB)	(dB)	(dBuV/m)	(dBuV/m)	(dB)	
802.11g -2412MHz									
V	2390	57.4	27.49	3.32	36.22	51.99	74	22.01	PK
V	2390	44.68	27.49	3.32	36.22	39.27	54	14.73	AV
H	2390	56.35	27.49	3.32	36.22	50.94	74	23.06	PK
H	2390	44.26	27.49	3.32	36.22	38.85	54	15.15	AV
V	2400	55.96	27.55	3.41	36.22	50.7	74	23.3	PK
V	2400	45.15	27.55	3.41	36.22	39.89	54	14.11	AV
H	2400	57.55	27.55	3.41	36.22	52.29	74	21.71	PK
H	2400	44.92	27.55	3.41	36.22	39.66	54	14.34	AV
802.11g -2462MHz									
V	2483.5	58.32	27.45	3.38	36.34	52.81	74	21.19	PK
V	2483.5	45.39	27.45	3.38	36.34	39.88	54	14.12	AV
H	2483.5	59.83	27.45	3.38	36.34	54.32	74	19.68	PK
H	2483.5	47.91	27.45	3.38	36.34	42.4	54	11.6	AV
V	2500	59.88	27.41	3.47	36.35	54.41	74	19.59	PK
V	2500	45.76	27.41	3.47	36.35	40.29	54	13.71	AV
H	2500	56.56	27.41	3.47	36.35	51.09	74	22.91	PK
H	2500	47.72	27.41	3.47	36.35	42.25	54	11.75	AV