

SolidRun SolidSense Compact

The IoT Gateway is a multi-protocol gateway that can simultaneously receive data from multiple wireless protocols. It is designed for commercial facilities and building installations. The Gateway has built-in radios to allow for direct communication with sensors in the IoT Sensor Solution product family. Multiple gateways can be installed to support thousands of sensors.

Regulatory Compliance and Safety Information

Electrical equipment should be installed, operated, serviced, and maintained only by qualified personnel. No responsibility is assumed by SolidRun for any consequences arising out of the use of this material.

Carefully read these instructions and all information relevant to this product before trying to install it. See the list of technical literature.

Dimensions

mm (inches)

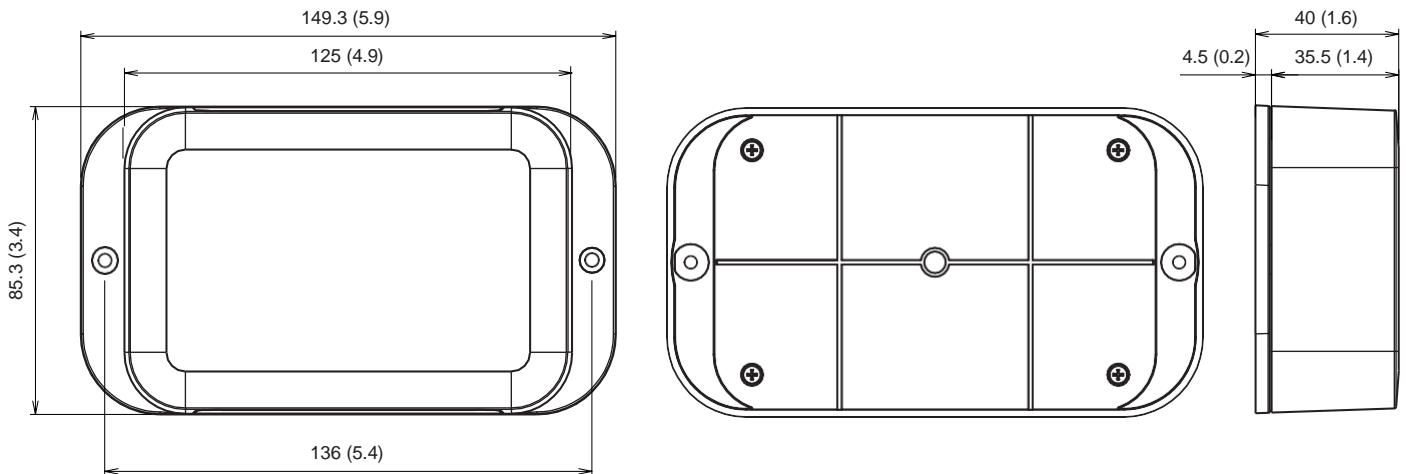

Installation Restrictions

NOTICE

REDUCED DEVICE PERFORMANCE

- This device is for indoor use only and is not suitable for wet locations.
- Do not install the device close to an exterior window.
- When replacing a device, install the new device in the same position and direction as the replaced device.

Failure to follow these instructions can result in reduced device performance.

Installing the Device

1. For models with LTE option: Install the antenna^a.
2. Use adapted screws to install the gateway on the wall.
3. Power on the gateway using the power adapter^a or Power over Ethernet (PoE).

The green LED will turn on solid to indicate the device is operational. Otherwise, press the on/off button to power it up.

Connections and Buttons

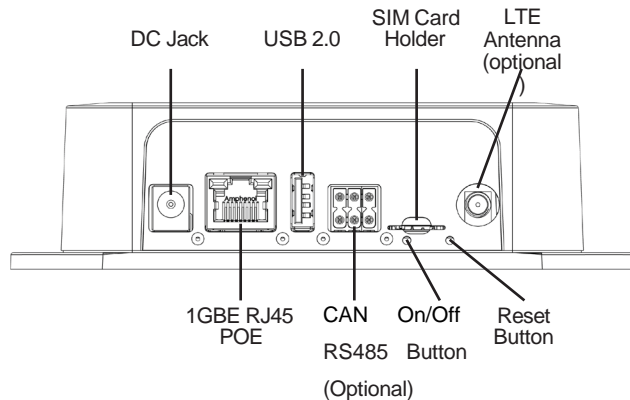

Part Numbers

| Product Code / model number: SRG0400 | Part Numbers |
|--|--------------|
| SolidSense Compact | SRG04XX.0XSX |
| AC/DC Power supply (to be ordered separately) | PA00052 |
| LTE Antenna (To be ordered separately for models supporting LTE) | AN00010 |

General Specifications

| | | |
|--|---|---|
| Maximum number of supported devices IoT Sensor Solution sensors 200 Material Enclosure Plastic casing with internal antenna for Wi-Fi/Bluetooth. One SMA port for LTE. Mechanical Dimensions 150L x 85W x 40H mm (5.9L x 3.3W x 1.6H in) Weight 185 g (0.4 lb) Electrical Power DC 9 - 36 V Power over Ethernet (PoE) PD IEEE802.3AF 5W peak power Hardware RAM 1GB DDR4 Storage capacity 8GB eMMC | Connectors 1 x RS485 (option) 1 x CAN (option) 1 x USB 2.0 Connector, Type-A 1 x DC 9V - 36V power supply Wireless connectivity Communication protocol 2.4 GHz, Sensor Network supporting Mesh Technology Antenna type Omnidirectional, internal. WiFi Interface 2.4GHz/5GHz b/g/n/ac module Antenna type Omnidirectional, internal. FCC ID: 2BA24LBEE5HY1MW, IC: 12107A-LBEE5HY1MW LTE (Optional) 1 x LTE Cat 4 Worldwide + GPS (with fallback on 3G/2G) FCC ID: XMR201903EG25G IC: 10224A-201903EG25G | Optional AC/DC Power supply Model ICP12-120-1000D Input AC 100-240V Output DC 12V-1A @ 40°C Environment Environmental conditions Indoor use only Ambient temperature, operating 0 to 50 °C (32 to 122 °F) Ambient temperature, storage -20 to 65 °C (-4 to 149 °F) Humidity 0 to 95 % (non-condensing) Installation Mounting Wall-mounted Installation equipment, included Mounting tape, screws, installation instructions |
|--|---|---|

FCC ID: 2BA240-SRG0400, IC: 12107A-SR0400

Addendum - California Proposition 65 Warning Statement for California Residents

⚠ WARNING: This product can expose you to chemicals including Lead, which is known to the State of California to cause cancer and birth defects or other reproductive harm, and Bisphenol A (BPA), which is known to the State of California to cause birth defects or other reproductive harm. For more information, go to www.P65Warnings.ca.gov.

| 部件名称 (Part Name) | 有害物质 (Hazardous Substances) | | | | | |
|----------------------|-----------------------------|--------|--------|---------------|------------|--------------|
| | 铅 (Pb) | 汞 (Hg) | 镉 (Cd) | 六价铬 (Cr (VI)) | 多溴联苯 (PBB) | 多溴二苯醚 (PBDE) |
| 塑料部件 (Plastic Parts) | ○ | ○ | ○ | ○ | ○ | ○ |
| 电子件 (Electronics) | X | ○ | ○ | ○ | ○ | ○ |

本表格依据 SJ/T11364 的规定编制。(This table is made according to SJ/T 11364.)

○: 表示该有害物质在该部件所有均质材料中的含量均在 GB/T 26572 规定的限量要求以下。
(Indicates that the concentration of hazardous substance in all of the homogeneous materials for this part is below the limit as stipulated in GB/T 26572.)

X: 表示该有害物质至少在该部件的某一均质材料中的含量超出 GB/T 26572 规定的限量要求。
(Indicates that the concentration of hazardous substance in at least one of the homogeneous materials used for this part is above the limit as stipulated in GB/T 26572.)

A

Regulatory Notices

This equipment has been tested and found to comply with the limits for a Class B digital device, pursuant to part 15 of the FCC Rules. These limits are designed to provide reasonable protection against harmful interference in a residential installation. This equipment generates, uses and can radiate radio frequency energy and, if not installed and used in accordance with the instructions, may cause harmful interference to radio communications. However, there is no guarantee that interference will not occur in a particular installation. If this equipment does cause harmful interference to radio or television reception, which can be determined by turning the equipment off and on, the user is encouraged to try to correct the interference by one or more of the following measures:

- Reorient or relocate the receiving antenna.
- Increase the separation between the equipment and receiver.
- Connect the equipment into an outlet on a circuit different from that to which the receiver is connected.
- Consult the dealer or an experienced radio/TV technician for help.

This device complies with Part 15 of the FCC Rules. Operation is subject to the following two conditions:

- (1) this device may not cause harmful interference, and
- (2) this device must accept any interference received, including interference that may cause undesired operation. Please note that changes or modifications not expressly approved by the party responsible for compliance could void the user's authority to operate the equipment.

Changes or modifications not expressly approved by the party responsible for compliance could void the user's authority to operate the equipment.

This equipment complies with FCC radiation exposure limits set forth for an uncontrolled environment. This transmitter must not be co-located or operating in conjunction with any other antenna or transmitter. In order to avoid the possibility of exceeding the FCC radio frequency exposure limits, this equipment should be installed and operated with minimum distance 20 cm (7.9 inches) between the antenna and your body during normal operation. Users must follow the specific operating instructions for satisfying RF exposure compliance.

This device contains licence-exempt transmitter(s)/receiver(s) that comply with Innovation, Science and Economic Development Canada's licence-exempt RSS(s). Operation is subject to the following two conditions:

- (1) This device may not cause interference.
- (2) This device must accept any interference, including interference that may cause undesired operation of the device.

This device complies with the Canadian ICES-003 Class B specifications. CAN ICES-003(B) / NMB-003 (B).

L'émetteur/récepteur exempt de licence contenu dans le présent appareil est conforme aux CNR d'Innovation, Sciences et Développement économique Canada applicables aux appareils radio exempt de licence. L'exploitation est autorisée aux deux conditions suivantes :

- (1) L'appareil ne doit pas produire de brouillage;
- (2) L'appareil doit accepter tout brouillage radioélectrique subi, même si le brouillage est susceptible d'en compromettre le fonctionnement.

Cet appareil numérique de la Canadian ICES-003. Cet appareil numérique de la classe B est conforme à la norme NMB-003 du Canada.

This equipment complies with ISED RSS-102 radiation exposure limits set forth for an uncontrolled environment. This equipment should be installed and operated with minimum distance 20 cm (7.9 inches) between the radiator and any part of your body. This transmitter must not be co-located or operating in conjunction with any other antenna or transmitter.

Cet équipement est conforme aux limites d'exposition aux radiations ISED CNR-102 établies pour un environnement non contrôlé. Une distance de séparation d'au moins 20 cm doivent être maintenue entre l'antenne de cet appareil et toutes les personnes. Lanceurs ou ne peuvent pas coexister cette antenne ou capteurs avec d'autres.

This radio transmitter IC: 12107A-SRG0400 has been approved by Innovation, Science and Economic Development Canada to operate with the antenna types listed below, with the maximum permissible gain indicated. Antenna types not included in this list that have a gain greater than the maximum gain indicated for any type listed are strictly prohibited for use with this device.

Le présent émetteur radio IC: 12107A-SRG0400 a été approuvé par Innovation, Sciences et Développement économique Canada pour fonctionner avec les types d'antenne énumérés ci-dessous et ayant un gain admissible maximal. Les types d'antenne non inclus dans cette liste, et dont le gain est supérieur au gain maximal indiqué pour tout type figurant sur la liste, sont strictement interdits pour l'exploitation de l'émetteur.

Under Innovation, Science and Economic Development regulations, this radio transmitter may only operate using an antenna of a type and maximum (or lesser) gain approved for the transmitter by ISED. To reduce potential radio interference to other users, the antenna type and its gain should be so chosen that the equivalent isotropically radiated power (e.i.r.p.) is not more than that necessary for successful communication.

Conformément à la réglementation d'Innovation, Sciences et Développement économique Canada, le présent émetteur radio peut fonctionner avec une antenne d'un type et d'un gain maximal (ou inférieur) approuvé pour l'émetteur par Innovation, Sciences et Développement économique Canada. Dans le but de réduire les risques de brouillage radioélectrique à l'intention des autres utilisateurs, il faut choisir le type d'antenne et son gain de sorte que la puissance isotrope rayonnée équivalente (p.i.r.e.) ne dépasse pas l'intensité nécessaire à l'établissement d'une communication satisfaisante.

Approved Antenna Type:

Maximum gain: 3 dBi
 Antenna type: FPC (Flexible Printed Circuit)
 Radiation pattern: Omni-Directional
 Impedance: 50 Ohm
 Connector type: U.FL