

FCC CFR47 PART 22H, 24E, 27 CERTIFICATION TEST REPORT

FCC ID: 2AZYA-D61L

Product: Mobile Phone
Trade Mark: KODAK
Model Number: D61L
Family Model: N/A
Report No.: S22051701203005

Prepared for

Senwa Global International, S.A. de C.V.
Carretera Mexico-Toluca No. 5324 PB, Colonia El Yaqui, Cuajimalpa
de Morelos, C.P. 05320 Ciudad de Mexico, Mexico

Prepared by

Shenzhen NTEK Testing Technology Co., Ltd.
1/F, Building E, Fenda Science Park, Sanwei Community, Xixiang Street
Bao'an District, Shenzhen 518126 P.R. China
Tel. 400-800-6106, 0755-2320 0050, 0755-2320 0090
Website: <http://www.ntek.org.cn>

TEST RESULT CERTIFICATION

Applicant's name	Senwa Global International, S.A. de C.V.
Address	Carretera Mexico-Toluca No. 5324 PB, Colonia El Yaqui, Cuajimalpa de Morelos, C.P. 05320 Ciudad de Mexico, Mexico
Manufacturer's Name	Senwa Mobile China Ltd
Address	A611, Languang technology building, No. 27, Gaoxin North 6th Road, songpingshan community, Xili street, Nanshan District, Shenzhen, Guangdong Province
Product name	Mobile Phone
Model and/or type reference ...:	D61L
Family Model:	N/A
Standards	FCC CFR 47 Part 22H, Part 24E, Part 27
Test procedure	ANSI C63.26:2015 ANSI/TIA-603-E-2016
Test Sample Number	S220517012001
<p>This device described above has been tested by NTEK, and the test results show that the equipment under test (EUT) is in compliance with the FCC requirements. And it is applicable only to the tested sample identified in the report.</p> <p>This report shall not be reproduced except in full, without the written approval of NTEK, this document may be altered or revised by NTEK, personal only, and shall be noted in the revision of the document.</p>	
Date of Test	
Date (s) of performance of tests	May 17, 2022 ~ Jun 09, 2022
Date of Issue	Jun 09, 2022
Test Result	Pass

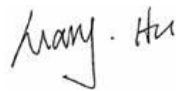
Testing Engineer : 

 (Mary Hu)

Authorized Signatory : 

 (Alex Li)

TABLE OF CONTENTS

1.1 PRODUCT DESCRIPTION	5
1.2 RELATED SUBMITTAL(S) / GRANT (S).....	5
1.3 TEST METHODOLOGY	6
1.4 TEST FACILITY.....	6
MEASUREMENT UNCERTAINTY	6
1.5 SPECIAL ACCESSORIES.....	6
1.6 WORST-CASE CONFIGURATION AND MODE.....	6
1.6 SUMMARY OF TEST RESULTS	7
2. SYSTEM TEST CONFIGURATION	9
2.1 EUT CONFIGURATION.....	9
2.2 EUT EXERCISE	9
2.3 CONFIGURATION OF EUT SYSTEM.....	9
2.4 TEST SETUP	10
3.TEST AND MEASUREMENT EQUIPMENT	11
4. OUTPUT POWER.....	13
4.1 OUTPUT POWER MEASUREMENT	13
6. BANDEDGE AND EMISSION MASK	16
7. OUT OF BAND EMISSIONS.....	17
7.1 MEASUREMENT METHOD	18
8. RADIATED MEASUREMENT	19
8.1. RADIATED POWER (ERP & EIRP).....	19
8.2 LTE BAND 2	20
8.3 LTE BAND 4	24
8.4 LTE BAND 5	28
8.5 LTE BAND 7	30
8.6 LTE BAND66	32

9. SPURIOUS RADIATION EMISSION36

9.1 LTE BAND 2 38

9.2 LTE BAND 4 40

9.3 LTE BAND 5 42

9.4 LTE BAND 7 44

9.5 LTE BAND 66 46

10. FREQUENCY STABILITY48

10.1 LTE BAND 2 49

10.2 LTE BAND 4 51

10.3 LTE BAND 5 53

10.4 LTE BAND 7 55

10.5 LTE BAND 66 57

11. PEAK-TO-AVERAGE RATIO59

11.1 Description of the PAR Measurement 59

11.2 Measuring Instruments 59

11.3 Test Procedures 59

11.4 Test Setup 59

1. GENERAL INFORMATION

1.1 PRODUCT DESCRIPTION

A major technical description of EUT is described as following:

Product Designation:	Mobile Phone
Trade Mark	KODAK
Model Name	D61L
Family Model	N/A
Model Difference	N/A
FCC ID:	2AZYA-D61L
Frequency Bands:	U.S. Bands: <input checked="" type="checkbox"/> LTE FDD Band 2, 4, 5,7, 66
Frequency Range:	LTE FDD Band 2 Uplink: 1850MHz-1910MHz, Downlink: 1930MHz-1990MHz; LTE FDD Band 4 Uplink: 1710MHz-1755MHz, Downlink: 2110MHz-2155MHz; LTE FDD Band 5 Uplink: 824MHz-849MHz, Downlink: 869MHz-894MHz; LTE-FDD Band 7 Uplink: 2500MHz-2570MHz, Downlink: 2620MHz-2690MHz; LTE FDD Band 66 Uplink: 1710MHz-1780MHz, Downlink: 2110MHz-2200MHz;
Type of Modulation:	QPSK/16QAM
Power Class	Class 3
Antenna:	PIFA Antenna
Antenna gain:	Band 2:1.2dBi; Band 4:1.0dBi; Band 5:0.6dBi; Band 7:1.5dBi; Band 66:0.5dBi;
Adapter	Model: KODAK Input: 100-240V~50/60Hz 0.2A Max Output: 5.0V---1.0A
Battery	DC 3.8V, 3000mAh,11.4Wh
Power supply	DC 3.8V from battery or DC 9V from Adapter.
Extreme Vol. Limits:	DC 3.4V to DC 4.2V (Nominal DC 3.8V) (Note 1)
HW Version	sp9832e_1h10_go
SW Version	Kodak_D61L_ARG_Ver01
** Note1: The High Voltage 4.2V and Low Voltage 3.4V was declared by manufacturer, The EUT couldn't be operate normally with higher or lower voltage.	

1.2 RELATED SUBMITTAL(S) / GRANT (S)

This submittal(s) (test report) is intended for **FCC ID: 2AZYA-D61L** filing to comply with the FCC Part 22H&24E &27.

1.3 TEST METHODOLOGY

The tests documented in this report were performed in accordance with ANSI/TIA-603-E-2016, FCC CFR 47 Part 2, Part 22, Part 24, Part 27, ANSI C63.26:2015.

1.4 TEST FACILITY

The test site used to collect the radiated data is located at:

ShenZhen NTEK Testing Technology Co., Ltd.

1/F, Building E, Fenda Science Park, Sanwei Community, Xixiang Street, Bao'an District, Shenzhen 518126 P.R.China.

The test site is constructed and calibrated to meet the FCC requirements in documents ANSI C63.26:2015& ANSI C63.4: 2014.

FCC Registration No.:463705

IC Registration No.:9270A-1,

CNAS Registration No.:L5516

MEASUREMENT UNCERTAINTY

The reported uncertainty of measurement, where expanded uncertainty U is based on a standard uncertainty multiplied by a coverage factor of k=2, providing a level of confidence of approximately 95 %.

No.	Item	Uncertainty
1	Measuring Uncertainty for a Level of Confidence of 95% ($U = 2Uc(y)$)	2.5dB
2	Conducted Emission Test	± 1.38 dB
3	RF power, conducted	± 0.16 dB
4	Spurious emissions, conducted	± 0.21 dB
5	All emissions, radiated(<1G)	± 4.68 dB
6	All emissions, radiated(>1G)	± 4.89 dB
7	Temperature	$\pm 0.5^{\circ}$ C
8	Humidity	$\pm 2\%$
9	Frequency error, conducted	± 0.19 ppm

1.5 SPECIAL ACCESSORIES

The battery and the charger, earphone supplied by the applicant were used as accessories and being tested with EUT intended for FCC grant together.

1.6 WORST-CASE CONFIGURATION AND MODE

The worst-case scenario for all measurements is based on the investigation results.

The device has LTE Bands of: Band 2, Band 4, Band 5, Band 7, Band 66

The RB Size was selected to measure for peak or average ERP and EIRP, which was based on the conducted power verification baseline data.

For the fundamental investigation of radiated emissions, the EUT is investigated for vertical and horizontal antenna orientations and X Y and Z orientations of the EUT alone. After the investigations the worst case was determined to be at X orientation for all LTE bands.

1.6 SUMMARY OF TEST RESULTS

FCC Part22, FCC Part24, FCC Part27, KDB 971168 D01 Power Meas License Digital Systems v03			
FCC Rule	Test Item	Verdict	Remark
2.1046	Conducted Output Power	PASS	
22.913(d) 24.232(d) 27.50(d)(5) KDB 971168 D01 Clause 5.7	Peak-to-Average Ratio	PASS	
2.1049 22.917(b) 24.238(b) KDB 971168 D01 Clause 4.2	Occupied Bandwidth	PASS	
2.1051 22.917(a) 24.238(a) 27.53(m), (g), (h) KDB 971168 D01 Clause 6	Band Edge	PASS	
22.913(a)(2) 27.50(c)(10) KDB 971168 D01 Clause 5.6	Effective Radiated Power	PASS	
24.232(c) 27.50(h)(2), (d)(4) KDB 971168 D01 Clause 5.6	Equivalent Isotropic Radiated Power	PASS	
2.1053 22.917(a) 24.238(a) 27.53(g)(h)(m) KDB 971168 D01 Clause 7	Field Strength of Spurious Radiation	PASS	

2.1055 22.355 24.235 27.54 KDB 971168 D01 Clause 9	Frequency Stability for Temperature & Voltage	PASS	
2.1051 22.917(a) 24.238(a) 27.53(g)(h)(m) KDB 971168 D01 Clause 6	Conducted Emission	PASS	
Remark: 1. "N/A" denotes test is not applicable in this Test Report. 2. All test items were verified and recorded according to the standards and without any deviation during the test. 3. No modifications are made to the EUT during all test items.			

2. SYSTEM TEST CONFIGURATION

2.1 EUT CONFIGURATION

The EUT configuration for testing is installed on RF field strength measurement to meet the Commission's requirement and operating in a manner which intends to maximize its emission characteristics in a continuous normal application.

2.2 EUT EXERCISE

The Transmitter was operated in the maximum output power mode through Communication Tester. The TX frequency was fixed which was for the purpose of the measurements.

2.3 CONFIGURATION OF EUT SYSTEM

Table 2-1 Equipment Used in EUT System

Item	Equipment	Model No.	ID or Specification	Note
1	Mobile Phone	D61L	FCC ID: 2AZYA-D61L	EUT

*Note: All the accessories have been used during the test.
the following "EUT" in setup diagram means EUT system.*

2.4 TEST SETUP

For Radiated Test Cases

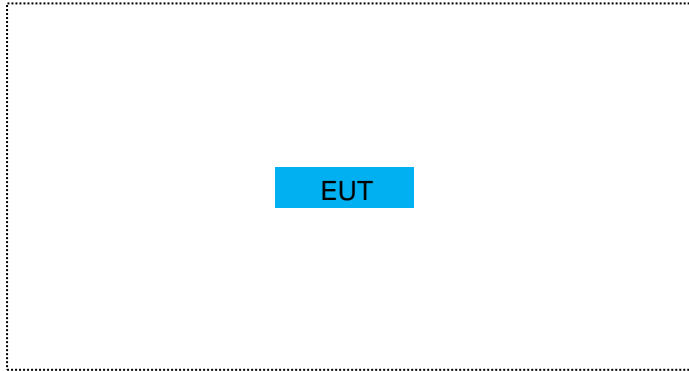

For Conducted Output Power

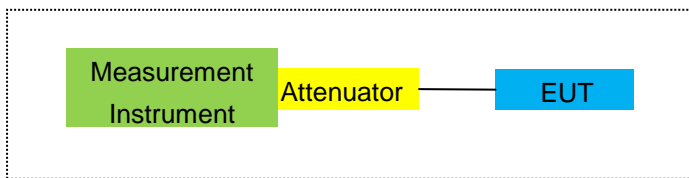

For Peak-to Average Ratio, Occupied Bandwidth, Conducted Band edge and Conducted Spurious Emission

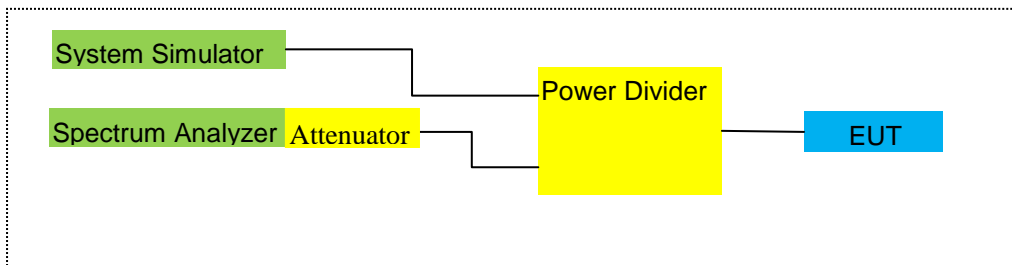

For Frequency Stability

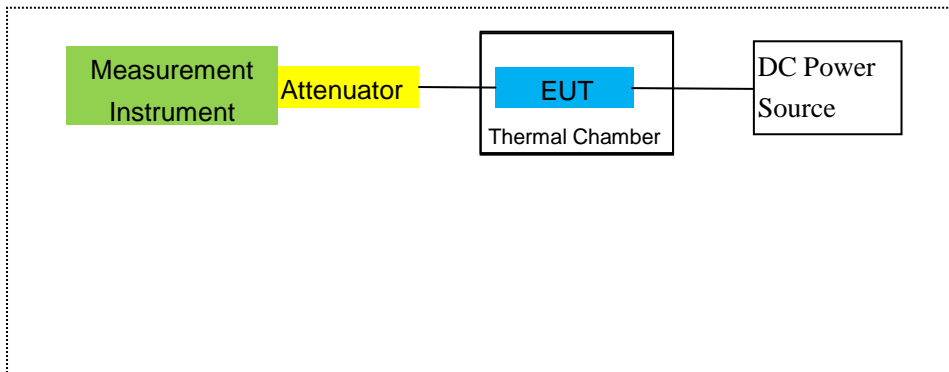

Note: EUT built-in battery-powered, the battery is fully-charged.

3. TEST AND MEASUREMENT EQUIPMENT

The following test and measurement equipment was utilized for the tests documented in this report:

Item	Kind of Equipment	Manufacturer	Type No.	Serial No.	Last calibration	Calibrated until	Calibration period
1	MXA Signal Analyzer	Agilent	N9020A	MY49100060	2021.07.01	2022.06.30	1 year
2	Test Receiver	R&S	ESPI	101318	2022.04.06	2023.04.05	1 year
3	Bilog Antenna	TESEQ	CBL6111D	31216	2022.03.30	2023.03.29	1 year
4	50Ω Coaxial Switch	Anritsu	MP59B	6200983705	2020.05.11	2023.05.10	3 year
5	Horn Antenna	EM	EM-AH-10180	2011071402	2022.03.31	2023.03.30	1 year
6	Horn Ant	Schwarzbeck	BBHA 9170	9170-181	2021.11.07	2022.11.06	1 year
7	Amplifier	EM	EM-30180	060538	2021.07.01	2022.06.30	1 year
8	Loop Antenna	ARA	PLA-1030/B	1029	2022.04.06	2023.04.05	1 year
9	Power Meter	R&S	NRVS	100696	2021.07.01	2022.06.30	1 year
10	Power Sensor	R&S	URV5-Z4	0395.1619.05	2022.04.06	2023.04.05	1 year
11	Test Cable	N/A	R-01	N/A	2019.08.06	2022.08.05	3 year
12	Test Cable	N/A	R-02	N/A	2019.08.06	2022.08.05	3 year
13	Test Cable	N/A	R-03	N/A	2019.06.28	2022.06.27	3 year
14	Test Receiver	R&S	ESCI	101160	2022.04.06	2023.04.05	1 year
15	LISN	R&S	ENV216	101313	2022.04.06	2023.04.05	1 year
16	LISN	EMCO	3816/2	00042990	2022.04.06	2023.04.05	1 year
17	50Ω Coaxial Switch	Anritsu	MP59B	6200264417	2020.05.11	2023.05.10	3 year
18	Passive Voltage Probe	R&S	ESH2-Z3	100196	2022.04.06	2023.04.05	1 year
19	Test Cable	N/A	C01	N/A	2020.05.11	2023.05.10	3 year
20	Test Cable	N/A	C02	N/A	2020.05.11	2023.05.10	3 year
21	Test Cable	N/A	C03	N/A	2020.05.11	2023.05.10	3 year
22	Attenuator	MCE	24-10-34	BN9258	2020.04.07	2023.04.06	3 year
23	Spectrum Analyzer	agilent	e4440a	us44300399	2022.04.01	2023.03.31	1 year
24	test receiver	R&S	ESCI	a0304218	2022.04.06	2023.04.05	1 year
25	Communication Tester	R&S	CMU200	A0304247	2021.07.01	2022.06.30	1 year
26	Thermal Chamber	Ten Billion	TTC-B3C	TBN-960502	2022.04.06	2023.04.05	1 year

27	DC Power Source	N/A	PS-6005D	2017040292 3	2020.05.11	2023.05.10	3 year
28	PSG Analog Signal Generator	Agilent	E8257D	MY51110112	2021.07.01	2022.06.30	1 year
29	Communication Tester	R&S	CMW500	148500	2021.07.01	2022.06.30	1 year
30	PSG Analog Signal Generator	Agilent	E8257D	MY51110112	2021.07.01	2022.06.30	1 year

Note: Each piece of equipment is scheduled for calibration once a year except the Test Cable& DC Power Source which is scheduled for calibration every 3 years.

4. OUTPUT POWER

4.1 OUTPUT POWER MEASUREMENT

LTE Measurement Procedure:

All LTE bands conducted power peak and average are obtained from the CMW500 telecommunication test set. The following tests were conducted according to the test requirements outlined in section 6.2 of the 3GPP TS36.101 specification.

UE Power Class: 3 (23 +/- 2dBm). The allowed Maximum Power Reduction (MPR) for the maximum output power due to higher order modulation and transmit bandwidth configuration (resource blocks) is specified in Table 6.2.3-1 of the 3GPP TS36.101.

Table 6.2.3-1: Maximum Power Reduction (MPR) for Power Class 3

Modulation	Channel bandwidth / Transmission bandwidth (RB)						MPR (dB)
	1.4 MHz	3.0 MHz	5 MHz	10 MHz	15 MHz	20 MHz	
QPSK	> 5	> 4	> 8	> 12	> 16	> 18	≤ 1
16 QAM	≤ 5	≤ 4	≤ 8	≤ 12	≤ 16	≤ 18	≤ 1
16 QAM	> 5	> 4	> 8	> 12	> 16	> 18	≤ 2

The allowed A-MPR values specified below in Table 6.2.4.-1 of 3GPP TS36.101 are in addition to the allowed MPR requirements. All the measurements below were performed with A-MPR disabled, by using Network Signaling Value of "NS_01".3

Table 6.2.4-1: Additional Maximum Power Reduction (A-MPR)

Network Signalling value	Requirements (sub-clause)	E-UTRA Band	Channel bandwidth (MHz)	Resources Blocks (N_{RB})	A-MPR (dB)
NS_01	6.6.2.1.1	Table 5.5-1	1.4, 3, 5, 10, 15, 20	Table 5.6-1	NA
NS_03	6.6.2.2.1	2, 4, 10, 23, 25, 35, 36	3	>5	≤ 1
			5	>6	≤ 1
			10	>6	≤ 1
			15	>8	≤ 1
			20	>10	≤ 1
NS_04	6.6.2.2.2	41	5	>6	≤ 1
			10, 15, 20	See Table 6.2.4-4	
NS_05	6.6.3.3.1	1	10, 15, 20	≥ 50	≤ 1
NS_06	6.6.2.2.3	12, 13, 14, 17	1.4, 3, 5, 10	Table 5.6-1	n/a
NS_07	6.6.2.2.3	13	10	Table 6.2.4-2	Table 6.2.4-2
	6.6.3.3.2				
NS_08	6.6.3.3.3	19	10, 15	> 44	≤ 3
NS_09	6.6.3.3.4	21	10, 15	> 40	≤ 1
				> 55	≤ 2
NS_10		20	15, 20	Table 6.2.4-3	Table 6.2.4-3
NS_11	6.6.2.2.1	23 ¹	1.4, 3, 5, 10	Table 6.2.4-5	Table 6.2.4-5
..					
NS_32	-	-	-	-	-

Note 1: Applies to the lower block of Band 23, i.e. a carrier placed in the 2000-2010 MHz region.

Test data reference attachment.

5. OCCUPIED BANDWIDTH

RULE PART(S)

FCC: §2.1049

LIMITS

For reporting purposes only

TEST PROCEDURE

The transmitter output was connected to a calibrated coaxial cable and coupler, the other end of which was connected to a spectrum analyzer. The occupied bandwidth was measured with the spectrum analyzer at the low, middle and high channel in each band. The -26dB bandwidth was also measured and recorded.

MODES TESTED

- LTE Band2
- LTE Band 4
- LTE Band 5
- LTE Band 7
- LTE Band 66

RESULTS

PASS

Test data reference attachment.

6. BANDEDGE AND EMISSION MASK

RULE PART(S)

FCC: §2.1051, §22.917(a), §24.238(a), §27.53(c)(g)(h)(m)

FCC: §2.1046, §22.913, §24.232

LIMITS

The minimum permissible attenuation level of any spurious emission is $43 + \log_{10}(P[\text{Watts}])$, where P is the transmitter power in Watts.

The minimum permissible attenuation level for Band 7 is as following.

Per 27.53(g) for operations in the 698-746 MHz band, in the 100 kHz bands immediately outside and adjacent to the frequency block a resolution bandwidth of at least 30 kHz may be employed to demonstrate compliance with the out-of-band emissions limit.

Per 27.53(c.5) for operations in the 776-788 MHz band, in the 100 kHz bands immediately outside and adjacent to the frequency block a resolution bandwidth of at least 30 kHz may be employed to demonstrate compliance with the out-of-band emissions limit.

For all plots showing emissions in the 763 – 775MHz and 793 – 805MHz band, the FCC limit per 27.53(c.4) is $65 + 10\log_{10}(P) = -35\text{dBm}$ in a 6.25kHz bandwidth.

Per 27.53(m) for operations in the BRS/EBS bands, the attenuation factor shall be not less than $40 + 10 \log (P)$ dB on all frequencies between the channel edge and 5 megahertz from the channel edge, $43 + 10 \log (P)$ dB on all frequencies between 5 megahertz and X megahertz from the channel edge, and $55 + 10 \log (P)$ dB on all frequencies more than X megahertz from the channel edge, where X is the greater of 6 megahertz or the actual emission bandwidth.

TEST PROCEDURE

The transmitter output was connected to a CMW500 Test Set and configured to operate at maximum power. The band edge emissions were measured at the required operating frequencies in each band on the Spectrum Analyzer.

For each band edge measurement:

Set the spectrum analyzer span to include the block edge frequency

Set a marker to point the corresponding band edge frequency in each test case.

Set display line

Set resolution bandwidth to at least 1% of emission bandwidth.

MODES TESTED

- LTE Band 2/4/5/7/66

RESULTS

Test data reference attachment.

7. OUT OF BAND EMISSIONS

RULE PART(S)

FCC: §2.1051, §22.917(a), §24.238(a), §27.53(c)(g)(h)(m)

LIMITS

The minimum permissible attenuation level of any spurious emission is $43 + \log_{10}(P[\text{Watts}])$, where P is the transmitter power in Watts.

The minimum permissible attenuation level for Band 7 is as following.

Per 27.53(g) for operations in the 698-746 MHz band, in the 100 kHz bands immediately outside and adjacent to the frequency block a resolution bandwidth of at least 30 kHz may be employed to demonstrate compliance with the out-of-band emissions limit.

Per 27.53(c.5) for operations in the 776-788 MHz band, in the 100 kHz bands immediately outside and adjacent to the frequency block a resolution bandwidth of at least 30 kHz may be employed to demonstrate compliance with the out-of-band emissions limit.

For all plots showing emissions in the 763 – 775MHz and 793 – 805MHz band, the FCC limit per 27.53(c.4) is $65 + 10\log_{10}(P) = -35\text{dBm}$ in a 6.25kHz bandwidth.

Per 27.53(m) for operations in the BRS/EBS bands, the attenuation factor shall be not less than $40 + 10 \log (P)$ dB on all frequencies between the channel edge and 5 megahertz from the channel edge, $43 + 10 \log (P)$ dB on all frequencies between 5 megahertz and X megahertz from the channel edge, and $55 + 10 \log (P)$ dB on all frequencies more than X megahertz from the channel edge, where X is the greater of 6 megahertz or the actual emission bandwidth.

TEST PROCEDURE

The RF output of the transmitter was connected to a spectrum analyzer through a calibrated coaxial cable. Sufficient scans were taken to show the out-of-band Emissions, if any, up to 10th harmonic. Multiple sweeps were recorded in maximum hold mode using a peak detector to ensure that the worst-case emissions were caught.

For each out of band emissions measurement:

- Set display line
- Set RBW & VBW to 100 kHz for the measurement below 1 GHz, and 1 MHz for the measurement above 1 GHz.

MODES TESTED

- LTE Band2
- LTE Band 4
- LTE Band 5
- LTE Band 7
- LTE Band 66

7.1 MEASUREMENT METHOD

The test set up and general procedure is similar to conducted peak output power test. Only different for setting the measurement configuration of the measuring instrument of Spectrum Analyzer.

Test data reference attachment.

Note: the amplitude of spurious emission that is attenuated by more than 20dB below the permissible limit has no need to be reported (LTE Band 2/4/7: above 10GHz).

8. RADIATED MEASUREMENT

8.1. RADIATED POWER (ERP & EIRP)

RULE PART(S)

FCC: §2.1046, §22.913(a)(2), §24.232(c) and §27.50 (h)(2), (b)(10), (c)(10), (d)(4)

LIMITS:

22.913(a) (2)- The ERP of mobile transmitters and auxiliary test transmitters must not exceed 7 Watts.
24.232 (c) Mobile and portable stations are limited to 2 watts EIRP.
27.50 (c) (10) the following power and antenna height requirements apply to stations transmitting in the 698–746 MHz band, the portable stations (hand-held devices) are limited to 3 watts ERP.
27.50 (b)(10) Portable stations (hand-held devices) transmitting in the 746–757 MHz, 758–763 MHz, 776–793 MHz, and 805–806 MHz bands are limited to 3 watts ERP.
27.50 (d)(4) The following power and antenna height requirements apply to stations transmitting in the 1710–1755 MHz and 2110–2155 MHz bands: Fixed, mobile, and portable (hand-held) stations operating in the 1710–1755 MHz band are limited to 1 watt EIRP.
27.50 (h)(2) Mobile and other user stations in the 2500–2570 MHz and 2620–2690 MHz bands. Mobile stations are limited to 2.0 watts EIRP. All user stations are limited to 2.0 watts transmitter output power.

TEST PROCEDURE

ANSI/TIA-603-E Clause 2.2.17

KDB 971168 v02r01 RF power output using broadband peak and average power meter method.

KDB 971168 D01 Power Meas License Digital Systems v02r01, “Measurement Guidance for Certification of Licensed Digital Transmitters”

MODES TESTED

- LTE Band2
- LTE Band 4
- LTE Band 5
- LTE Band 7
- LTE Band 66

RESULTS

Pass

8.2 LTE BAND 2

Radiated Power (EIRP) for Band 2										
Mode	RB/RB SIZE	Frequency	Result						Polarization Of Max. ERP	Conclusion
			SG Level (dBm)	Cable Loss (dBm)	Antenna Gain (dB)	Max. EIRP Average (dBm)	Max. EIRP Average (mW)			
1.4MHz Band QPSK	6/0	1850.7	16.22	3.76	8.90	21.36	136.77	Horizontal	Pass	
		1880	16.70	3.91	8.90	21.69	147.57	Horizontal	Pass	
		1909.3	16.39	3.93	8.90	21.36	136.77	Horizontal	Pass	
3.0MHz Band QPSK	15/0	1851.5	16.26	3.77	8.90	21.39	137.72	Horizontal	Pass	
		1880	16.37	3.91	8.90	21.36	136.77	Horizontal	Pass	
		1908.5	16.69	3.94	8.90	21.65	146.22	Horizontal	Pass	
5.0MHz Band QPSK	25/0	1852.5	16.46	3.77	8.90	21.59	144.21	Horizontal	Pass	
		1880	16.82	3.91	8.90	21.81	151.71	Horizontal	Pass	
		1907.5	16.30	3.94	8.90	21.26	133.66	Horizontal	Pass	
10.0MHz Band QPSK	50/0	1855	15.92	3.79	8.90	21.03	126.77	Horizontal	Pass	
		1880	18.18	3.95	8.90	23.13	205.59	Horizontal	Pass	
		1905	17.68	3.97	8.90	22.61	182.39	Horizontal	Pass	
15.0MHz Band QPSK	75/0	1857.5	16.25	3.79	8.90	21.36	136.77	Horizontal	Pass	
		1880	16.08	3.95	8.90	21.03	126.77	Horizontal	Pass	
		1902.5	16.43	3.97	8.90	21.36	136.77	Horizontal	Pass	
20.0MHz Band QPSK	100/0	1860	16.60	3.81	8.90	21.69	147.57	Horizontal	Pass	
		1880	18.22	3.96	8.90	23.16	207.01	Horizontal	Pass	
		1900	16.56	4.00	8.90	21.46	139.96	Horizontal	Pass	
1.4MHz Band QPSK	6/0	1850.7	17.21	3.76	8.90	22.35	171.79	Vertical	Pass	
		1880	16.23	3.91	8.90	21.22	132.43	Vertical	Pass	
		1909.3	17.39	3.93	8.90	22.36	172.19	Vertical	Pass	
3.0MHz Band QPSK	15/0	1851.5	15.91	3.77	8.90	21.04	127.06	Vertical	Pass	
		1880	16.70	3.91	8.90	21.69	147.57	Vertical	Pass	
		1908.5	17.20	3.94	8.90	22.16	164.44	Vertical	Pass	
5.0MHz Band QPSK	25/0	1852.5	16.88	3.77	8.90	22.01	158.85	Vertical	Pass	
		1880	16.66	3.91	8.90	21.65	146.22	Vertical	Pass	
		1907.5	17.20	3.94	8.90	22.16	164.44	Vertical	Pass	
10.0MHz Band QPSK	50/0	1855	16.25	3.79	8.90	21.36	136.77	Vertical	Pass	
		1880	16.31	3.95	8.90	21.26	133.66	Vertical	Pass	
		1905	16.31	3.97	8.90	21.24	133.05	Vertical	Pass	

15.0MHz Band QPSK	75/0	1857.5	17.05	3.79	8.90	22.16	164.44	Vertical	Pass
		1880	17.04	3.95	8.90	21.99	158.12	Vertical	Pass
		1902.5	17.73	3.97	8.90	22.66	184.50	Vertical	Pass
20.0MHz Band QPSK	100/0	1860	17.06	3.81	8.90	22.15	164.06	Vertical	Pass
		1880	18.32	3.96	8.90	23.26	211.84	Vertical	Pass
		1900	17.75	4.00	8.90	22.65	184.08	Vertical	Pass

Note:

SG Level= Signal generator output

Max. EIRP Average (dBm)= Antenna Gain(dB)+ SG Level (dBm)- Cable Loss(dBm)

Radiated Power (EIRP) for Band 2										
Mode	RB/RB SIZE	Frequency	Result						Polarization Of Max. ERP	Conclusion
			SG Level (dBm)	Cable Loss (dBm)	Antenna Gain (dB)	Max. EIRP Average (dBm)	Max. EIRP Average (mW)			
1.4MHz Band 16 QAM	6/0	1850.7	14.60	3.76	8.90	21.36	136.77	Horizontal	Pass	
		1880	15.75	3.91	8.90	21.54	142.56	Horizontal	Pass	
		1909.3	15.45	3.93	8.90	22.31	170.22	Horizontal	Pass	
3.0MHz Band 16 QAM	15/0	1851.5	15.29	3.77	8.90	22.16	164.44	Horizontal	Pass	
		1880	14.95	3.91	8.90	21.36	136.77	Horizontal	Pass	
		1908.5	14.55	3.94	8.90	21.56	143.22	Horizontal	Pass	
5.0MHz Band 16 QAM	25/0	1852.5	15.14	3.77	8.90	21.69	147.57	Horizontal	Pass	
		1880	15.50	3.91	8.90	22.16	164.44	Horizontal	Pass	
		1907.5	14.00	3.94	8.90	21.36	136.77	Horizontal	Pass	
10.0MHz Band 16 QAM	50/0	1855	15.35	3.79	8.90	22.65	184.08	Horizontal	Pass	
		1880	14.05	3.95	8.90	22.16	164.44	Horizontal	Pass	
		1905	15.36	3.97	8.90	22.31	170.22	Horizontal	Pass	
15.0MHz Band 16 QAM	75/0	1857.5	13.68	3.79	8.90	21.26	133.66	Horizontal	Pass	
		1880	15.77	3.95	8.90	21.56	143.22	Horizontal	Pass	
		1902.5	15.65	3.97	8.90	21.03	126.77	Horizontal	Pass	
20.0MHz Band 16 QAM	100/0	1860	13.84	3.81	8.90	21.36	136.77	Horizontal	Pass	
		1880	16.17	3.96	8.90	22.31	170.22	Horizontal	Pass	
		1900	14.55	4.00	8.90	22.14	163.68	Horizontal	Pass	
1.4MHz Band 16 QAM	6/0	1850.7	14.61	3.76	8.90	21.36	136.77	Vertical	Pass	
		1880	15.84	3.91	8.90	21.45	139.64	Vertical	Pass	
		1909.3	15.13	3.93	8.90	21.36	136.77	Vertical	Pass	
3.0MHz Band 16 QAM	15/0	1851.5	13.77	3.77	8.90	23.56	226.99	Vertical	Pass	
		1880	14.83	3.91	8.90	23.12	205.12	Vertical	Pass	
		1908.5	14.56	3.94	8.90	22.13	163.31	Vertical	Pass	
5.0MHz Band 16 QAM	25/0	1852.5	13.76	3.77	8.90	22.36	172.19	Vertical	Pass	
		1880	15.05	3.91	8.90	22.16	164.44	Vertical	Pass	
		1907.5	15.69	3.94	8.90	22.31	170.22	Vertical	Pass	
10.0MHz Band 16 QAM	50/0	1855	13.98	3.79	8.90	22.15	164.06	Vertical	Pass	
		1880	15.57	3.95	8.90	22.23	167.11	Vertical	Pass	
		1905	15.12	3.97	8.90	22.16	164.44	Vertical	Pass	
15.0MHz Band 16	75/0	1857.5	13.85	3.79	8.90	22.16	164.44	Vertical	Pass	
		1880	14.87	3.95	8.90	22.36	172.19	Vertical	Pass	

QAM		1902.5	13.66	3.97	8.90	22.65	184.08	Vertical	Pass
20.0MHz	100/0	1860	14.29	3.81	8.90	21.18	131.22	Vertical	Pass
Band 16		1880	14.90	3.96	8.90	23.69	233.88	Vertical	Pass
QAM		1900	13.78	4.00	8.90	21.69	147.57	Vertical	Pass

Note:

SG Level= Signal generator output

Max. EIRP Average (dBm)= Antenna Gain(dB)+ SG Level (dBm)- Cable Loss(dBm)

8.3 LTE BAND 4

Radiated Power (EIRP) for Band 4									
Mode	RB/RB SIZE	Frequency	Result						Conclusion
			SG Level	Cable Loss	Antenna Gain	Max. EIRP	Max. EIRP	Polarization Of Max. ERP	
			(dBm)	(dBm)	(dB)	Average	Average		
					(dBm)	(mW)			
1.4MHz Band QPSK	6/0	1710.7	16.23	3.12	8.90	22.01	158.85	Horizontal	Pass
		1732.5	15.99	3.27	8.90	21.62	145.21	Horizontal	Pass
		1754.3	16.64	3.29	8.90	22.25	167.88	Horizontal	Pass
3.0MHz Band QPSK	15/0	1711.5	16.61	3.13	8.90	22.38	172.98	Horizontal	Pass
		1732.5	16.37	3.27	8.90	22.00	158.49	Horizontal	Pass
		1753.5	16.98	3.30	8.90	22.58	181.13	Horizontal	Pass
5.0MHz Band QPSK	25/0	1712.5	17.24	3.13	8.90	23.01	199.99	Horizontal	Pass
		1732.5	16.92	3.27	8.90	22.55	179.89	Horizontal	Pass
		1752.5	16.81	3.30	8.90	22.41	174.18	Horizontal	Pass
10.0MHz Band QPSK	50/0	1715	16.32	3.15	8.90	22.07	161.06	Horizontal	Pass
		1732.5	16.89	3.31	8.90	22.48	177.01	Horizontal	Pass
		1750	17.06	3.33	8.90	22.63	183.23	Horizontal	Pass
15.0MHz Band QPSK	75/0	1717.5	16.26	3.15	8.90	22.01	158.85	Horizontal	Pass
		1732.5	16.51	3.31	8.90	22.10	162.18	Horizontal	Pass
		1747.5	16.27	3.33	8.90	21.84	152.76	Horizontal	Pass
20.0MHz Band QPSK	100/0	1720	15.90	3.17	8.90	21.63	145.55	Horizontal	Pass
		1732.5	15.80	3.32	8.90	21.38	137.40	Horizontal	Pass
		1745	16.20	3.36	8.90	21.74	149.28	Horizontal	Pass
1.4MHz Band QPSK	6/0	1710.7	16.33	3.12	8.90	22.11	162.55	Vertical	Pass
		1732.5	16.36	3.27	8.90	21.99	158.12	Vertical	Pass
		1754.3	16.30	3.29	8.90	21.91	155.24	Vertical	Pass
3.0MHz Band QPSK	15/0	1711.5	16.88	3.13	8.90	22.65	184.08	Vertical	Pass
		1732.5	17.02	3.27	8.90	22.65	184.08	Vertical	Pass
		1753.5	16.91	3.30	8.90	22.51	178.24	Vertical	Pass
5.0MHz Band QPSK	25/0	1712.5	16.51	3.13	8.90	22.28	169.04	Vertical	Pass
		1732.5	16.82	3.27	8.90	22.45	175.79	Vertical	Pass
		1752.5	16.83	3.30	8.90	22.43	174.98	Vertical	Pass
10.0MHz Band QPSK	50/0	1715	16.38	3.15	8.90	22.13	163.31	Vertical	Pass
		1732.5	17.54	3.31	8.90	23.13	205.59	Vertical	Pass
		1750	17.16	3.33	8.90	22.73	187.50	Vertical	Pass

15.0MHz	75/0	1717.5	17.10	3.15	8.90	22.85	192.75	Vertical	Pass
Band		1732.5	16.48	3.31	8.90	22.07	161.06	Vertical	Pass
QPSK		1747.5	16.07	3.33	8.90	21.64	145.88	Vertical	Pass
20.0MHz	100/0	1720	17.48	3.17	8.90	23.21	209.41	Vertical	Pass
Band		1732.5	17.93	3.32	8.90	23.51	224.39	Vertical	Pass
QPSK		1745	17.34	3.36	8.90	22.88	194.089	Vertical	Pass

Note:

SG Level= Signal generator output

Max. EIRP Average (dBm)= Antenna Gain(dB)+ SG Level (dBm)- Cable Loss(dBm)

Radiated Power (EIRP) for Band 4										
Mode	RB/RB SIZE	Frequency	Result						Polarization Of Max. ERP	Conclusion
			SG Level	Cable Loss	Antenna Gain	Max. EIRP	Max. EIRP			
			(dBm)	(dBm)	(dB)	Average	Average			
						(dBm)	(mW)			
1.4MHz Band 16 QAM	6/0	1710.7	13.99	3.12	8.90	22.70	186.21	Horizontal	Pass	
		1732.5	13.82	3.27	8.90	22.43	174.98	Horizontal	Pass	
		1754.3	13.98	3.29	8.90	22.12	162.93	Horizontal	Pass	
3.0MHz Band 16 QAM	15/0	1711.5	13.99	3.13	8.90	22.03	159.59	Horizontal	Pass	
		1732.5	13.10	3.27	8.90	23.12	205.12	Horizontal	Pass	
		1753.5	14.43	3.30	8.90	23.16	207.01	Horizontal	Pass	
5.0MHz Band 16 QAM	25/0	1712.5	13.46	3.13	8.90	23.13	205.59	Horizontal	Pass	
		1732.5	14.39	3.27	8.90	22.19	165.58	Horizontal	Pass	
		1752.5	13.10	3.30	8.90	22.41	174.18	Horizontal	Pass	
10.0MHz Band 16 QAM	50/0	1715	13.46	3.15	8.90	23.13	205.59	Horizontal	Pass	
		1732.5	13.99	3.31	8.90	22.16	164.44	Horizontal	Pass	
		1750	14.35	3.33	8.90	21.45	139.64	Horizontal	Pass	
15.0MHz Band 16 QAM	75/0	1717.5	13.89	3.15	8.90	23.10	204.17	Horizontal	Pass	
		1732.5	13.77	3.31	8.90	22.13	163.31	Horizontal	Pass	
		1747.5	14.71	3.33	8.90	21.56	143.22	Horizontal	Pass	
20.0MHz Band 16 QAM	100/0	1720	13.03	3.17	8.90	23.32	214.78	Horizontal	Pass	
		1732.5	13.28	3.32	8.90	23.11	204.64	Horizontal	Pass	
		1745	14.01	3.36	8.90	22.81	190.99	Horizontal	Pass	
1.4MHz Band 16 QAM	6/0	1710.7	14.23	3.12	8.90	23.12	205.12	Vertical	Pass	
		1732.5	14.13	3.27	8.90	23.45	221.31	Vertical	Pass	
		1754.3	14.44	3.29	8.90	22.52	178.65	Vertical	Pass	
3.0MHz Band 16 QAM	15/0	1711.5	13.33	3.13	8.90	22.13	163.31	Vertical	Pass	
		1732.5	14.14	3.27	8.90	22.76	188.80	Vertical	Pass	
		1753.5	13.07	3.30	8.90	23.24	210.86	Vertical	Pass	
5.0MHz Band 16 QAM	25/0	1712.5	13.11	3.13	8.90	23.22	209.89	Vertical	Pass	
		1732.5	14.12	3.27	8.90	22.22	166.72	Vertical	Pass	
		1752.5	13.15	3.30	8.90	22.26	168.27	Vertical	Pass	
10.0MHz Band 16 QAM	50/0	1715	13.98	3.15	8.90	22.69	185.78	Vertical	Pass	
		1732.5	14.72	3.31	8.90	23.04	201.37	Vertical	Pass	
		1750	13.70	3.33	8.90	22.25	167.88	Vertical	Pass	
15.0MHz Band 16	75/0	1717.5	14.58	3.15	8.90	23.46	221.82	Vertical	Pass	
		1732.5	14.42	3.31	8.90	23.43	220.29	Vertical	Pass	

QAM		1747.5	13.45	3.33	8.90	23.10	204.17	Vertical	Pass
20.0MHz	100/0	1720	12.78	3.17	8.90	22.76	188.80	Vertical	Pass
Band 16		1732.5	14.84	3.32	8.90	23.53	225.42	Vertical	Pass
QAM		1745	12.81	3.36	8.90	23.13	205.589	Vertical	Pass

Note:

SG Level= Signal generator output

Max. EIRP Average (dBm)= Antenna Gain(dB)+ SG Level (dBm)- Cable Loss(dBm)

8.4 LTE BAND 5

Radiated Power (ERP) for Band 5											
Mode	RB/RB SIZE	Frequency	Result							Polarization Of Max. ERP	Conclusion
			SG Level	Cable Loss (dBm)	Antenna Gain (dB)	Correction (dB)	Max. EIRP	Max. EIRP			
			(dBm)				Average	Average			
							(dBm)	(mW)			
1.4MHz Band QPSK	6/0	824.7	21.01	2.01	5.30	2.15	22.15	164.06	Horizontal	Pass	
		836.5	21.56	2.01	5.30	2.15	22.70	186.21	Horizontal	Pass	
		848.3	22.18	2.02	5.70	2.15	23.71	234.96	Horizontal	Pass	
3.0MHz Band QPSK	15/0	825.5	21.95	2.01	5.30	2.15	23.09	203.70	Horizontal	Pass	
		836.5	21.71	2.01	5.30	2.15	22.85	192.75	Horizontal	Pass	
		847.5	22.07	2.02	5.70	2.15	23.60	229.09	Horizontal	Pass	
5.0MHz Band QPSK	25/0	826.5	22.01	2.01	5.30	2.15	23.15	206.54	Horizontal	Pass	
		836.5	21.17	2.01	5.30	2.15	22.31	170.22	Horizontal	Pass	
		846.5	22.02	2.02	5.70	2.15	23.55	226.46	Horizontal	Pass	
10.0MHz Band QPSK	50/0	829	22.70	2.01	5.30	2.15	23.84	242.10	Horizontal	Pass	
		836.5	21.93	2.01	5.30	2.15	23.07	202.77	Horizontal	Pass	
		844	21.47	2.02	5.70	2.15	23.00	199.53	Horizontal	Pass	
1.4MHz Band QPSK	6/0	824.7	22.64	2.01	5.30	2.15	23.78	238.78	Vertical	Pass	
		836.5	22.70	2.01	5.30	2.15	23.84	242.10	Vertical	Pass	
		848.3	22.06	2.02	5.70	2.15	23.59	228.56	Vertical	Pass	
3.0MHz Band QPSK	15/0	825.5	22.36	2.01	5.30	2.15	23.50	223.87	Vertical	Pass	
		836.5	22.60	2.01	5.30	2.15	23.74	236.59	Vertical	Pass	
		847.5	22.15	2.02	5.70	2.15	23.68	233.35	Vertical	Pass	
5.0MHz Band QPSK	25/0	826.5	21.98	2.01	5.30	2.15	23.12	205.12	Vertical	Pass	
		836.5	22.55	2.01	5.30	2.15	23.69	233.88	Vertical	Pass	
		846.5	21.84	2.02	5.70	2.15	23.37	217.27	Vertical	Pass	
10.0MHz Band QPSK	50/0	829	21.89	2.01	5.30	2.15	23.03	200.91	Vertical	Pass	
		836.5	22.77	2.01	5.30	2.15	23.91	246.04	Vertical	Pass	
		844	22.00	2.02	5.70	2.15	23.53	225.42	Vertical	Pass	

Radiated Power (ERP) for Band 5											
Mode	RB/RB SIZE	Frequency	Result							Polarization Of Max. ERP	Conclusion
			SG Level	Cable Loss (dBm)	Antenna Gain (dB)	Correction (dB)	Max. EIRP	Max. EIRP			
			(dBm)				Average	Average			
							(dBm)	(mW)			
1.4MHz Band 16 QAM	6/0	824.7	21.63	2.01	5.30	2.15	22.77	189.23	Horizontal	Pass	
		836.5	20.86	2.01	5.30	2.15	22.00	158.49	Horizontal	Pass	
		848.3	20.57	2.02	5.70	2.15	22.10	162.18	Horizontal	Pass	
3.0MHz Band 16 QAM	15/0	825.5	20.90	2.01	5.30	2.15	22.04	159.96	Horizontal	Pass	
		836.5	20.85	2.01	5.30	2.15	21.99	158.12	Horizontal	Pass	
		847.5	20.67	2.02	5.70	2.15	22.20	165.96	Horizontal	Pass	
5.0MHz Band 16 QAM	25/0	826.5	20.67	2.01	5.30	2.15	21.81	151.71	Horizontal	Pass	
		836.5	20.81	2.01	5.30	2.15	21.95	156.68	Horizontal	Pass	
		846.5	20.95	2.02	5.70	2.15	22.48	177.01	Horizontal	Pass	
10.0MHz Band 16 QAM	50/0	829	20.91	2.01	5.30	2.15	22.05	160.32	Horizontal	Pass	
		836.5	20.83	2.01	5.30	2.15	21.97	157.40	Horizontal	Pass	
		844	21.36	2.02	5.70	2.15	22.89	194.54	Horizontal	Pass	
1.4MHz Band 16 QAM	6/0	824.7	21.59	2.01	5.30	2.15	22.73	187.50	Vertical	Pass	
		836.5	21.85	2.01	5.30	2.15	22.99	199.07	Vertical	Pass	
		848.3	21.13	2.02	5.70	2.15	22.66	184.50	Vertical	Pass	
3.0MHz Band 16 QAM	15/0	825.5	21.18	2.01	5.30	2.15	22.32	170.61	Vertical	Pass	
		836.5	20.89	2.01	5.30	2.15	22.03	159.59	Vertical	Pass	
		847.5	21.31	2.02	5.70	2.15	22.84	192.31	Vertical	Pass	
5.0MHz Band 16 QAM	25/0	826.5	21.67	2.01	5.30	2.15	22.81	190.99	Vertical	Pass	
		836.5	20.81	2.01	5.30	2.15	21.95	156.68	Vertical	Pass	
		846.5	21.25	2.02	5.70	2.15	22.78	189.67	Vertical	Pass	
10.0MHz Band 16 QAM	50/0	829	21.43	2.01	5.30	2.15	22.57	180.72	Vertical	Pass	
		836.5	21.46	2.01	5.30	2.15	22.60	181.97	Vertical	Pass	
		844	21.73	2.02	5.70	2.15	23.26	211.84	Vertical	Pass	

Note:

ERP=EIRP-2.15

SG Level= Signal generator output

Max. EIRP Average (dBm)= Antenna Gain(dB)+ SG Level (dBm)- Cable Loss(dBm)

8.5 LTE BAND 7

Radiated Power (EIRP) for Band 7									
Mode	RB/RB SIZE	Frequency	Result						Conclusion
			SG Level	Cable Loss	Antenna Gain	Max. EIRP	Max. EIRP	Polarization	
			(dBm)	(dBm)	(dB)	Average	Average	Of Max. ERP	
						(dBm)	(mW)		
5.0MHz Band QPSK	25/0	2502.5	18.64	4.54	9.00	23.10	204.17	Horizontal	Pass
		2535	18.23	4.69	9.00	22.54	179.47	Horizontal	Pass
		2567.5	17.22	4.71	9.00	21.51	141.58	Horizontal	Pass
10.0MHz Band QPSK	50/0	2505	18.15	4.55	9.00	22.60	181.97	Horizontal	Pass
		2535	17.95	4.69	9.00	22.26	168.27	Horizontal	Pass
		2565	18.97	4.72	9.00	23.25	211.35	Horizontal	Pass
15.0MHz Band QPSK	75/0	2507.5	18.71	4.55	9.00	23.16	207.01	Horizontal	Pass
		2535	17.80	4.69	9.00	22.11	162.55	Horizontal	Pass
		2562.5	17.90	4.72	9.00	22.18	165.20	Horizontal	Pass
20.0MHz Band QPSK	100/0	2510	17.94	4.57	9.00	22.37	172.58	Horizontal	Pass
		2535	18.06	4.73	9.00	22.33	171.00	Horizontal	Pass
		2560	17.39	4.75	9.00	21.64	145.88	Horizontal	Pass
5.0MHz Band QPSK	25/0	2502.5	17.32	4.54	9.00	21.78	150.66	Vertical	Pass
		2535	18.83	4.69	9.00	23.14	206.06	Vertical	Pass
		2567.5	18.07	4.71	9.00	22.36	172.19	Vertical	Pass
10.0MHz Band QPSK	50/0	2505	17.98	4.55	9.00	22.43	174.98	Vertical	Pass
		2535	17.81	4.69	9.00	22.12	162.93	Vertical	Pass
		2565	18.33	4.72	9.00	22.61	182.39	Vertical	Pass
15.0MHz Band QPSK	75/0	2507.5	18.91	4.55	9.00	23.36	216.77	Vertical	Pass
		2535	18.22	4.69	9.00	22.53	179.06	Vertical	Pass
		2562.5	19.48	4.72	9.00	23.76	237.68	Vertical	Pass
20.0MHz Band QPSK	100/0	2510	19.36	4.57	9.00	23.79	239.33	Vertical	Pass
		2535	19.25	4.73	9.00	23.52	224.91	Vertical	Pass
		2560	19.03	4.75	9.00	23.28	212.81	Vertical	Pass

Radiated Power (EIRP) for Band 7										
Mode	RB/RB SIZE	Frequency	Result						Polarization Of Max. ERP	Conclusion
			SG Level (dBm)	Cable Loss (dBm)	Antenna Gain (dB)	Max. EIRP Average (dBm)	Max. EIRP Average (mW)			
5.0MHz Band 16 QAM	25/0	2502.5	16.97	4.54	9.00	21.43	139.00	Horizontal	Pass	
		2535	17.21	4.69	9.00	21.52	141.91	Horizontal	Pass	
		2567.5	17.84	4.71	9.00	22.13	163.31	Horizontal	Pass	
10.0MHz Band 16 QAM	50/0	2505	17.71	4.55	9.00	22.16	164.44	Horizontal	Pass	
		2535	18.72	4.69	9.00	23.03	200.91	Horizontal	Pass	
		2565	19.30	4.72	9.00	23.58	228.03	Horizontal	Pass	
15.0MHz Band 16 QAM	75/0	2507.5	18.14	4.55	9.00	22.59	181.55	Horizontal	Pass	
		2535	18.28	4.69	9.00	22.59	181.55	Horizontal	Pass	
		2562.5	17.89	4.72	9.00	22.17	164.82	Horizontal	Pass	
20.0MHz Band 16 QAM	100/0	2510	17.94	4.57	9.00	22.37	172.58	Horizontal	Pass	
		2535	17.07	4.73	9.00	21.34	136.14	Horizontal	Pass	
		2560	18.53	4.75	9.00	22.78	189.67	Horizontal	Pass	
5.0MHz Band 16 QAM	25/0	2502.5	17.70	4.54	9.00	22.16	164.44	Vertical	Pass	
		2535	17.45	4.69	9.00	21.76	149.97	Vertical	Pass	
		2567.5	17.10	4.71	9.00	21.39	137.72	Vertical	Pass	
10.0MHz Band 16 QAM	50/0	2505	17.68	4.55	9.00	22.13	163.31	Vertical	Pass	
		2535	17.81	4.69	9.00	22.12	162.93	Vertical	Pass	
		2565	17.78	4.72	9.00	22.06	160.69	Vertical	Pass	
15.0MHz Band 16 QAM	75/0	2507.5	18.62	4.55	9.00	23.07	202.77	Vertical	Pass	
		2535	17.83	4.69	9.00	22.14	163.68	Vertical	Pass	
		2562.5	18.50	4.72	9.00	22.78	189.67	Vertical	Pass	
20.0MHz Band 16 QAM	100/0	2510	18.73	4.57	9.00	23.16	207.01	Vertical	Pass	
		2535	19.55	4.73	9.00	23.82	240.99	Vertical	Pass	
		2560	19.21	4.75	9.00	23.46	221.82	Vertical	Pass	

Note:

SG Level= Signal generator output

Max. EIRP Average (dBm)= Antenna Gain(dB)+ SG Level (dBm)- Cable Loss(dBm)

8.6 LTE BAND66

Radiated Power (EIRP) for Band 66									
Mode	RB/RB SIZE	Frequency	Result						Conclusion
			SG Level (dBm)	Cable Loss (dBm)	Antenna Gain (dB)	Max. EIRP	Max. EIRP	Polarization Of Max. ERP	
						Average (dBm)	Average		
1.4MHz Band QPSK	6/0	1710.7	17.20	3.12	8.9	22.98	198.61	Horizontal	Pass
		1745	17.04	3.27	8.9	22.67	184.93	Horizontal	Pass
		1779.3	17.61	3.29	8.9	23.22	209.89	Horizontal	Pass
3.0MHz Band QPSK	15/0	1711.5	17.58	3.13	8.9	23.35	216.27	Horizontal	Pass
		1745	17.34	3.27	8.9	22.97	198.15	Horizontal	Pass
		1778.5	17.95	3.3	8.9	23.55	226.46	Horizontal	Pass
5.0MHz Band QPSK	25/0	1712.5	17.35	3.13	8.9	23.12	205.12	Horizontal	Pass
		1745	17.89	3.27	8.9	23.52	224.91	Horizontal	Pass
		1777.5	17.78	3.3	8.9	23.38	217.77	Horizontal	Pass
10.0MHz Band QPSK	50/0	1715	17.29	3.15	8.9	23.04	201.37	Horizontal	Pass
		1745	17.86	3.31	8.9	23.45	221.31	Horizontal	Pass
		1775	18.04	3.33	8.9	23.61	229.61	Horizontal	Pass
15.0MHz Band QPSK	75/0	1717.5	16.77	3.15	8.9	22.52	178.65	Horizontal	Pass
		1745	17.48	3.31	8.9	23.07	202.77	Horizontal	Pass
		1772.5	17.24	3.33	8.9	22.81	190.99	Horizontal	Pass
20.0MHz Band QPSK	100/0	1720	16.43	3.17	8.9	22.16	164.44	Horizontal	Pass
		1745	16.77	3.32	8.9	22.35	171.79	Horizontal	Pass
		1770	17.17	3.36	8.9	22.71	186.64	Horizontal	Pass
1.4MHz Band QPSK	6/0	1710.7	17.30	3.12	8.9	23.08	203.24	Vertical	Pass
		1745	17.33	3.27	8.9	22.96	197.70	Vertical	Pass
		1779.3	17.27	3.29	8.9	22.88	194.09	Vertical	Pass
3.0MHz Band QPSK	15/0	1711.5	16.86	3.13	8.9	22.63	183.23	Vertical	Pass
		1745	17.02	3.27	8.9	22.65	184.08	Vertical	Pass
		1778.5	17.88	3.3	8.9	23.48	222.84	Vertical	Pass
5.0MHz Band QPSK	25/0	1712.5	17.48	3.13	8.9	23.25	211.35	Vertical	Pass
		1745	17.84	3.27	8.9	23.47	222.33	Vertical	Pass
		1777.5	17.81	3.3	8.9	23.41	219.28	Vertical	Pass
10.0MHz Band	50/0	1715	17.38	3.15	8.9	23.13	205.59	Vertical	Pass
		1745	17.04	3.31	8.9	22.63	183.23	Vertical	Pass

QPSK		1775	17.46	3.33	8.9	23.03	200.91	Vertical	Pass
15.0MHz	75/0	1717.5	16.86	3.15	8.9	22.61	182.39	Vertical	Pass
Band		1745	17.45	3.31	8.9	23.04	201.37	Vertical	Pass
QPSK		1772.5	17.04	3.33	8.9	22.61	182.39	Vertical	Pass
20.0MHz	100/0	1720	18.23	3.17	8.9	23.96	248.89	Vertical	Pass
Band		1745	16.27	3.32	8.9	21.85	153.11	Vertical	Pass
QPSK		1770	18.31	3.36	8.9	23.85	242.66	Vertical	Pass

Radiated Power (EIRP) for Band 66										
Mode	RB/RB SIZE	Frequency	Result						Polarization Of Max. ERP	Conclusion
			SG Level (dBm)	Cable Loss (dBm)	Antenna Gain (dB)	Max. EIRP Average (dBm)	Max. EIRP Average (mW)			
1.4MHz Band 16 QAM	6/0	1710.7	16.79	3.12	8.9	22.57	180.72	Horizontal	Pass	
		1745	17.64	3.27	8.9	23.27	212.32	Horizontal	Pass	
		1779.3	17.38	3.29	8.9	22.99	199.07	Horizontal	Pass	
3.0MHz Band 16 QAM	15/0	1711.5	17.06	3.13	8.9	22.83	191.87	Horizontal	Pass	
		1745	16.98	3.27	8.9	22.61	182.39	Horizontal	Pass	
		1778.5	17.49	3.3	8.9	23.09	203.70	Horizontal	Pass	
5.0MHz Band 16 QAM	25/0	1712.5	17.30	3.13	8.9	23.07	202.77	Horizontal	Pass	
		1745	17.77	3.27	8.9	23.4	218.78	Horizontal	Pass	
		1777.5	17.59	3.3	8.9	23.19	208.45	Horizontal	Pass	
10.0MHz Band 16 QAM	50/0	1715	17.20	3.15	8.9	22.95	197.24	Horizontal	Pass	
		1745	17.23	3.31	8.9	22.82	191.43	Horizontal	Pass	
		1775	17.26	3.33	8.9	22.83	191.87	Horizontal	Pass	
15.0MHz Band 16 QAM	75/0	1717.5	16.77	3.15	8.9	22.52	178.65	Horizontal	Pass	
		1745	17.29	3.31	8.9	22.88	194.09	Horizontal	Pass	
		1772.5	17.03	3.33	8.9	22.6	181.97	Horizontal	Pass	
20.0MHz Band 16 QAM	100/0	1720	17.79	3.17	8.9	23.52	224.91	Horizontal	Pass	
		1745	17.43	3.32	8.9	23.01	199.99	Horizontal	Pass	
		1770	17.23	3.36	8.9	22.77	189.23	Horizontal	Pass	
1.4MHz Band 16 QAM	6/0	1710.7	17.21	3.12	8.9	22.99	199.07	Vertical	Pass	
		1745	17.39	3.27	8.9	23.02	200.45	Vertical	Pass	
		1779.3	17.82	3.29	8.9	23.43	220.29	Vertical	Pass	
3.0MHz Band 16 QAM	15/0	1711.5	17.44	3.13	8.9	23.21	209.41	Vertical	Pass	
		1745	17.52	3.27	8.9	23.15	206.54	Vertical	Pass	
		1778.5	17.24	3.3	8.9	22.84	192.31	Vertical	Pass	
5.0MHz Band 16 QAM	25/0	1712.5	17.12	3.13	8.9	22.89	194.54	Vertical	Pass	
		1745	17.49	3.27	8.9	23.12	205.12	Vertical	Pass	
		1777.5	17.86	3.3	8.9	23.46	221.82	Vertical	Pass	
10.0MHz Band 16 QAM	50/0	1715	16.66	3.15	8.9	22.41	174.18	Vertical	Pass	
		1745	17.80	3.31	8.9	23.39	218.27	Vertical	Pass	
		1775	16.74	3.33	8.9	22.31	170.22	Vertical	Pass	
15.0MHz Band 16	75/0	1717.5	16.97	3.15	8.9	22.72	187.07	Vertical	Pass	
		1745	16.89	3.31	8.9	22.48	177.01	Vertical	Pass	

QAM		1772.5	16.93	3.33	8.9	22.5	177.83	Vertical	Pass
20.0MHz	100/0	1720	17.55	3.17	8.9	23.28	212.81	Vertical	Pass
Band 16		1745	17.95	3.32	8.9	23.53	225.42	Vertical	Pass
QAM		1770	17.80	3.36	8.9	23.34	215.77	Vertical	Pass

Note:

SG Level= Signal generator output

Max. EIRP Average (dBm)= Antenna Gain(dB)+ SG Level (dBm)- Cable Loss(dBm)

9. SPURIOUS RADIATION EMISSION

RULE PART(S)

FCC: §2.1051, §22.917(a), §24.238(a), §27.53(c)(g)(h)(m)

LIMIT

For Band 7, the minimum permissible attenuation level of any spurious emission is $55 + \log_{10}(P)$ [Watts].

The minimum permissible attenuation level of any spurious emission is $43 + \log_{10}(P)$ [Watts], where P is the transmitter power in Watts.

TEST PROCEDURE

For Cellular equipment - Compliance with these rules is based on the use of measurement instrumentation employing a resolution bandwidth of 100 kHz or greater. In the 1 MHz bands immediately outside and adjacent to the frequency block a resolution bandwidth of at least one percent of the emission bandwidth of the fundamental emission of the transmitter may be employed. A narrower resolution bandwidth is permitted in all cases to improve measurement accuracy provided the measured power is integrated over the full required measurement bandwidth (i.e. 100 kHz or 1 percent of emission bandwidth, as specified). The emission bandwidth is defined as the width of the signal between two points, one below the carrier center frequency and one above the carrier center frequency, outside of which all emissions are attenuated at least 26 dB below the transmitter power.

For PCS equipment - Compliance with these rules is based on the use of measurement instrumentation employing a resolution bandwidth of 1 MHz or greater. However, in the 1 MHz bands immediately outside and adjacent to the frequency block a resolution bandwidth of at least one percent of the emission bandwidth of the fundamental emission of the transmitter may be employed. A narrower resolution bandwidth is permitted in all cases to improve measurement accuracy provided the measured power is integrated over the full required measurement bandwidth (i.e. 1 MHz or 1 percent of emission bandwidth, as specified). The emission bandwidth is defined as the width of the signal between two points, one below the carrier center frequency and one above the carrier center frequency, outside of which all emissions are attenuated at least 26 dB below the transmitter power.

The unwanted emission power shall be measured with a resolution bandwidth of at least 1% of the occupied bandwidth in the 1 MHz band immediately outside and adjacent to the channel edge of the equipment. Beyond the 1 MHz band immediately outside the channel edge of the equipment, a resolution bandwidth of 1 MHz shall be employed. A narrower resolution bandwidth is allowed to be used provided that the measured power is integrated over the full required measurement bandwidth of 1 MHz or 1% of the occupied bandwidth as applicable.

The power of any unwanted emissions measured from the channel edge of the equipment shall be attenuated below the transmitter power, P (dBW), as follows:

- a. for base station and subscriber equipment, other than mobile subscriber equipment, the attenuation shall not be less than $43 + 10 \text{ Log}_{10} (p)$, dB; and
- b. for mobile subscriber equipment, the attenuation shall not be less than $43 + 10 \text{ Log}_{10} (p)$, dB at the channel edges and $55 + 10 \text{ Log}_{10} (p)$ at 5.5 MHz away and beyond the channel edges where p in (a) and (b) is the transmitter power measured in watts.

MODES TESTED

- LTE Band2
LTE Band 4
- LTE Band 5
LTE Band 7
LTE Band 66

RESULTS

PASS

9.1 LTE BAND 2

QPSK EIRP POWER FOR LTE BAND 2 (1.4MHZ BANDWIDTH)

Test Results for Low Channel 1850.7MHz							
Frequency (MHz)	Spectrum Analyzer (dBm)	Cable Loss (dB)	Antenna Factor (dB/m)	Spurious Emission Level (dBm)	Limit (dBm)	Margin(dBm)	Polarity
3701.4	-49.02	4.04	33.51	-19.55	-13	-6.55	Horizontal
3701.4	-48.33	4.04	33.51	-18.86	-13	-5.86	Vertical
5552.1	-52.71	5.24	35.84	-22.11	-13	-9.11	Vertical
5552.1	-63.82	5.24	35.84	-33.22	-13	-20.22	Horizontal
Test Results for Mid Channel 1880MHz							
3760	-49.14	4.04	33.56	-19.62	-13	-6.62	Horizontal
3760	-50.92	4.04	33.56	-21.40	-13	-8.40	Vertical
5640	-48.53	5.24	35.91	-17.86	-13	-4.86	Vertical
5640	-49.21	5.24	35.91	-18.54	-13	-5.54	Horizontal
Test Results for High Channel 1909.3MHz							
3818.6	-49.67	4.04	34.00	-19.71	-13	-6.71	Horizontal
3818.6	-50.36	4.04	34.00	-20.40	-13	-7.40	Vertical
5727.9	-54.61	5.24	36.04	-23.81	-13	-10.81	Vertical
5727.9	-51.25	5.24	36.04	-20.45	-13	-7.45	Horizontal

QPSK EIRP POWER FOR LTE BAND 2 (20.0MHZ BANDWIDTH)

Test Results for Low Channel 1860MHz							
Frequency (MHz)	Spectrum Analyzer (dBm)	Cable Loss (dB)	Antenna Factor (dB/m)	Spurious Emission Level (dBm)	Limit (dBm)	Margin(dBm)	Polarity
3720	-51.95	4.07	33.54	-22.48	-13	-9.48	Horizontal
3720	-46.68	4.07	33.54	-17.21	-13	-4.21	Vertical
5580	-53.24	5.28	35.86	-22.66	-13	-9.66	Vertical
5580	-56.37	5.28	35.86	-25.79	-13	-12.79	Horizontal
Test Results for Mid Channel 1880MHz							
3760	-51.62	4.04	33.56	-22.10	-13	-9.10	Horizontal
3760	-47.01	4.04	33.56	-17.49	-13	-4.49	Vertical
5640	-51.77	5.24	35.91	-21.10	-13	-8.10	Vertical
5640	-52.86	5.24	35.91	-22.19	-13	-9.19	Horizontal
Test Results for High Channel 1900MHz							
3800	-49.62	4.04	34.00	-19.66	-13	-6.66	Horizontal
3800	-51.45	4.04	34.00	-21.49	-13	-8.49	Vertical
5700	-52.09	5.24	36.04	-21.29	-13	-8.29	Vertical
5700	-52.89	5.24	36.04	-22.09	-13	-9.09	Horizontal

Note:

1. We were tested all Configuration refer 3GPP TS134 121.
2. Spurious Emission Level = Spectrum Analyzer Read Value + Cable Loss+ Antenna Factor + 11.74
3. Margin = Spurious Emission Level - Limit
4. Both QPSK and 16QAM has been tested, the worst case is QPSK mode, the report just reported the worst case.

9.2 LTE BAND 4

QPSK EIRP POWER FOR LTE BAND 4 (1.4MHZ BANDWIDTH)

Test Results for Low Channel 1710.7MHz							
Frequency (MHz)	Spectrum Analyzer (dBm)	Cable Loss (dB)	Antenna Factor (dB/m)	Spurious Emission Level (dBm)	Limit (dBm)	Margin(dBm)	Polarity
3421.4	-53.50	4.02	29.80	-27.72	-13	-14.72	Horizontal
3421.4	-52.44	4.02	29.80	-26.66	-13	-13.66	Vertical
5132.1	-55.69	5.24	35.84	-25.09	-13	-12.09	Vertical
5132.1	-58.70	5.24	35.84	-28.10	-13	-15.10	Horizontal
Test Results for Mid Channel 1732.5MHz							
3465	-45.61	4.03	30.00	-19.64	-13	-6.64	Horizontal
3465	-49.38	4.03	30.00	-23.41	-13	-10.41	Vertical
5197.5	-51.97	5.25	35.86	-21.36	-13	-8.36	Vertical
5197.5	-51.25	5.25	35.86	-20.64	-13	-7.64	Horizontal
Test Results for High Channel 1754.3MHz							
3508.6	-46.93	4.05	30.01	-20.97	-13	-7.97	Horizontal
3508.6	-54.11	4.05	30.01	-28.15	-13	-15.15	Vertical
5262.9	-53.54	5.26	35.86	-22.94	-13	-9.94	Vertical
5262.9	-49.54	5.26	35.86	-18.94	-13	-5.94	Horizontal

QPSK EIRP POWER FOR LTE BAND 4 (20.0MHZ BANDWIDTH)

Test Results for Low Channel 1720MHz							
Frequency (MHz)	Spectrum Analyzer (dBm)	Cable Loss (dB)	Antenna Factor (dB/m)	Spurious Emission Level (dBm)	Limit (dBm)	Margin(dBm)	Polarity
3440	-52.54	4.02	29.80	-26.76	-13	-13.76	Horizontal
3440	-53.58	4.02	29.80	-27.80	-13	-14.80	Vertical
5160	-54.28	5.24	35.84	-23.68	-13	-10.68	Vertical
5160	-57.99	5.24	35.84	-27.39	-13	-14.39	Horizontal
Test Results for Mid Channel 1732.5MHz							
3465	-44.27	4.03	30.00	-18.30	-13	-5.30	Horizontal
3465	-50.38	4.03	30.00	-24.41	-13	-11.41	Vertical
5197.5	-55.94	5.25	35.86	-25.33	-13	-12.33	Vertical
5197.5	-52.89	5.25	35.86	-22.28	-13	-9.28	Horizontal
Test Results for High Channel 1745MHz							
2490	-49.11	2.91	27.68	-24.34	-13	-11.34	Horizontal
3490	-51.57	2.91	27.68	-26.80	-13	-13.80	Vertical
5235	-53.76	5.26	35.86	-23.16	-13	-10.16	Vertical
5235	-52.21	5.26	35.86	-21.61	-13	-8.61	Horizontal

Note:

1. We were tested all Configuration refer 3GPP TS134 121.
2. Spurious Emission Level = Spectrum Analyzer Read Value + Cable Loss+ Antenna Factor + 11.74
3. Margin = Spurious Emission Level - Limit
4. Both QPSK and 16QAM has been tested, the worst case is QPSK mode, the report just reported the worst case.

9.3 LTE BAND 5

QPSK EIRP POWER FOR LTE BAND 5 (1.4MHZ BANDWIDTH)

Test Results for Low Channel 824.7MHz							
Frequency (MHz)	Spectrum Analyzer (dBm)	Cable Loss (dB)	Antenna Factor (dB/m)	Spurious Emission Level (dBm)	Limit (dBm)	Margin(dBm)	Polarity
1649.4	-51.74	2.78	27.43	-27.09	-13	-14.09	Horizontal
1649.4	-53.22	2.78	27.43	-28.57	-13	-15.57	Vertical
2474.1	-49.23	2.92	27.74	-24.41	-13	-11.41	Vertical
2474.1	-51.34	2.92	27.74	-26.52	-13	-13.52	Horizontal
Test Results For Mid Channel 836.5MHz							
1673	-50.75	2.78	27.48	-26.05	-13	-13.05	Horizontal
1673	-49.03	2.78	27.48	-24.33	-13	-11.33	Vertical
2509.5	-51.24	2.91	27.70	-26.45	-13	-13.45	Vertical
2509.5	-51.73	2.91	27.70	-26.94	-13	-13.94	Horizontal
Test Results for High Channel 848.3MHz							
1696.6	-51.74	2.78	27.43	-27.09	-13	-14.09	Horizontal
1696.6	-53.22	2.78	27.43	-28.57	-13	-15.57	Vertical
2544.9	-49.23	2.92	27.74	-24.41	-13	-11.41	Vertical
2544.9	-51.34	2.92	27.74	-26.52	-13	-13.52	Horizontal

QPSK EIRP POWER FOR LTE BAND 5 (10MHZ BANDWIDTH)

Test Results for Low Channel 829MHz							
Frequency (MHz)	Spectrum Analyzer (dBm)	Cable Loss (dB)	Antenna Factor (dB/m)	Spurious Emission Level (dBm)	Limit (dBm)	Margin(dBm)	Polarity
1658	-48.78	2.78	27.50	-24.06	-13	-11.06	Horizontal
1658	-45.64	2.78	27.50	-20.92	-13	-7.92	Vertical
2487	-51.65	2.90	27.80	-26.75	-13	-13.75	Vertical
2487	-49.53	2.90	27.80	-24.63	-13	-11.63	Horizontal
Test Results for Mid Channel 836.5MHz							
1673	-48.88	2.78	27.48	-24.18	-13	-11.18	Horizontal
1673	-46.95	2.78	27.48	-22.25	-13	-9.25	Vertical
2509.5	-51.38	2.91	27.70	-26.59	-13	-13.59	Vertical
2509.5	-48.09	2.91	27.70	-23.30	-13	-10.30	Horizontal
Test Results for High Channel 844MHz							
1688	-51.69	2.78	27.43	-27.04	-13	-14.04	Horizontal
1688	-45.21	2.78	27.43	-20.56	-13	-7.56	Vertical
2532	-46.60	2.92	27.74	-21.78	-13	-8.78	Vertical
2532	-46.36	2.92	27.74	-21.54	-13	-8.54	Horizontal

Note:

1. We were tested all Configuration refer 3GPP TS134 121.
2. Spurious Emission Level = Spectrum Analyzer Read Value + Cable Loss+ Antenna Factor + 11.74
3. Margin = Spurious Emission Level - Limit
4. Both QPSK and 16QAM has been tested, the worst case is QPSK mode, the report just reported the worst case.

9.4 LTE BAND 7

QPSK EIRP POWER FOR LTE BAND 7 (5.0MHZ BANDWIDTH)

Test Results for Low Channel 2502.5MHz							
Frequency (MHz)	Spectrum Analyzer (dBm)	Cable Loss (dB)	Antenna Factor (dB/m)	Spurious Emission Level (dBm)	Limit (dBm)	Margin(dBm)	Polarity
5005	-62.74	5.23	35.81	-32.16	-25	-7.16	Horizontal
5005	-61.75	5.23	35.81	-31.17	-25	-6.17	Vertical
7507.5	-66.28	5.67	36.85	-35.10	-25	-10.10	Vertical
7507.5	-62.86	5.67	36.85	-31.68	-25	-6.68	Horizontal
Test Results for Mid Channel 2535MHz							
5070	-59.99	5.23	35.82	-29.40	-25	-4.40	Horizontal
5070	-63.12	5.23	35.82	-32.53	-25	-7.53	Vertical
7605	-64.46	5.67	36.85	-33.28	-25	-8.28	Vertical
7605	-64.85	5.67	36.85	-33.67	-25	-8.67	Horizontal
Test Results for High Channel 2567.5MHz							
5135	-64.66	5.24	35.83	-34.07	-25	-9.07	Horizontal
5135	-61.92	5.24	35.83	-31.33	-25	-6.33	Vertical
7702.5	-64.43	5.68	36.87	-33.24	-25	-8.24	Vertical
7702.5	-63.83	5.68	36.87	-32.64	-25	-7.64	Horizontal

QPSK EIRP POWER FOR LTE BAND 7 (20.0MHZ BANDWIDTH)

Test Results for Low Channel 2510MHz							
Frequency (MHz)	Spectrum Analyzer (dBm)	Cable Loss (dB)	Antenna Factor (dB/m)	Spurious Emission Level (dBm)	Limit (dBm)	Margin(dBm)	Polarity
5020	-63.71	5.23	35.82	-33.12	-25	-8.12	Horizontal
5020	-61.44	5.23	35.82	-30.85	-25	-5.85	Vertical
7530	-64.33	5.67	36.86	-33.14	-25	-8.14	Vertical
7530	-61.16	5.67	36.86	-29.97	-25	-4.97	Horizontal
Test Results for Mid Channel 2535MHz							
5070	-62.05	5.23	35.82	-31.46	-25	-6.46	Horizontal
5070	-61.16	5.23	35.82	-30.57	-25	-5.57	Vertical
7605	-63.99	5.67	36.85	-32.81	-25	-7.81	Vertical
7605	-64.91	5.67	36.85	-33.73	-25	-8.73	Horizontal
Test Results for High Channel 2560MHz							
5120	-60.13	5.24	35.83	-29.54	-25	-4.54	Horizontal
5120	-65.14	5.24	35.83	-34.55	-25	-9.55	Vertical
7680	-65.10	5.70	36.88	-33.92	-25	-8.92	Vertical
7680	-65.21	5.70	36.88	-34.03	-25	-9.03	Horizontal

Note: Spurious Emission Level = Spectrum Analyzer Read Value + Cable Loss+ Antenna Factor + 11.74
 . Margin = Spurious Emission Level - Limit
 . Both QPSK and 16QAM has been tested, the worst case is QPSK mode, the report just reported the worst case.

9.5 LTE BAND 66

QPSK EIRP POWER FOR LTE BAND 66 (1.4MHZ BANDWIDTH)

Test Results for Low Channel 1710.7MHz							
Frequency (MHz)	Spectrum Analyzer (dBm)	Cable Loss (dB)	Antenna Factor (dB/m)	Spurious Emission Level (dBm)	Limit (dBm)	Margin(dBm)	Polarity
3421.4	-55.20	2.61	27.28	-30.53	-13	-17.53	Horizontal
3421.4	-59.72	2.61	27.28	-35.05	-13	-22.05	Vertical
5132.1	-61.65	2.87	27.59	-36.93	-13	-23.93	Vertical
5132.1	-49.55	2.87	27.59	-24.83	-13	-11.83	Horizontal
Test Results for Mid Channel 1745MHz							
3490	-52.89	2.62	27.3	-28.21	-13	-15.21	Horizontal
3490	-62.16	2.62	27.3	-37.48	-13	-24.48	Vertical
5337.9	-60.20	2.87	27.62	-35.45	-13	-22.45	Vertical
5337.9	-58.26	2.87	27.62	-33.51	-13	-20.51	Horizontal
Test Results for High Channel 1779.3MHz							
3558.6	-59.43	2.66	27.28	-34.81	-13	-21.81	Horizontal
3558.6	-54.66	2.66	27.28	-30.04	-13	-17.04	Vertical
5337.9	-55.35	2.88	27.6	-30.63	-13	-17.63	Vertical
5337.9	-60.08	2.88	27.6	-35.36	-13	-22.36	Horizontal

QPSK EIRP POWER FOR LTE BAND 66 (20MHZ BANDWIDTH)

Test Results for Low Channel 1720MHz							
Frequency (MHz)	Spectrum Analyzer (dBm)	Cable Loss (dB)	Antenna Factor (dB/m)	Spurious Emission Level (dBm)	Limit (dBm)	Margin(dBm)	Polarity
3440	-51.19	2.62	27.3	-26.51	-13	-13.51	Horizontal
3440	-57.21	2.62	27.3	-32.53	-13	-19.53	Vertical
5160	-59.98	2.87	27.62	-35.23	-13	-22.23	Vertical
5160	-56.51	2.87	27.62	-31.76	-13	-18.76	Horizontal
Test Results for Mid Channel 1745MHz							
3490	-56.03	2.62	27.3	-31.35	-13	-18.35	Horizontal
3490	-55.05	2.62	27.3	-30.37	-13	-17.37	Vertical
5337.9	-59.83	2.87	27.62	-35.08	-13	-22.08	Vertical
5337.9	-57.64	2.87	27.62	-32.89	-13	-19.89	Horizontal
Test Results for High Channel 1770MHz							
3540	-56.47	2.62	27.3	-31.79	-13	-18.79	Horizontal
3540	-54.67	2.62	27.3	-29.99	-13	-16.99	Vertical
5310	-54.39	2.87	27.62	-29.64	-13	-16.64	Vertical
5310	-52.28	2.87	27.62	-27.53	-13	-14.53	Horizontal

Note:

1. We were tested all Configuration refer 3GPP TS134 121.
2. Spurious Emission Level = Spectrum Analyzer Read Value + Cable Loss+ Antenna Factor + 11.74
3. Margin = Spurious Emission Level - Limit
4. Both QPSK and 16QAM has been tested, the worst case is QPSK mode, the report just reported the worst case.

10. FREQUENCY STABILITY

RULE PART(S)

FCC: §2.1055, §22.355, §24.235, §27.54

LIMITS

§22.355 - The carrier frequency shall not depart from the reference frequency in excess of ± 2.5 ppm for mobile stations.

§24.235 - The frequency stability shall be sufficient to ensure that the fundamental emission stays within the authorized frequency block.

TEST PROCEDURE

Use CMW 500 with Frequency Error measurement capability.

- Temp. = -30° to $+50^{\circ}\text{C}$
- Voltage = low voltage, DC 34V, Normal, DC 3.85V and High voltage, DC 4.2V.

Frequency Stability vs Temperature:

The EUT is placed inside a temperature chamber. The temperature is set to -30°C and allowed to stabilize. After sufficient soak time, the transmitting frequency error is measured. The temperature is increased by 10 degrees, allowed to stabilize and soak, and then the measurement is repeated. This is repeated until $+50^{\circ}\text{C}$ is reached.

Frequency Stability vs Voltage:

The peak frequency error is recorded (worst-case).

MODES TESTED

- LTE Band2
LTE Band 4
- LTE Band5
LTE Band 7
LTE Band 66

RESULTS

See the following pages.

10.1 LTE BAND 2

Band 2 QPSK, (20MHz BANDWIDTH RB size 100 RB Offset 0)

Frequency error vs. Voltage

Voltage [Vdc]	Frequency [MHz]	Frequency* Error[Hz]	Frequency Error[ppm]	Limit [ppm]
3.4	1880	16	0.00851	2.5
3.8	1880	3	0.00160	2.5
4.2	1880	11	0.00585	2.5

Frequency error vs. Temperature

Temperature [° C]	Frequency [MHz]	Frequency* Error[Hz]	Frequency Error[ppm]	Limit [ppm]
Normal (25C)	1880	1	0.00053	2.5
Extreme (50C)	1880	14	0.00745	2.5
Extreme (40C)	1880	4	0.00213	2.5
Extreme (30C)	1880	5	0.00266	2.5
Extreme (10C)	1880	1	0.00053	2.5
Extreme (0C)	1880	10	0.00532	2.5
Extreme (-10C)	1880	12	0.00638	2.5
Extreme (-20C)	1880	5	0.00266	2.5
Extreme (-30C)	1880	7	0.00372	2.5

Band 2 16QAM, (20MHz BANDWIDTH RB size 100 RB Offset 0)

Frequency error vs. Voltage

Voltage [Vdc]	Frequency [MHz]	Frequency* Error[Hz]	Frequency Error[ppm]	Limit [ppm]
3.4	1880	20	0.01064	2.5
3.85	1880	11	0.00585	2.5
4.2	1880	15	0.00798	2.5

Frequency error vs. Temperature

Temperature [° C]	Frequency [MHz]	Frequency* Error[Hz]	Frequency Error[ppm]	Limit [ppm]
Normal (25C)	1880	2	0.00106	2.5
Extreme (50C)	1880	4	0.00213	2.5
Extreme (40C)	1880	6	0.00319	2.5
Extreme (30C)	1880	17	0.00904	2.5
Extreme (10C)	1880	13	0.00691	2.5
Extreme (0C)	1880	0	0.00000	2.5
Extreme (-10C)	1880	17	0.00904	2.5
Extreme (-20C)	1880	10	0.00532	2.5
Extreme (-30C)	1880	6	0.00319	2.5

*Note: Frequency error measurements were made by using the build-in capability of the Wireless Communication Test Set.

10.2 LTE BAND 4

Band 4 QPSK, (20MHz BANDWIDTH RB size 100 RB Offset 0)

Frequency error vs. Voltage

Voltage [Vdc]	Frequency [MHz]	Frequency* Error[Hz]	Frequency Error[ppm]	Limit [ppm]
3.4	1732.5	16	0.00924	2.5
3.85	1732.5	15	0.00866	2.5
4.2	1732.5	13	0.00750	2.5

Frequency error vs. Temperature

Temperature [°C]	Frequency [MHz]	Frequency* Error[Hz]	Frequency Error[ppm]	Limit [ppm]
Normal (25C)	1732.5	14	0.00808	2.5
Extreme (50C)	1732.5	16	0.00924	2.5
Extreme (40C)	1732.5	2	0.00115	2.5
Extreme (30C)	1732.5	5	0.00289	2.5
Extreme (10C)	1732.5	12	0.00693	2.5
Extreme (0C)	1732.5	13	0.00750	2.5
Extreme (-10C)	1732.5	4	0.00231	2.5
Extreme (-20C)	1732.5	6	0.00346	2.5
Extreme (-30C)	1732.5	10	0.00577	2.5

Band 4 16QAM, (20MHz BANDWIDTH RB size 100 RB Offset 0)

Frequency error vs. Voltage

Voltage [Vdc]	Frequency [MHz]	Frequency* Error[Hz]	Frequency Error[ppm]	Limit [ppm]
3.4	1732.5	9	0.00519	2.5
3.85	1732.5	10	0.00577	2.5
4.2	1732.5	14	0.00808	2.5

Frequency error vs. Temperature

Temperature [°C]	Frequency [MHz]	Frequency* Error[Hz]	Frequency Error[ppm]	Limit [ppm]
Normal (25C)	1732.5	14	0.00808	2.5
Extreme (50C)	1732.5	15	0.00866	2.5
Extreme (40C)	1732.5	11	0.00635	2.5
Extreme (30C)	1732.5	13	0.00750	2.5
Extreme (10C)	1732.5	7	0.00404	2.5
Extreme (0C)	1732.5	1	0.00058	2.5
Extreme (-10C)	1732.5	5	0.00289	2.5
Extreme (-20C)	1732.5	10	0.00577	2.5
Extreme (-30C)	1732.5	3	0.00173	2.5

***Note:** Frequency error measurements were made by using the build-in capability of the Wireless Communication Test Set.

10.3 LTE BAND 5

Band 5 QPSK, (10MHz BANDWIDTH RB size 50 RB Offset 0)

Frequency error vs. Voltage

Voltage [Vdc]	Frequency [MHz]	Frequency* Error[Hz]	Frequency Error[ppm]	Limit [ppm]
3.4	836.5	10	0.01195	2.5
3.85	836.5	9	0.01076	2.5
4.2	836.5	11	0.01315	2.5

Frequency error vs. Temperature

Temperature [° C]	Frequency [MHz]	Frequency* Error[Hz]	Frequency Error[ppm]	Limit [ppm]
Normal (25C)	836.5	3	0.00359	2.5
Extreme (50C)	836.5	2	0.00239	2.5
Extreme (40C)	836.5	8	0.00956	2.5
Extreme (30C)	836.5	11	0.01315	2.5
Extreme (10C)	836.5	13	0.01554	2.5
Extreme (0C)	836.5	12	0.01435	2.5
Extreme (-10C)	836.5	5	0.00598	2.5
Extreme (-20C)	836.5	3	0.00359	2.5
Extreme (-30C)	836.5	7	0.00837	2.5

Band 5 16QAM, (10MHz BANDWIDTH RB size 50 RB Offset 0)

Frequency error vs. Voltage

Voltage [Vdc]	Frequency [MHz]	Frequency* Error[Hz]	Frequency Error[ppm]	Limit [ppm]
3.4	836.5	14	0.01674	2.5
3.85	836.5	16	0.01913	2.5
4.2	836.5	13	0.01554	2.5

Frequency error vs. Temperature

Temperature [° C]	Frequency [MHz]	Frequency* Error[Hz]	Frequency Error[ppm]	Limit [ppm]
Normal (25C)	836.5	11	0.01315	2.5
Extreme (50C)	836.5	9	0.01076	2.5
Extreme (40C)	836.5	12	0.01435	2.5
Extreme (30C)	836.5	13	0.01554	2.5
Extreme (10C)	836.5	5	0.00598	2.5
Extreme (0C)	836.5	9	0.01076	2.5
Extreme (-10C)	836.5	10	0.01195	2.5
Extreme (-20C)	836.5	9	0.01076	2.5
Extreme (-30C)	836.5	7	0.00837	2.5

***Note:** Frequency error measurements were made by using the build-in capability of the Wireless Communication Test Set.

10.4 LTE BAND 7

Band 7 QPSK, (20MHz BANDWIDTH RB size 100 RB Offset 0)

Frequency error vs. Voltage

Voltage [Vdc]	Frequency [MHz]	Frequency* Error[Hz]	Frequency Error[ppm]	Limit [ppm]
3.4	2535	17	0.00671	2.5
3.85	2535	19	0.00750	2.5
4.2	2535	11	0.00434	2.5

Frequency error vs. Temperature

Temperature [° C]	Frequency [MHz]	Frequency* Error[Hz]	Frequency Error[ppm]	Limit [ppm]
Normal (25C)	2535	13	0.00513	2.5
Extreme (50C)	2535	10	0.00394	2.5
Extreme (40C)	2535	11	0.00434	2.5
Extreme (30C)	2535	8	0.00316	2.5
Extreme (10C)	2535	13	0.00513	2.5
Extreme (0C)	2535	18	0.00710	2.5
Extreme (-10C)	2535	13	0.00513	2.5
Extreme (-20C)	2535	9	0.00355	2.5
Extreme (-30C)	2535	11	0.00434	2.5

Band 7 16QAM, (20MHz BANDWIDTH RB size 100 RB Offset 0)

Frequency error vs. Voltage

Voltage [Vdc]	Frequency [MHz]	Frequency* Error[Hz]	Frequency Error[ppm]	Limit [ppm]
3.4	2535	10	0.00394	2.5
3.85	2535	13	0.00513	2.5
4.2	2535	12	0.00473	2.5

Frequency error vs. Temperature

Temperature [° C]	Frequency [MHz]	Frequency* Error[Hz]	Frequency Error[ppm]	Limit [ppm]
Normal (25C)	2535	16	0.00631	2.5
Extreme (50C)	2535	13	0.00513	2.5
Extreme (40C)	2535	15	0.00592	2.5
Extreme (30C)	2535	12	0.00473	2.5
Extreme (10C)	2535	10	0.00394	2.5
Extreme (0C)	2535	14	0.00552	2.5
Extreme (-10C)	2535	13	0.00513	2.5
Extreme (-20C)	2535	11	0.00434	2.5
Extreme (-30C)	2535	9	0.00355	2.5

***Note:** Frequency error measurements were made by using the build-in capability of the Wireless Communication Test Set.

10.5 LTE BAND 66

Band 66 QPSK, (20MHz BANDWIDTH RB size 100 RB Offset 0)

Frequency error vs. Voltage

Voltage [Vdc]	Frequency [MHz]	Frequency* Error[Hz]	Frequency Error[ppm]	Limit [ppm]
3.4	1745	11	0.00630	2.5
3.85	1745	17	0.00974	2.5
4.2	1745	12	0.00688	2.5

Frequency error vs. Temperature

Temperature [° C]	Frequency [MHz]	Frequency* Error[Hz]	Frequency Error[ppm]	Limit [ppm]
Normal (25C)	1745	3	0.00172	2.5
Extreme (50C)	1745	9	0.00516	2.5
Extreme (40C)	1745	15	0.00860	2.5
Extreme (30C)	1745	12	0.00688	2.5
Extreme (10C)	1745	11	0.00630	2.5
Extreme (0C)	1745	14	0.00802	2.5
Extreme (-10C)	1745	13	0.00745	2.5
Extreme (-20C)	1745	9	0.00516	2.5
Extreme (-30C)	1745	7	0.00401	2.5

Band 66 16QAM, (20MHz BANDWIDTH RB size 100 RB Offset 0)

Frequency error vs. Voltage

Voltage [Vdc]	Frequency [MHz]	Frequency* Error[Hz]	Frequency Error[ppm]	Limit [ppm]
3.4	1745	14	0.00802	2.5
3.85	1745	10	0.00573	2.5
4.2	1745	19	0.01089	2.5

Frequency error vs. Temperature

Temperature [° C]	Frequency [MHz]	Frequency* Error[Hz]	Frequency Error[ppm]	Limit [ppm]
Normal (25C)	1745	5	0.00287	2.5
Extreme (50C)	1745	14	0.00802	2.5
Extreme (40C)	1745	6	0.00344	2.5
Extreme (30C)	1745	1	0.00057	2.5
Extreme (10C)	1745	7	0.00401	2.5
Extreme (0C)	1745	10	0.00573	2.5
Extreme (-10C)	1745	13	0.00745	2.5
Extreme (-20C)	1745	4	0.00229	2.5
Extreme (-30C)	1745	12	0.00688	2.5

***Note:** Frequency error measurements were made by using the build-in capability of the Wireless Communication Test Set.

11. Peak-to-Average Ratio

11.1 Description of the PAR Measurement

The peak-to-average ratio (PAR) of the transmission may not exceed 13 dB.

11.2 Measuring Instruments

See list of measuring instruments of this test report.

11.3 Test Procedures

1. The EUT was connected to Spectrum Analyzer and Base Station via power divider.
2. The RF output of EUT was connected to the spectrum analyzer by RF cable and attenuator. The path loss was compensated to the results for each measurement.
3. For LTE operating modes:
 - a. Set the CCDF (Complementary Cumulative Distribution Function) option in spectrum analyzer.
 - b. The highest RF powers were measured and recorded the maximum PAPR level associated with a probability of 0.1 %.

11.4 Test Setup

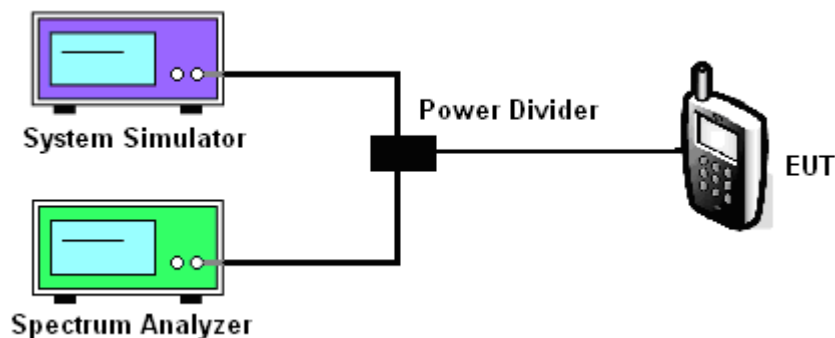

MODES TESTED

- LTE Band 2/4/5/7/66
-

Test data reference attachment.

----END OF REPORT----