



# HEYUAN XUNWEI MICROWAVE COMMUNICATION CO.,LTD

## Mobile antenna test report

RF: Kang Guangqi

Date: 2023.09.22

# Contents:

- 1、 Test equipment
- 2、 Passive data
- 3、 Antenna size diagram
- 4、 Contact information

# 1、 Test equipment

Wireless communications test set: CMW500

Network Analyzer: Agilent 5071B

Anechoic Chamber : SATIMO SG24



# 2、 Passive data

## 2.1 Main antenna Return Loss & VSWR

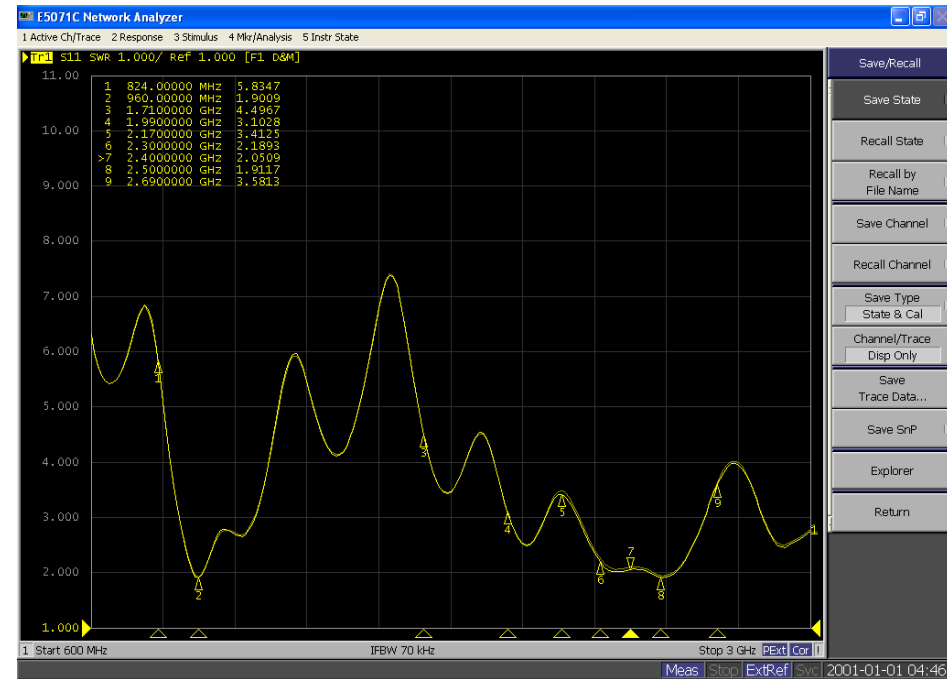

Frequency	960MHZ	2500MHZ
Return Loss	-10.4	-10.0
VSWR	1.9	1.9

# 2.2 Main antenna Peak Gain

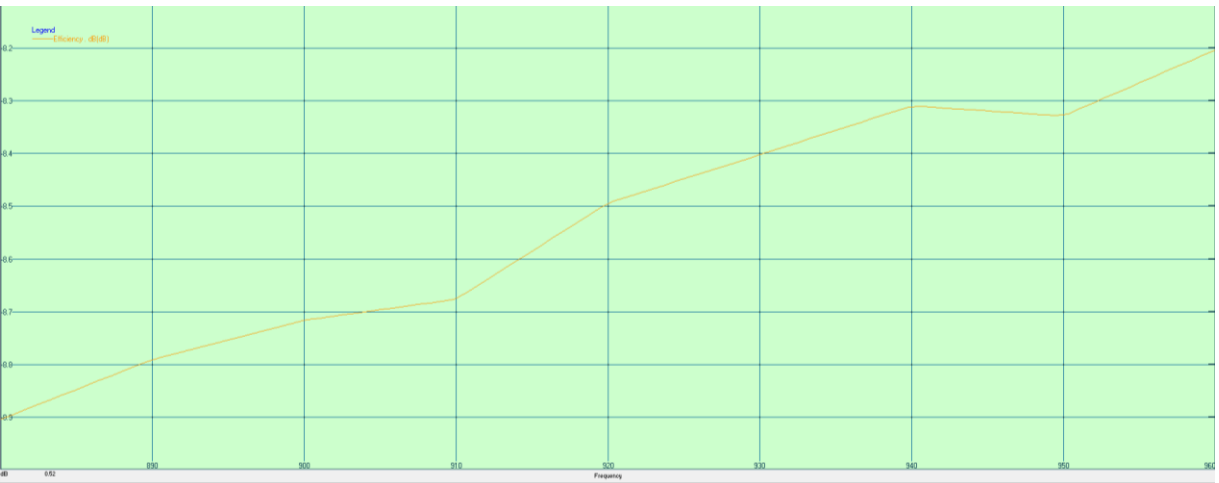
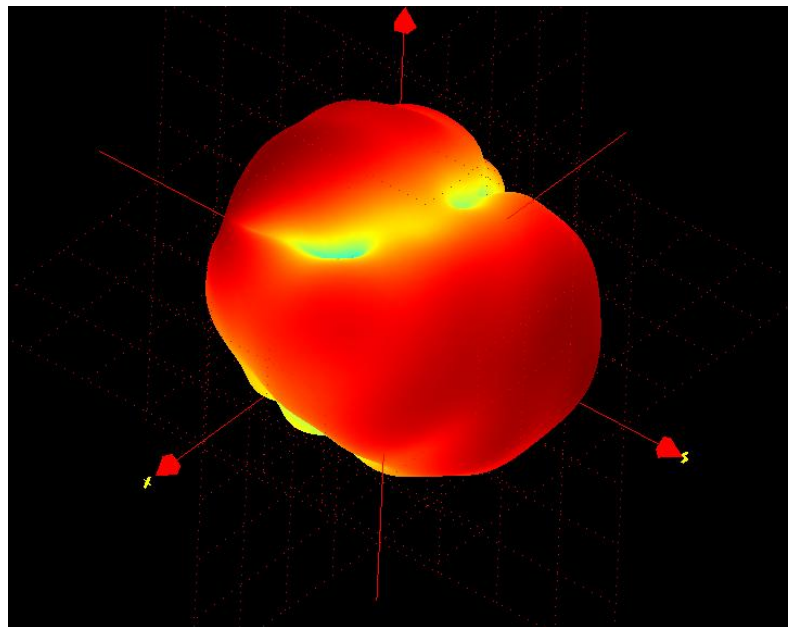
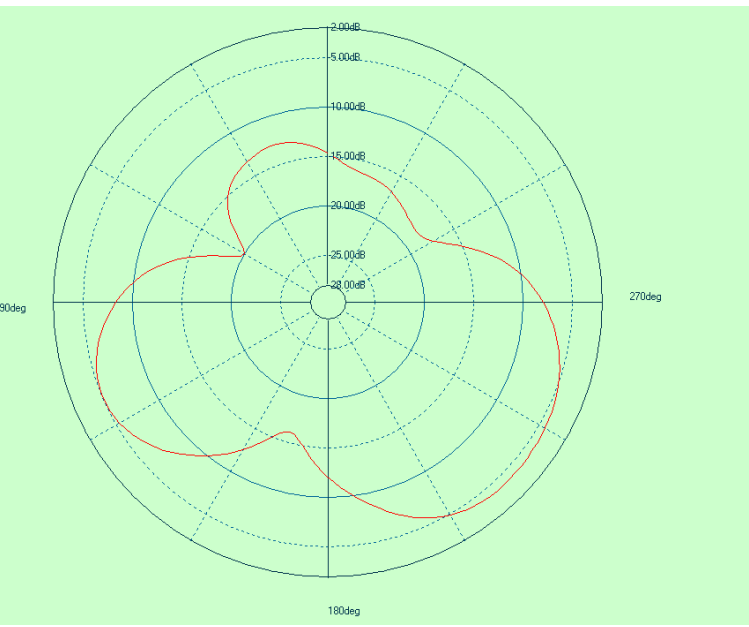

960MHZ	Peak Gain
XZ-Plane	-1.3
YZ-Plane	-1.5
XY-Plane	-1.0

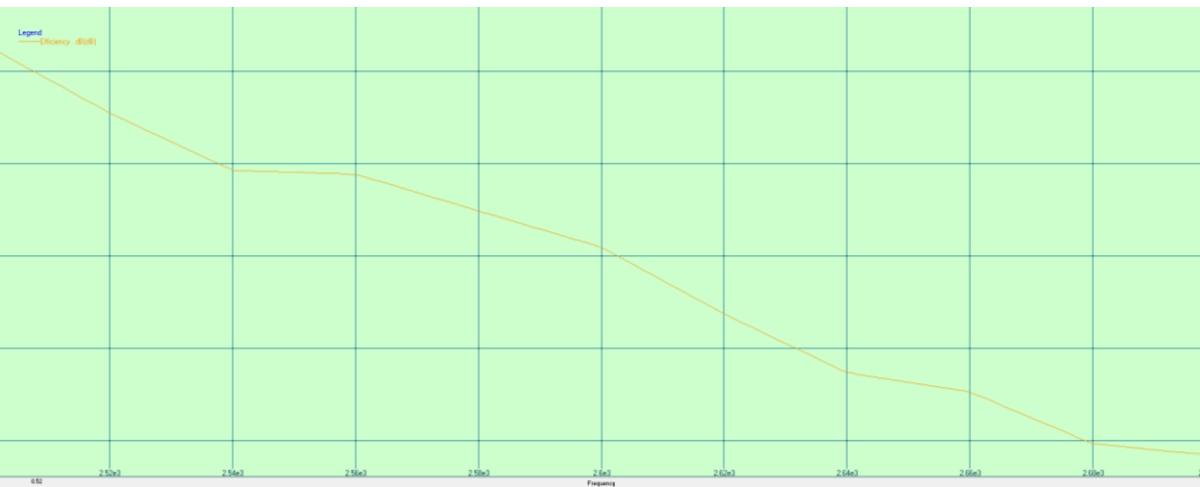
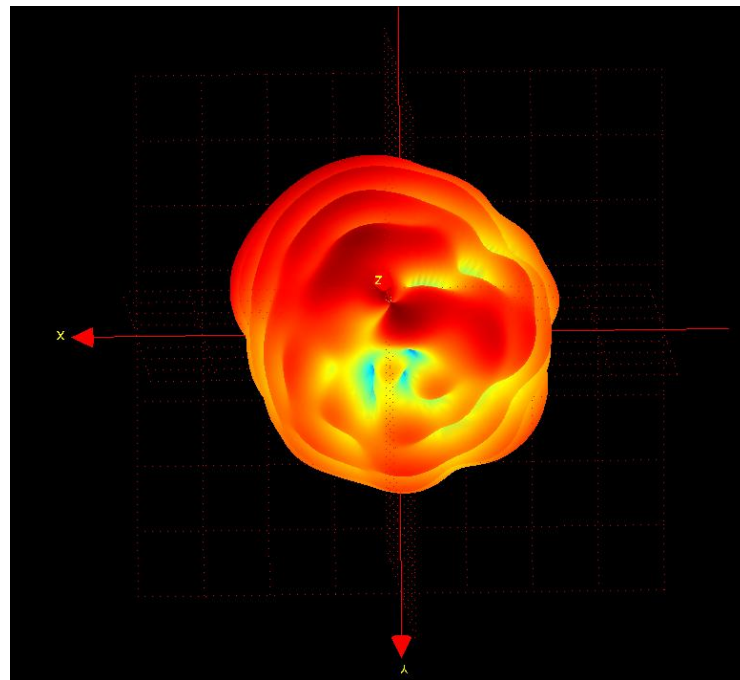
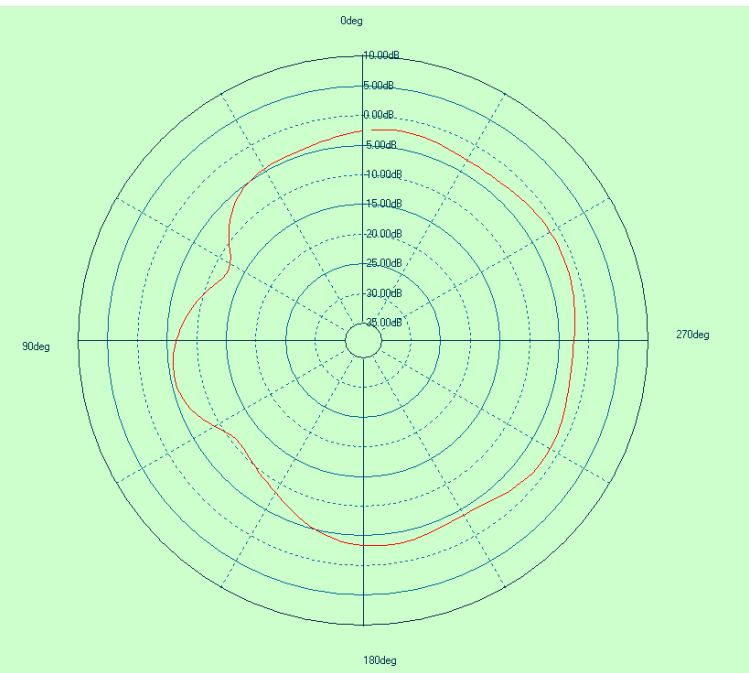

2500MHZ	Peak Gain
XZ-Plane	-0.8
YZ-Plane	-1.0
XY-Plane	-0.9

# 2.3 Main antenna Efficiency

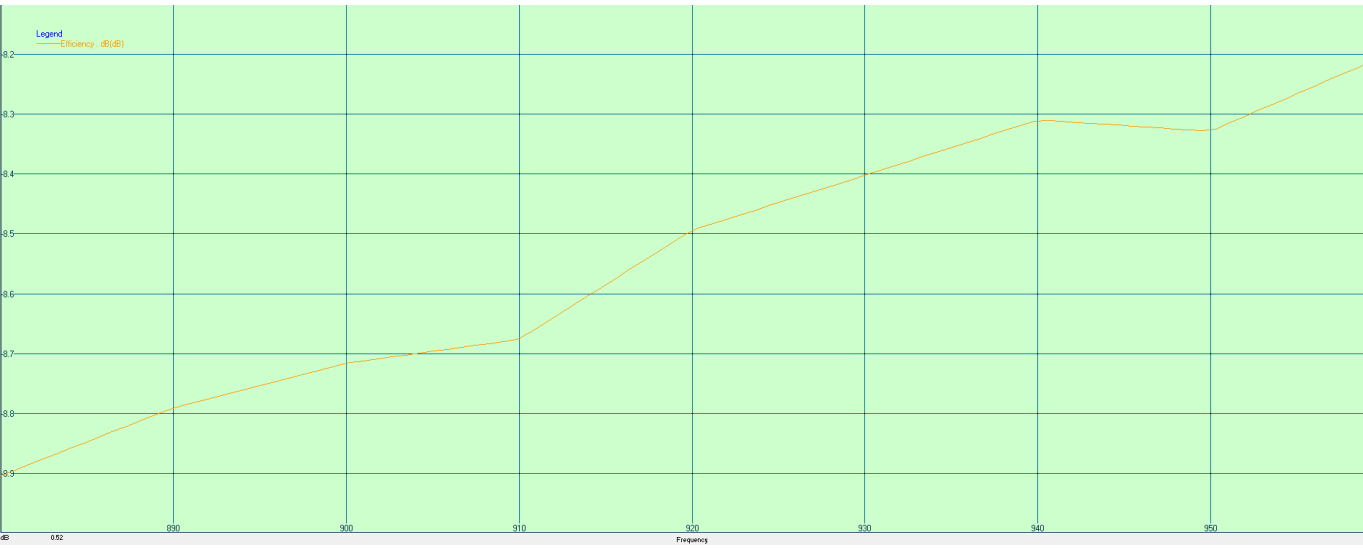

960MHZ

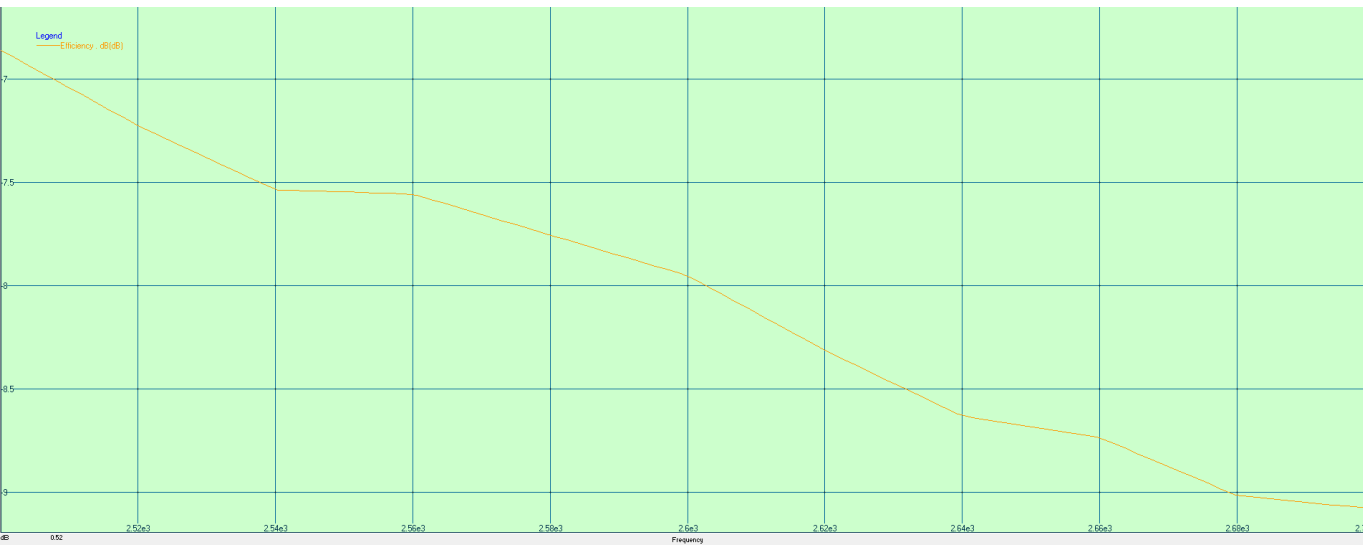

2500MHZ

Frequency	960MHZ	2500MHZ
Efficiency	27.3%	30.6%

# 2.4 Div antenna Return Loss

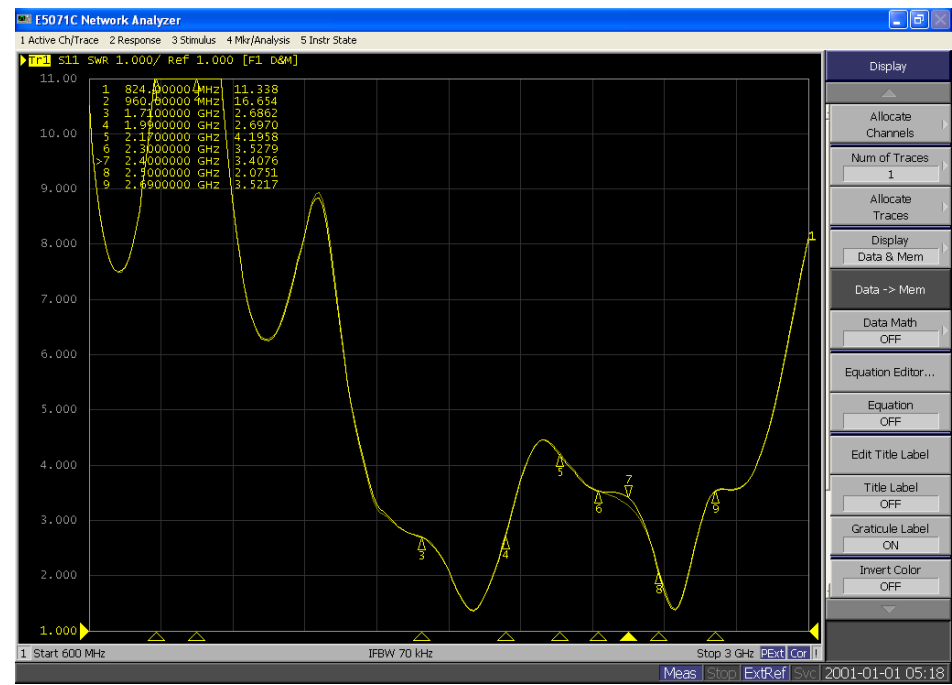
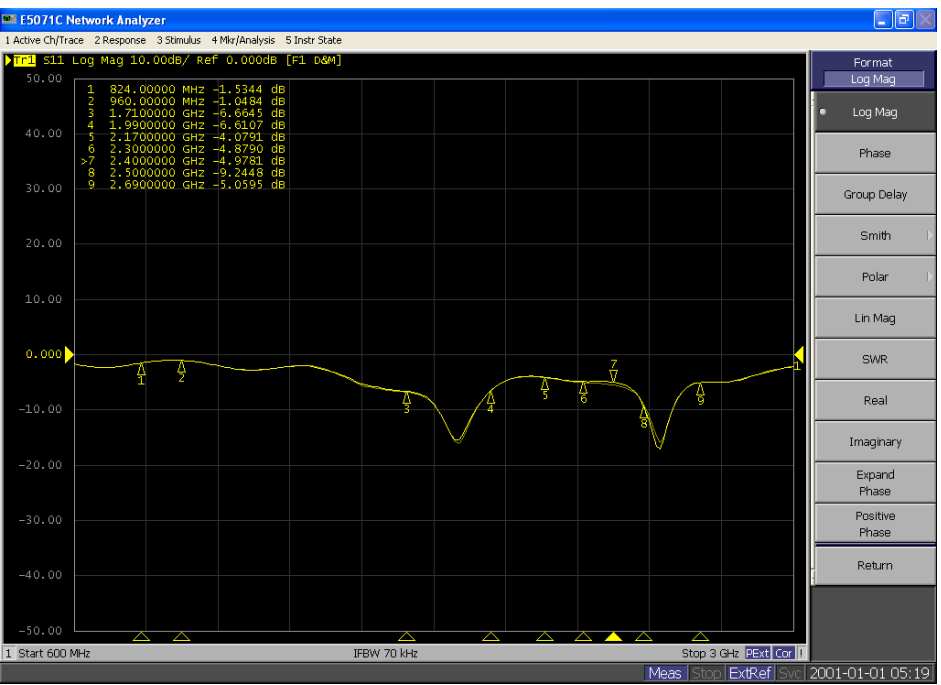

Frequency	1710MHZ	2170MHZ
Return Loss	-6.6	-4.0
VSWR	2.6	4.1



# 2.5 Div antenna Peak Gain

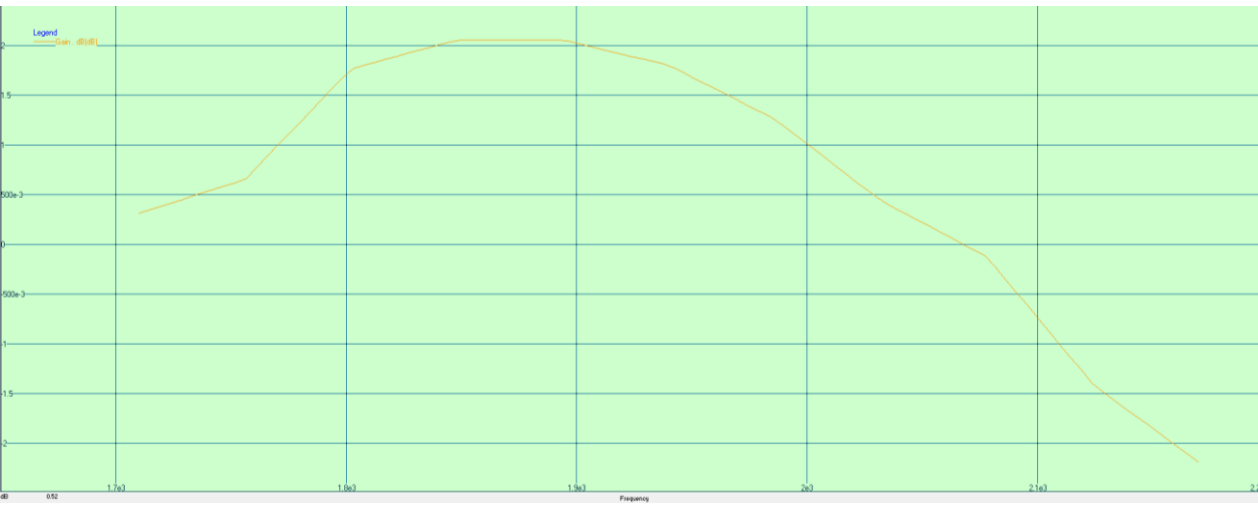
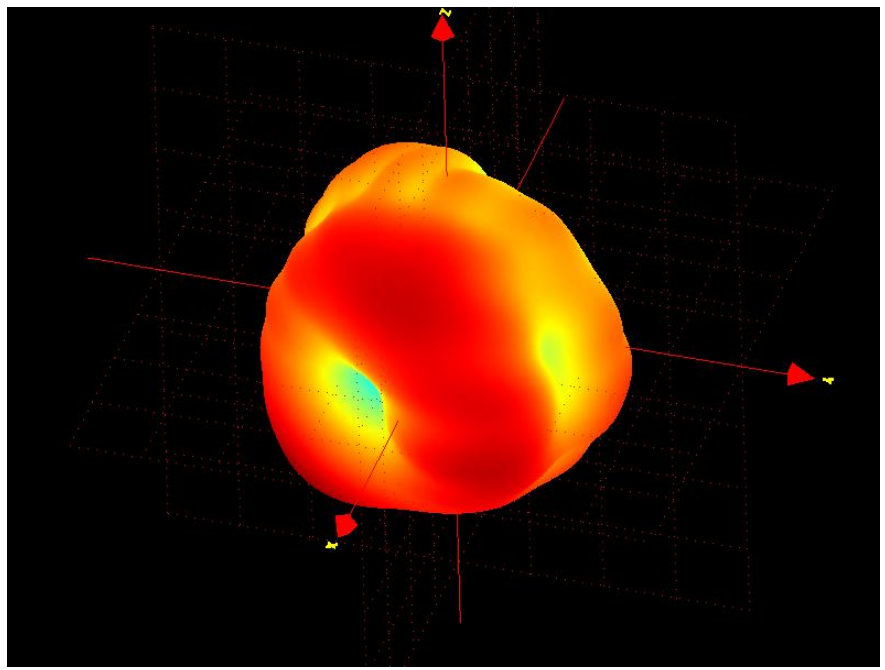
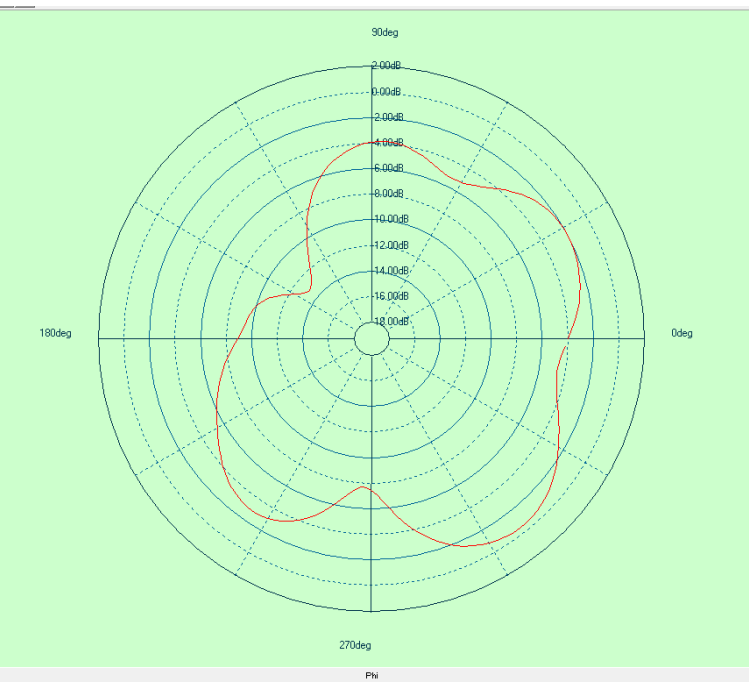

1710MHZ	Peak Gain
XZ-Plane	-0.7
YZ-Plane	-1.0
XY-Plane	-0.9

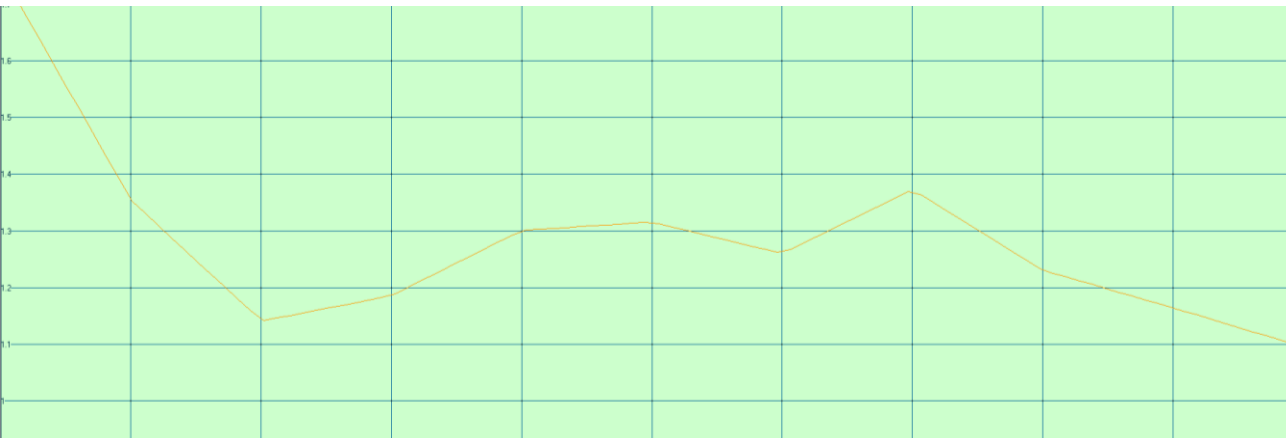
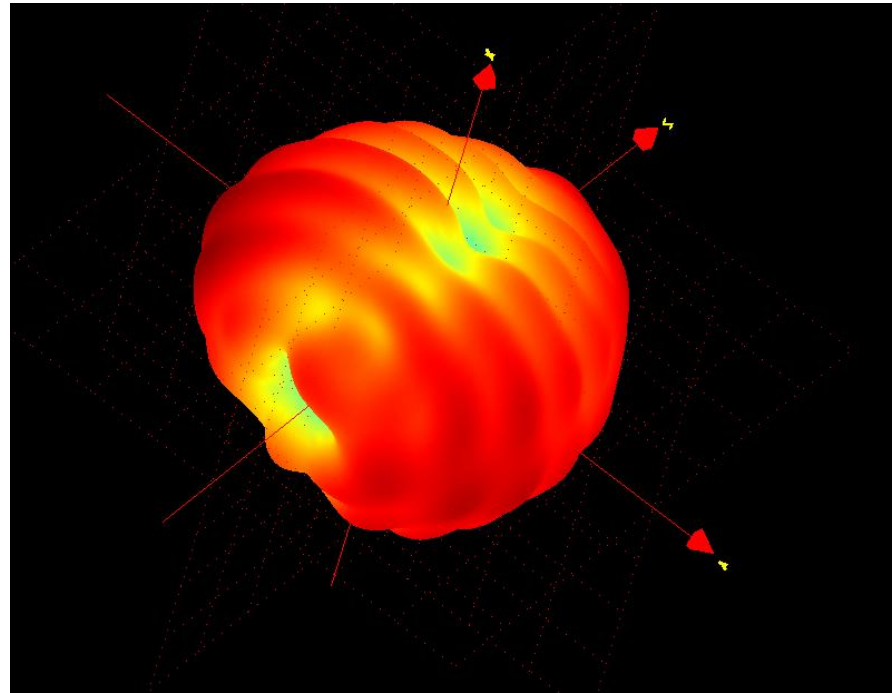
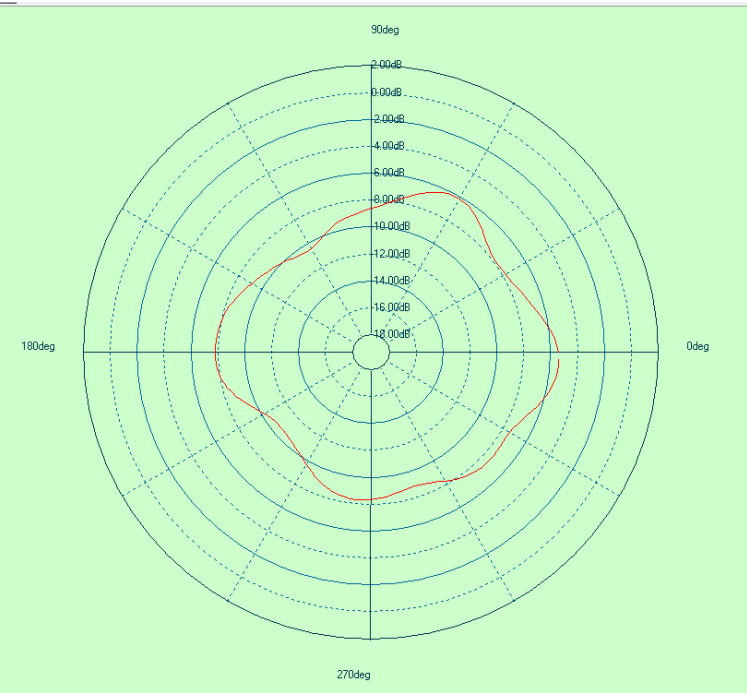

2170MHZ	Peak Gain
XZ-Plane	-1.1
YZ-Plane	-0.7
XY-Plane	-0.8

# 2.6 Div antenna Efficiency

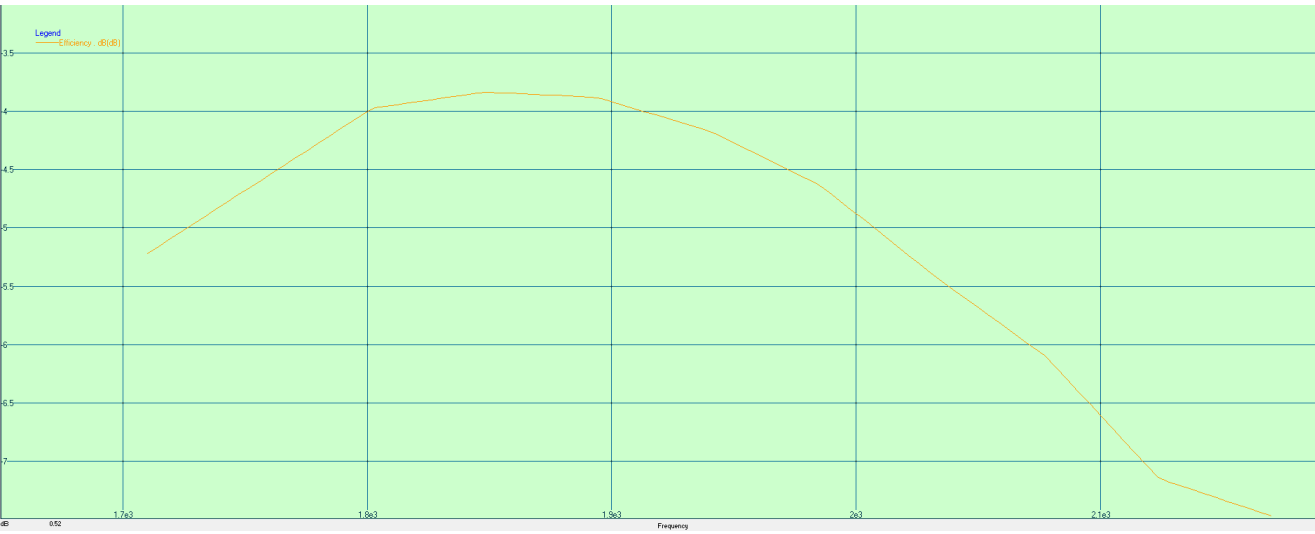

1710~2170MHZ

Frequency	1710MHZ	2170MHZ
Efficiency	-37.4%	-34.9%

# 2.7 GPS & WIFI antenna Return Loss

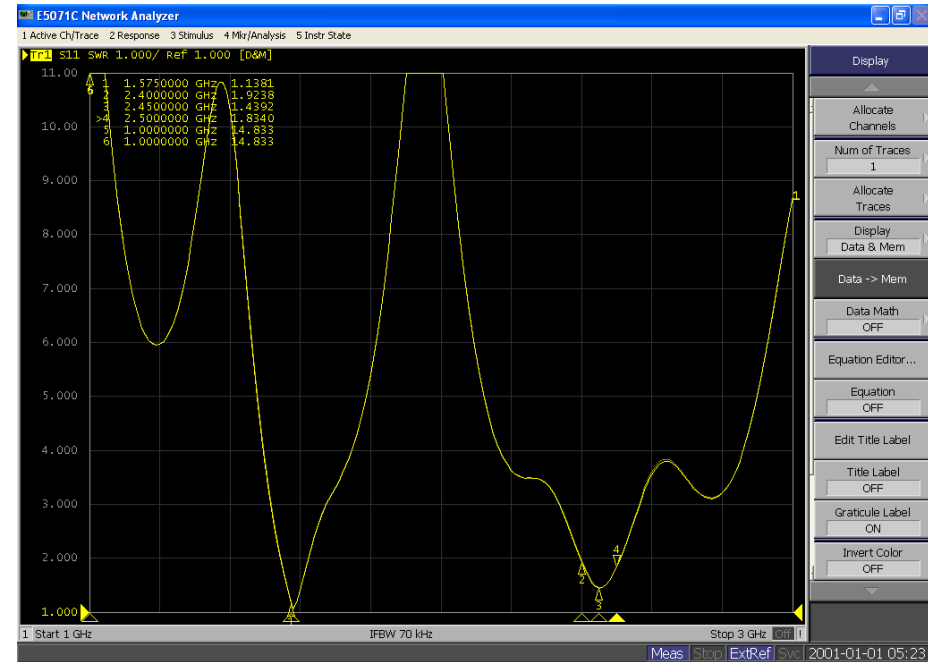
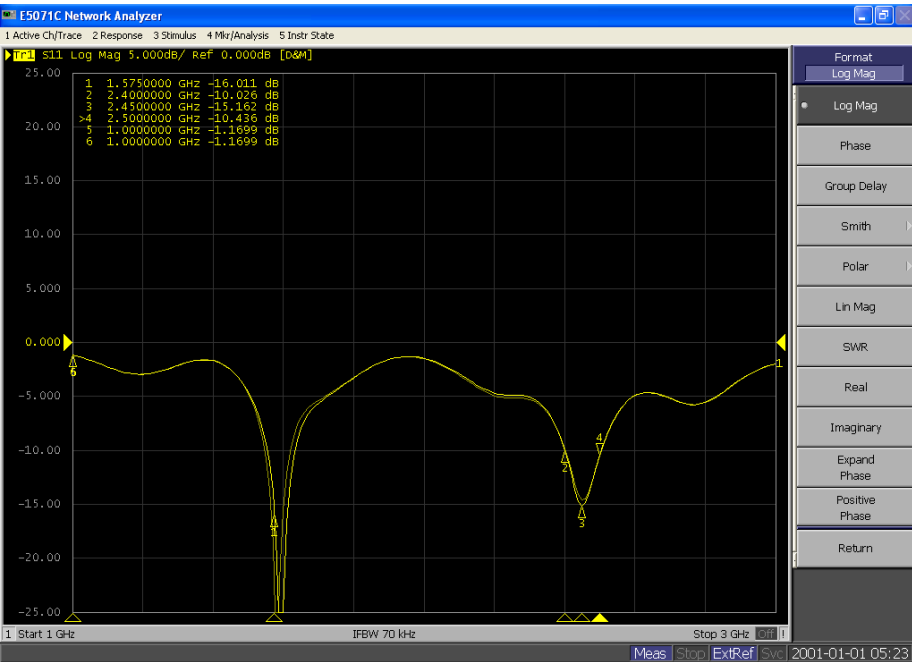

Frequency	1570MHZ	2450MHZ
Return Loss	-16.0	-15.1
VSWR	1.1	1.4

# 2.8 GPS & WIFI antenna Peak Gain

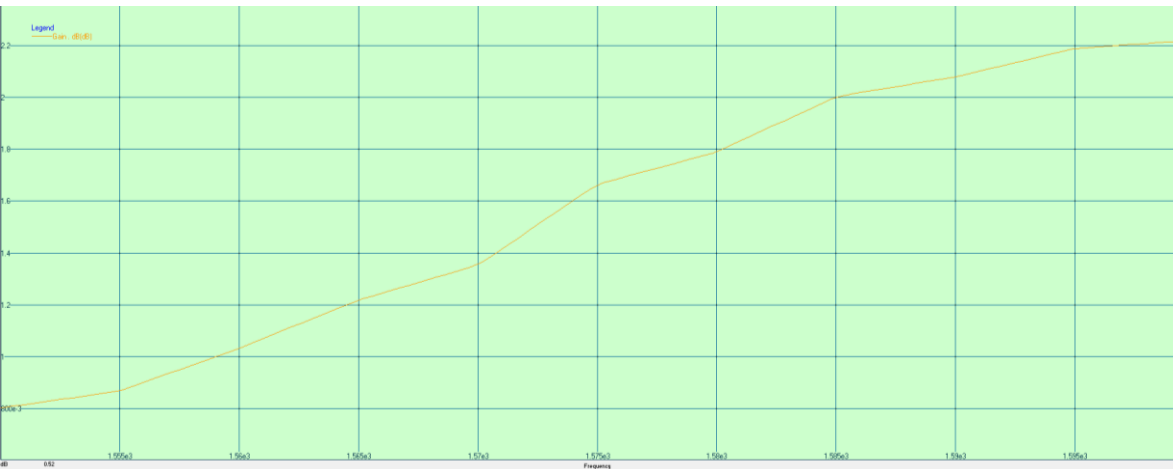
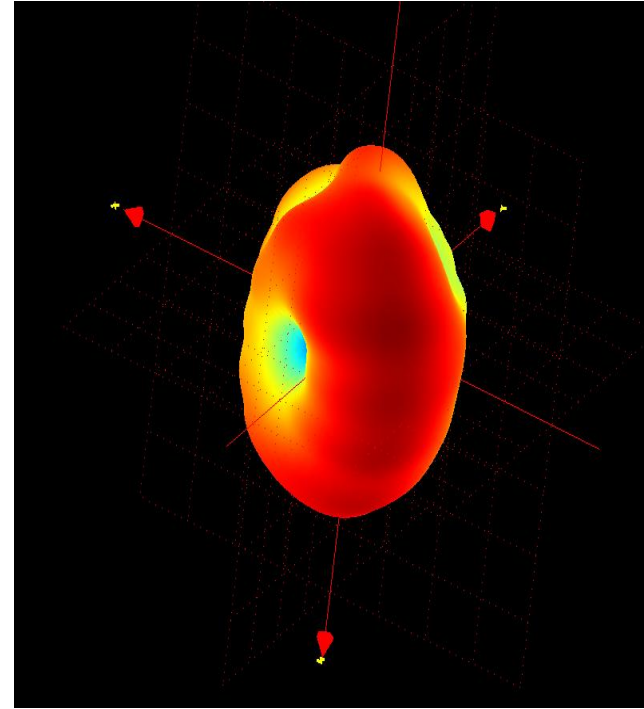
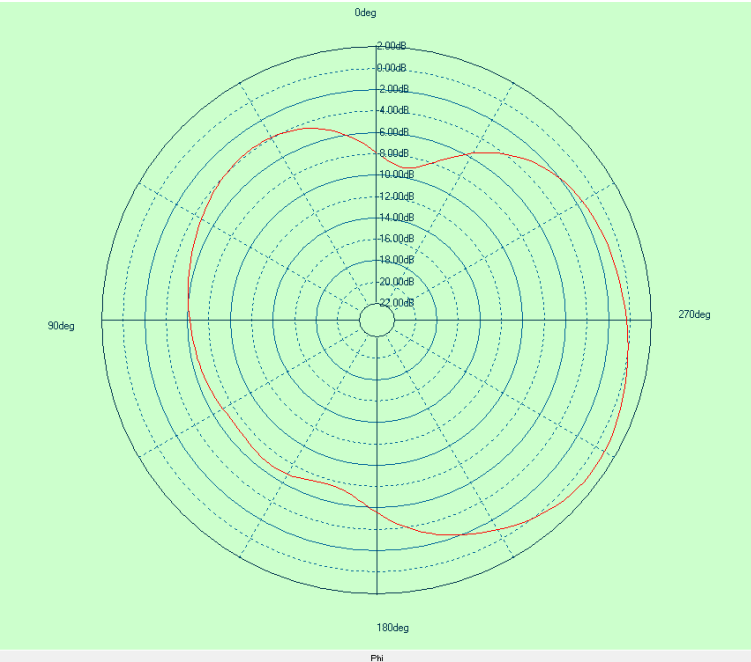

1575MHZ	Peak Gain
XZ-Plane	-0.6
YZ-Plane	0.3
XY-Plane	-0.8

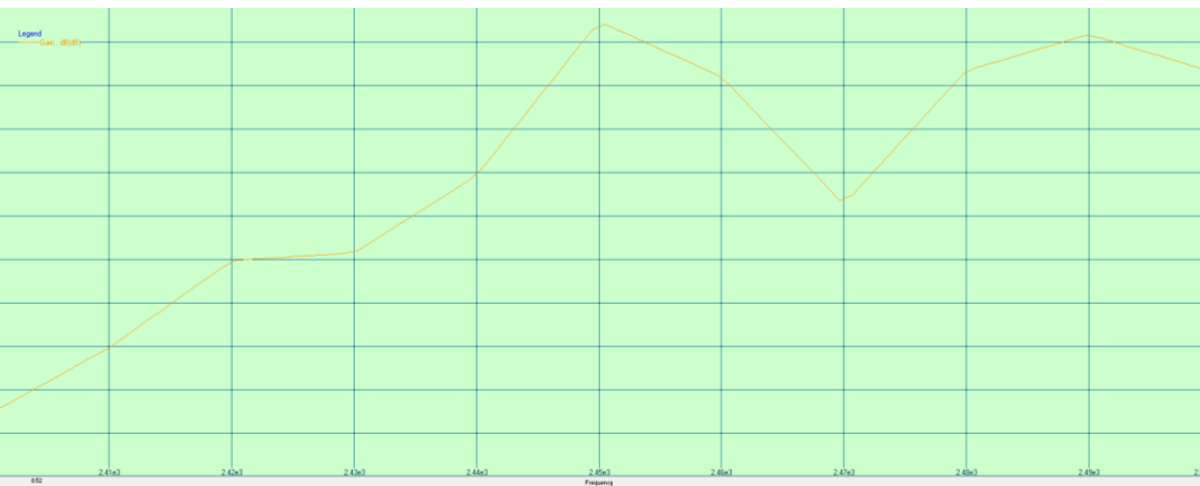
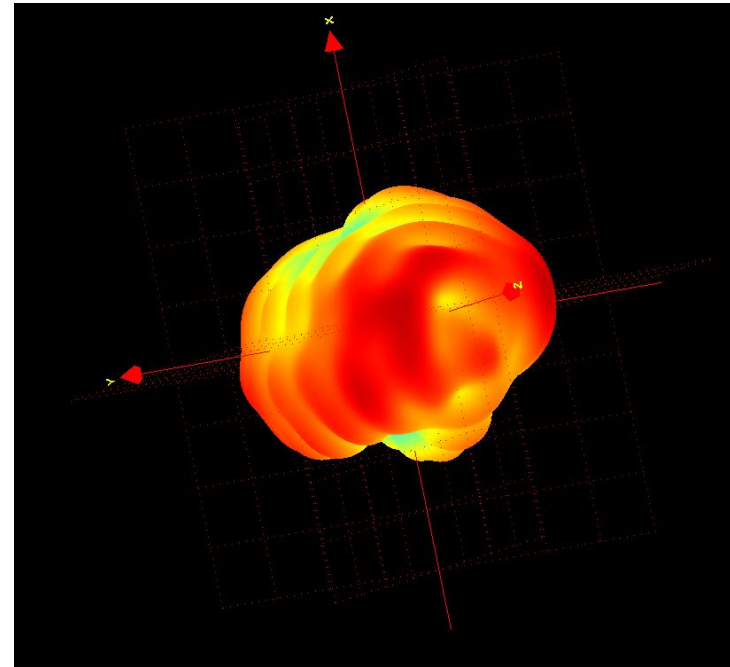
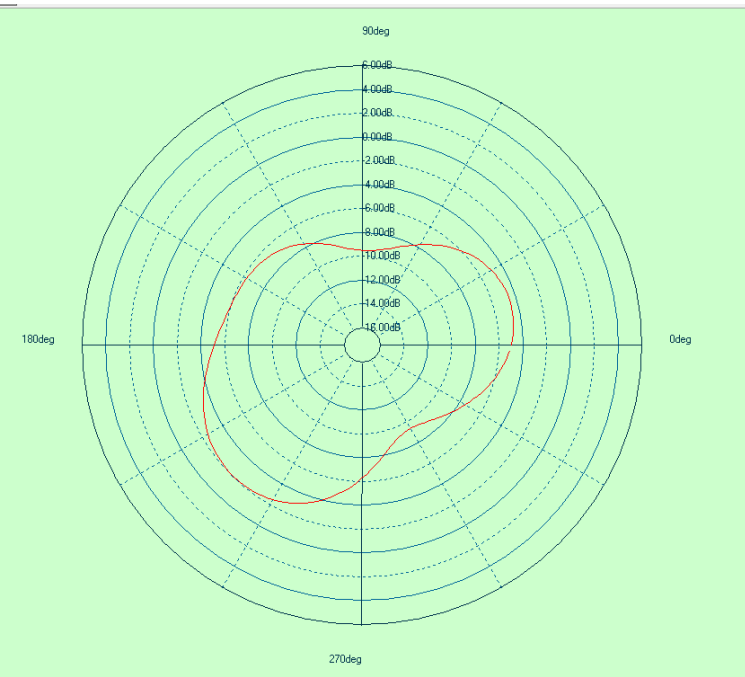

2450MHZ	Peak Gain
XZ-Plane	-0.7
YZ-Plane	-0.4
XY-Plane	0.2

# 2.9 GPS & WIFI antenna Efficiency

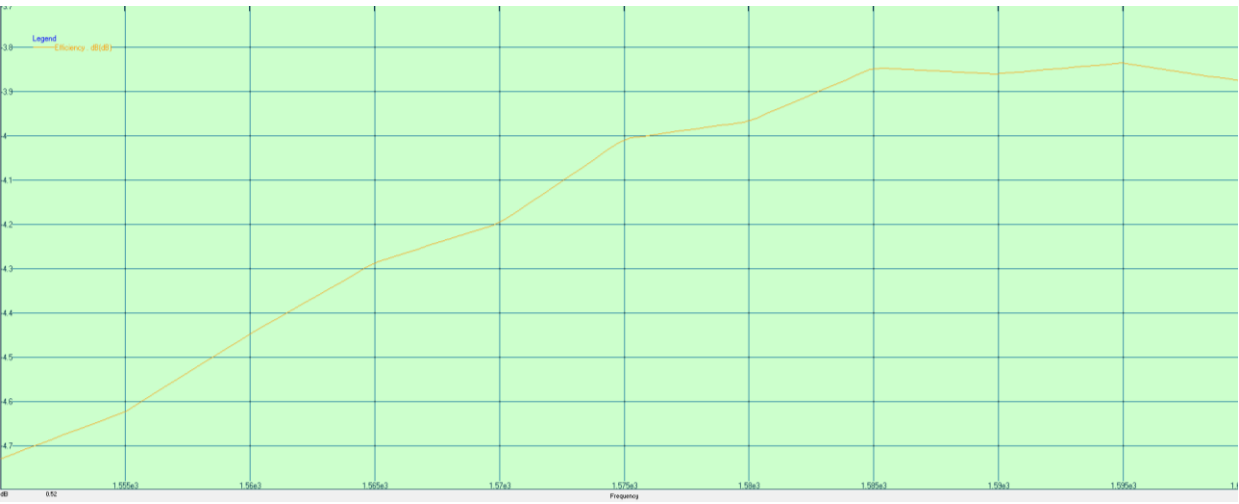

1575MHZ

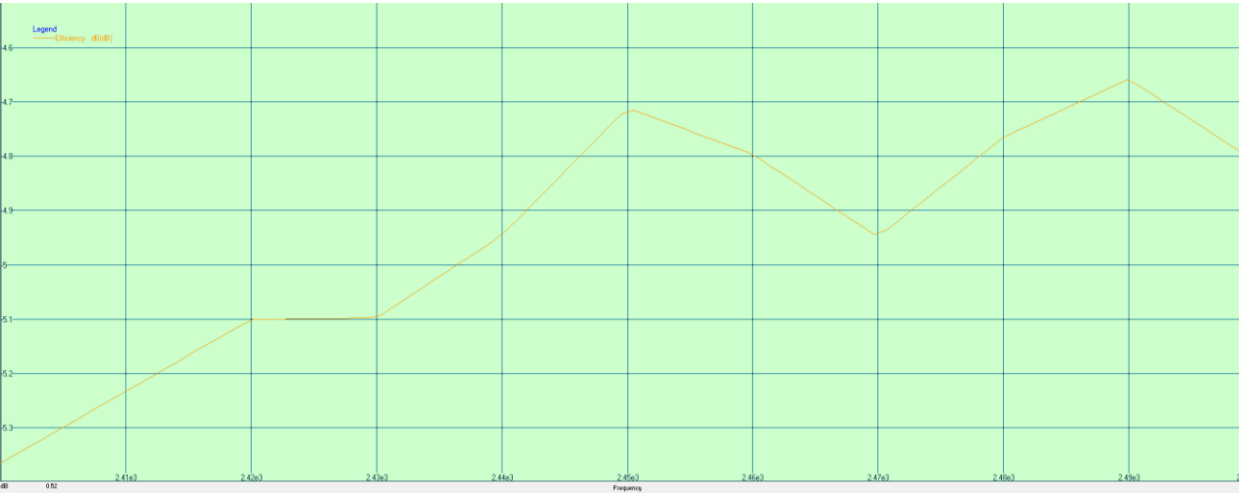

2450MHZ

Frequency	1570MHZ	2450MHZ
Efficiency	-35.3%	-38.2%

# 3-1、 Antenna size diagram

Main antenna

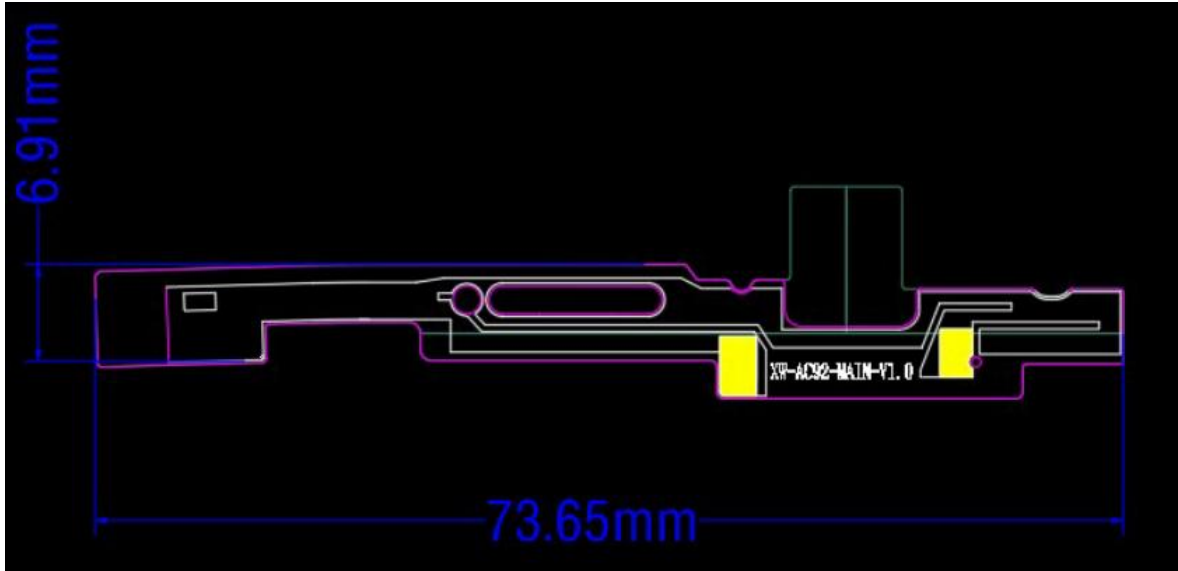

Diversity Antenna

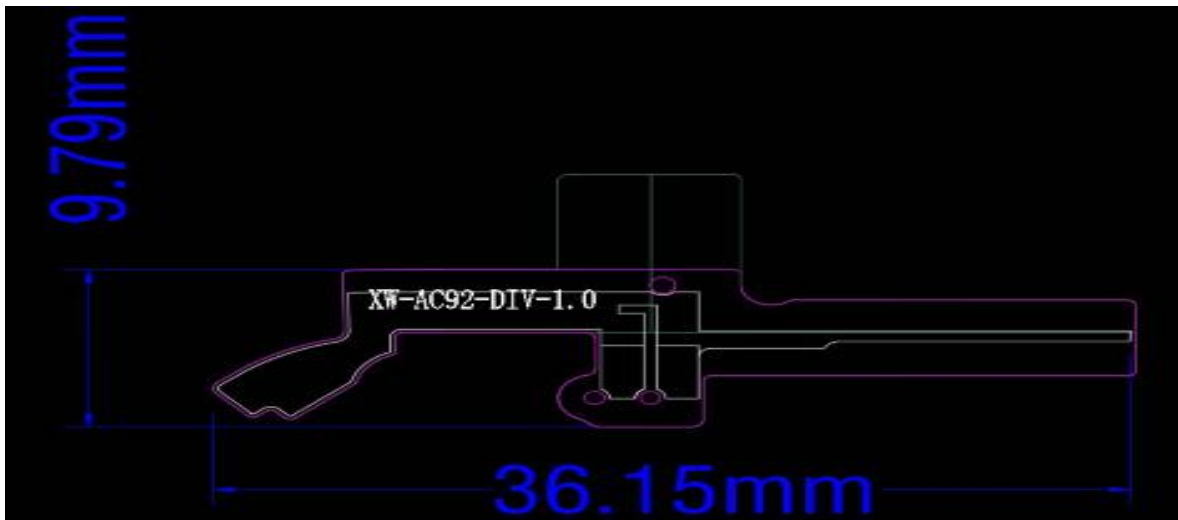



## 3-2、 Antenna size diagram

GPS/WIFI/BT antenna

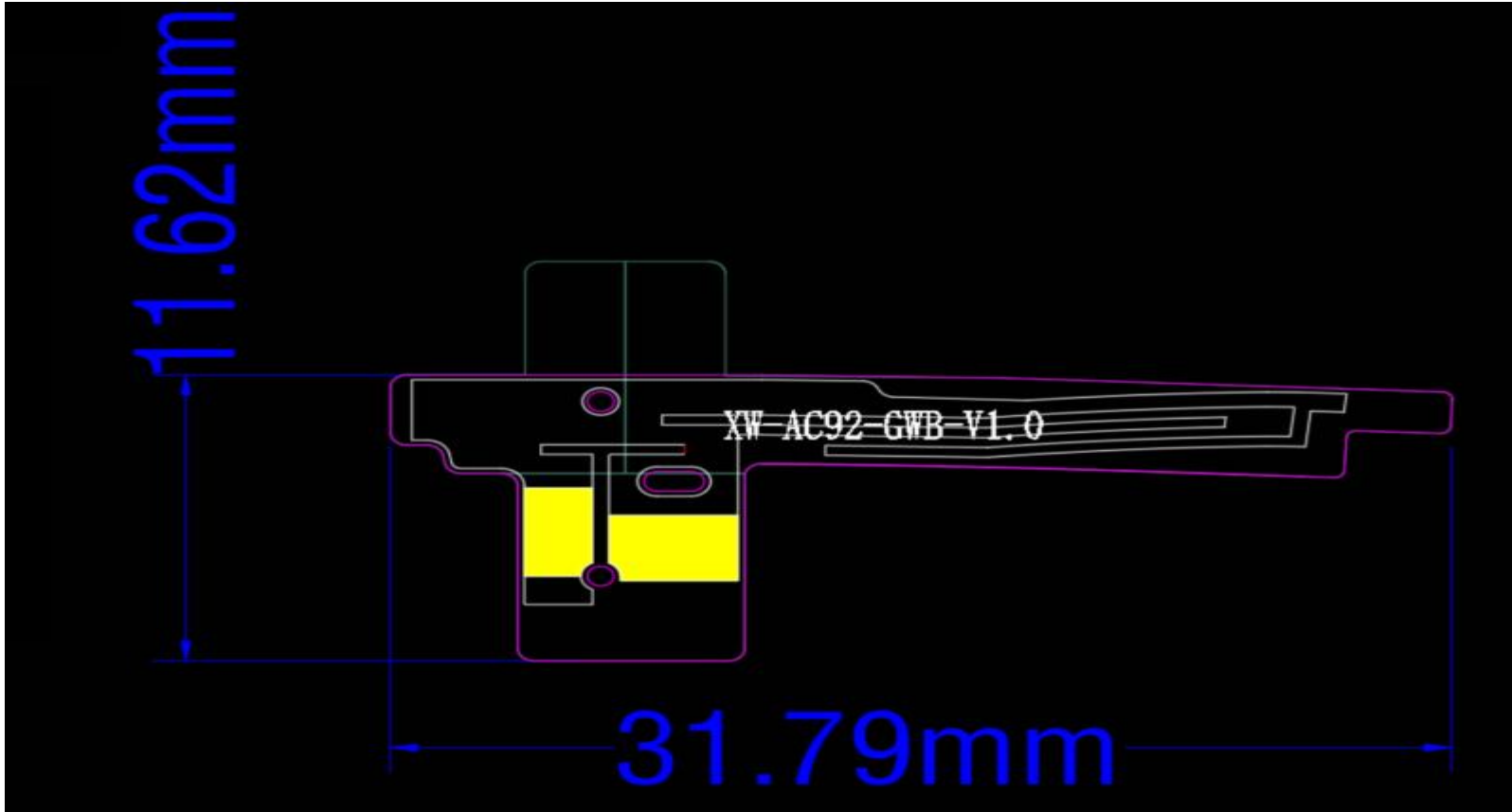

## 4 、 Contact information

Business manager: Yue Yongde	电话： 15072046607 邮箱： yueyd@xunweitx.com
RF Engineer: Kang Guangqi	电话： 13657910804 邮箱： kanggq@xunweitx.com
Structural Engineer: Li Wenbo	电话： 15919806329 邮箱： liwb@szcoe.com