

FCC CFR47 PART 22H, 24E, 27 CERTIFICATION TEST REPORT

FCC ID: 2AZYA-A60L

Product: Mobile Phone

Trade Mark: ACER

Model Number: SOSPIRO-A60L

Family Model: SOSPIRO-A60L-G

Report No.: S23071202209005

Prepared for

Senwa Global International, S.A. de C.V.

Carretera Mexico-Toluca No. 5324 PB, Colonia El Yaqui Del. Cuajimalpa de
Morelos, C.P. 05320 Ciudad de Mexico, Mexico

Prepared by

Shenzhen NTEK Testing Technology Co., Ltd.

1&5/F, Building C, 1&2/F, Building E, Fenda Science Park, Sanwei
Community, Hangcheng Street, Baoan District, Shenzhen, Guangdong, China

Tel. 400-800-6106, 0755-2320 0050, 0755-2320 0090

Website: <http://www.ntek.org.cn>

TEST RESULT CERTIFICATION

Applicant's name..... : Senwa Global International, S.A. de C.V.
Address : Carretera Mexico-Toluca No. 5324 PB, Colonia El Yaqui Del.
Cuajimalpa de Morelos, C.P. 05320 Ciudad de Mexico, Mexico
Manufacturer's Name..... : Senwa Mobile China Ltd
Address : A611, Languang technology building, No. 27, Gaoxin North 6th Road,
songpingshan community, Xili street, Nanshan District, Shenzhen,
Guangdong Province
Product name : Mobile Phone
Model and/or type reference : SOSPIRO-A60L
Family Model: SOSPIRO-A60L-G
Test sample number S230712022010
Standards..... : FCC CFR 47 Part 22H, Part 24E, Part 27
Test procedure : ANSI C63.46:2015
ANSI/TIA-603-E-2016

This device described above has been tested by NTEK, and the test results show that the equipment under test (EUT) is in compliance with the FCC requirements. And it is applicable only to the tested sample identified in the report.

This report shall not be reproduced except in full, without the written approval of NTEK, this document may be altered or revised by NTEK, personal only, and shall be noted in the revision of the document.

Date of Test
Date (s) of performance of tests Jul 14, 2023 ~ Aug 03, 2023
Date of Issue Aug 04, 2023
Test Result..... Pass

Testing Engineer : [Signature]
(Allen Liu)

Authorized Signatory : [Signature]
(Alex Li)

TABLE OF CONTENTS

1. GENERAL INFORMATION	5
1.1 PRODUCT DESCRIPTION	5
1.2 RELATED SUBMITTAL(S) / GRANT (S)	6
1.3 TEST METHODOLOGY	6
1.4 TEST FACILITY	6
MEASUREMENT UNCERTAINTY	6
1.5 SPECIAL ACCESSORIES	6
1.6 WORST-CASE CONFIGURATION AND MODE	6
2. SYSTEM TEST CONFIGURATION	7
2.1 EUT CONFIGURATION	7
2.2 EUT EXERCISE	7
2.3 CONFIGURATION OF EUT SYSTEM	7
2.4 TEST SETUP	8
3. TEST AND MEASUREMENT EQUIPMENT	9
4. OUTPUT POWER	11
4.1 OUTPUT POWER MEASUREMENT	11
6. BANDEDGE AND EMISSION MASK	14
7. OUT OF BAND EMISSIONS	15
7.1 MEASUREMENT METHOD	16
8. RADIATED MEASUREMENT	17
8.1. RADIATED POWER (ERP & EIRP)	17
8.2 LTE BAND 2	18
8.3 LTE BAND 4	22
8.4 LTE BAND 5	26
8.5 LTE BAND 7	28

8.6 LTE BAND 13	30
8.7 LTE BAND 66	32
9. SPURIOUS RADIATION EMISSION	36
9.1 LTE BAND 2.....	38
9.2 LTE BAND 4.....	40
9.3 LTE BAND 5.....	42
9.4 LTE BAND 7.....	44
9.5 LTE BAND 13	46
9.6 LTE BAND 66	48
10. FREQUENCY STABILITY	50
10.1 LTE BAND 2	51
10.2 LTE BAND 4	53
10.3 LTE BAND 5	55
10.4 LTE BAND 7	57
10.5 LTE BAND 13	59
10.6 LTE BAND 66	61
11. PEAK-TO-AVERAGE RATIO.....	63
11.1 Description of the PAR Measurement.....	63
11.2 Measuring Instruments	63
11.3 Test Procedures.....	63
11.4 Test Setup.....	63

1. GENERAL INFORMATION

1.1 PRODUCT DESCRIPTION

A major technical description of EUT is described as following:

Product Designation:	Mobile Phone
Trade Mark	ACER
Model Name	SOSPIRO-A60L
Family Model	SOSPIRO-A60L-G
Model Difference	All models are the same circuit and RF module, except the model name and colour.
FCC ID:	2AZYA-A60L
Frequency Bands:	U.S. Bands: <input checked="" type="checkbox"/> LTE FDD Band 2, 4, 5, 7, 13, 66
Frequency Range:	LTE FDD Band 2 Uplink: 1850MHz-1910MHz, Downlink: 1930MHz-1990MHz; LTE FDD Band 4 Uplink: 1710MHz-1755MHz, Downlink: 2110MHz-2155MHz; LTE FDD Band 5 Uplink: 824MHz-849MHz, Downlink: 869MHz-894MHz; LTE-FDD Band 7 Uplink: 2500MHz-2570MHz, Downlink: 2620MHz-2690MHz; LTE FDD Band 13 Uplink: 777MHz-787MHz, Downlink: 746MHz-756MHz; LTE FDD Band 66 Uplink: 1710MHz-1780MHz, Downlink: 2110MHz-2200MHz;
Type of Modulation:	QPSK/16QAM
Antenna:	PIFA Antenna
Antenna gain:	Band 2:1 dBi; Band 4:0.8 dBi; Band 5:0.1 dBi; Band 7:1.3 dBi; Band 13:-0.3 dBi; Band 66:0.8 dBi;
Power Supply:	DC 3.8V/3000mAh from battery or DC 5V from Adapter.
Adapter:	Model: SGCH1000 Input: 100-240Vca 50/60Hz 0.2A Output: 5.0Vcc 1A
Extreme Vol. Limits:	DC 3.4V to DC 4.4V (Nominal DC 3.8V) (Note 1)
HW Version	sp9832e_1h10_go
SW Version	ACER_A60L_TELCEL_Ver01
** Note1: The High Voltage 4.4V and Low Voltage 3.4V was declared by manufacturer, The EUT couldn't be operate normally with higher or lower voltage.	

1.2 RELATED SUBMITTAL(S) / GRANT (S)

This submittal(s) (test report) is intended for **FCC ID: 2AZYA-A60L** filing to comply with the FCC Part 22H&24E &27.

1.3 TEST METHODOLOGY

The tests documented in this report were performed in accordance with ANSI/TIA-603-E-2016, FCC CFR 47 Part 2, Part 22, Part 24, Part 27 ,ANSI C63.46:2015.

1.4 TEST FACILITY

The test site used to collect the radiated data is located at:

ShenZhen NTEK Testing Technology Co., Ltd.

1&5/F, Building C, 1&2/F, Building E, Fenda Science Park, Sanwei Community, Hangcheng Street, Baoan District, Shenzhen ,Guangdong, China.

The test site is constructed and calibrated to meet the FCC requirements in documents ANSI C63.46:2015& ANSI C63.4: 2014.

FCC Registration No.:463705

IC Registration No.:9270A-1,

CNAS Registration No.:L5516

MEASUREMENT UNCERTAINTY

The reported uncertainty of measurement, where expended uncertainty U is based on a standard uncertainty multiplied by a coverage factor of k=2, providing a level of confidence of approximately 95 %.

No.	Item	Uncertainty
1	Measuring Uncertainty for a Level of Confidence of 95% (U = 2Uc(y))	2.5dB

1.5 SPECIAL ACCESSORIES

The battery and the charger, earphone supplied by the applicant were used as accessories and being tested with EUT intended for FCC grant together.

1.6 WORST-CASE CONFIGURATION AND MODE

The worst-case scenario for all measurements is based on the investigation results.

The device has LTE Bands of: Band 2, Band 4, Band 5, Band 7, Band 13, Band 66.

The RB Size was selected to measure for peak or average ERP and EIRP, which was based on the conducted power verification baseline data.

For the fundamental investigation of radiated emissions, the EUT is investigated for vertical and horizontal antenna orientations and X Y and Z orientations of the EUT alone. After the investigations the worst case was determined to be at X orientation for all LTE bands.

2. SYSTEM TEST CONFIGURATION

2.1 EUT CONFIGURATION

The EUT configuration for testing is installed on RF field strength measurement to meet the Commission's requirement and operating in a manner which intends to maximize its emission characteristics in a continuous normal application.

2.2 EUT EXERCISE

The Transmitter was operated in the maximum output power mode through Communication Tester. The TX frequency was fixed which was for the purpose of the measurements.

2.3 CONFIGURATION OF EUT SYSTEM

Table 2-1 Equipment Used in EUT System

Item	Equipment	Model No.	ID or Specification	Note
1	Mobile Phone	SOSPIRO-A60L	FCC ID: 2AZYA-A60L	EUT

*Note: All the accessories have been used during the test.
the following "EUT" in setup diagram means EUT system.*

2.4 TEST SETUP

For Radiated Test Cases

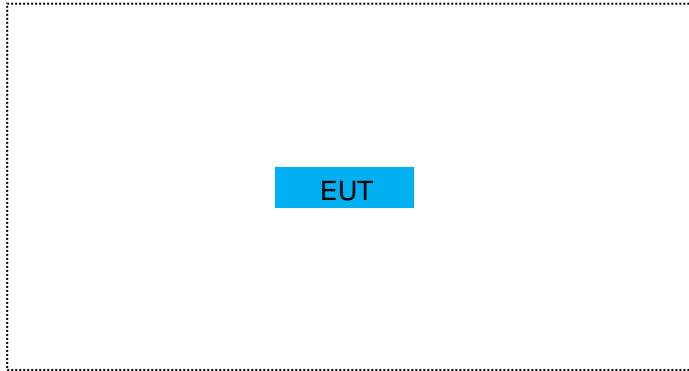

For Conducted Output Power

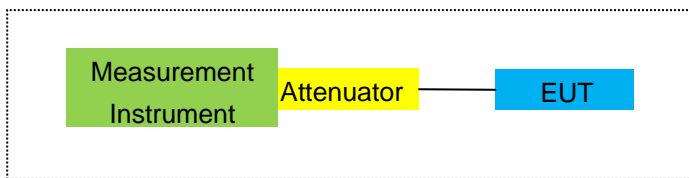

For Peak-to Average Ratio, Occupied Bandwidth, Conducted Band edge and Conducted Spurious Emission

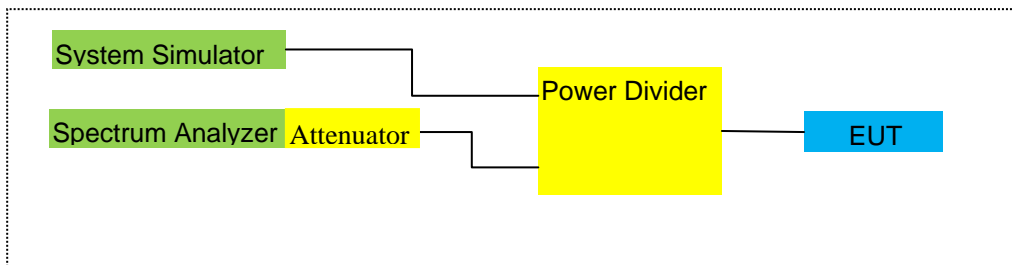

For Frequency Stability

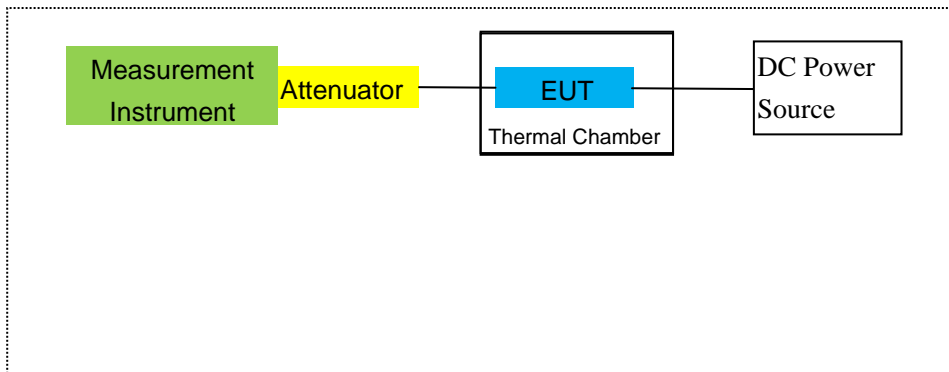

Note: EUT built-in battery-powered, the battery is fully-charged.

3. TEST AND MEASUREMENT EQUIPMENT

The following test and measurement equipment was utilized for the tests documented in this report:

Item	Kind of Equipment	Manufacturer	Type No.	Serial No.	Last calibration	Calibrated until	Calibration period
1	MXA Signal Analyzer	Agilent	N9020A	MY49100060	2023.05.29	2024.05.28	1 year
2	Test Receiver	R&S	ESPI	101318	2023.03.27	2024.03.26	1 year
3	Bilog Antenna	TESEQ	CBL6111D	31216	2023.03.27	2024.03.26	1 year
4	50Ω Coaxial Switch	Anritsu	MP59B	6200983705	2023.05.06	2026.05.05	3 year
5	Broadband Horn Antenna	SCHWARZBECK	BBHA 9120 D	2816	2023/1/12	2024/1/11	1 year
6	Broadband Horn Antenna	SCHWARZBECK	BBHA 9120 D	2817	2023/1/12	2024/1/11	1 year
7	Amplifier	EM	EM-30180	060538	2023.05.29	2024.05.28	1 year
8	Loop Antenna	ARA	PLA-1030/B	1029	2023.03.27	2024.03.26	1 year
9	Power Meter	R&S	NRVS	100696	2023.05.29	2024.05.28	1 year
10	Power Sensor	R&S	URV5-Z4	0395.1619.05	2023.03.27	2024.03.26	1 year
11	Test Cable	N/A	R-01	N/A	2022.06.17	2025.06.16	3 year
12	Test Cable	N/A	R-02	N/A	2022.06.17	2025.06.16	3 year
13	Test Cable	N/A	R-03	N/A	2022.06.17	2025.06.16	3 year
14	Test Receiver	R&S	ESCI	101160	2023.03.27	2024.03.26	1 year
15	LISN	R&S	ENV216	101313	2023.03.27	2024.03.26	1 year
16	LISN	EMCO	3816/2	00042990	2023.03.27	2024.03.26	1 year
17	50Ω Coaxial Switch	Anritsu	MP59B	6200264417	2023.03.27	2024.03.26	1 year
18	Passive Voltage Probe	R&S	ESH2-Z3	100196	2023.03.27	2024.03.26	1 year
19	Test Cable	N/A	C01	N/A	2023.05.06	2026.05.05	3 year
20	Test Cable	N/A	C02	N/A	2023.05.06	2026.05.05	3 year
21	Test Cable	N/A	C03	N/A	2023.05.06	2026.05.05	3 year
22	Attenuator	MCE	24-10-34	BN9258	2023.03.27	2024.03.26	1 year
23	Spectrum Analyzer	agilent	e4440a	us44300399	2023.03.27	2024.03.26	1 year
24	test receiver	R&S	ESCI	a0304218	2023.03.27	2024.03.26	1 year

25	Communication Tester	R&S	CMU200	A0304247	2023.05.29	2024.05.28	1 year
26	Thermal Chamber	Ten Billion	TTC-B3C	TBN-960502	2023.03.27	2024.03.26	1 year
27	DC Power Source	N/A	PS-6005D	20170402923	2023.05.06	2026.05.05	3 year
28	MXG Vector Signal Generator	Agilent	N5182A	MY47070317	2023.05.29	2024.05.28	1 year
29	Communication Tester	R&S	CMW500	148500	2023.05.29	2024.05.28	1 year
30	Log-Periodic Antenna	SCHWARZBECK	VULB 9162	584	2023/1/11	2024/1/10	1 year
31	Log-Periodic Antenna	SCHWARZBECK	VULB 9162	586	2023/1/11	2024/1/10	1 year
32	ESG Vector Signal Generator	Agilent	E4438C	MY45093347	2023/3/21	2024/3/20	1 year

Note: Each piece of equipment is scheduled for calibration once a year except the Test Cable& DC Power Source which is scheduled for calibration every 3 years.

4. OUTPUT POWER

4.1 OUTPUT POWER MEASUREMENT

LTE Measurement Procedure:

All LTE bands conducted power peak and average are obtained from the CMW500 telecommunication test set. The following tests were conducted according to the test requirements outlined in section 6.2 of the 3GPP TS36.101 specification.

UE Power Class: 3 (23 +/- 2dBm). The allowed Maximum Power Reduction (MPR) for the maximum output power due to higher order modulation and transmit bandwidth configuration (resource blocks) is specified in Table 6.2.3-1 of the 3GPP TS36.101.

Table 6.2.3-1: Maximum Power Reduction (MPR) for Power Class 3

Modulation	Channel bandwidth / Transmission bandwidth (RB)						MPR (dB)
	1.4 MHz	3.0 MHz	5 MHz	10 MHz	15 MHz	20 MHz	
QPSK	> 5	> 4	> 8	> 12	> 16	> 18	≤ 1
16 QAM	≤ 5	≤ 4	≤ 8	≤ 12	≤ 16	≤ 18	≤ 1
16 QAM	> 5	> 4	> 8	> 12	> 16	> 18	≤ 2

The allowed A-MPR values specified below in Table 6.2.4.-1 of 3GPP TS36.101 are in addition to the allowed MPR requirements. All the measurements below were performed with A-MPR disabled, by using Network Signaling Value of "NS_01".3

Table 6.2.4-1: Additional Maximum Power Reduction (A-MPR)

Network Signalling value	Requirements (sub-clause)	E-UTRA Band	Channel bandwidth (MHz)	Resources Blocks (N_{RB})	A-MPR (dB)
NS_01	6.6.2.1.1	Table 5.5-1	1.4, 3, 5, 10, 15, 20	Table 5.6-1	NA
NS_03	6.6.2.2.1	2, 4, 10, 23, 25, 35, 36	3	>5	≤ 1
			5	>6	≤ 1
			10	>6	≤ 1
			15	>8	≤ 1
			20	>10	≤ 1
NS_04	6.6.2.2.2	41	5	>6	≤ 1
			10, 15, 20	See Table 6.2.4-4	
NS_05	6.6.3.3.1	1	10,15,20	≥ 50	≤ 1
NS_06	6.6.2.2.3	12, 13, 14, 17	1.4, 3, 5, 10	Table 5.6-1	n/a
NS_07	6.6.2.2.3	13	10	Table 6.2.4-2	Table 6.2.4-2
	6.6.3.3.2				
NS_08	6.6.3.3.3	19	10, 15	> 44	≤ 3
NS_09	6.6.3.3.4	21	10, 15	> 40	≤ 1
				> 55	≤ 2
NS_10		20	15, 20	Table 6.2.4-3	Table 6.2.4-3
NS_11	6.6.2.2.1	23 ¹	1.4, 3, 5, 10	Table 6.2.4-5	Table 6.2.4-5
..					
NS_32	-	-	-	-	-

Note 1: Applies to the lower block of Band 23, i.e. a carrier placed in the 2000-2010 MHz region.

Test data reference attachment.

5. OCCUPIED BANDWIDTH

RULE PART(S)

FCC: §2.1049

LIMITS

For reporting purposes only

TEST PROCEDURE

The transmitter output was connected to a calibrated coaxial cable and coupler, the other end of which was connected to a spectrum analyzer. The occupied bandwidth was measured with the spectrum analyzer at the low, middle and high channel in each band. The -26dB bandwidth was also measured and recorded.

MODES TESTED

- LTE Band 2
- LTE Band 4
- LTE Band 5
- LTE Band 7
- LTE Band 13
- LTE Band 66

RESULTS

PASS

Test data reference attachment.

6. BANDEDGE AND EMISSION MASK

RULE PART(S)

FCC: §2.1051, §22.917(a), §24.238(a), §27.53(c)(g)(h)(m)

FCC: §2.1046, §22.913, §24.232

LIMITS

The minimum permissible attenuation level of any spurious emission is $43 + \log_{10}(P[\text{Watts}])$, where P is the transmitter power in Watts.

The minimum permissible attenuation level for Band 7 is as following.

Per 27.53(g) for operations in the 698-746 MHz band, in the 100 kHz bands immediately outside and adjacent to the frequency block a resolution bandwidth of at least 30 kHz may be employed to demonstrate compliance with the out-of-band emissions limit.

Per 27.53(c.5) for operations in the 776-788 MHz band, in the 100 kHz bands immediately outside and adjacent to the frequency block a resolution bandwidth of at least 30 kHz may be employed to demonstrate compliance with the out-of-band emissions limit.

For all plots showing emissions in the 763 – 775MHz and 793 – 805MHz band, the FCC limit per 27.53(c.4) is $65 + 10\log_{10}(P) = -35\text{dBm}$ in a 6.25kHz bandwidth.

Per 27.53(m) for operations in the BRS/EBS bands, the attenuation factor shall be not less than $40 + 10 \log (P)$ dB on all frequencies between the channel edge and 5 megahertz from the channel edge, $43 + 10 \log (P)$ dB on all frequencies between 5 megahertz and X megahertz from the channel edge, and $55 + 10 \log (P)$ dB on all frequencies more than X megahertz from the channel edge, where X is the greater of 6 megahertz or the actual emission bandwidth.

TEST PROCEDURE

The transmitter output was connected to a CMW500Test Set and configured to operate at maximum power. The band edge emissions were measured at the required operating frequencies in each band on the Spectrum Analyzer.

For each band edge measurement:

Set the spectrum analyzer span to include the block edge frequency

Set a marker to point the corresponding band edge frequency in each test case.

Set display line

Set resolution bandwidth to at least 1% of emission bandwidth.

MODES TESTED

- LTE Band2/4/5/7/13/66

RESULTS

Test data reference attachment.

Note: Both QPSK and 16QAM has been tested, the worst case is QPSK mode, the report just reported the worst case.

7. OUT OF BAND EMISSIONS

RULE PART(S)

FCC: §2.1051, §22.917(a), §24.238(a), §27.53(c)(g)(h)(m)

LIMITS

The minimum permissible attenuation level of any spurious emission is $43 + \log_{10}(P[\text{Watts}])$, where P is the transmitter power in Watts.

The minimum permissible attenuation level for Band 7 is as following.

Per 27.53(g) for operations in the 698-746 MHz band, in the 100 kHz bands immediately outside and adjacent to the frequency block a resolution bandwidth of at least 30 kHz may be employed to demonstrate compliance with the out-of-band emissions limit.

Per 27.53(c.5) for operations in the 776-788 MHz band, in the 100 kHz bands immediately outside and adjacent to the frequency block a resolution bandwidth of at least 30 kHz may be employed to demonstrate compliance with the out-of-band emissions limit.

For all plots showing emissions in the 763 – 775MHz and 793 – 805MHz band, the FCC limit per 27.53(c.4) is $65 + 10\log_{10}(P) = -35\text{dBm}$ in a 6.25kHz bandwidth.

Per 27.53(m) for operations in the BRS/EBS bands, the attenuation factor shall be not less than $40 + 10 \log (P)$ dB on all frequencies between the channel edge and 5 megahertz from the channel edge, $43 + 10 \log (P)$ dB on all frequencies between 5 megahertz and X megahertz from the channel edge, and $55 + 10 \log (P)$ dB on all frequencies more than X megahertz from the channel edge, where X is the greater of 6 megahertz or the actual emission bandwidth.

TEST PROCEDURE

The RF output of the transmitter was connected to a spectrum analyzer through a calibrated coaxial cable. Sufficient scans were taken to show the out-of-band Emissions, if any, up to 10th harmonic. Multiple sweeps were recorded in maximum hold mode using a peak detector to ensure that the worst-case emissions were caught.

For each out of band emissions measurement:

- Set display line
- Set RBW & VBW to 100 kHz for the measurement below 1 GHz, and 1 MHz for the measurement above 1 GHz.

MODES TESTED

- LTE Band 2
- LTE Band 4
- LTE Band 5
- LTE Band 7
- LTE Band 13
- LTE Band 66

7.1 MEASUREMENT METHOD

The test set up and general procedure is similar to conducted peak output power test. Only different for setting the measurement configuration of the measuring instrument of Spectrum Analyzer.

Test data reference attachment.

Note: Both QPSK and 16QAM has been tested, the worst case is QPSK mode, the report just reported the worst case.

8. RADIATED MEASUREMENT

8.1. RADIATED POWER (ERP & EIRP)

RULE PART(S)

FCC: §2.1046, §22.913(a)(2), §24.232(c) and §27.50 (h)(2), (b)(10), (c)(10), (d)(4)

LIMITS:

22.913(a) (2)- The ERP of mobile transmitters and auxiliary test transmitters must not exceed 7 Watts.
24.232 (c) Mobile and portable stations are limited to 2 watts EIRP.
27.50 (c) (10) the following power and antenna height requirements apply to stations transmitting in the 698–746 MHz band, the portable stations (hand-held devices) are limited to 3 watts ERP.
27.50 (b)(10) Portable stations (hand-held devices) transmitting in the 746–757 MHz, 758–763 MHz, 776–793 MHz, and 805–806 MHz bands are limited to 3 watts ERP.
27.50 (d)(4) The following power and antenna height requirements apply to stations transmitting in the 1710–1755 MHz and 2110–2155 MHz bands: Fixed, mobile, and portable (hand-held) stations operating in the 1710–1755 MHz band are limited to 1 watt EIRP.
27.50 (h)(2) Mobile and other user stations in the 2500–2570 MHz and 2620–2690 MHz bands. Mobile stations are limited to 2.0 watts EIRP. All user stations are limited to 2.0 watts transmitter output power.

TEST PROCEDURE

ANSI/TIA-603-E Clause 2.2.17

KDB 971168 v02r01 RF power output using broadband peak and average power meter method.

KDB 971168 D01 Power Meas License Digital Systems v02r01, “Measurement Guidance for Certification of Licensed Digital Transmitters”

MODES TESTED

- LTE Band 2
- LTE Band 4
- LTE Band 5
- LTE Band 7
- LTE Band 13
- LTE Band 66

RESULTS

Pass

8.2 LTE BAND 2

Radiated Power (EIRP) for Band 2									
Mode	RB/RB SIZE	Frequency	Result						Conclusion
			SG Level (dBm)	Cable Loss (dBm)	Antenna Factor (dB)	Max. EIRP Average (dBm)	Max. EIRP Average (mW)	Polarization Of Max. ERP	
1.4MHz Band QPSK	1/#Mid	1850.7	-3.13	3.76	28.24	21.35	136.458	Horizontal	Pass
		1880	-2.94	3.91	28.22	21.37	137.088	Horizontal	Pass
		1909.3	-2.85	3.93	28.20	21.42	138.676	Horizontal	Pass
3.0MHz Band QPSK	1/#Mid	1851.5	-3.19	3.77	28.23	21.27	133.968	Horizontal	Pass
		1880	-3.04	3.91	28.24	21.29	134.586	Horizontal	Pass
		1908.5	-2.91	3.94	28.25	21.40	138.038	Horizontal	Pass
5.0MHz Band QPSK	1/#Mid	1852.5	-3.08	3.77	28.31	21.46	139.959	Horizontal	Pass
		1880	-2.70	3.91	28.22	21.61	144.877	Horizontal	Pass
		1907.5	-2.63	3.94	28.20	21.63	145.546	Horizontal	Pass
10.0MHz Band QPSK	1/#Mid	1855	-2.94	3.79	28.33	21.60	144.544	Horizontal	Pass
		1880	-2.64	3.95	28.22	21.63	145.546	Horizontal	Pass
		1905	-2.53	3.97	28.19	21.69	147.571	Horizontal	Pass
15.0MHz Band QPSK	1/#Mid	1857.5	-2.90	3.79	28.34	21.65	146.218	Horizontal	Pass
		1880	-2.69	3.95	28.22	21.58	143.880	Horizontal	Pass
		1902.5	-2.55	3.97	28.18	21.66	146.555	Horizontal	Pass
20.0MHz Band QPSK	1/#Mid	1860	-2.89	3.81	28.35	21.65	146.218	Horizontal	Pass
		1880	-2.56	3.96	28.22	21.70	147.911	Horizontal	Pass
		1900	-2.50	4.00	28.16	21.66	146.555	Horizontal	Pass
1.4MHz Band QPSK	1/#Mid	1850.7	-4.05	3.76	28.24	20.43	110.408	Vertical	Pass
		1880	-3.39	3.91	28.22	20.92	123.595	Vertical	Pass
		1909.3	-3.68	3.93	28.20	20.59	114.551	Vertical	Pass
3.0MHz Band QPSK	1/#Mid	1851.5	-4.10	3.77	28.23	20.36	108.643	Vertical	Pass
		1880	-3.28	3.91	28.24	21.05	127.350	Vertical	Pass
		1908.5	-3.89	3.94	28.25	20.42	110.154	Vertical	Pass
5.0MHz Band QPSK	1/#Mid	1852.5	-4.23	3.77	28.31	20.31	107.399	Vertical	Pass
		1880	-3.80	3.91	28.22	20.51	112.460	Vertical	Pass
		1907.5	-3.27	3.94	28.20	20.99	125.603	Vertical	Pass
10.0MHz Band QPSK	1/#Mid	1855	-3.62	3.79	28.33	20.92	123.595	Vertical	Pass
		1880	-3.79	3.95	28.22	20.48	111.686	Vertical	Pass
		1905	-3.68	3.97	28.19	20.54	113.240	Vertical	Pass

15.0MHz		1857.5	-3.90	3.79	28.34	20.65	116.145	Vertical	Pass
Band	1/#Mid	1880	-3.21	3.95	28.22	21.06	127.644	Vertical	Pass
QPSK		1902.5	-3.55	3.97	28.18	20.66	116.413	Vertical	Pass
20.0MHz		1860	-3.58	3.81	28.35	20.96	124.738	Vertical	Pass
Band	1/#Mid	1880	-3.55	3.96	28.22	20.71	117.761	Vertical	Pass
QPSK		1900	-3.81	4.00	28.16	20.35	108.393	Vertical	Pass

Note:

SG Level= Signal generator output

Max. EIRP Average (dBm)= Factor Gain(dB) + SG Level (dBm)- Cable Loss(dBm)

Factor Gain(dB)=Antenna Gain(dB) + Amplifier Factor (dB)

Radiated Power (EIRP) for Band 2									
Mode	RB/RB SIZE	Frequency	Result						Conclusion
			SG Level (dBm)	Cable Loss (dBm)	Antenna Factor (dB)	Max. EIRP Average (dBm)	Max. EIRP Average (mW)	Polarization Of Max. ERP	
1.4MHz Band 16 QAM	1/#Mid	1850.7	-4.25	3.76	28.24	20.23	105.439	Horizontal	Pass
		1880	-3.72	3.91	28.22	20.59	114.551	Horizontal	Pass
		1909.3	-3.65	3.93	28.20	20.62	115.345	Horizontal	Pass
3.0MHz Band 16 QAM	1/#Mid	1851.5	-3.75	3.77	28.23	20.71	117.761	Horizontal	Pass
		1880	-3.83	3.91	28.24	20.50	112.202	Horizontal	Pass
		1908.5	-4.04	3.94	28.25	20.27	106.414	Horizontal	Pass
5.0MHz Band 16 QAM	1/#Mid	1852.5	-3.69	3.77	28.31	20.85	121.619	Horizontal	Pass
		1880	-3.60	3.91	28.22	20.71	117.761	Horizontal	Pass
		1907.5	-3.28	3.94	28.20	20.98	125.314	Horizontal	Pass
10.0MHz Band 16 QAM	1/#Mid	1855	-3.74	3.79	28.33	20.80	120.226	Horizontal	Pass
		1880	-3.73	3.95	28.22	20.54	113.240	Horizontal	Pass
		1905	-3.20	3.97	28.19	21.02	126.474	Horizontal	Pass
15.0MHz Band 16 QAM	1/#Mid	1857.5	-3.72	3.79	28.34	20.83	121.060	Horizontal	Pass
		1880	-3.51	3.95	28.22	20.76	119.124	Horizontal	Pass
		1902.5	-3.47	3.97	28.18	20.74	118.577	Horizontal	Pass
20.0MHz Band 16 QAM	1/#Mid	1860	-3.61	3.81	28.35	20.93	123.880	Horizontal	Pass
		1880	-3.31	3.96	28.22	20.95	124.451	Horizontal	Pass
		1900	-3.13	4.00	28.16	21.03	126.765	Horizontal	Pass
1.4MHz Band 16 QAM	1/#Mid	1850.7	-5.16	3.76	28.24	19.32	85.507	Vertical	Pass
		1880	-5.19	3.91	28.22	19.12	81.658	Vertical	Pass
		1909.3	-5.17	3.93	28.20	19.10	81.283	Vertical	Pass
3.0MHz Band 16 QAM	1/#Mid	1851.5	-4.58	3.77	28.23	19.88	97.275	Vertical	Pass
		1880	-5.05	3.91	28.24	19.28	84.723	Vertical	Pass
		1908.5	-5.22	3.94	28.25	19.09	81.096	Vertical	Pass
5.0MHz Band 16 QAM	1/#Mid	1852.5	-4.50	3.77	28.31	20.04	100.925	Vertical	Pass
		1880	-4.39	3.91	28.22	19.92	98.175	Vertical	Pass
		1907.5	-5.13	3.94	28.20	19.13	81.846	Vertical	Pass
10.0MHz Band 16 QAM	1/#Mid	1855	-5.39	3.79	28.33	19.15	82.224	Vertical	Pass
		1880	-4.46	3.95	28.22	19.81	95.719	Vertical	Pass
		1905	-4.19	3.97	28.19	20.03	100.693	Vertical	Pass
15.0MHz Band 16 QAM	1/#Mid	1857.5	-5.04	3.79	28.34	19.51	89.331	Vertical	Pass
		1880	-4.78	3.95	28.22	19.49	88.920	Vertical	Pass
		1902.5	-4.88	3.97	28.18	19.33	85.704	Vertical	Pass

20.0MHz		1860	-5.14	3.81	28.35	19.40	87.096	Vertical	Pass
Band 16	1/#Mid	1880	-4.76	3.96	28.22	19.50	89.125	Vertical	Pass
QAM		1900	-4.12	4.00	28.16	20.04	100.925	Vertical	Pass

Note:

SG Level= Signal generator output

Max. EIRP Average (dBm)= Factor Gain (dB) + SG Level (dBm)- Cable Loss(dBm)

Factor Gain(dB)=Antenna Gain(dB) + Amplifier Factor (dB)

8.3 LTE BAND 4

Radiated Power (EIRP) for Band 4										
Mode	RB/RB SIZE	Frequency	Result						Polarization Of Max. ERP	Conclusion
			SG Level	Cable Loss (dBm)	Antenna Factor (dB)	Max. EIRP	Max. EIRP			
			(dBm)			Average	Average			
						(dBm)	(mW)			
1.4MHz Band QPSK	1/#Mid	1710.7	-3.04	3.12	27.58	21.42	138.676	Horizontal	Pass	
		1732.5	-3.03	3.27	27.61	21.31	135.207	Horizontal	Pass	
		1754.3	-3.01	3.29	27.63	21.33	135.831	Horizontal	Pass	
3.0MHz Band QPSK	1/#Mid	1711.5	-3.21	3.13	27.61	21.27	133.968	Horizontal	Pass	
		1732.5	-3.13	3.27	27.61	21.21	132.130	Horizontal	Pass	
		1753.5	-3.05	3.30	27.62	21.27	133.968	Horizontal	Pass	
5.0MHz Band QPSK	1/#Mid	1712.5	-2.98	3.13	27.63	21.52	141.906	Horizontal	Pass	
		1732.5	-2.88	3.27	27.61	21.46	139.959	Horizontal	Pass	
		1752.5	-2.76	3.30	27.60	21.54	142.561	Horizontal	Pass	
10.0MHz Band QPSK	1/#Mid	1715	-2.92	3.15	27.64	21.57	143.549	Horizontal	Pass	
		1732.5	-2.69	3.31	27.61	21.61	144.877	Horizontal	Pass	
		1750	-2.71	3.33	27.59	21.55	142.889	Horizontal	Pass	
15.0MHz Band QPSK	1/#Mid	1717.5	-2.93	3.15	27.65	21.57	143.549	Horizontal	Pass	
		1732.5	-2.77	3.31	27.61	21.53	142.233	Horizontal	Pass	
		1747.5	-2.71	3.33	27.57	21.53	142.233	Horizontal	Pass	
20.0MHz Band QPSK	1/#Mid	1720	-2.87	3.17	27.66	21.62	145.211	Horizontal	Pass	
		1732.5	-2.70	3.32	27.61	21.59	144.212	Horizontal	Pass	
		1745	-2.64	3.36	27.56	21.56	143.219	Horizontal	Pass	
1.4MHz Band QPSK	1/#Mid	1710.7	-3.96	3.12	27.58	20.50	112.202	Vertical	Pass	
		1732.5	-3.77	3.27	27.61	20.57	114.025	Vertical	Pass	
		1754.3	-4.18	3.29	27.63	20.16	103.753	Vertical	Pass	
3.0MHz Band QPSK	1/#Mid	1711.5	-3.64	3.13	27.61	20.84	121.339	Vertical	Pass	
		1732.5	-3.27	3.27	27.61	21.07	127.938	Vertical	Pass	
		1753.5	-3.49	3.30	27.62	20.83	121.060	Vertical	Pass	
5.0MHz Band QPSK	1/#Mid	1712.5	-3.83	3.13	27.63	20.67	116.681	Vertical	Pass	
		1732.5	-3.46	3.27	27.61	20.88	122.462	Vertical	Pass	
		1752.5	-3.74	3.30	27.60	20.56	113.763	Vertical	Pass	
10.0MHz Band QPSK	1/#Mid	1715	-4.36	3.15	27.64	20.13	103.039	Vertical	Pass	
		1732.5	-3.91	3.31	27.61	20.39	109.396	Vertical	Pass	
		1750	-3.42	3.33	27.59	20.84	121.339	Vertical	Pass	
15.0MHz	1/#Mid	1717.5	-3.53	3.15	27.65	20.97	125.026	Vertical	Pass	

Band		1732.5	-3.66	3.31	27.61	20.64	115.878	Vertical	Pass
QPSK		1747.5	-3.59	3.33	27.57	20.65	116.145	Vertical	Pass
20.0MHz	1/#Mid	1720	-3.68	3.17	27.66	20.81	120.504	Vertical	Pass
Band		1732.5	-4.05	3.32	27.61	20.24	105.682	Vertical	Pass
QPSK		1745	-4.04	3.36	27.56	20.16	103.753	Vertical	Pass

Note:

SG Level= Signal generator output

Max. EIRP Average (dBm)= Factor Gain (dB)+ SG Level (dBm)- Cable Loss(dBm)

Factor Gain(dB)=Antenna Gain(dB) + Amplifier Factor (dB)

Radiated Power (EIRP) for Band 4									
Mode	RB/RB SIZE	Frequency	Result						Conclusion
			SG Level	Cable Loss	Antenna Factor	Max. EIRP	Max. EIRP	Polarization Of Max. ERP	
			(dBm)			Average	Average		
				(dBm)	(dB)	(dBm)	(mW)		
1.4MHz Band 16 QAM	1/#Mid	1710.7	-3.85	3.12	27.58	20.61	115.080	Horizontal	Pass
		1732.5	-3.70	3.27	27.61	20.64	115.878	Horizontal	Pass
		1754.3	-3.70	3.29	27.63	20.64	115.878	Horizontal	Pass
3.0MHz Band 16 QAM	1/#Mid	1711.5	-3.79	3.13	27.61	20.69	117.220	Horizontal	Pass
		1732.5	-3.92	3.27	27.61	20.42	110.154	Horizontal	Pass
		1753.5	-4.14	3.30	27.62	20.18	104.232	Horizontal	Pass
5.0MHz Band 16 QAM	1/#Mid	1712.5	-3.62	3.13	27.63	20.88	122.462	Horizontal	Pass
		1732.5	-3.58	3.27	27.61	20.76	119.124	Horizontal	Pass
		1752.5	-3.27	3.30	27.60	21.03	126.765	Horizontal	Pass
10.0MHz Band 16 QAM	1/#Mid	1715	-3.69	3.15	27.64	20.80	120.226	Horizontal	Pass
		1732.5	-3.88	3.31	27.61	20.42	110.154	Horizontal	Pass
		1750	-3.26	3.33	27.59	21.00	125.893	Horizontal	Pass
15.0MHz Band 16 QAM	1/#Mid	1717.5	-3.49	3.15	27.65	21.01	126.183	Horizontal	Pass
		1732.5	-3.55	3.31	27.61	20.75	118.850	Horizontal	Pass
		1747.5	-3.57	3.33	27.57	20.67	116.681	Horizontal	Pass
20.0MHz Band 16 QAM	1/#Mid	1720	-3.44	3.17	27.66	21.05	127.350	Horizontal	Pass
		1732.5	-3.45	3.32	27.61	20.84	121.339	Horizontal	Pass
		1745	-3.26	3.36	27.56	20.94	124.165	Horizontal	Pass
1.4MHz Band 16 QAM	1/#Mid	1710.7	-4.56	3.12	27.58	19.90	97.724	Vertical	Pass
		1732.5	-5.04	3.27	27.61	19.30	85.114	Vertical	Pass
		1754.3	-4.57	3.29	27.63	19.77	94.842	Vertical	Pass
3.0MHz Band 16 QAM	1/#Mid	1711.5	-4.44	3.13	27.61	20.04	100.925	Vertical	Pass
		1732.5	-4.27	3.27	27.61	20.07	101.625	Vertical	Pass
		1753.5	-5.23	3.30	27.62	19.09	81.096	Vertical	Pass
5.0MHz Band 16 QAM	1/#Mid	1712.5	-4.56	3.13	27.63	19.94	98.628	Vertical	Pass
		1732.5	-5.17	3.27	27.61	19.17	82.604	Vertical	Pass
		1752.5	-4.52	3.30	27.60	19.78	95.060	Vertical	Pass
10.0MHz Band 16 QAM	1/#Mid	1715	-5.00	3.15	27.64	19.49	88.920	Vertical	Pass
		1732.5	-4.34	3.31	27.61	19.96	99.083	Vertical	Pass
		1750	-4.49	3.33	27.59	19.77	94.842	Vertical	Pass
15.0MHz Band 16 QAM	1/#Mid	1717.5	-4.92	3.15	27.65	19.58	90.782	Vertical	Pass
		1732.5	-4.68	3.31	27.61	19.62	91.622	Vertical	Pass
		1747.5	-4.90	3.33	27.57	19.34	85.901	Vertical	Pass

20.0MHz		1720	-4.66	3.17	27.66	19.83	96.161	Vertical	Pass
Band 16	1/#Mid	1732.5	-4.22	3.32	27.61	20.07	101.625	Vertical	Pass
QAM		1745	-5.03	3.36	27.56	19.17	82.604	Vertical	Pass

Note:

SG Level= Signal generator output

Max. EIRP Average (dBm)= Factor Gain (dB)+ SG Level (dBm)- Cable Loss(dBm)

Factor Gain(dB)=Antenna Gain(dB) + Amplifier Factor (dB)

8.4 LTE BAND 5

Radiated Power (ERP) for Band 5											
Mode	RB/RB SIZE	Frequency	Result							Polarization Of Max. ERP	Conclusion
			SG Level	Cable Loss	Antenna Factor	Correction	Max. EIRP	Max. EIRP			
			(dBm)	(dBm)	(dB)	(dB)	Average	Average			
							(dBm)	(mW)			
1.4MHz	Band QPSK	824.7	6.26	2.01	19.68	2.15	21.78	150.661	Horizontal	Pass	
		836.5	6.14	2.01	19.77	2.15	21.75	149.624	Horizontal	Pass	
		848.3	5.94	2.02	19.82	2.15	21.59	144.212	Horizontal	Pass	
3.0MHz	Band QPSK	825.5	6.03	2.01	19.70	2.15	21.57	143.549	Horizontal	Pass	
		836.5	5.93	2.01	19.77	2.15	21.54	142.561	Horizontal	Pass	
		847.5	5.80	2.02	19.81	2.15	21.44	139.316	Horizontal	Pass	
5.0MHz	Band QPSK	826.5	6.31	2.01	19.71	2.15	21.86	153.462	Horizontal	Pass	
		836.5	6.19	2.01	19.77	2.15	21.80	151.356	Horizontal	Pass	
		846.5	6.03	2.02	19.79	2.15	21.65	146.218	Horizontal	Pass	
10.0MHz	Band QPSK	829	6.33	2.01	19.73	2.15	21.90	154.882	Horizontal	Pass	
		836.5	6.28	2.01	19.77	2.15	21.89	154.525	Horizontal	Pass	
		844	6.18	2.02	19.78	2.15	21.79	151.008	Horizontal	Pass	
1.4MHz	Band QPSK	824.7	4.88	2.01	19.68	2.15	20.40	109.648	Vertical	Pass	
		836.5	5.28	2.01	19.77	2.15	20.89	122.744	Vertical	Pass	
		848.3	5.35	2.02	19.82	2.15	21.00	125.893	Vertical	Pass	
3.0MHz	Band QPSK	825.5	5.26	2.01	19.70	2.15	20.80	120.226	Vertical	Pass	
		836.5	4.79	2.01	19.77	2.15	20.40	109.648	Vertical	Pass	
		847.5	4.73	2.02	19.81	2.15	20.37	108.893	Vertical	Pass	
5.0MHz	Band QPSK	826.5	5.24	2.01	19.71	2.15	20.79	119.950	Vertical	Pass	
		836.5	4.51	2.01	19.77	2.15	20.12	102.802	Vertical	Pass	
		846.5	4.64	2.02	19.79	2.15	20.26	106.170	Vertical	Pass	
10.0MHz	Band QPSK	829	4.53	2.01	19.73	2.15	20.10	102.329	Vertical	Pass	
		836.5	5.22	2.01	19.77	2.15	20.83	121.060	Vertical	Pass	
		844	4.68	2.02	19.78	2.15	20.29	106.905	Vertical	Pass	

Radiated Power (ERP) for Band 5

Radiated Power (ERP) for Band 5										
Mode	RB/RB SIZE	Frequency	Result							Conclusion
			SG Level	Cable Loss	Antenna Factor	Correction	Max. EIRP	Max. EIRP	Polarization	
			(dBm)	(dBm)	(dB)	(dB)	Average	Average	Of Max. ERP	
							(dBm)	(mW)		
1.4MHz Band 16 QAM	3/#Mid	824.7	5.41	2.01	19.68	2.15	20.93	123.880	Horizontal	Pass
		836.5	5.34	2.01	19.77	2.15	20.95	124.451	Horizontal	Pass
		848.3	5.18	2.02	19.82	2.15	20.83	121.060	Horizontal	Pass
3.0MHz Band 16 QAM	1/#Mid	825.5	5.49	2.01	19.70	2.15	21.03	126.765	Horizontal	Pass
		836.5	5.20	2.01	19.77	2.15	20.81	120.504	Horizontal	Pass
		847.5	4.68	2.02	19.81	2.15	20.32	107.647	Horizontal	Pass
5.0MHz Band 16 QAM	1/#Mid	826.5	5.81	2.01	19.71	2.15	21.36	136.773	Horizontal	Pass
		836.5	5.58	2.01	19.77	2.15	21.19	131.522	Horizontal	Pass
		846.5	5.33	2.02	19.79	2.15	20.95	124.451	Horizontal	Pass
10.0MHz Band 16 QAM	1/#Mid	829	5.81	2.01	19.73	2.15	21.38	137.404	Horizontal	Pass
		836.5	5.53	2.01	19.77	2.15	21.14	130.017	Horizontal	Pass
		844	5.07	2.02	19.78	2.15	20.68	116.950	Horizontal	Pass
1.4MHz Band 16 QAM	1/#Mid	824.7	4.33	2.01	19.68	2.15	19.85	96.605	Vertical	Pass
		836.5	3.48	2.01	19.77	2.15	19.09	81.096	Vertical	Pass
		848.3	4.57	2.02	19.82	2.15	20.22	105.196	Vertical	Pass
3.0MHz Band 16 QAM	1/#Mid	825.5	4.56	2.01	19.70	2.15	20.10	102.329	Vertical	Pass
		836.5	4.83	2.01	19.77	2.15	20.44	110.662	Vertical	Pass
		847.5	4.13	2.02	19.81	2.15	19.77	94.842	Vertical	Pass
5.0MHz Band 16 QAM	1/#Mid	826.5	4.26	2.01	19.71	2.15	19.81	95.719	Vertical	Pass
		836.5	4.28	2.01	19.77	2.15	19.89	97.499	Vertical	Pass
		846.5	3.76	2.02	19.79	2.15	19.38	86.696	Vertical	Pass
10.0MHz Band 16 QAM	1/#Mid	829	5.04	2.01	19.73	2.15	20.61	115.080	Vertical	Pass
		836.5	5.18	2.01	19.77	2.15	20.79	119.950	Vertical	Pass
		844	4.46	2.02	19.78	2.15	20.07	101.625	Vertical	Pass

Note:

ERP=EIRP-2.15

SG Level= Signal generator output

Max. EIRP Average (dBm)= Factor Gain (dB)+ SG Level (dBm)- Cable Loss(dBm)

Factor Gain(dB)=Antenna Gain(dB) + Amplifier Factor (dB)

8.5 LTE BAND 7

Radiated Power (EIRP) for Band 7									
Mode	RB/RB SIZE	Frequency	Result						Conclusion
			SG Level	Cable Loss (dBm)	Antenna Factor (dB)	Max. EIRP	Max. EIRP	Polarization Of Max. ERP	
			(dBm)			Average	Average		
						(dBm)	(mW)		
5.0MHz Band QPSK	1/#Mid	2502.5	-1.32	4.54	27.75	21.89	154.525	Horizontal	Pass
		2535	-1.15	4.69	27.72	21.88	154.170	Horizontal	Pass
		2567.5	-1.08	4.71	27.71	21.92	155.597	Horizontal	Pass
10.0MHz Band QPSK	1/#Mid	2505	-1.25	4.55	27.76	21.96	157.036	Horizontal	Pass
		2535	-1.06	4.69	27.72	21.97	157.398	Horizontal	Pass
		2565	-0.98	4.72	27.70	22.00	158.489	Horizontal	Pass
15.0MHz Band QPSK	1/#Mid	2507.5	-1.26	4.55	27.77	21.96	157.036	Horizontal	Pass
		2535	-1.12	4.69	27.72	21.91	155.239	Horizontal	Pass
		2562.5	-1.02	4.72	27.69	21.95	156.675	Horizontal	Pass
20.0MHz Band QPSK	1/#Mid	2510	-1.20	4.57	27.78	22.01	158.855	Horizontal	Pass
		2535	-1.02	4.73	27.72	21.97	157.398	Horizontal	Pass
		2560	-0.98	4.75	27.68	21.95	156.675	Horizontal	Pass
5.0MHz Band QPSK	1/#Mid	2502.5	-2.63	4.54	27.75	20.58	114.288	Vertical	Pass
		2535	-2.18	4.69	27.72	20.85	121.619	Vertical	Pass
		2567.5	-2.00	4.71	27.71	21.00	125.893	Vertical	Pass
10.0MHz Band QPSK	1/#Mid	2505	-2.70	4.55	27.76	20.51	112.460	Vertical	Pass
		2535	-2.38	4.69	27.72	20.65	116.145	Vertical	Pass
		2565	-1.95	4.72	27.70	21.03	126.765	Vertical	Pass
15.0MHz Band QPSK	1/#Mid	2507.5	-3.06	4.55	27.77	20.16	103.753	Vertical	Pass
		2535	-2.39	4.69	27.72	20.64	115.878	Vertical	Pass
		2562.5	-2.81	4.72	27.69	20.16	103.753	Vertical	Pass
20.0MHz Band QPSK	1/#Mid	2510	-2.59	4.57	27.78	20.62	115.345	Vertical	Pass
		2535	-2.32	4.73	27.72	20.67	116.681	Vertical	Pass
		2560	-2.05	4.75	27.68	20.88	122.462	Vertical	Pass

Radiated Power (EIRP) for Band 7									
Mode	RB/RB SIZE	Frequency	Result						Conclusion
			SG Level	Cable Loss	Antenna Factor	Max. EIRP	Max. EIRP	Polarization	
			(dBm)	(dBm)	(dB)	Average	Average	Of Max. ERP	
						(dBm)	(mW)		
5.0MHz Band 16 QAM	1/#Mid	2502.5	-2.01	4.54	27.75	21.20	131.826	Horizontal	Pass
		2535	-1.70	4.69	27.72	21.33	135.831	Horizontal	Pass
		2567.5	-1.78	4.71	27.71	21.22	132.434	Horizontal	Pass
10.0MHz Band 16 QAM	1/#Mid	2505	-1.90	4.55	27.76	21.31	135.207	Horizontal	Pass
		2535	-1.91	4.69	27.72	21.12	129.420	Horizontal	Pass
		2565	-2.18	4.72	27.70	20.80	120.226	Horizontal	Pass
15.0MHz Band 16 QAM	1/#Mid	2507.5	-2.08	4.55	27.77	21.14	130.017	Horizontal	Pass
		2535	-2.05	4.69	27.72	20.98	125.314	Horizontal	Pass
		2562.5	-1.66	4.72	27.69	21.31	135.207	Horizontal	Pass
20.0MHz Band 16 QAM	1/#Mid	2510	-1.96	4.57	27.78	21.25	133.352	Horizontal	Pass
		2535	-1.63	4.73	27.72	21.36	136.773	Horizontal	Pass
		2560	-1.73	4.75	27.68	21.20	131.826	Horizontal	Pass
5.0MHz Band 16 QAM	1/#Mid	2502.5	-3.83	4.54	27.75	19.38	86.696	Vertical	Pass
		2535	-3.51	4.69	27.72	19.52	89.536	Vertical	Pass
		2567.5	-2.91	4.71	27.71	20.09	102.094	Vertical	Pass
10.0MHz Band 16 QAM	1/#Mid	2505	-2.66	4.55	27.76	20.55	113.501	Vertical	Pass
		2535	-3.20	4.69	27.72	19.83	96.161	Vertical	Pass
		2565	-3.04	4.72	27.70	19.94	98.628	Vertical	Pass
15.0MHz Band 16 QAM	1/#Mid	2507.5	-3.52	4.55	27.77	19.70	93.325	Vertical	Pass
		2535	-3.11	4.69	27.72	19.92	98.175	Vertical	Pass
		2562.5	-2.10	4.72	27.69	20.87	122.180	Vertical	Pass
20.0MHz Band 16 QAM	1/#Mid	2510	-2.43	4.57	27.78	20.78	119.674	Vertical	Pass
		2535	-2.09	4.73	27.72	20.90	123.027	Vertical	Pass
		2560	-2.28	4.75	27.68	20.65	116.145	Vertical	Pass

Note:

SG Level= Signal generator output

Max. EIRP Average (dBm)= Factor Gain (dB)+ SG Level (dBm)- Cable Loss(dBm)

Factor Gain(dB)=Antenna Gain(dB) + Amplifier Factor (dB)

8.6 LTE BAND 13

Radiated Power (ERP) for Band 13										
Mode	RB/RB SIZE	Frequency	Result							Conclusion
			SG Level	Cable Loss	Antenna Factor	Correction	Max. EIRP	Max. EIRP	Polarization	
			(dBm)	(dBm)	(dB)	(dB)	Average	Average	Of Max. ERP	
							(dBm)	(mW)		
5.0MHz Band QPSK	25/0	779.5	6.62	1.91	19.23	2.15	21.79	151.01	Horizontal	Pass
		782	6.47	1.91	19.26	2.15	21.67	146.89	Horizontal	Pass
		784.5	4.90	1.92	19.33	2.15	20.16	103.75	Horizontal	Pass
10.0MHz Band QPSK	50/0	782	5.02	1.91	19.25	2.15	20.21	104.95	Horizontal	Pass
			6.77	1.91	19.26	2.15	21.97	157.40	Horizontal	Pass
			5.30	1.92	19.32	2.15	20.55	113.50	Horizontal	Pass
5.0MHz Band QPSK	25/0	779.5	4.94	1.91	19.23	2.15	20.11	102.57	Vertical	Pass
		782	5.73	1.91	19.26	2.15	20.93	123.88	Vertical	Pass
		784.5	4.93	1.92	19.33	2.15	20.19	104.47	Vertical	Pass
10.0MHz Band QPSK	50/0	782	5.08	1.91	19.25	2.15	20.27	106.41	Vertical	Pass
			5.07	1.91	19.26	2.15	20.27	106.41	Vertical	Pass
			5.27	1.92	19.32	2.15	20.52	112.72	Vertical	Pass

Radiated Power (ERP) for Band 13											
Mode	RB/RB SIZE	Frequency	Result							Polarization Of Max. ERP	Conclusion
			SG Level	Cable Loss	Antenna Factor	Correction	Max. EIRP	Max. EIRP			
			(dBm)	(dBm)	(dB)	(dB)	Average	Average			
							(dBm)	(mW)			
5.0MHz Band 16 QAM	25/0	779.5	6.56	1.91	19.23	2.15	21.73	148.94	Horizontal	Pass	
		782	5.36	1.91	19.26	2.15	20.56	113.76	Horizontal	Pass	
		784.5	5.27	1.92	19.33	2.15	20.53	112.98	Horizontal	Pass	
10.0MHz Band 16 QAM	50/0	782	5.64	1.91	19.25	2.15	20.83	121.06	Horizontal	Pass	
			6.55	1.91	19.26	2.15	21.75	149.62	Horizontal	Pass	
			4.97	1.92	19.32	2.15	20.22	105.20	Horizontal	Pass	
5.0MHz Band 16 QAM	25/0	779.5	5.13	1.91	19.23	2.15	20.30	107.15	Vertical	Pass	
		782	5.40	1.91	19.26	2.15	20.60	114.82	Vertical	Pass	
		784.5	5.30	1.92	19.33	2.15	20.56	113.76	Vertical	Pass	
10.0MHz Band 16 QAM	50/0	782	5.28	1.91	19.25	2.15	20.47	111.43	Vertical	Pass	
			5.02	1.91	19.26	2.15	20.22	105.20	Vertical	Pass	
			5.27	1.92	19.32	2.15	20.52	112.72	Vertical	Pass	

Note:

SG Level= Signal generator output

Max. EIRP Average (dBm)= Antenna Gain(dB)+ SG Level (dBm)- Cable Loss(dBm)

Factor Gain(dB)=Antenna Gain(dB) + Amplifier Factor (dB)

8.7 LTE BAND 66

Radiated Power (EIRP) for Band 66									
Mode	RB/RB SIZE	Frequency	Result						Conclusion
			SG Level (dBm)	Cable Loss (dBm)	Antenna Factor (dB)	Max. EIRP Average (dBm)	Max. EIRP Average (mW)	Polarization Of Max. ERP	
1.4MHz Band QPSK	1/#Mid	1710.7	-3.07	3.76	28.24	21.41	138.357	Horizontal	Pass
		1745	-2.93	3.91	28.22	21.38	137.404	Horizontal	Pass
		1779.3	-2.80	3.93	28.2	21.47	140.281	Horizontal	Pass
3.0MHz Band QPSK	1/#Mid	1711.5	-3.13	3.77	28.23	21.33	135.831	Horizontal	Pass
		1745	-3.04	3.91	28.24	21.29	134.586	Horizontal	Pass
		1778.5	-3.06	3.94	28.25	21.25	133.352	Horizontal	Pass
5.0MHz Band QPSK	1/#Mid	1712.5	-3.03	3.77	28.31	21.51	141.579	Horizontal	Pass
		1745	-2.71	3.91	28.22	21.60	144.544	Horizontal	Pass
		1777.5	-2.77	3.94	28.2	21.49	140.929	Horizontal	Pass
10.0MHz Band QPSK	1/#Mid	1715	-2.92	3.79	28.33	21.62	145.211	Horizontal	Pass
		1745	-2.65	3.95	28.22	21.62	145.211	Horizontal	Pass
		1775	-2.66	3.97	28.19	21.56	143.219	Horizontal	Pass
15.0MHz Band QPSK	1/#Mid	1717.5	-2.94	3.79	28.34	21.61	144.877	Horizontal	Pass
		1745	-2.75	3.95	28.22	21.52	141.906	Horizontal	Pass
		1772.5	-2.70	3.97	28.18	21.51	141.579	Horizontal	Pass
20.0MHz Band QPSK	1/#Mid	1720	-2.91	3.81	28.35	21.63	145.546	Horizontal	Pass
		1745	-2.65	3.96	28.22	21.61	144.877	Horizontal	Pass
		1770	-2.67	4	28.16	21.49	140.929	Horizontal	Pass
1.4MHz Band QPSK	1/#Mid	1710.7	-3.95	3.76	28.24	20.53	112.980	Vertical	Pass
		1745	-4.22	3.91	28.22	20.09	102.094	Vertical	Pass
		1779.3	-3.92	3.93	28.2	20.35	108.393	Vertical	Pass
3.0MHz Band QPSK	1/#Mid	1711.5	-3.84	3.77	28.23	20.62	115.345	Vertical	Pass
		1745	-3.85	3.91	28.24	20.48	111.686	Vertical	Pass
		1778.5	-3.91	3.94	28.25	20.40	109.648	Vertical	Pass
5.0MHz Band QPSK	1/#Mid	1712.5	-3.81	3.77	28.31	20.73	118.304	Vertical	Pass
		1745	-3.44	3.91	28.22	20.87	122.180	Vertical	Pass
		1777.5	-3.95	3.94	28.2	20.31	107.399	Vertical	Pass
10.0MHz Band QPSK	1/#Mid	1715	-3.68	3.79	28.34	20.87	122.180	Vertical	Pass
		1745	-3.60	3.95	28.22	20.67	116.681	Vertical	Pass
		1775	-3.83	3.97	28.18	20.38	109.144	Vertical	Pass
15.0MHz	1/#Mid	1717.5	-4.53	3.81	28.35	20.01	100.231	Vertical	Pass

Band		1745	-3.38	3.96	28.22	20.88	122.462	Vertical	Pass
QPSK		1772.5	-3.74	4	28.16	20.42	110.154	Vertical	Pass
20.0MHz		1720	-4.46	3.79	28.34	20.09	102.094	Vertical	Pass
Band	1/#Mid	1745	-4.32	3.95	28.22	19.95	98.855	Vertical	Pass
QPSK		1770	-3.71	3.97	28.18	20.50	112.202	Vertical	Pass

Radiated Power (EIRP) for Band 66									
Mode	RB/RB SIZE	Frequency	Result						Conclusion
			SG Level (dBm)	Cable Loss (dBm)	Antenna Factor (dB)	Max. EIRP Average (dBm)	Max. EIRP Average (mW)	Polarization Of Max. ERP	
1.4MHz Band 16 QAM	1/#Mid	1710.7	-3.94	3.76	28.24	20.54	113.240	Horizontal	Pass
		1745	-3.55	3.91	28.22	20.76	119.124	Horizontal	Pass
		1779.3	-3.73	3.93	28.2	20.54	113.240	Horizontal	Pass
3.0MHz Band 16 QAM	1/#Mid	1711.5	-4.33	3.77	28.23	20.13	103.039	Horizontal	Pass
		1745	-3.58	3.91	28.24	20.75	118.850	Horizontal	Pass
		1778.5	-3.87	3.94	28.25	20.44	110.662	Horizontal	Pass
5.0MHz Band 16 QAM	1/#Mid	1712.5	-3.75	3.77	28.31	20.79	119.950	Horizontal	Pass
		1745	-3.81	3.91	28.22	20.50	112.202	Horizontal	Pass
		1777.5	-3.48	3.94	28.2	20.78	119.674	Horizontal	Pass
10.0MHz Band 16 QAM	1/#Mid	1715	-3.80	3.79	28.33	20.74	118.577	Horizontal	Pass
		1745	-3.46	3.95	28.22	20.81	120.504	Horizontal	Pass
		1775	-3.78	3.97	28.19	20.44	110.662	Horizontal	Pass
15.0MHz Band 16 QAM	1/#Mid	1717.5	-3.79	3.79	28.34	20.76	119.124	Horizontal	Pass
		1745	-3.61	3.95	28.22	20.66	116.413	Horizontal	Pass
		1772.5	-3.40	3.97	28.18	20.81	120.504	Horizontal	Pass
20.0MHz Band 16 QAM	1/#Mid	1720	-3.62	3.81	28.35	20.92	123.595	Horizontal	Pass
		1745	-3.40	3.96	28.22	20.86	121.899	Horizontal	Pass
		1770	-3.34	4	28.16	20.82	120.781	Horizontal	Pass
1.4MHz Band 16 QAM	1/#Mid	1710.7	-4.80	3.76	28.24	19.68	92.897	Vertical	Pass
		1745	-4.79	3.91	28.22	19.52	89.536	Vertical	Pass
		1779.3	-4.61	3.93	28.2	19.66	92.470	Vertical	Pass
3.0MHz Band 16 QAM	1/#Mid	1711.5	-5.17	3.77	28.23	19.29	84.918	Vertical	Pass
		1745	-4.27	3.91	28.24	20.06	101.391	Vertical	Pass
		1778.5	-3.77	3.94	28.25	20.54	113.240	Vertical	Pass
5.0MHz Band 16 QAM	1/#Mid	1712.5	-4.36	3.77	28.31	20.18	104.232	Vertical	Pass
		1745	-4.27	3.91	28.22	20.04	100.925	Vertical	Pass
		1777.5	-4.50	3.94	28.2	19.76	94.624	Vertical	Pass
10.0MHz Band 16 QAM	1/#Mid	1715	-5.48	3.79	28.34	19.07	80.724	Vertical	Pass
		1745	-4.33	3.95	28.22	19.94	98.628	Vertical	Pass
		1775	-3.65	3.97	28.18	20.56	113.763	Vertical	Pass
15.0MHz Band 16	1/#Mid	1717.5	-4.07	3.81	28.35	20.47	111.429	Vertical	Pass
		1745	-5.27	3.96	28.22	18.99	79.250	Vertical	Pass

QAM		1772.5	-4.57	4	28.16	19.59	90.991	Vertical	Pass
20.0MHz	1/#Mid	1720	-4.51	3.79	28.34	20.04	100.925	Vertical	Pass
Band 16		1745	-3.86	3.95	28.22	20.41	109.901	Vertical	Pass
QAM		1770	-4.01	3.97	28.18	20.20	104.713	Vertical	Pass

Note:

SG Level= Signal generator output

Max. EIRP Average (dBm)= Antenna Gain(dB)+ SG Level (dBm)- Cable Loss(dBm)

Factor Gain(dB)=Antenna Gain(dB) + Amplifier Factor (dB)

9. SPURIOUS RADIATION EMISSION

RULE PART(S)

FCC: §2.1051, §22.917(a), §24.238(a), §27.53(c)(g)(h)(m)

LIMIT

For Band 7, the minimum permissible attenuation level of any spurious emission is $55 + \log_{10}(P)$ [Watts].

The minimum permissible attenuation level of any spurious emission is $43 + \log_{10}(P)$ [Watts], where P is the transmitter power in Watts.

TEST PROCEDURE

For Cellular equipment - Compliance with these rules is based on the use of measurement instrumentation employing a resolution bandwidth of 100 kHz or greater. In the 1 MHz bands immediately outside and adjacent to the frequency block a resolution bandwidth of at least one percent of the emission bandwidth of the fundamental emission of the transmitter may be employed. A narrower resolution bandwidth is permitted in all cases to improve measurement accuracy provided the measured power is integrated over the full required measurement bandwidth (i.e. 100 kHz or 1 percent of emission bandwidth, as specified). The emission bandwidth is defined as the width of the signal between two points, one below the carrier center frequency and one above the carrier center frequency, outside of which all emissions are attenuated at least 26 dB below the transmitter power.

For PCS equipment - Compliance with these rules is based on the use of measurement instrumentation employing a resolution bandwidth of 1 MHz or greater. However, in the 1 MHz bands immediately outside and adjacent to the frequency block a resolution bandwidth of at least one percent of the emission bandwidth of the fundamental emission of the transmitter may be employed. A narrower resolution bandwidth is permitted in all cases to improve measurement accuracy provided the measured power is integrated over the full required measurement bandwidth (i.e. 1 MHz or 1 percent of emission bandwidth, as specified). The emission bandwidth is defined as the width of the signal between two points, one below the carrier center frequency and one above the carrier center frequency, outside of which all emissions are attenuated at least 26 dB below the transmitter power.

The unwanted emission power shall be measured with a resolution bandwidth of at least 1% of the occupied bandwidth in the 1 MHz band immediately outside and adjacent to the channel edge of the equipment. Beyond the 1 MHz band immediately outside the channel edge of the equipment, a resolution bandwidth of 1 MHz shall be employed. A narrower resolution bandwidth is allowed to be used provided that the measured power is integrated over the full required measurement bandwidth of 1 MHz or 1% of the occupied bandwidth as applicable.

The power of any unwanted emissions measured from the channel edge of the equipment shall be attenuated below the transmitter power, P (dBW), as follows:

- a. for base station and subscriber equipment, other than mobile subscriber equipment, the attenuation shall not be less than $43 + 10 \text{ Log}_{10}(p)$, dB; and
- b. for mobile subscriber equipment, the attenuation shall not be less than $43 + 10 \text{ Log}_{10}(p)$, dB at the channel edges and $55 + 10 \text{ Log}_{10}(p)$ at 5.5 MHz away and beyond the channel edges where p in (a) and (b) is the transmitter power measured in watts.

MODES TESTED

- LTE Band 2
- LTE Band 4
- LTE Band 5
- LTE Band 7
- LTE Band 13
- LTE Band 66

RESULTS

PASS

9.1 LTE BAND 2

QPSK EIRP POWER FOR LTE BAND 2 (1.4MHZ BANDWIDTH)

Test Results for Low Channel 1850.7MHz							
Frequency(MHz)	SG Level(dBm)	Cable Loss(dB)	Antenna Factor(dB)	Absolute Level(dBm)	Limit (dBm)	Margin(dBm)	Polarity
3701.4	-52.07	4.04	33.51	-22.60	-13	-9.60	Horizontal
3701.4	-53.87	4.04	33.51	-24.40	-13	-11.40	Vertical
5552.1	-50.08	5.24	35.84	-19.48	-13	-6.48	Vertical
5552.1	-53.22	5.24	35.84	-22.62	-13	-9.62	Horizontal
175.4	-37.63	1.43	16.02	-23.04	-13	-10.04	Vertical
429.1	-42.10	1.30	17.99	-25.41	-13	-12.41	Horizontal
Test Results for Mid Channel 1880MHz							
3760.0	-50.02	4.04	33.56	-20.50	-13	-7.50	Horizontal
3760.0	-52.46	4.04	33.56	-22.94	-13	-9.94	Vertical
5640.0	-49.55	5.24	35.91	-18.88	-13	-5.88	Vertical
5640.0	-52.76	5.24	35.91	-22.09	-13	-9.09	Horizontal
185.7	-36.16	1.62	16.97	-20.81	-13	-7.81	Vertical
460.9	-39.37	1.74	15.98	-25.14	-13	-12.14	Horizontal
Test Results for High Channel 1909.3MHz							
3818.6	-50.98	4.04	34.00	-21.02	-13	-8.02	Horizontal
3818.6	-50.30	4.04	34.00	-20.34	-13	-7.34	Vertical
5727.9	-51.20	5.24	36.04	-20.40	-13	-7.40	Vertical
5727.9	-49.29	5.24	36.04	-18.49	-13	-5.49	Horizontal
203.4	-44.35	1.42	17.29	-28.48	-13	-15.48	Vertical
239.5	-34.80	1.50	17.90	-18.39	-13	-5.39	Horizontal

QPSK EIRP POWER FOR LTE BAND 2 (20.0MHZ BANDWIDTH)

Test Results for Low Channel 1860MHz							
Frequency(MHz)	SG Level(dBm)	Cable Loss(dB)	Antenna Factor(dB)	Absolute Level(dBm)	Limit (dBm)	Margin(dBm)	Polarity
3720.0	-49.33	4.07	33.54	-19.86	-13	-6.86	Horizontal
3720.0	-52.02	4.07	33.54	-22.55	-13	-9.55	Vertical
5580.0	-49.61	5.28	35.86	-19.03	-13	-6.03	Vertical
5580.0	-49.61	5.28	35.86	-19.03	-13	-6.03	Horizontal
185.5	-39.63	1.58	16.89	-24.31	-13	-11.31	Vertical
269.7	-41.38	1.76	17.26	-25.88	-13	-12.88	Horizontal
Test Results for Mid Channel 1880MHz							
3760.0	-48.65	4.04	33.56	-19.13	-13	-6.13	Horizontal
3760.0	-47.01	4.04	33.56	-17.49	-13	-4.49	Vertical
5640.0	-51.46	5.24	35.91	-20.79	-13	-7.79	Vertical
5640.0	-51.04	5.24	35.91	-20.37	-13	-7.37	Horizontal
185.3	-43.06	1.46	16.27	-28.25	-13	-15.25	Vertical
243.4	-40.98	1.59	15.15	-27.42	-13	-14.42	Horizontal
Test Results for High Channel 1900MHz							
3800.0	-48.79	4.04	34.00	-18.83	-13	-5.83	Horizontal
3800.0	-47.60	4.04	34.00	-17.64	-13	-4.64	Vertical
5700.0	-53.30	5.24	36.04	-22.50	-13	-9.50	Vertical
5700.0	-50.95	5.24	36.04	-20.15	-13	-7.15	Horizontal
180.4	-44.23	1.36	17.39	-28.19	-13	-15.19	Vertical
315.0	-43.11	1.66	15.39	-29.38	-13	-16.38	Horizontal

9.2 LTE BAND 4

QPSK EIRP POWER FOR LTE BAND 4 (1.4MHZ BANDWIDTH)

Test Results for Low Channel 1710.7MHz							
Frequency(MHz)	SG Level(dBm)	Cable Loss(dB)	Antenna Factor(dB)	Absolute Level(dBm)	Limit (dBm)	Margin(dBm)	Polarity
3421.4	-49.94	4.02	29.80	-24.16	-13	-11.16	Horizontal
3421.4	-49.07	4.02	29.80	-23.29	-13	-10.29	Vertical
5132.1	-51.02	5.24	35.84	-20.42	-13	-7.42	Vertical
5132.1	-52.19	5.24	35.84	-21.59	-13	-8.59	Horizontal
195.2	-36.98	1.68	16.04	-22.62	-13	-9.62	Vertical
366.0	-41.57	1.78	17.74	-25.61	-13	-12.61	Horizontal
Test Results for Mid Channel 1732.5MHz							
3465.0	-46.54	4.03	30.00	-20.57	-13	-7.57	Horizontal
3465.0	-44.08	4.03	30.00	-18.11	-13	-5.11	Vertical
5197.5	-51.87	5.25	35.86	-21.26	-13	-8.26	Vertical
5197.5	-49.42	5.25	35.86	-18.81	-13	-5.81	Horizontal
209.7	-34.74	1.72	17.69	-18.77	-13	-5.77	Vertical
267.7	-36.10	1.62	16.02	-21.69	-13	-8.69	Horizontal
Test Results for High Channel 1754.3MHz							
3508.6	-53.69	4.05	30.01	-27.73	-13	-14.73	Horizontal
3508.6	-49.00	4.05	30.01	-23.04	-13	-10.04	Vertical
5262.9	-50.33	5.26	35.86	-19.73	-13	-6.73	Vertical
5262.9	-51.56	5.26	35.86	-20.96	-13	-7.96	Horizontal
186.5	-40.58	1.80	16.69	-25.69	-13	-12.69	Vertical
297.0	-40.30	1.75	16.66	-25.40	-13	-12.40	Horizontal

QPSK EIRP POWER FOR LTE BAND 4 (20.0MHZ BANDWIDTH)

Test Results for Low Channel 1720MHz							
Frequency(MHz)	SG Level(dBm)	Cable Loss(dB)	Antenna Factor(dB)	Absolute Level(dBm)	Limit (dBm)	Margin(dBm)	Polarity
3440.0	-50.03	4.02	29.80	-24.25	-13	-11.25	Horizontal
3440.0	-46.63	4.02	29.80	-20.85	-13	-7.85	Vertical
5160.0	-52.69	5.24	35.84	-22.09	-13	-9.09	Vertical
5160.0	-49.34	5.24	35.84	-18.74	-13	-5.74	Horizontal
203.4	-35.10	1.57	17.26	-19.41	-13	-6.41	Vertical
368.0	-36.74	1.78	16.35	-22.17	-13	-9.17	Horizontal
Test Results for Mid Channel 1732.5MHz							
3465.0	-51.23	4.03	30.00	-25.26	-13	-12.26	Horizontal
3465.0	-51.58	4.03	30.00	-25.61	-13	-12.61	Vertical
5197.5	-53.30	5.25	35.86	-22.69	-13	-9.69	Vertical
5197.5	-50.44	5.25	35.86	-19.83	-13	-6.83	Horizontal
191.9	-36.39	1.44	17.95	-19.88	-13	-6.88	Vertical
279.1	-42.67	1.65	16.09	-28.23	-13	-15.23	Horizontal
Test Results for High Channel 1745MHz							
3490.0	-44.88	2.91	27.68	-20.11	-13	-7.11	Horizontal
3490.0	-53.33	2.91	27.68	-28.56	-13	-15.56	Vertical
5235.0	-48.29	5.26	35.86	-17.69	-13	-4.69	Vertical
5235.0	-53.07	5.26	35.86	-22.47	-13	-9.47	Horizontal
190.8	-38.50	1.61	16.85	-23.26	-13	-10.26	Vertical
344.3	-41.33	1.61	15.19	-27.75	-13	-14.75	Horizontal

9.3 LTE BAND 5

QPSK EIRP POWER FOR LTE BAND 5 (1.4MHZ BANDWIDTH)

Test Results for Low Channel 824.7MHz							
Frequency(MHz)	SG Level(dBm)	Cable Loss(dB)	Antenna Factor(dB)	Absolute Level(dBm)	Limit (dBm)	Margin(dBm)	Polarity
1649.4	-46.14	2.78	27.50	-21.42	-13	-8.42	Horizontal
1649.4	-50.80	2.78	27.50	-26.08	-13	-13.08	Vertical
2474.1	-44.68	2.90	27.80	-19.78	-13	-6.78	Vertical
2474.1	-52.34	2.90	27.80	-27.44	-13	-14.44	Horizontal
177.9	-43.96	1.76	17.59	-28.13	-13	-15.13	Vertical
294.8	-41.90	1.63	15.87	-27.66	-13	-14.66	Horizontal
Test Results For Mid Channel 836.5MHz							
1673.0	-44.60	2.80	27.48	-19.92	-13	-6.92	Horizontal
1673.0	-50.84	2.80	27.48	-26.16	-13	-13.16	Vertical
2509.5	-52.70	2.91	27.70	-27.91	-13	-14.91	Vertical
2509.5	-53.13	2.91	27.70	-28.34	-13	-15.34	Horizontal
198.1	-39.12	1.61	15.68	-25.05	-13	-12.05	Vertical
337.5	-39.57	1.59	17.52	-23.65	-13	-10.65	Horizontal
Test Results for High Channel 848.3MHz							
1696.6	-49.51	2.82	27.43	-24.90	-13	-11.90	Horizontal
1696.6	-46.28	2.82	27.43	-21.67	-13	-8.67	Vertical
2544.9	-48.92	2.92	27.74	-24.10	-13	-11.10	Vertical
2544.9	-51.54	2.92	27.74	-26.72	-13	-13.72	Horizontal
180.7	-37.18	1.69	16.67	-22.19	-13	-9.19	Vertical
289.3	-35.40	1.70	17.18	-19.92	-13	-6.92	Horizontal

QPSK EIRP POWER FOR LTE BAND 5 (10MHZ BANDWIDTH)

Test Results for Low Channel 829MHz							
Frequency(MHz)	SG Level(dBm)	Cable Loss(dB)	Antenna Factor(dB)	Absolute Level(dBm)	Limit (dBm)	Margin(dBm)	Polarity
1658.0	-50.26	2.78	27.50	-25.54	-13	-12.54	Horizontal
1658.0	-49.67	2.78	27.50	-24.95	-13	-11.95	Vertical
2487.0	-47.29	2.90	27.80	-22.39	-13	-9.39	Vertical
2487.0	-53.91	2.90	27.80	-29.01	-13	-16.01	Horizontal
210.1	-36.66	1.71	15.57	-22.80	-13	-9.80	Vertical
395.2	-40.60	1.34	16.40	-25.54	-13	-12.54	Horizontal
Test Results for Mid Channel 836.5MHz							
1673.0	-49.23	2.80	27.48	-24.55	-13	-11.55	Horizontal
1673.0	-52.09	2.80	27.48	-27.41	-13	-14.41	Vertical
2509.5	-46.52	2.91	27.70	-21.73	-13	-8.73	Vertical
2509.5	-52.11	2.91	27.70	-27.32	-13	-14.32	Horizontal
184.5	-43.45	1.44	17.04	-27.85	-13	-14.85	Vertical
382.9	-38.21	1.76	17.62	-22.35	-13	-9.35	Horizontal
Test Results for High Channel 844MHz							
1688.0	-45.58	2.82	27.43	-20.97	-13	-7.97	Horizontal
1688.0	-52.56	2.82	27.43	-27.95	-13	-14.95	Vertical
2532.0	-48.90	2.92	27.74	-24.08	-13	-11.08	Vertical
2532.0	-52.01	2.92	27.74	-27.19	-13	-14.19	Horizontal
182.7	-35.67	1.74	17.70	-19.71	-13	-6.71	Vertical
374.4	-44.98	1.41	17.46	-28.92	-13	-15.92	Horizontal

9.4 LTE BAND 7

QPSK EIRP POWER FOR LTE BAND 7 (5.0MHZ BANDWIDTH)

Test Results for Low Channel 2502.5MHz							
Frequency(MHz)	SG Level(dBm)	Cable Loss(dB)	Antenna Factor(dB)	Absolute Level(dBm)	Limit (dBm)	Margin(dBm)	Polarity
5005.0	-62.02	5.23	35.81	-31.44	-25	-6.44	Horizontal
5005.0	-60.77	5.23	35.81	-30.19	-25	-5.19	Vertical
7507.5	-62.56	5.67	36.85	-31.38	-25	-6.38	Vertical
7507.5	-68.30	5.67	36.85	-37.12	-25	-12.12	Horizontal
201.3	-49.02	1.73	17.97	-32.78	-25	-7.78	Vertical
331.5	-45.50	1.38	15.11	-31.77	-25	-6.77	Horizontal
Test Results for Mid Channel 2535MHz							
5070.0	-63.30	5.23	35.82	-32.71	-25	-7.71	Horizontal
5070.0	-65.00	5.23	35.82	-34.41	-25	-9.41	Vertical
7605.0	-62.50	5.67	36.85	-31.32	-25	-6.32	Vertical
7605.0	-62.16	5.67	36.85	-30.98	-25	-5.98	Horizontal
193.6	-51.95	1.77	16.17	-37.54	-25	-12.54	Vertical
275.7	-48.08	1.63	15.21	-34.50	-25	-9.50	Horizontal
Test Results for High Channel 2567.5MHz							
5135.0	-64.05	5.24	35.83	-33.46	-25	-8.46	Horizontal
5135.0	-61.39	5.24	35.83	-30.80	-25	-5.80	Vertical
7702.5	-64.05	5.68	36.87	-32.86	-25	-7.86	Vertical
7702.5	-63.18	5.68	36.87	-31.99	-25	-6.99	Horizontal
192.8	-52.20	1.58	17.56	-36.22	-25	-11.22	Vertical
391.6	-47.24	1.45	16.58	-32.11	-25	-7.11	Horizontal

QPSK EIRP POWER FOR LTE BAND 7 (20.0MHZ BANDWIDTH)

Test Results for Low Channel 2510MHz							
Frequency(MHz)	SG Level(dBm)	Cable Loss(dB)	Antenna Factor(dB)	Absolute Level(dBm)	Limit (dBm)	Margin(dBm)	Polarity
5020.0	-63.26	5.23	35.82	-32.67	-25	-7.67	Horizontal
5020.0	-63.30	5.23	35.82	-32.71	-25	-7.71	Vertical
7530.0	-61.91	5.67	36.86	-30.72	-25	-5.72	Vertical
7530.0	-63.30	5.67	36.86	-32.11	-25	-7.11	Horizontal
193.8	-50.79	1.63	15.76	-36.66	-25	-11.66	Vertical
326.3	-49.56	1.71	15.44	-35.83	-25	-10.83	Horizontal
Test Results for Mid Channel 2535MHz							
5070.0	-63.50	5.23	35.82	-32.91	-25	-7.91	Horizontal
5070.0	-61.62	5.23	35.82	-31.03	-25	-6.03	Vertical
7605.0	-62.96	5.67	36.85	-31.78	-25	-6.78	Vertical
7605.0	-63.29	5.67	36.85	-32.11	-25	-7.11	Horizontal
177.0	-51.30	1.79	16.84	-36.24	-25	-11.24	Vertical
364.6	-48.61	1.71	17.64	-32.68	-25	-7.68	Horizontal
Test Results for High Channel 2560MHz							
5120.0	-64.71	5.24	35.83	-34.12	-25	-9.12	Horizontal
5120.0	-64.96	5.24	35.83	-34.37	-25	-9.37	Vertical
7680.0	-63.33	5.70	36.88	-32.15	-25	-7.15	Vertical
7680.0	-64.10	5.70	36.88	-32.92	-25	-7.92	Horizontal
189.4	-44.50	1.79	16.84	-29.44	-25	-4.44	Vertical
290.1	-47.13	1.71	17.64	-31.20	-25	-6.20	Horizontal

9.5 LTE BAND 13
QPSK EIRP POWER FOR LTE BAND 13 (5MHz BANDWIDTH)

Test Results for Low Channel 779.5MHz							
Frequency(MHz)	SG Level(dBm)	Cable Loss(dB)	Antenna Factor(dB)	Absolute Level(dBm)	Limit (dBm)	Margin(dBm)	Polarity
1559.0	-69.98	2.61	27.28	-45.31	-40	-5.31	Horizontal
1559.0	-72.70	2.61	27.28	-48.03	-40	-8.03	Vertical
2338.5	-43.63	2.87	27.59	-18.91	-13	-5.91	Vertical
2338.5	-44.82	2.87	27.59	-20.10	-13	-7.10	Horizontal
120.1	-37.29	1.54	15.61	-23.22	-13	-10.22	Vertical
197.8	-35.86	1.51	15.21	-22.16	-13	-9.16	Horizontal
Test Results For Mid Channel 782MHz							
1564.0	-73.95	2.62	27.30	-49.27	-40	-9.27	Horizontal
1564.0	-69.49	2.62	27.30	-44.81	-40	-4.81	Vertical
2346.0	-42.76	2.87	27.62	-18.01	-13	-5.01	Vertical
2346.0	-42.22	2.87	27.62	-17.47	-13	-4.47	Horizontal
131.2	-39.08	1.65	16.17	-24.56	-13	-11.56	Vertical
267.5	-34.75	1.48	16.88	-19.35	-13	-6.35	Horizontal
Test Results for High Channel 784.5MHz							
1569.0	-70.96	2.66	27.28	-46.34	-40	-6.34	Horizontal
1569.0	-71.48	2.66	27.28	-46.86	-40	-6.86	Vertical
2353.5	-44.05	2.88	27.60	-19.33	-13	-6.33	Vertical
2353.5	-42.37	2.88	27.60	-17.65	-13	-4.65	Horizontal
80.8	-37.05	1.54	16.40	-22.19	-13	-9.19	Vertical
155.6	-39.03	1.43	15.77	-24.69	-13	-11.69	Horizontal

QPSK EIRP POWER FOR LTE BAND 13 (10MHZ BANDWIDTH)

Test Results for Channel 782MHz							
Frequency(MHz)	SG Level(dBm)	Cable Loss(dB)	Antenna Factor(dB)	Absolute Level(dBm)	Limit (dBm)	Margin(dBm)	Polarity
1564.0	-69.75	2.62	27.30	-45.07	-40	-5.07	Horizontal
1564.0	-73.85	2.62	27.30	-49.17	-40	-9.17	Vertical
2346.0	-41.96	2.87	27.62	-17.21	-13	-4.21	Vertical
2346.0	-46.30	2.87	27.62	-21.55	-13	-8.55	Horizontal
129.1	-37.13	1.43	17.03	-21.53	-13	-8.53	Vertical
86.9	-35.20	1.62	16.63	-20.19	-13	-7.19	Horizontal

Note: $P_{Mea}(dBm) = Power(dBm) + ARpl(dBm)$

. Over Limit = : $P_{Mea}(dBm) - Limit(dBm)$

. Both QPSK and 16QAM has been tested, the worst case is QPSK mode, the report just reported the worst case.

9.6 LTE BAND 66

QPSK EIRP POWER FOR LTE BAND 66 (1.4MHZ BANDWIDTH)

Test Results for Low Channel 1710.7MHz							
Frequency(MHz)	SG Level(dBm)	Cable Loss(dB)	Antenna Factor(dB)	Absolute Level(dBm)	Limit (dBm)	Margin(dBm)	Polarity
3421.4	-44.91	4.02	29.80	-19.13	-13	-6.13	Horizontal
3421.4	-50.09	4.02	29.80	-24.31	-13	-11.31	Vertical
5132.1	-53.01	5.24	35.84	-22.41	-13	-9.41	Vertical
5132.1	-53.55	5.24	35.84	-22.95	-13	-9.95	Horizontal
112.6	-48.17	1.52	15.57	-34.12	-13	-21.12	Vertical
220.5	-52.17	1.33	17.14	-36.36	-13	-23.36	Horizontal
Test Results for Mid Channel 1745MHz							
3490.0	-50.93	4.03	30.00	-24.96	-13	-11.96	Horizontal
3490.0	-51.41	4.03	30.00	-25.44	-13	-12.44	Vertical
5235.0	-49.92	5.25	35.86	-19.31	-13	-6.31	Vertical
5235.0	-48.12	5.25	35.86	-17.51	-13	-4.51	Horizontal
157.3	-46.57	1.53	17.13	-30.97	-13	-17.97	Vertical
213.1	-47.25	1.41	15.95	-32.71	-13	-19.71	Horizontal
Test Results for High Channel 1779.3MHz							
3558.6	-51.33	4.05	30.01	-25.37	-13	-12.37	Horizontal
3558.6	-54.05	4.05	30.01	-28.09	-13	-15.09	Vertical
5337.9	-52.73	5.26	35.86	-22.13	-13	-9.13	Vertical
5337.9	-53.21	5.26	35.86	-22.61	-13	-9.61	Horizontal
170.6	-54.28	1.44	15.51	-40.21	-13	-27.21	Vertical
169.0	-45.33	1.78	15.76	-31.35	-13	-18.35	Horizontal

QPSK EIRP POWER FOR LTE BAND 66 (20MHZ BANDWIDTH)

Test Results for Low Channel 1720MHz							
Frequency(MHz)	SG Level(dBm)	Cable Loss(dB)	Antenna Factor(dB)	Absolute Level(dBm)	Limit (dBm)	Margin(dBm)	Polarity
3440.0	-44.77	4.02	29.80	-18.99	-13	-5.99	Horizontal
3440.0	-51.36	4.02	29.80	-25.58	-13	-12.58	Vertical
5160.0	-53.52	5.24	35.84	-22.92	-13	-9.92	Vertical
5160.0	-54.84	5.24	35.84	-24.24	-13	-11.24	Horizontal
268.8	-48.52	1.62	17.02	-33.12	-13	-20.12	Vertical
161.4	-44.43	1.32	17.31	-28.44	-13	-15.44	Horizontal
Test Results for Mid Channel 1745MHz							
3490.0	-48.25	4.03	30.00	-22.28	-13	-9.28	Horizontal
3490.0	-48.17	4.03	30.00	-22.20	-13	-9.20	Vertical
5235.0	-54.74	5.25	35.86	-24.13	-13	-11.13	Vertical
5235.0	-51.26	5.25	35.86	-20.65	-13	-7.65	Horizontal
159.9	-50.04	1.45	15.17	-36.32	-13	-23.32	Vertical
172.1	-50.99	1.48	17.82	-34.65	-13	-21.65	Horizontal
Test Results for High Channel 1770MHz							
3540.0	-48.01	2.91	27.68	-23.24	-13	-10.24	Horizontal
3540.0	-46.29	2.91	27.68	-21.52	-13	-8.52	Vertical
5310.0	-53.28	5.26	35.86	-22.68	-13	-9.68	Vertical
5310.0	-51.30	5.26	35.86	-20.70	-13	-7.70	Horizontal
197.3	-45.36	1.76	16.38	-30.74	-13	-17.74	Vertical
158.5	-52.54	1.43	17.13	-36.84	-13	-23.84	Horizontal

Note: $P_{Mea}(dBm) = Power(dBm) + AR_{pl}(dBm)$

Over Limit = $P_{Mea}(dBm) - Limit(dBm)$

We test both H direction and V direction, recorded worst case direction.

Both QPSK and 16QAM has been tested, the worst case is QPSK mode, the report just reported the worst case.

10. FREQUENCY STABILITY

RULE PART(S)

FCC: §2.1055, §22.355, §24.235, §27.54,

LIMITS

§22.355 - The carrier frequency shall not depart from the reference frequency in excess of ± 2.5 ppm for mobile stations.

§24.235 - The frequency stability shall be sufficient to ensure that the fundamental emission stays within the authorized frequency block.

TEST PROCEDURE

Use CMW 500 with Frequency Error measurement capability.

- Temp. = -30° to $+50^{\circ}\text{C}$
- Voltage = low voltage DC 3.4V, Normal, DC 3.8V and High voltage, DC 4.4V.

Frequency Stability vs Temperature:

The EUT is placed inside a temperature chamber. The temperature is set to -30°C and allowed to stabilize. After sufficient soak time, the transmitting frequency error is measured. The temperature is increased by 10 degrees, allowed to stabilize and soak, and then the measurement is repeated. This is repeated until $+50^{\circ}\text{C}$ is reached.

Frequency Stability vs Voltage:

The peak frequency error is recorded (worst-case).

MODES TESTED

- LTE Band 2
- LTE Band 4
- LTE Band 5
- LTE Band 7
- LTE Band 13
- LTE Band 66

RESULTS

See the following pages.

10.1 LTE BAND 2

QPSK, (20MHz BANDWIDTH)

Frequency error vs. Voltage

Voltage [Vdc]	Frequency [MHz]	Frequency* Error[Hz]	Frequency Error[ppm]	Limit [ppm]
BAND 2 QPSK, (CH 18900 RB size 100 RB Offset 0 20MHz BANDWIDTH)				
3.4	1880	12.3	0.006554	2.5
3.8	1880	13.9	0.007416	2.5
4.4	1880	13.7	0.007281	2.5

Frequency error vs. Temperature

Temperature [°C]	Frequency [MHz]	Frequency* Error[Hz]	Frequency Error[ppm]	Limit [ppm]
BAND 2 QPSK, (CH 18900 RB size 100 RB Offset 0 20MHz BANDWIDTH)				
Normal (25C)	1880	13.0	0.006939	2.5
Extreme (50C)	1880	11.3	0.005986	2.5
Extreme (40C)	1880	13.2	0.007041	2.5
Extreme (30C)	1880	13.2	0.007034	2.5
Extreme (10C)	1880	14.3	0.007617	2.5
Extreme (0C)	1880	12.3	0.006516	2.5
Extreme (-10C)	1880	12.9	0.006861	2.5
Extreme (-20C)	1880	13.6	0.007243	2.5
Extreme (-30C)	1880	15.1	0.008036	2.5

16QAM, (20MHz BANDWIDTH)

Frequency error vs. Voltage

Voltage [Vdc]	Frequency [MHz]	Frequency* Error[Hz]	Frequency Error[ppm]	Limit [ppm]
BAND 2 16QAM, (CH 18900 RB size 100 RB Offset 0 20MHz BANDWIDTH)				
3.4	1880	9.8	0.005213	2.5
3.8	1880	8.7	0.004606	2.5
4.4	1880	8.0	0.004265	2.5

Frequency error vs. Temperature

Temperature [°C]	Frequency [MHz]	Frequency* Error[Hz]	Frequency Error[ppm]	Limit [ppm]
BAND 2 16QAM, (CH 18900 RB size 100 RB Offset 0 20MHz BANDWIDTH)				
Normal (25C)	1880	9.1	0.004842	2.5
Extreme (50C)	1880	8.5	0.004512	2.5
Extreme (40C)	1880	7.9	0.004191	2.5
Extreme (30C)	1880	9.0	0.004808	2.5
Extreme (10C)	1880	9.2	0.004912	2.5
Extreme (0C)	1880	7.8	0.004127	2.5
Extreme (-10C)	1880	9.3	0.004959	2.5
Extreme (-20C)	1880	8.5	0.004508	2.5
Extreme (-30C)	1880	8.3	0.004425	2.5

***Note:** Frequency error measurements were made by using the build-in capability of the Wireless Communication Test Set.

10.2 LTE BAND 4

QPSK, (10MHz BANDWIDTH)

Frequency error vs. Voltage

Voltage [Vdc]	Frequency [MHz]	Frequency* Error[Hz]	Frequency Error[ppm]	Limit [ppm]
BAND 4 QPSK, (CH 20175 RB size 100 RB Offset 0 20MHz BANDWIDTH)				
3.4	1732.5	9.3	0.005353	2.5
3.8	1732.5	8.5	0.004887	2.5
4.4	1732.5	8.1	0.004659	2.5

Frequency error vs. Temperature

Temperature [°C]	Frequency [MHz]	Frequency* Error[Hz]	Frequency Error[ppm]	Limit [ppm]
BAND 4 QPSK, (CH 20175 RB size 100 RB Offset 0 20MHz BANDWIDTH)				
Normal (25C)	1732.5	8.3	0.004813	2.5
Extreme (50C)	1732.5	8.8	0.005079	2.5
Extreme (40C)	1732.5	7.4	0.004262	2.5
Extreme (30C)	1732.5	5.9	0.003409	2.5
Extreme (10C)	1732.5	7.3	0.004221	2.5
Extreme (0C)	1732.5	9.1	0.005273	2.5
Extreme (-10C)	1732.5	8.7	0.005000	2.5
Extreme (-20C)	1732.5	6.5	0.003760	2.5
Extreme (-30C)	1732.5	8.1	0.004651	2.5

16QAM, (20MHz BANDWIDTH)

Frequency error vs. Voltage

Voltage [Vdc]	Frequency [MHz]	Frequency* Error[Hz]	Frequency Error[ppm]	Limit [ppm]
BAND 4 16QAM, (CH 20175 RB size 100 RB Offset 0 20MHz BANDWIDTH)				
3.4	1732.5	10.2	0.005915	2.5
3.8	1732.5	8.9	0.005117	2.5
4.4	1732.5	7.9	0.004577	2.5

Frequency error vs. Temperature

Temperature [°C]	Frequency [MHz]	Frequency* Error[Hz]	Frequency Error[ppm]	Limit [ppm]
BAND 4 16QAM, (CH 20175 RB size 100 RB Offset 0 20MHz BANDWIDTH)				
Normal (25C)	1732.5	9.4	0.005429	2.5
Extreme (50C)	1732.5	9.4	0.005423	2.5
Extreme (40C)	1732.5	7.7	0.004468	2.5
Extreme (30C)	1732.5	9.3	0.005358	2.5
Extreme (10C)	1732.5	8.6	0.004987	2.5
Extreme (0C)	1732.5	8.0	0.004606	2.5
Extreme (-10C)	1732.5	8.9	0.005132	2.5
Extreme (-20C)	1732.5	9.3	0.005358	2.5
Extreme (-30C)	1732.5	7.8	0.004479	2.5

***Note:** Frequency error measurements were made by using the build-in capability of the Wireless Communication Test Set.

10.3 LTE BAND 5

QPSK, (10MHz BANDWIDTH)

Frequency error vs. Voltage

Voltage [Vdc]	Frequency [MHz]	Frequency* Error[Hz]	Frequency Error[ppm]	Limit [ppm]
BAND 5 QPSK, (CH 20525 RB size 50 RB Offset 0 10MHz BANDWIDTH)				
3.4	836.5	5.8	0.006961	2.5
3.8	836.5	6.5	0.007760	2.5
4.4	836.5	4.8	0.005788	2.5

Frequency error vs. Temperature

Temperature [°C]	Frequency [MHz]	Frequency* Error[Hz]	Frequency Error[ppm]	Limit [ppm]
BAND 5 QPSK, (CH 20525 RB size 50 RB Offset 0 10MHz BANDWIDTH)				
Normal (25C)	836.5	6.0	0.007118	2.5
Extreme (50C)	836.5	5.5	0.006600	2.5
Extreme (40C)	836.5	6.2	0.007369	2.5
Extreme (30C)	836.5	6.1	0.007254	2.5
Extreme (10C)	836.5	5.8	0.006974	2.5
Extreme (0C)	836.5	4.8	0.005741	2.5
Extreme (-10C)	836.5	5.4	0.006512	2.5
Extreme (-20C)	836.5	5.8	0.006928	2.5
Extreme (-30C)	836.5	6.3	0.007486	2.5

16QAM, (10MHz BANDWIDTH)

Frequency error vs. Voltage

Voltage [Vdc]	Frequency [MHz]	Frequency* Error[Hz]	Frequency Error[ppm]	Limit [ppm]
BAND 5 16QAM, (CH 20525 RB size 50 RB Offset 0 10MHz BANDWIDTH)				
3.4	836.5	5.3	0.006371	2.5
3.8	836.5	6.8	0.008100	2.5
4.4	836.5	5.0	0.005984	2.5

Frequency error vs. Temperature

Temperature [°C]	Frequency [MHz]	Frequency* Error[Hz]	Frequency Error[ppm]	Limit [ppm]
BAND 5 16QAM, (CH 20525 RB size 50 RB Offset 0 10MHz BANDWIDTH)				
Normal (25C)	836.5	5.9	0.007032	2.5
Extreme (50C)	836.5	5.7	0.006834	2.5
Extreme (40C)	836.5	6.4	0.007693	2.5
Extreme (30C)	836.5	6.2	0.007459	2.5
Extreme (10C)	836.5	5.8	0.006982	2.5
Extreme (0C)	836.5	5.3	0.006386	2.5
Extreme (-10C)	836.5	5.4	0.006436	2.5
Extreme (-20C)	836.5	6.1	0.007293	2.5
Extreme (-30C)	836.5	6.4	0.007676	2.5

***Note:** Frequency error measurements were made by using the build-in capability of the Wireless Communication Test Set.

10.4 LTE BAND 7

QPSK, (20MHz BANDWIDTH)

Frequency error vs. Voltage

Voltage [Vdc]	Frequency [MHz]	Frequency* Error[Hz]	Frequency Error[ppm]	Limit [ppm]
BAND 7 QPSK, (CH 21100 RB size 100 RB Offset 0 20MHz BANDWIDTH)				
3.4	2535	9.7	0.003829	2.5
3.8	2535	9.3	0.003671	2.5
4.4	2535	8.1	0.003214	2.5

Frequency error vs. Temperature

Temperature [°C]	Frequency [MHz]	Frequency* Error[Hz]	Frequency Error[ppm]	Limit [ppm]
BAND 7 QPSK, (CH 21100 RB size 100 RB Offset 0 20MHz BANDWIDTH)				
Normal (25C)	2535	8.9	0.003513	2.5
Extreme (50C)	2535	8.6	0.003396	2.5
Extreme (40C)	2535	8.8	0.003469	2.5
Extreme (30C)	2535	9.1	0.003609	2.5
Extreme (10C)	2535	8.1	0.003181	2.5
Extreme (0C)	2535	8.0	0.003164	2.5
Extreme (-10C)	2535	9.3	0.003676	2.5
Extreme (-20C)	2535	8.4	0.003326	2.5
Extreme (-30C)	2535	8.7	0.003443	2.5

16QAM, (20MHz BANDWIDTH)

Frequency error vs. Voltage

Voltage [Vdc]	Frequency [MHz]	Frequency* Error[Hz]	Frequency Error[ppm]	Limit [ppm]
BAND 7 16QAM, (CH 21100 RB size 100 RB Offset 0 20MHz BANDWIDTH)				
3.4	2535	6.9	0.002722	2.5
3.8	2535	6.4	0.002513	2.5
4.4	2535	5.3	0.002098	2.5

Frequency error vs. Temperature

Temperature [°C]	Frequency [MHz]	Frequency* Error[Hz]	Frequency Error[ppm]	Limit [ppm]
BAND 7 16QAM, (CH 21100 RB size 100 RB Offset 0 20MHz BANDWIDTH)				
Normal (25C)	2535	6.9	0.002722	2.5
Extreme (50C)	2535	5.2	0.002051	2.5
Extreme (40C)	2535	5.9	0.002310	2.5
Extreme (30C)	2535	6.5	0.002561	2.5
Extreme (10C)	2535	5.5	0.002167	2.5
Extreme (0C)	2535	5.0	0.001992	2.5
Extreme (-10C)	2535	5.1	0.002011	2.5
Extreme (-20C)	2535	6.0	0.002371	2.5
Extreme (-30C)	2535	5.9	0.002314	2.5

***Note:** Frequency error measurements were made by using the build-in capability of the Wireless Communication Test Set.

10.5 LTE BAND 13

Band 13 QPSK, (10MHz BANDWIDTH RB size 50 RB Offset 0)

Frequency error vs. Voltage

Voltage [Vdc]	Frequency [MHz]	Frequency* Error[Hz]	Frequency Error[ppm]	Limit [ppm]
3.4	782.0	13.0	0.018318	2.5
3.8	782.0	13.5	0.019033	2.5
4.4	782.0	13.7	0.019271	2.5

Frequency error vs. Temperature

Temperature [°C]	Frequency [MHz]	Frequency* Error[Hz]	Frequency Error[ppm]	Limit [ppm]
Normal (25C)	782.0	14.6	0.020632	2.5
Extreme (50C)	782.0	13.9	0.019640	2.5
Extreme (40C)	782.0	14.8	0.020849	2.5
Extreme (30C)	782.0	13.8	0.019390	2.5
Extreme (10C)	782.0	14.2	0.020049	2.5
Extreme (0C)	782.0	14.3	0.020161	2.5
Extreme (-10C)	782.0	14.4	0.020265	2.5
Extreme (-20C)	782.0	14.6	0.020526	2.5
Extreme (-30C)	782.0	13.9	0.019630	2.5

Band 13 16QAM, (10MHz BANDWIDTH RB size 50 RB Offset 0)

Frequency error vs. Voltage

Voltage [Vdc]	Frequency [MHz]	Frequency* Error[Hz]	Frequency Error[ppm]	Limit [ppm]
3.4	782.0	12.3	0.017300	2.5
3.8	782.0	13.4	0.018807	2.5
4.4	782.0	13.6	0.019107	2.5

Frequency error vs. Temperature

Temperature [°C]	Frequency [MHz]	Frequency* Error[Hz]	Frequency Error[ppm]	Limit [ppm]
Normal (25C)	782.0	12.5	0.017663	2.5
Extreme (50C)	782.0	11.5	0.016128	2.5
Extreme (40C)	782.0	13.4	0.018880	2.5
Extreme (30C)	782.0	13.1	0.018441	2.5
Extreme (10C)	782.0	14.0	0.019746	2.5
Extreme (0C)	782.0	12.5	0.017552	2.5
Extreme (-10C)	782.0	12.7	0.017941	2.5
Extreme (-20C)	782.0	13.9	0.019633	2.5
Extreme (-30C)	782.0	15.1	0.021303	2.5

***Note:** Frequency error measurements were made by using the build-in capability of the Wireless Communication Test Set.

10.6 LTE BAND 66

QPSK, (20MHz BANDWIDTH)

Frequency error vs. Voltage

Voltage [Vdc]	Frequency [MHz]	Frequency* Error[Hz]	Frequency Error[ppm]	Limit [ppm]
BAND 66 QPSK, (CH 132322 RB size 100 RB Offset 0 20MHz BANDWIDTH)				
3.4	1745	12.4	0.007131	2.5
3.8	1745	13.5	0.007714	2.5
4.4	1745	12.8	0.007348	2.5

Frequency error vs. Temperature

Temperature [°C]	Frequency [MHz]	Frequency* Error[Hz]	Frequency Error[ppm]	Limit [ppm]
BAND 66 QPSK, (CH 132322 RB size 100 RB Offset 0 20MHz BANDWIDTH)				
Normal (25C)	1745	7.5	0.004282	2.5
Extreme (50C)	1745	5.0	0.002878	2.5
Extreme (40C)	1745	5.2	0.002966	2.5
Extreme (30C)	1745	5.1	0.002937	2.5
Extreme (10C)	1745	6.1	0.003480	2.5
Extreme (0C)	1745	5.3	0.003011	2.5
Extreme (-10C)	1745	9.7	0.005554	2.5
Extreme (-20C)	1745	10.4	0.005957	2.5
Extreme (-30C)	1745	6.0	0.003438	2.5

16QAM, (20MHz BANDWIDTH)

Frequency error vs. Voltage

Voltage [Vdc]	Frequency [MHz]	Frequency* Error[Hz]	Frequency Error[ppm]	Limit [ppm]
BAND 66 16QAM, (CH 132322 RB size 100 RB Offset 0 20MHz BANDWIDTH)				
3.4	1745	13.0	0.007468	2.5
3.8	1745	14.2	0.008153	2.5
4.4	1745	12.8	0.007339	2.5

Frequency error vs. Temperature

Temperature [°C]	Frequency [MHz]	Frequency* Error[Hz]	Frequency Error[ppm]	Limit [ppm]
BAND 66 16QAM, (CH 132322 RB size 100 RB Offset 0 20MHz BANDWIDTH)				
Normal (25C)	1745	7.6	0.004372	2.5
Extreme (50C)	1745	4.4	0.002524	2.5
Extreme (40C)	1745	5.8	0.003310	2.5
Extreme (30C)	1745	5.1	0.002947	2.5
Extreme (10C)	1745	6.2	0.003567	2.5
Extreme (0C)	1745	4.8	0.002778	2.5
Extreme (-10C)	1745	9.1	0.005209	2.5
Extreme (-20C)	1745	11.1	0.006359	2.5
Extreme (-30C)	1745	6.5	0.003704	2.5

***Note:** Frequency error measurements were made by using the build-in capability of the Wireless Communication Test Set.

11. Peak-to-Average Ratio

11.1 Description of the PAR Measurement

The peak-to-average ratio (PAR) of the transmission may not exceed 13 dB.

11.2 Measuring Instruments

See list of measuring instruments of this test report.

11.3 Test Procedures

1. The EUT was connected to Spectrum Analyzer and Base Station via power divider.
2. The RF output of EUT was connected to the spectrum analyzer by RF cable and attenuator. The path loss was compensated to the results for each measurement.
3. For GSM/EGPRS operating modes:
 - a. Set the RBW = 1MHz, VBW = 1MHz, Peak detector in spectrum analyzer.
 - b. Set EUT in maximum power output, and triggered the burst signal.
 - c. Measured respectively the Peak level and Mean level, and the deviation was recorded as Peak to Average Ratio.
4. For UMTS operating modes:
 - a. Set the CCDF (Complementary Cumulative Distribution Function) option in spectrum analyzer.
 - b. The highest RF powers were measured and recorded the maximum PAPR level associated with a probability of 0.1 %.

11.4 Test Setup

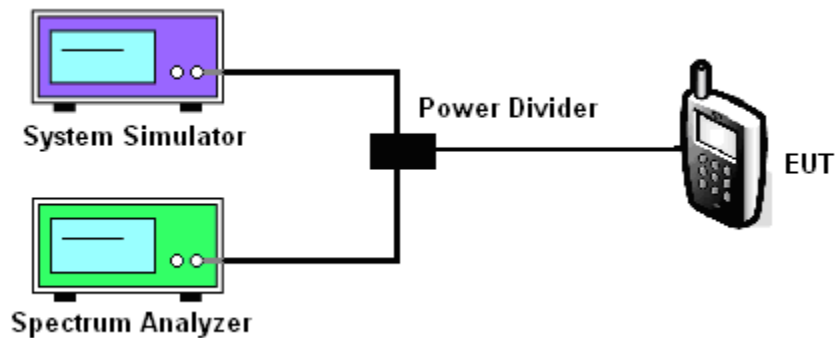

MODES TESTED

- LTE Band2/4/5/7/13/66
-

Test data reference attachment.

----END OF REPORT----