

承 認 書

SPECIFICATION FOR APPROVAL

guest Household:

CUSTOMER:

Customer part number:

CUST P/N:

Taoruan material number:

BESOFTP/N:

Φ20.5x40-9Ts-0.08x24*2P-8mm-CLB

Product model:

DESC:

2023/03/16

day Expect:

DATE:

Version

Book:

A.0

Version:

fictional PREPARED BY	review CHECKED BY	approve APPROVED BY	Customer acknowledges CUSTOMER APPROVE
Feng Boqun	Su Yanping	Qian Limou	

深圳淘软电子有限公司

Factory address: Shangcun, Gongming Street, Guangming District, Shenzhen City

Room 701, Building 10, Area B, Fifth Wing Industrial Zone, Community

TEL:13824883512



SPECIFICATION

Product model: DESC	Φ 20.5x40-9Ts-0.08x24*2P*8mm-CLB	Version Rev:A 0	customerCUST:	
			Taoruan material numberFineP/N:	
			Customer part numberCUST P/N:	

1. SizeDIMENSION:(mm)

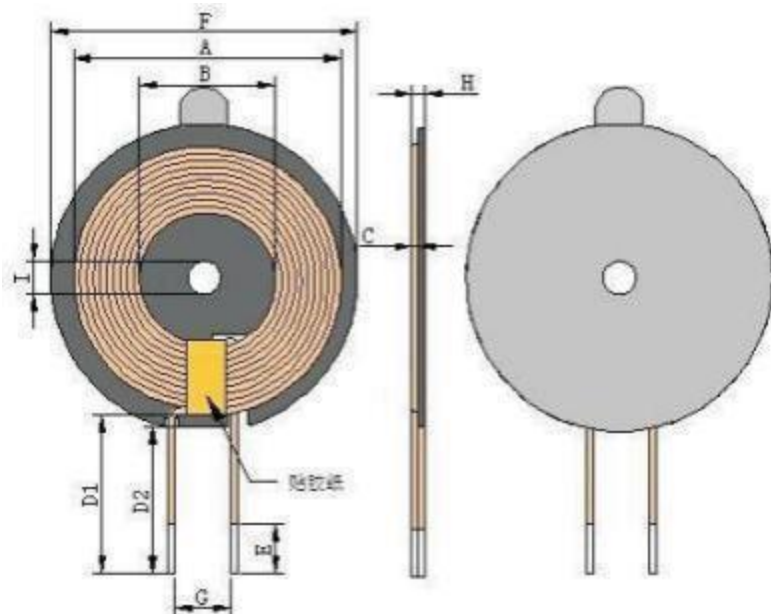

A	40.0±1
B	20.5±0.5
C	0.8±0.05
D1	11±2
D2	8±2
E	3-5mm
F	50±0.5
G	11.0ref
H	1.5±0.2 Max
I	5.3 ref

Note:

- 1.Coil with magnetic sheet, magnetic sheet size 50±0.5mm,Inner hole 5.3mm,Thickness is 0.8±0.1mm,Straight groove
- 2.Coil outlet position winding width 8mm ±0.5 high temperature tape.
- 3.The back of the magnetic sheet has a hand-tearable round shape Diameter 47.5mm(ref), inner hole 7.0 mm (ref)Ordinary double-sided tape.

2. Schematic diagramSCHEMATIC DIAGRAM:

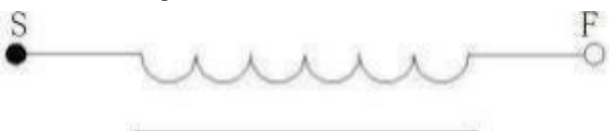

3. Winding parametersWinding Specification:

serial number NO	terminal TERMINAL	Wire diameter WIRE	Number of turns Turns	Winding direction Winding Direction
1	S F	Hot air line0.08*24*2P	9Ts	CCW

4. Electrical characteristicsELECTRICAL CHARACTERISTICS:

temperature TEMPERATURE:25 ± 10 °C,humidityRELATIVE HUMIDITY :65 ±20%

serial number NO	project ITEM	terminal TERMINAL	standard SPECIFICATION	Test Conditions TEST FREQUENCY	test instrument TEST EQUIPMENTS
1	IND.	SF	3.0uH ±20%separate coil	100KHz/1.0V	LCZ METER 1062B
2	IND.	SF	5.5uH±10%Add magnet	100KHz/1.0V	LCZ METER 1062B
3	Qvalue	SF	≤50(ref)Add magnet	100KHz/1.0V	LCZ METER 1062B
4	DCR	SF	≤70mΩ		LCZ METER 502B

Draft/DatePREPARED BY/DATE	Review/DateCHECKED BY/DATE
Feng Boqun2023/03/16	Su Yanping2023/03/16

SPECIFICATION

Product model: DESC	Φ20.5x40-9Ts-0.08x24*2P-8mm-CLB	Version Rev:A 0	customerCUST: Taoruan material numberFineP/N: Customer part numberCUST P/N:
------------------------	--	--------------------	---

5. PackagingPACKONG:

5.1Packaging picturesPacking pictures:

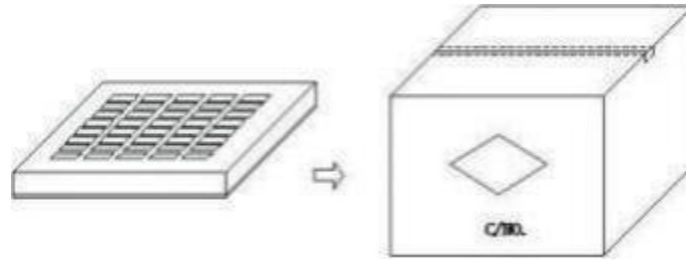

5.2Packaging quantity and specificationsPacking Quantity:

projectItem	quantityQuantity	Material specificationsMaterial
boxBox	350 PCs	370*265*55mm
boxBig Carton	1400 PCs	390*270*245mm

5.3The packaging is based on the existing packaging tray and the actual shipping packaging. It can be customized if there are special requirements.

The packaging shall be based on the existing packing plate and the actual delivery package shall prevail. If there is any requirement, we can customize it.

6. Material listMaterial list:

serial number number	材料名称 Material name	品名描述 Description	制造商 Manufacturer
1	Hot air line0.08*24*2P	Hot air line0.08*24*2P	Dongguan Jinjeyuan Electronic Materials Co., Ltd.
2	Lead-free tin bar	Lead-free tin bar	Shenzhen Daoqin Tin Industry Co., Ltd.
3	magnetic disk	Φ50*5.3*0.8mmManganese zinc hard magnetic sheet	Guangzhou Ruijing New Material Technology Co., Ltd.
4	glue	201glue	Dongguan Feiquan Electronic Materials Co., Ltd.
5	High temperature tape	8mmWide high temperature tape	Dongguan Zhixing Tape New Materials Co., Ltd.
6	Double-sided tape with holes	Round diameter 47.5 with hand tearing positionmm(ref)Adhesive	Shenzhen Hongweida Technology Co., Ltd.

Draft/DatePREPARED BY/DATE	Review/DateCHECKED BY/DATE
Feng Boqun2023/03/16	Su Yanping2023/03/16