



# KSIGN (Guangdong) Testing Co., Ltd.

West Side of 1/F., Building C, Zone A, Fuyuan New Factory, Jiujiu Industrial Park,  
Minzhu, Shatou, Shajing, Bao'an District, Shenzhen, Guangdong, People's Republic of China  
Tel.: + (86)755-29852678 Fax: + (86)755-29852397 E-mail: info@gdkesign.cn Website: www.gdkesign.com

## TEST REPORT

**Report No.** .....: **KS2104S1070E**

**FCC ID**.....: 2AZWD-CRASWW101

**Applicant**.....: **HangZhou Honyar Intelligent Technology Co., Ltd.**

**Address**.....: No. 899,Heting Street,Qingshan Lake Street,Lin'an District, Hangzhou City,Zhejiang Province,China

**Manufacturer**.....: **HangZhou Honyar Intelligent Technology Co., Ltd.**

**Address**.....: No. 899,Heting Street,Qingshan Lake Street,Lin'an District, Hangzhou City,Zhejiang Province,China

**Product Name**.....: **Smart Switch**

**Trade Mark**.....: N/A

**Model/Type reference**.....: CRASWW101

**Listed Model(s)** .....: N/A

**Standard**.....: **FCC CFR Title 47 Part 15 Subpart C Section 15.247**

**Date of receipt of test sample**...: Apr. 27, 2021

**Date of testing**.....: Apr. 27, 2021~May. 11, 2021

**Date of issue**.....: May. 11, 2021

**Test Result**.....: **PASS**

Compiled by:  
(Printed name+signature) Rory Huang

Supervised by:  
(Printed name+signature) Eder Zhan

Approved by:  
(Printed name+signature) Cary Luo



**Testing Laboratory Name**.....: **KSIGN(Guangdong) Testing Co., Ltd.**

**Address**.....: West Side of 1/F., Building C, Zone A, Fuyuan New Factory, Jiujiu Industrial Park, Minzhu, Shatou, Shajing, Bao'an District, Shenzhen, Guangdong, People's Republic of China

This test report may be duplicated completely for legal use with the approval of the applicant. It should not be reproduced except in full, without the written approval of our laboratory. The client should not use it to claim product endorsement by KSIGN. The test results in the report only apply to the tested sample. The test report shall be invalid without all the signatures of testing engineers, reviewer and approver. Any objections must be raised to KSIGN within 15 days since the date when the report is received. It will not be taken into consideration beyond this limit. The test report merely corresponds to the test sample.

**TABLE OF CONTENTS****Page**

<b>TEST SUMMARY.....</b>	<b>3</b>
1.1. TEST STANDARDS.....	3
1.2. REPORT VERSION.....	3
1.3. TEST DESCRIPTION.....	4
1.4. TEST FACILITY.....	5
1.5. MEASUREMENT UNCERTAINTY.....	6
1.6. ENVIRONMENTAL CONDITIONS.....	6
<b>2. GENERAL INFORMATION.....</b>	<b>7</b>
2.1. GENERAL DESCRIPTION OF EUT.....	7
2.2. OPERATION STATE.....	8
2.3. MEASUREMENT INSTRUMENTS LIST.....	9
2.5. TEST SOFTWARE.....	10
<b>3. TEST ITEM AND RESULTS.....</b>	<b>11</b>
3.1. ANTENNA REQUIREMENT.....	11
3.2. PEAK OUTPUT POWER.....	12
3.3. POWER SPECTRAL DENSITY.....	14
3.4. BANDWIDTH.....	23
3.5. BAND EDGE AND SPURIOUS EMISSION (CONDUCTED).....	40
3.6. BAND EDGE EMISSIONS(RADIATED).....	47
3.7. SPURIOUS EMISSION (RADIATED).....	52
3.8. CONDUCTED EMISSION.....	63
<b>4. EUT TEST PHOTOS.....</b>	<b>66</b>
<b>5. PHOTOGRAPHS OF EUT CONSTRUCTIONAL.....</b>	<b>68</b>

## TEST SUMMARY

### 1.1. Test Standards

The tests were performed according to following standards:

**FCC Rules Part 15.247:** Operation within the bands of 902-928MHz, 2400-2483.5MHz, and 5725-5850MHz.

**ANSI C63.10-2013:** American National Standard for Testing Unlicensed Wireless Devices.

**KDB 558074 D01 :** The measurement guidance provided herein is applicable only to Digital Transmission System (DTS) devices operating in the 902-928 MHz, 2400-2483.5 MHz and/or 5725-5850 MHz bands under §15.247 of the FCC rules (Title 47 of the Code of Federal Regulations).

### 1.2. Report version

Revised No.	Date of issue	Description
01	May. 11, 2021	Original

### 1.3. Test Description

FCC Part 15 Subpart C(15.247)			
Test Item	Standard Section	Result	Test Engineer
	FCC		
Antenna Requirement	15.203	Pass	Rory Huang
Conducted Emission	15.207	Pass	Rory Huang
6dB&99% Bandwidth	15.247(a)(2)	Pass	Rory Huang
Peak Output Power	15.247(b)	Pass	Rory Huang
Power Spectral Density	15.247(e)	Pass	Rory Huang
Restricted Band	15.247(d)/15.205	Pass	Rory Huang
Band Edge and Spurious Emission(Conducted)	15.247(d)	Pass	Rory Huang
Spurious Emission(Radiated)	15.247(d)&15.209	Pass	Rory Huang

Note: The measurement uncertainty is not included in the test result.

## 1.4. Test Facility

### Address of the report laboratory

#### **KSIGN(Guangdong) Testing Co., Ltd.**

West Side of 1/F., Building C, Zone A, Fuyuan New Factory, Jiujiu Industrial Park, Minzhu, Shatou, Shajing, Bao'an District, Shenzhen, Guangdong, People's Republic of China

### Laboratory accreditation

The test facility is recognized, certified, or accredited by the following organizations:

#### **CNAS-Lab Code: L13261**

KSIGN(Guangdong) Testing Co., Ltd. has been assessed and proved to be in Compliance with CNAS-CL01 Accreditation Criteria for Testing and Calibration Laboratories (identical to ISO/IEC17025: 2017 General Requirements) for the Competence of Testing and Calibration Laboratories.

#### **A2LA-Lab Cert. No.: 5457.01**

KSIGN(Guangdong) Testing Co., Ltd. EMC Laboratory has been accredited by A2LA for technical competence in the field of electrical testing, and proved to be in compliance with ISO/IEC 17025:2017 General Requirements for the Competence of Testing and Calibration Laboratories and any additional program requirements in the identified field of testing.

#### **IC Registration No.: CN0096**

The 3m alternate test site of KSIGN(Guangdong) Testing Co., Ltd. EMC Laboratory has been registered by Certification and Engineer Bureau of Industry Canada for the performance of with Registration NO.: CN0096

#### **FCC-Registration No.: CN1272**

KSIGN(Guangdong) Testing Co., Ltd. EMC Laboratory has been registered and fully described in a report filed with the (FCC) Federal Communications Commission. The acceptance letter from the FCC is maintained in our files.

### 1.5. Measurement Uncertainty

The data and results referenced in this document are true and accurate. The reader is cautioned that there may be errors within the calibration limits of the equipment and facilities. The measurement uncertainty was calculated for all measurements listed in this test report acc. to TR-100028-01” Electromagnetic compatibility and Radio spectrum Matters (ERM);Uncertainties in the measurement of mobile radio equipment characteristics; Part 1” and TR-100028-02 “Electromagnetic compatibility and Radio spectrum Matters (ERM);Uncertainties in the measurement of mobile radio equipment characteristics; Part 2 “ and is documented in the KSIGN(Guangdong) Testing Co., Ltd. system acc. to DIN EN ISO/IEC 17025. Furthermore, component and process variability of devices similar to that tested may result in additional deviation. The manufacturer has the sole responsibility of continued compliance of the device. Below is the best measurement capability for KSIGN(Guangdong) Testing Co., Ltd.

Test Items	Measurement Uncertainty	Notes
Transmitter power conducted	0.42 dB	(1)
Transmitter power Radiated	2.14 dB	(1)
Conducted spurious emissions 9kHz~40GHz	1.60 dB	(1)
Radiated spurious emissions 9kHz~40GHz	2.20 dB	(1)
Conducted Emissions 9kHz~30MHz	3.20 dB	(1)
Radiated Emissions 30~1000MHz	4.70 dB	(1)
Radiated Emissions 1~18GHz	5.00 dB	(1)
Radiated Emissions 18~40GHz	5.54 dB	(1)
Occupied Bandwidth	2.80 dB	(1)

**Note (1):** This uncertainty represents an expanded uncertainty expressed at approximately the 95% confidence level using a coverage factor of k=1.96.

### 1.6. Environmental conditions

During the measurement the environmental conditions were within the listed ranges:

Temperature:	15~35°C
Relative Humidity:	30~60 %
Air Pressure:	950~1050mba

## 2. GENERAL INFORMATION

### 2.1. General Description of EUT

Test Sample Number:	1-1-1(Normal Sample),1-1-2(Engineering Sample )
Product Name:	Smart Switch
Trade Mark:	N/A
Model/Type reference:	CRASWW101
Listed Model(s):	N/A
Model Different:	N/A
Power supply(Adapter):	INPUT:120V~60Hz MAX OUTPUT:150W LED/CFL 600W Inc/Hal.
Power supply(Battery):	N/A
Hardware version:	V1.0
Software version:	V1.1.3
<b>2.4GHz WIFI</b>	
Modulation:	802.11b: DSSS(CCK, DQPSK, DBPSK) 802.11g/n: OFDM(BPSK,QPSK,16QAM,64QAM)
Operation frequency:	802.11b/g/n(HT20): 2412MHz~2462MHz 802.11n(HT40): 2422MHz~2452MHz
Max Peak Output Power:	802.11b: 14.97 dBm 802.11g: 14.01 dBm 802.11n (HT20): 12.42 dBm 802.11n (HT40): 12.56 dBm
Channel number:	802.11b/g/n(HT20):11 channels 802.11n(HT40):7 channels
Test frequency:	CH01/03: 2412MHz/2422MHz; CH06: 2437MHz; CH09/11: 2452MHz/2462MHz
Channel separation:	5MHz
Antenna type:	PCB Antenna
Antenna gain:	1.5dBi

## 2.2. Operation State

Operation Frequency List: The EUT has been tested under typical operating condition. The Applicant provides communication tools software to control the EUT for staying in continuous transmitting and receiving mode for testing.

Operation Frequency List:

Channel	Frequency (MHz)
01	2412
02	2417
03	2422
04	2427
05	2432
06	2437
07	2442
08	2447
09	2452
10	2457
11	2462

Note: 1.CH 01~CH 11 for 802.11b/g/n(HT20), CH03~CH09 for 802.11n(HT40).

2.The display in grey were the channel selected for testing.

### Test mode

For RF test items
The engineering test program was provided and enabled to make EUT continuous transmit (duty cycle>98%).
For AC power line conducted emissions:
The EUT was set to connect with the WLAN AP under large package sizes transmission.
For Radiated spurious emissions test item:
The engineering test program was provided and enabled to make EUT continuous transmit(duty cycle>98%). The EUT in each of three orthogonal axis emissions had been tested ,but only the worst case (X axis) data Recorded in the report.



### 2.3. Measurement Instruments List

Tonscend JS0806-2 Test system					
Item	Test Equipment	Manufacturer	Model No.	Serial No.	Cal. Until
1	Spectrum Analyzer	R&S	FSV40-N	101798	03/22/2022
2	Vector Signal Generator	Agilent	N5182A	MY50142520	03/18/2022
3	Analog Signal Generator	HP	83752A	3344A00337	03/18/2022
4	Power Sensor	Agilent	E9304A	MY50390009	03/18/2022
5	Power Sensor	Agilent	E9300A	MY41498315	03/18/2022
6	Wideband Radio Communication Tester	R&S	CMW500	157282	03/18/2022
7	Climate Chamber	Angul	AGNH80L	1903042120	03/18/2022
8	Dual Output DC Power Supply	Agilent	E3646A	MY40009992	03/18/2022
9	RF Control Unit	Tonscend	JS0806-2	/	03/18/2022

Transmitter spurious emissions & Receiver spurious emissions					
Item	Test Equipment	Manufacturer	Model No.	Serial No.	Cal. Until
1	EMI Test Receiver	R&S	ESR	102525	03/18/2022
2	High Pass Filter	Chengdu E-Microwave	OHF-3-18-S	0E01901038	03/22/2022
3	High Pass Filter	Chengdu E-Microwave	OHF-6.5-18-S	0E01901039	03/22/2022
4	Spectrum Analyzer	HP	8593E	3831U02087	03/22/2022
5	Ultra-Broadband logarithmic period Antenna	Schwarzbeck	VULB 9163	01230	03/29/2023
6	Loop Antenna	Beijin ZHINAN	ZN30900C	18050	03/27/2022
7	Spectrum Analyzer	R&S	FSV40-N	101798	03/22/2022
8	Horn Antenna	Schwarzbeck	BBHA 9120 D	2023	03/29/2023
9	Pre-Amplifier	Schwarzbeck	BBV 9745	9745#129	03/22/2022
10	Pre-Amplifier	EMCI	EMC051835S E	980662	03/22/2022
11	Pre-Amplifier	Schwarzbeck	BBV-9721	57	04/06/2022
12	Horn Antenna	Schwarzbeck	BBHA 9170	00939	03/28/2022

Item	Test Equipment	Manufacturer	Model No.	Serial No.	Calibrated until
1	LISN	R&S	ENV432	1326.6105.02	03/18/2022
2	EMI Test Receiver	R&S	ESR	102524	03/18/2022
3	Manual RF Switch	JS TOYO	/	MSW-01/002	03/18/2022

Note:

1)The Cal. Interval was one year.

2)The cable loss has calculated in test result which connection between each test instruments.

## 2.5. Test Software

Software name	Model	Version
Conducted emission Measurement Software	EZ-EMC	EMC-Con 3A1.1
Radiated emission Measurement Software	EZ-EMC	FA-03A.2.RE
Bluetooth and WIFI Test System	JS1120-3	2.5.77.0418

### 3. TEST ITEM AND RESULTS

#### 3.1. Antenna requirement

##### Requirement

##### **FCC CFR Title 47 Part 15 Subpart C Section 15.203:**

An intentional radiator shall be designed to ensure that no antenna other than that furnished by the responsible party shall be used with the device. The use of a permanently attached antenna or of an antenna that uses a unique coupling to the intentional radiator, the manufacturer may design the unit so that a broken antenna can be replaced by the user, but the use of a standard antenna jack or electrical connector is prohibited.

##### **FCC CFR Title 47 Part 15 Subpart C Section 15.247(c) (1)(i):**

(i) Systems operating in the 2400~2483.5 MHz band that is used exclusively for fixed. Point-to-point operations may employ transmitting antennas with directional gain greater than 6dBi provided the maximum conducted output power of the intentional radiator is reduced by 1 dB for every 3 dB that the directional gain of the antenna exceeds 6dBi.

##### Test Result

The directional gain of the antenna less than 6dBi, please refer to the EUT internal photographs antenna photo.

Note: The antenna is permanently fixed to the EUT

### 3.2. Peak Output Power

**Limit**

Test Item	Limit	Frequency Range(MHz)
Peak Output Power	1 Watt or 30 dBm	2400~2483.5

**Test Configuration**

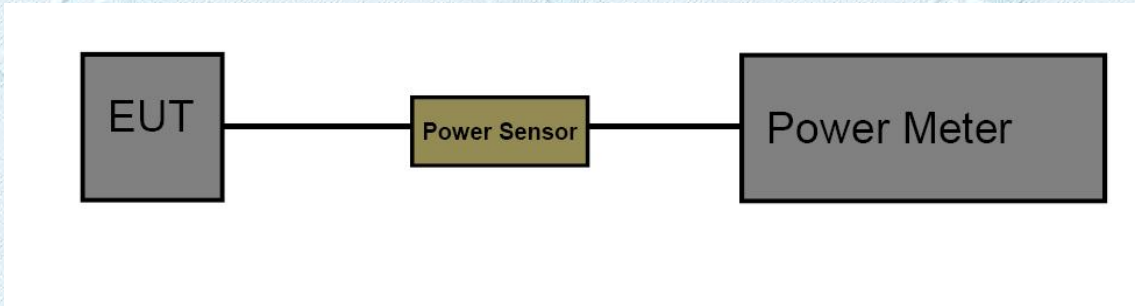

**Test Procedure**

1. Connect EUT RF output port to the Spectrum Analyzer through an RF attenuator.
2. The measurement is according to ANSI C63.10 (2013) for compliance to FCC 47CFR 15.247 requirements.
3. Spectrum Setting:  
 Set analyser center frequency to DTS channel center frequency.  
 Set the RBW to: 1MHz  
 Set the VBW to: 3MHz  
 Detector: peak  
 Sweep time: auto  
 Allow trace to fully stabilize. Then use the peak marker function to determine the maximum amplitude level.
4. The power sensor video bandwidth is greater than or equal to the DTS bandwidth of the equipment.

**Test Mode**

Please refer to the clause 2.2

**Test Result**

Mode	Channel frequency (MHz)	Test Result (dBm)	Limit (dBm)
802.11b	2412	14.97	30
	2437	14.94	
	2462	14.53	
802.11g	2412	14.01	
	2437	13.50	
	2462	12.71	
802.11n (HT20)	2412	11.94	
	2437	12.42	
	2462	11.54	
802.11n (HT40)	2422	12.56	
	2437	12.23	
	2452	12.30	
<b>Result : PASS</b>			

### 3.3. Power Spectral Density

**Limit**

FCC Part 15 Subpart C(15.247)		
Test Item	Limit	Frequency Range(MHz)
Power Spectral Density	8dBm(in any 3 kHz)	2400~2483.5

**Test Configuration**

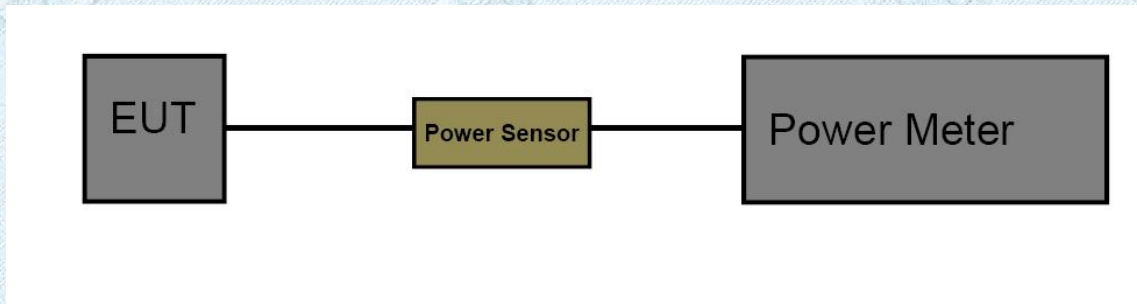

**Test Procedure**

1. Connect EUT RF output port to the Spectrum Analyzer through an RF attenuator.
2. The EUT was directly connected to the Spectrum Analyzer and antenna output port as show in the block diagram above. The measurement according to ANSI C63.10 (2013) for compliance to FCC 47CFR 15.247 requirements.
3. Spectrum Setting:  
 Set analyser center frequency to DTS channel center frequency.  
 Set the span to 1.5 times the DTS bandwidth.  
 Set the RBW to: 10 kHz  
 Set the VBW to: 30 kHz  
 Detector: peak  
 Sweep time: auto  
 Allow trace to fully stabilize. Then use the peak marker function to determine the maximum amplitude level.

**Test Mode**

Please refer to the clause 2.2

**Test Result**

Note:

$$\text{Power Density(dBm/3kHz)} = \text{Power Density(dBm/10kHz)} - 10 * \text{Log}(10/3)$$

<b>Test Mode:</b>	802.11b Mode		
Channel Frequency (MHz)	Power Density (dBm/10kHz)	Power Density (dBm/3kHz)	Limit (dBm)
2412	-5.64	-10.87	8dBm/3kHz
2437	-4.98	-10.21	
2462	-5.39	-10.62	

**2412 MHz**

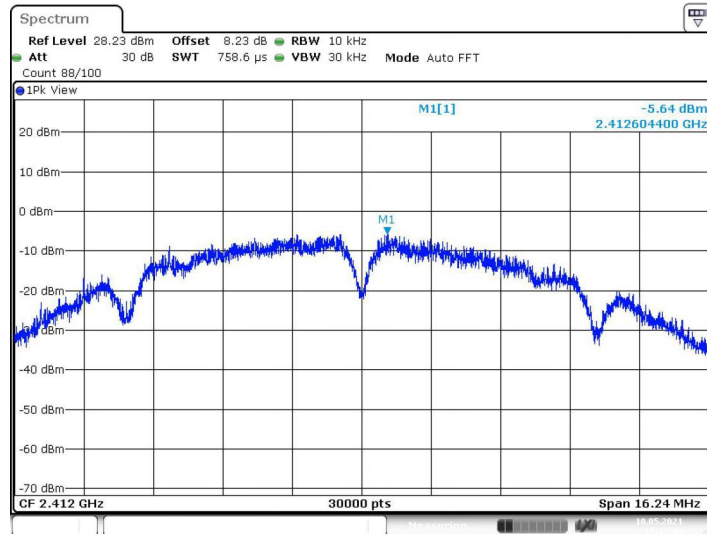

Date: 10.MAY.2021 17:32:47

### 2437 MHz

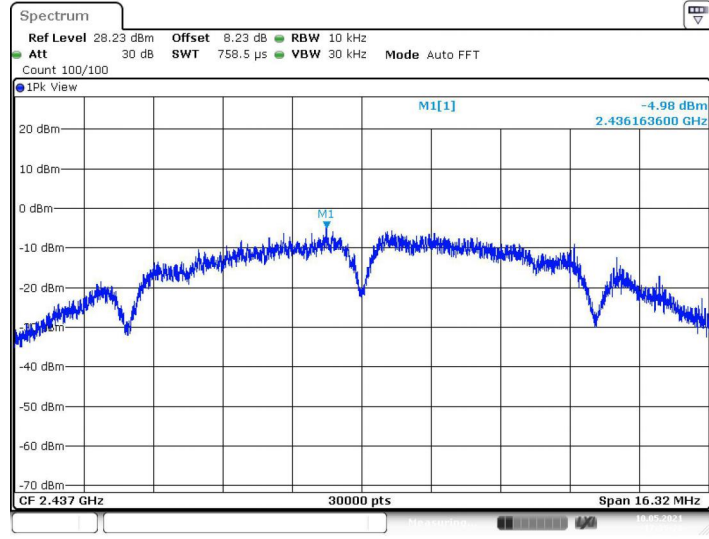

Date: 10.MAY.2021 17:35:28

### 2462 MHz

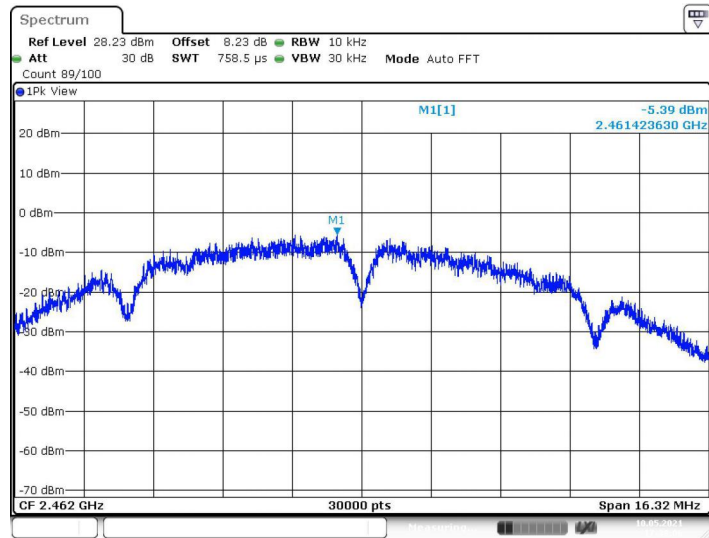

Date: 10.MAY.2021 17:38:07



<b>Test Mode:</b>	802.11g Mode		
Channel Frequency (MHz)	Power Density (dBm/10 kHz)	Power Density (dBm/3 kHz)	Limit (dBm)
2412	-12.04	-17.27	8dBm/3kHz
2437	-13.33	-18.56	
2462	-12.58	-17.81	

**2412 MHz**

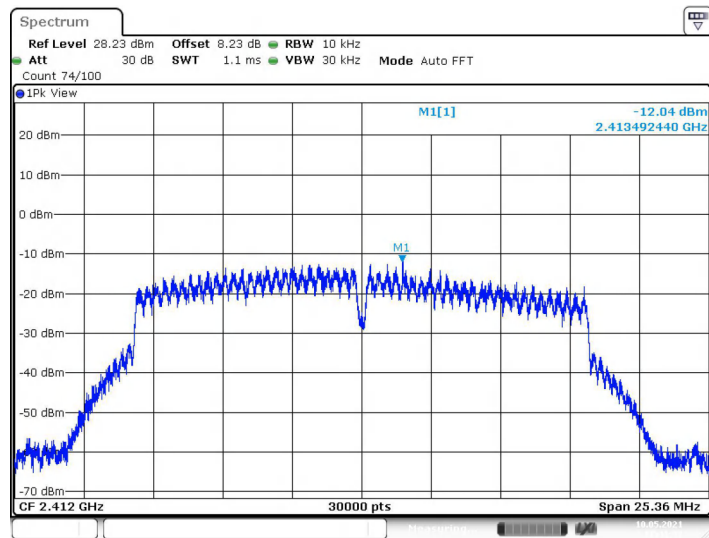

Date: 10.MAY.2021 17:41:32

### 2437 MHz

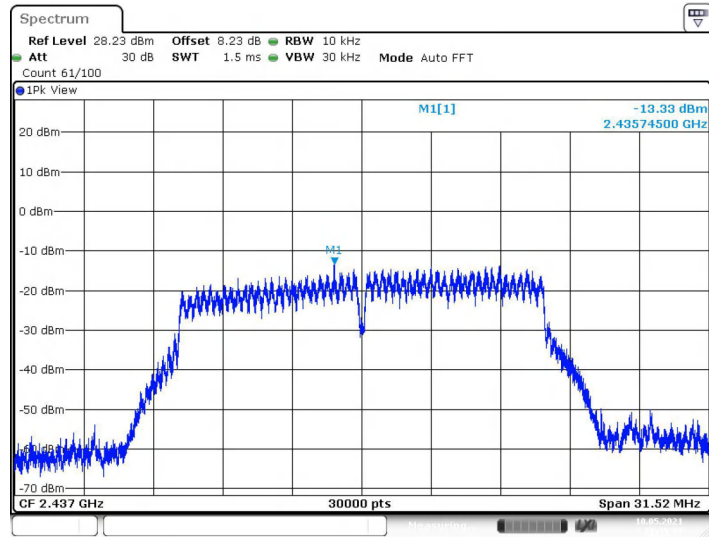

### 2462 MHz

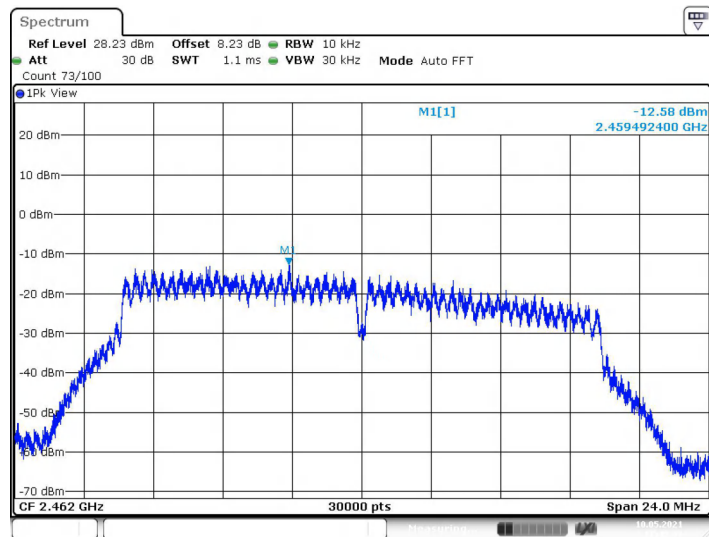

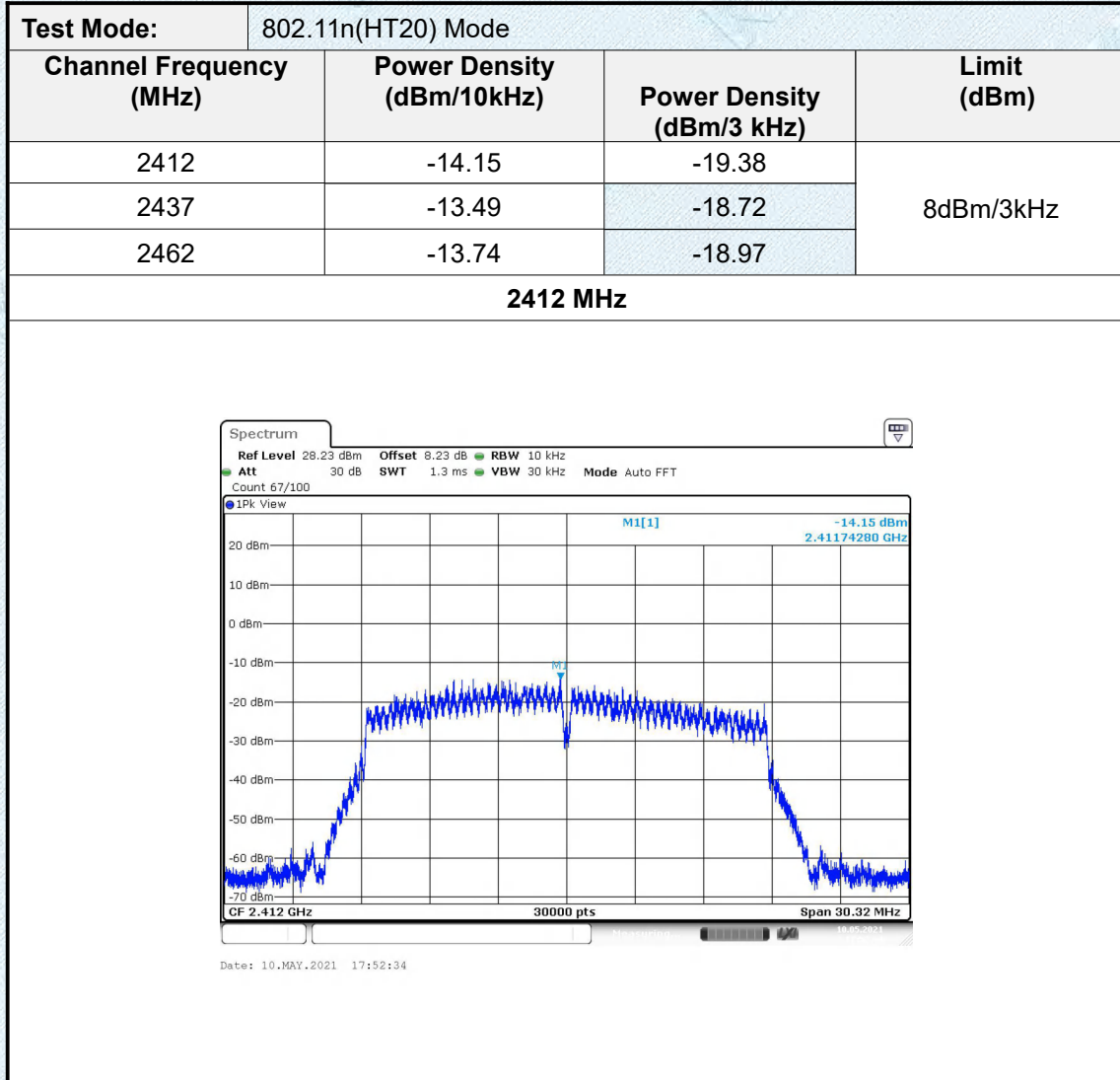

### 2437 MHz

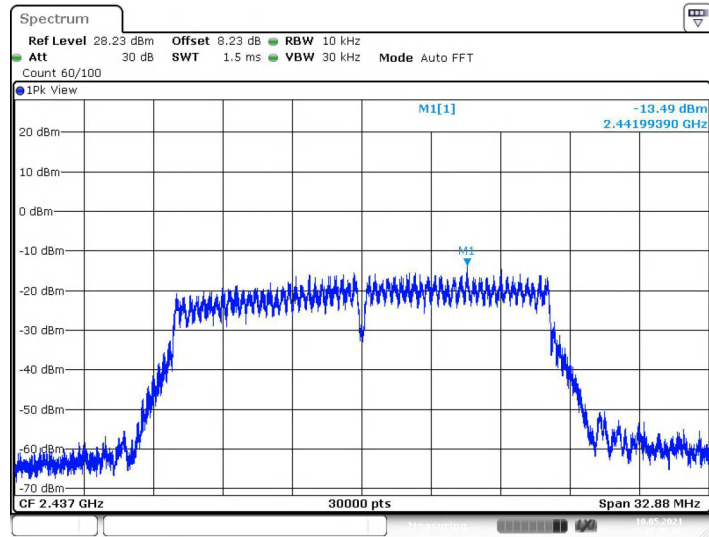

### 2462 MHz

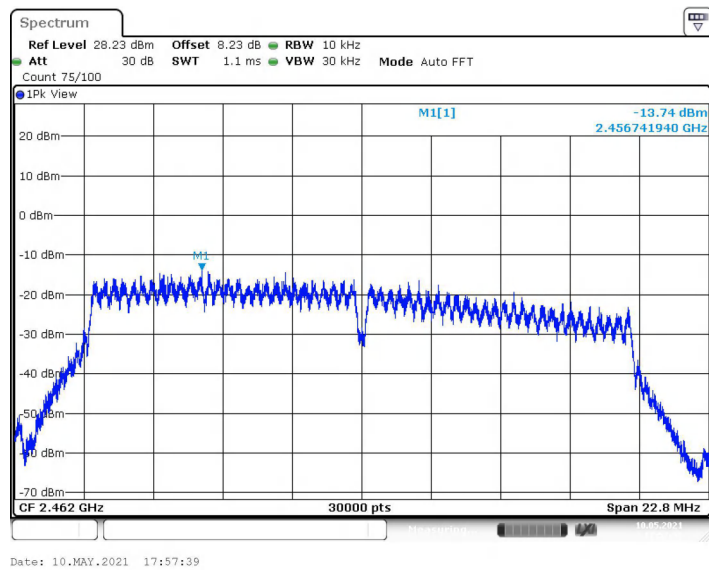

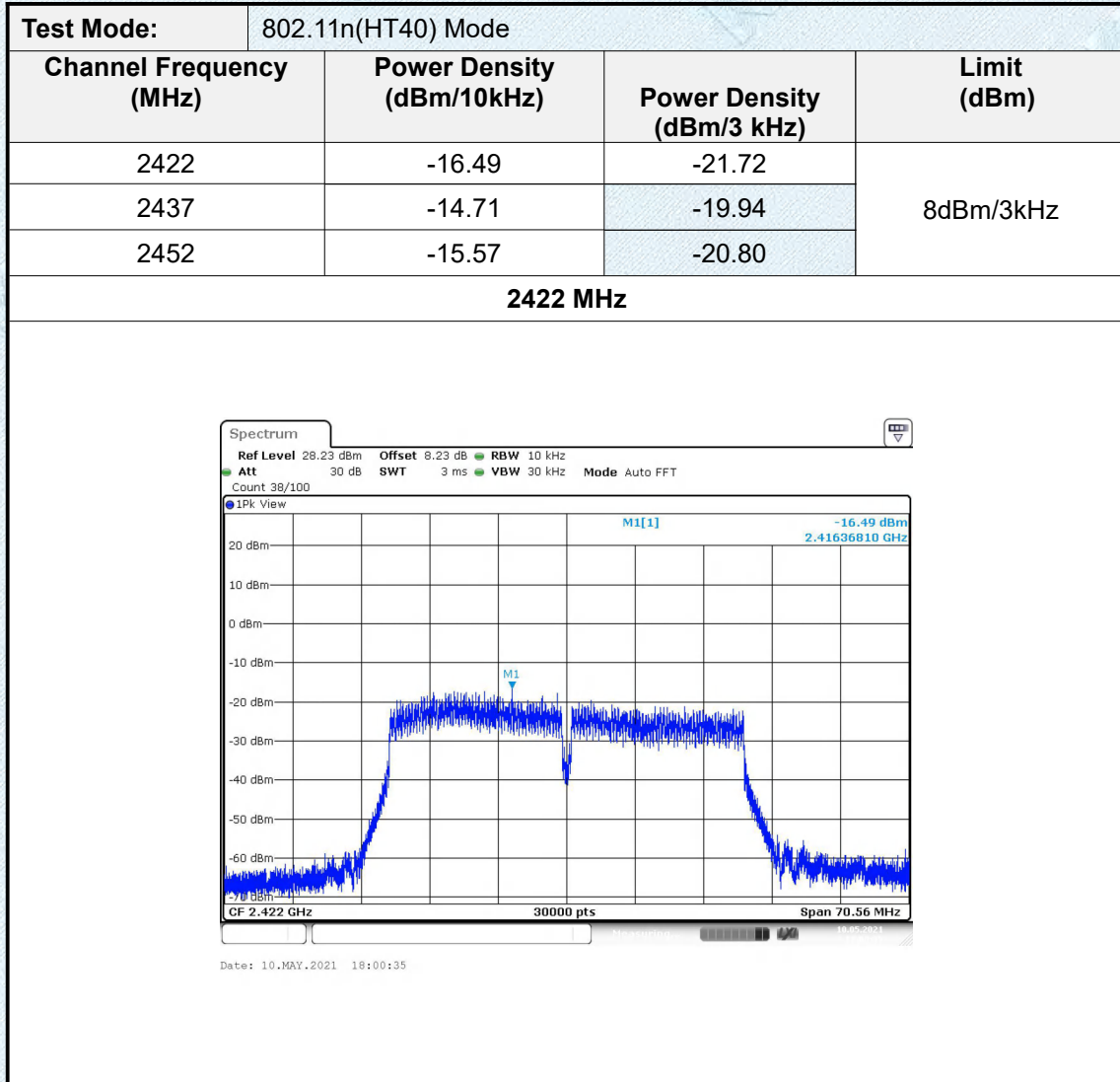

### 2437 MHz

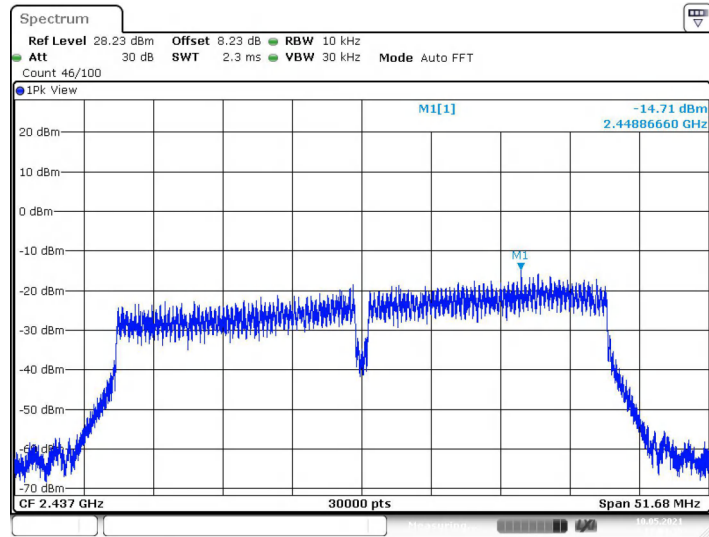

Date: 10.MAY.2021 18:04:25

### 2452 MHz

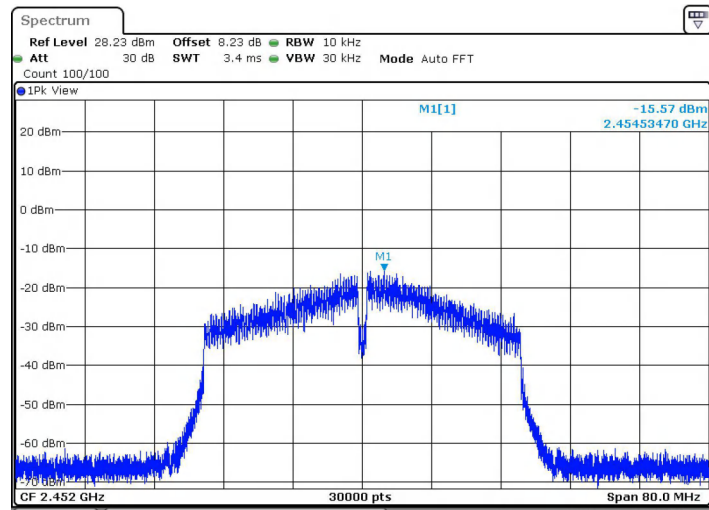

Date: 10.MAY.2021 17:23:31

### 3.4. Bandwidth

**Limit**

Test Item	Limit	Frequency Range(MHz)
Bandwidth	>=500 KHz (6dB bandwidth)	2400~2483.5

**Test Configuration**

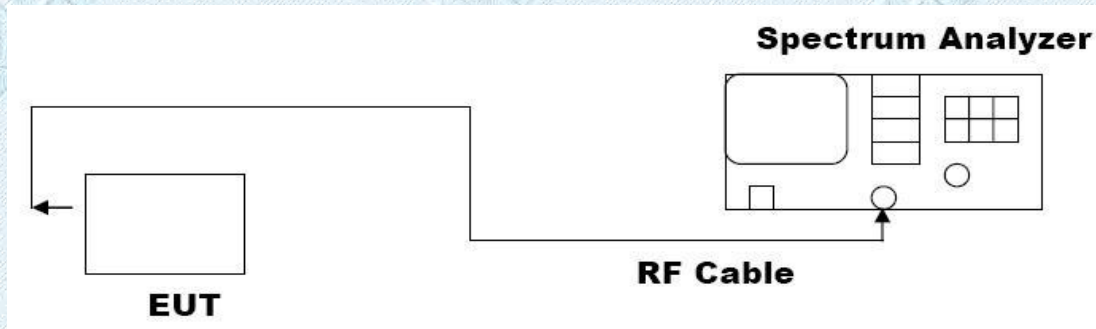

**Test Procedure**

1. Connect EUT RF output port to the Spectrum Analyzer through an RF attenuator:  
6db Bandwidth
  - (1) Set RBW = 100 kHz.
  - (2) Set the video bandwidth (VBW) ≥ 3 RBW.
  - (3) Detector = Peak.
  - (4) Trace mode = Max hold.
  - (5) Sweep = Auto couple.

NOTE: The EUT was set to continuously transmitting in each mode and low, Middle and high channel for the test.

**Test Mode**

Please refer to the clause 2.2.

**Test Results**

<b>Test Mode:</b>	802.11b Mode	
<b>Channel frequency (MHz)</b>	<b>6dB Bandwidth (MHz)</b>	<b>Limit (MHz)</b>
2412	8.120	≥0.5
2437	8.160	
2462	8.160	

**2412 MHz**

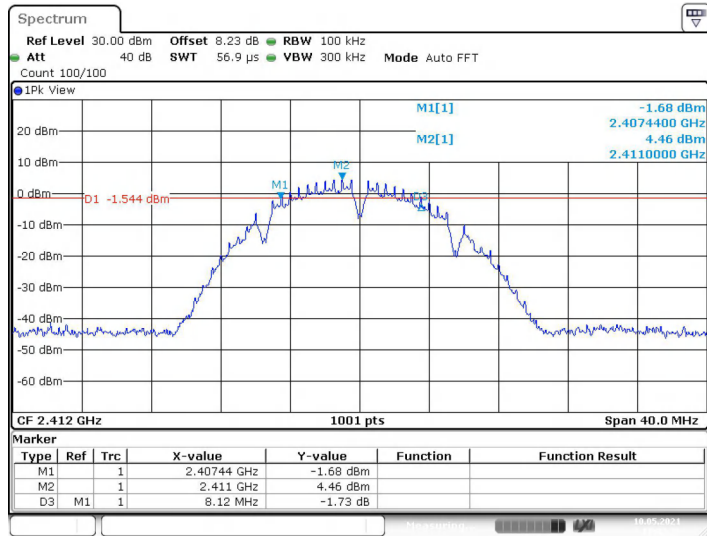

Date: 10.MAY.2021 17:32:24



### 2437 MHz

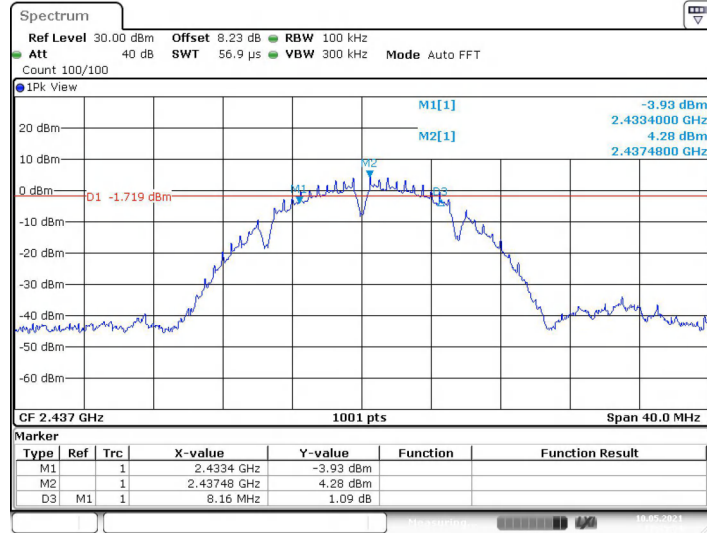

Date: 10.MAY.2021 17:35:04

### 2462 MHz

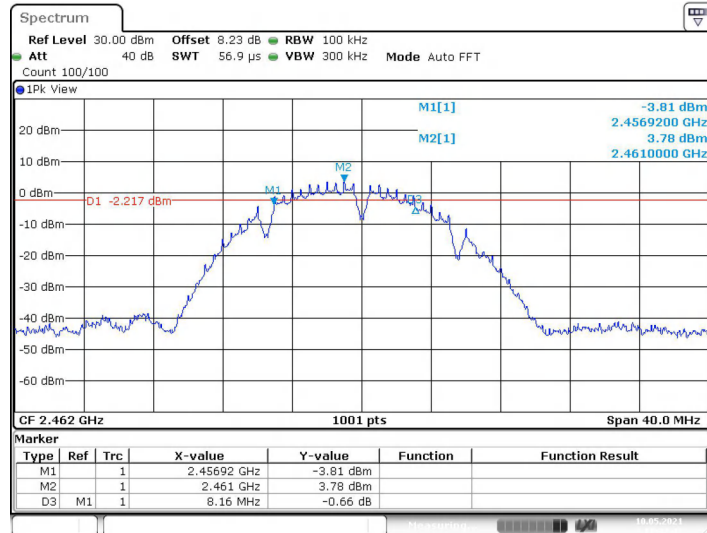

Date: 10.MAY.2021 17:37:43

<b>Test Mode:</b>	802.11g Mode	
<b>Channel frequency (MHz)</b>	<b>6dB Bandwidth (MHz)</b>	<b>Limit (MHz)</b>
2412	12.680	≥0.5
2437	15.760	
2462	12.000	

**2412 MHz**

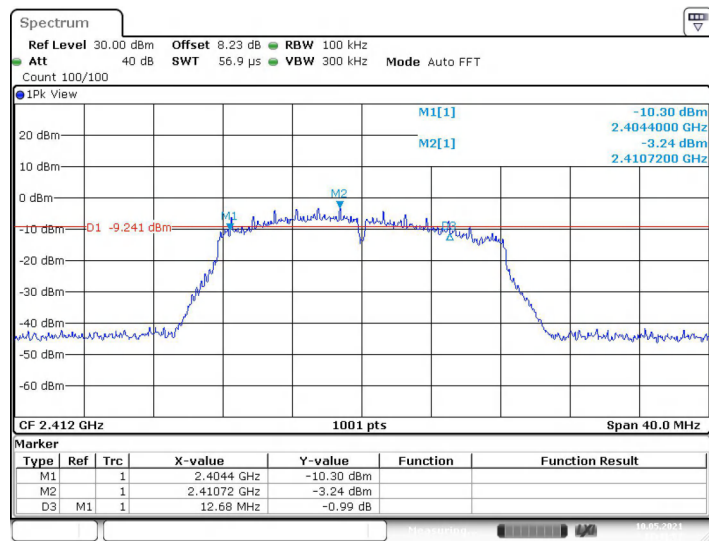

Date: 10.MAY.2021 17:41:08

### 2437 MHz

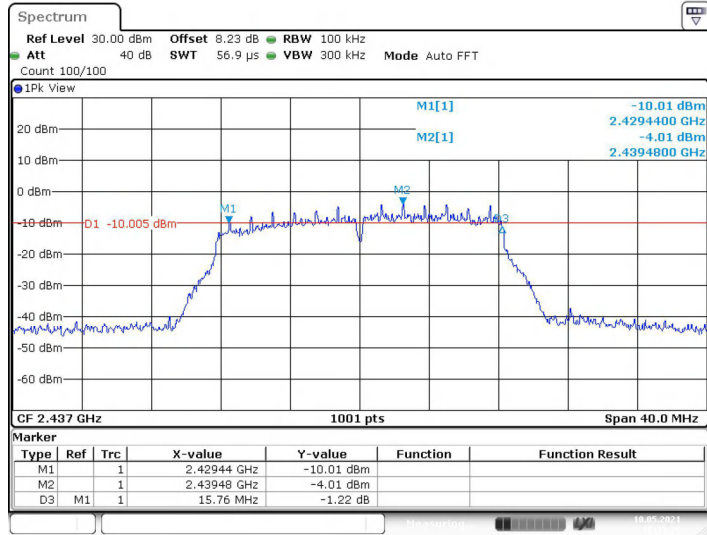

### 2462 MHz

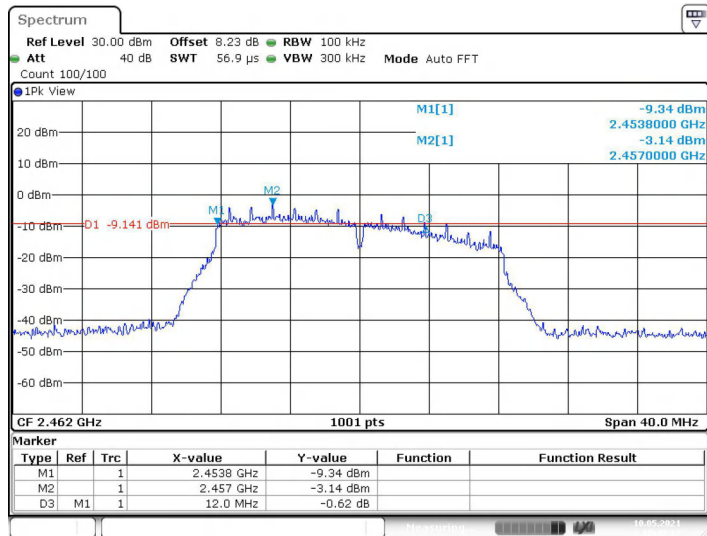

<b>Test Mode:</b>	802.11n(HT20) Mode	
<b>Channel frequency (MHz)</b>	<b>6dB Bandwidth (MHz)</b>	<b>Limit (MHz)</b>
2412	15.160	>=0.5
2437	16.440	
2462	11.400	

**2412 MHz**

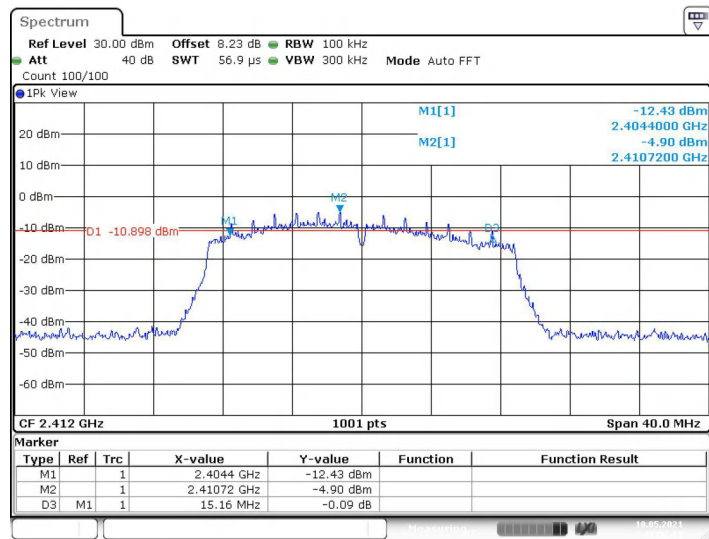

Date: 10.MAY.2021 17:52:10

### 2437 MHz

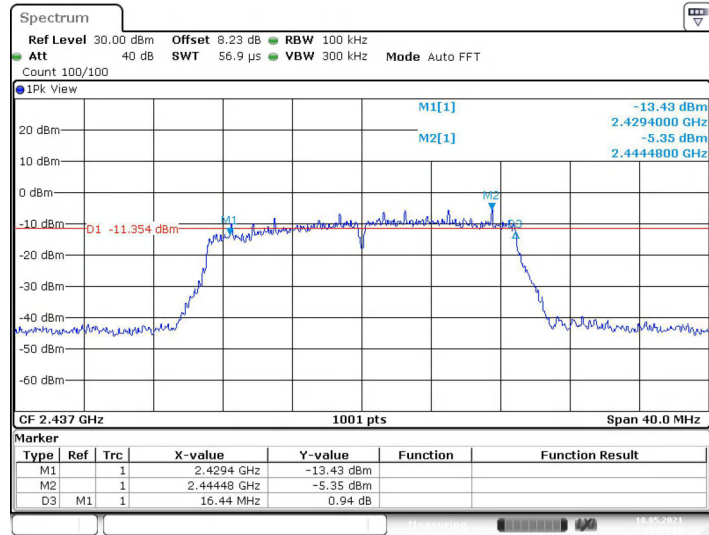

Date: 10.MAY.2021 17:55:16

### 2462 MHz

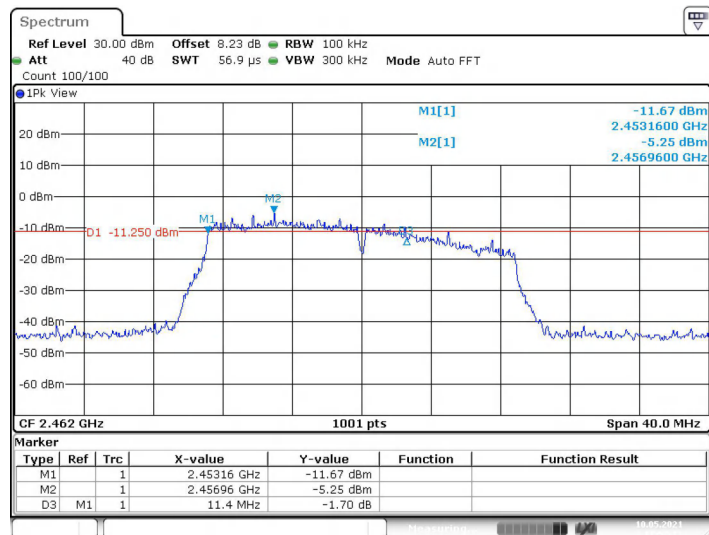

Date: 10.MAY.2021 17:57:15

<b>Test Mode:</b>	802.11n(HT40) Mode	
<b>Channel frequency (MHz)</b>	<b>6dB Bandwidth (MHz)</b>	<b>Limit (MHz)</b>
2422	35.280	≥0.5
2437	25.840	
2452	17.680	

**2422 MHz**

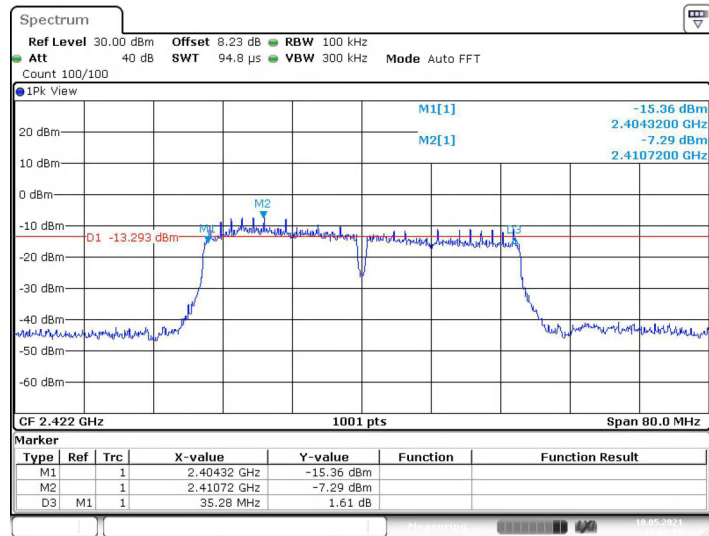

Date: 10.MAY.2021 18:00:11