

# TEST REPORT

**Product Name** : BravoMonster Super RC Car  
**Model Number** : P-201-L-4D  
**FCC ID** : 2AZV7-CAC4DL

**Prepared for** : Beijing Dynamics Technology Co.,LTD  
**Address** : Room 202, Floor 2, Building 23, No.2 North street Jingyuan,  
BDA, Beijing, China

**Prepared by** : EMTEK (SHENZHEN) CO., LTD.  
**Address** : Building 69, Majialong Industry Zone, Nanshan District,  
Shenzhen, Guangdong, China

Tel: (0755) 26954280  
Fax: (0755) 26954282

**Report Number** : ENS2405100158W00501R  
**Date(s) of Tests** : May 15, 2024 to July 11, 2024  
**Date of issue** : July 11, 2024

## Table of Contents

1 TEST RESULT CERTIFICATION .....	3
2 EUT TECHNICAL DESCRIPTION .....	5
3 SUMMARY OF TEST RESULT .....	6
4 TEST METHODOLOGY .....	7
4.1 GENERAL DESCRIPTION OF APPLIED STANDARDS .....	7
4.2 MEASUREMENT EQUIPMENT USED .....	7
4.3 DESCRIPTION OF TEST MODES .....	8
5 FACILITIES AND ACCREDITATIONS .....	9
5.1 FACILITIES .....	9
5.2 EQUIPMENT .....	9
5.3 LABORATORY ACCREDITATIONS AND LISTINGS .....	9
6 TEST SYSTEM UNCERTAINTY .....	10
7 SETUP OF EQUIPMENT UNDER TEST .....	11
7.1 RADIO FREQUENCY TEST SETUP 1 .....	11
7.2 RADIO FREQUENCY TEST SETUP 2 .....	11
7.3 CONDUCTED EMISSION TEST SETUP .....	13
7.4 BLOCK DIAGRAM CONFIGURATION OF TEST SYSTEM .....	14
7.5 SUPPORT EQUIPMENT .....	14
8 TEST REQUIREMENTS .....	15
8.1 20DB&99%BANDWIDTH .....	15
8.2 CARRIER FREQUENCY SEPARATION .....	20
8.3 NUMBER OF HOPPING FREQUENCIES .....	23
8.4 AVERAGE TIME OF OCCUPANCY (DWELL TIME) .....	26
8.5 MAXIMUM PEAK CONDUCTED OUTPUT POWER .....	28
8.6 CONDUCTED SUPRIIOUS EMISSION .....	31
8.7 RADIATED SPURIOUS EMISSION .....	41
8.8 CONDUCTED EMISSION TEST .....	57
8.9 ANTENNA APPLICATION .....	60

# 1 TEST RESULT CERTIFICATION

Applicant : Beijing Dynamics Technology Co.,LTD  
 Address : Room 202, Floor 2, Building 23, No.2 North street Jingyuan, BDA, Beijing, China  
 Manufacturer : Beijing Dynamics Technology Co.,LTD  
 Address : Room 202, Floor 2, Building 23, No.2 North street Jingyuan, BDA, Beijing, China  
 EUT : BravoMonster Super RC Car  
 Model Name : P-201-L-4D  
 Trade Mark : **BRAVOMONSTER**

Measurement Procedure Used:

APPLICABLE STANDARDS	
STANDARD	TEST RESULT
FCC 47 CFR Part 2, Subpart J FCC 47 CFR Part 15, Subpart C	PASS
IC RSS-GEN, Issue 5(04-2018)+A1(03-2019)+A2(02-2021) IC RSS-247 Issue 3(08-2023)	PASS

The above equipment was tested by EMTEK(SHENZHEN) CO., LTD. The test data, data evaluation, test procedures, and equipment configurations shown in this report were made in accordance with the procedures given in ANSI C63.10 (2013) and the energy emitted by the sample EUT tested as described in this report is in compliance with the requirements of FCC Rules Part 2, Part 15.247, IC RSS-247 Issue 3 and IC RSS-GEN, Issue 5.

The test results of this report relate only to the tested sample identified in this report

Date of Test : May 15, 2024 to July 11, 2024

Prepared by :   
 Una Yu /Editor

Reviewer :   
 Joe Xia /Supervisor

Approve & Authorized Signer :   
 Lisa Wang/Manager



### Modified History

Version	Report No.	Revision Date	Summary
Ver.1.0	ENS2405100158W00501R	/	Original Report



## 2 EUT TECHNICAL DESCRIPTION

Characteristics	Description
Product:	BravoMonster Super RC Car
Model Number:	P-201-L-4D
Sample:	2#
Data Rate:	2Mbps for FSK modulation
Modulation:	FSK
Operating Frequency Range(s) :	2405-2475MHz
Number of Channels:	15 channels
Transmit Power Max:	9.55 dBm
Antenna Type:	Internal Antenna
Antenna Gain:	0.21 dBi
Test Voltage:	DC 3.7V from Lithium Battery DC 5V from adapter(Only Charge)
Date of Received:	May 15, 2024
Temperature Range:	0°C ~ +35°C

*Note: for more details, please refer to the User's manual of the EUT.*

### 3 SUMMARY OF TEST RESULT

FCC Part Clause	IC Part Clause	Test Parameter	Verdict	Remark
15.247(a)(1)	RSS-247.5.1 RSS-Gen.6.7	Emission Bandwidth	PASS	
15.247(a)(1)	RSS-247.5.1	Carrier Frequency Separation	PASS	
15.247(a)(1)	RSS-247.5.1	Number of Hopping Frequencies	PASS	
15.247(a)(1)	RSS-247.5.1	Average Time of Occupancy (Dwell Time)	PASS	
15.247(b)(1)	RSS-247.5.4 RSS-Gen 6.12	Maximum Peak Conducted Output Power	PASS	
15.247(d)	RSS-247.5.5	Conducted Spurious Emissions	PASS	
15.247(d) 15.209 15.205	RSS-Gen 8.9 RSS-Gen 8.10 RSS-Gen 6.13 RSS-247.3.3 RSS-247.5.5	Radiated Spurious Emissions	PASS	
15.207	RSS-Gen 8.8	Conducted Emission	PASS	
15.203 15.247(b)	RSS-Gen 6.8 RSS-247.5.4	Antenna Application	PASS	
15.247 (a) (1)/g/h	-	Frequency Hopping System	PASS	
<p>NOTE1: N/A (Not Applicable)</p> <p>NOTE2: According to FCC OET KDB 558074, the report use radiated measurements in the restricted frequency bands. In addition, the radiated test is also performed to ensure the emissions emanating from the device cabinet also comply with the applicable limits.</p> <p>NOTE3: The time on the test data photo is wrong, The correct test time is as described on the report.If there is fraud, Our laboratory assumes full responsibility.</p>				

RELATED SUBMITTAL(S) / GRANT(S):

This submittal(s) (test report) is intended for **FCC ID:2AZV7-CAC4DL** filing to comply with Section 15.247 of the FCC Part 15, Subpart C Rules.

## 4 TEST METHODOLOGY

### 4.1 GENERAL DESCRIPTION OF APPLIED STANDARDS

According to its specifications, the EUT must comply with the requirements of the following standards:

FCC 47 CFR Part 2, Subpart J

FCC 47 CFR Part 15, Subpart C

IC RSS-GEN, Issue 5(04-2018)+A1(03-2019)+A2(02-2021)

IC RSS-247 Issue 3(02-2023)

FCC KDB 558074 D01 15.247 Meas Guidance v05r02

### 4.2 MEASUREMENT EQUIPMENT USED

#### Conducted Emission Test Equipment

Equipment	Manufacturer	Model No.	Serial No.	Last Cal.	Cal. Interval
EMI Test Receiver	Rohde & Schwarz	ESCI	101384	2024/5/11	1Year
AMN	Rohde & Schwarz	ENV216	101161	2024/5/10	1Year

#### For Spurious Emissions Test

Equipment	Manufacturer	Model No.	Serial No.	Last Cal.	Cal. Interval
Pre-Amplifier	Bonn	BLMA 011001N	2213967A	2023/10/23	1Year
EMI Test Receiver	Rohde & Schwarz	ESR7	102551	2023/10/23	1Year
Bilog Antenna	Schwarzbeck	VULB9163	9163142	2022/7/24	2Year
Horn antenna	Schwarzbeck	BBHA9120D	9120D-1198	2023/6/2	2Year
Pre-Amplifier	Bonn	BLMA 0118-5G	2213967B-01	2023/10/23	1Year
Spectrum Analyzer	Rohde & Schwarz	FSV3044	101290	2023/10/23	1Year
Horn antenna	Schwarzbeck	BBHA9170	9170-399	2023/5/12	2Year
Pre-Amplifier	Lunar EM	LNA18G26-40	J101213101000 1	2024/5/11	1Year
Pre-Amplifier	Lunar EM	LNA26G40-40	J101313102800 1	2024/5/11	1Year

#### For other test items:

Equipment	Manufacturer	Model No.	Serial No.	Last Cal.	Cal. Interval
Wideband Radio Communication Tester	R&S	CMW500	171168	2023/9/14	1Year
Spectrum Analyzer	R&S	FSV3044	101289	2023/9/14	1Year
Analog Signal Generator	R&S	SMB100A	183237	2023/9/16	1Year
Vector Signal Generator	R&S	SMM100A	101808	2023/9/16	1Year
RF Control Unit(Power Meter)	Tonscend	JS0806-2	22C8060567	2023/9/14	1Year
Temperature&Humidity Chamber	ESPEC	EL-02KA	12107166	2024/5/10	1 Year

### 4.3 DESCRIPTION OF TEST MODES

The EUT has been tested under its typical operating condition.

The EUT configuration for testing is installed on RF field strength measurement to meet the Commissions requirement and operating in a manner which intends to maximize its emission characteristics in a continuous normal application.

The Transmitter was operated in the normal operating mode. The TX frequency was fixed which was for the purpose of the measurements.

Test of channel included the lowest and middle and highest frequency to perform the test, then record on this report.

Those data rates (2Mbps for FSK modulation) were used for all test.

Pre-defined engineering program for regulatory testing used to control the EUT for staying in continuous transmitting and receiving mode is programmed.

Frequency and Channel list :

Channel	Frequency (MHz)	Channel	Frequency (MHz)	Channel	Frequency (MHz)
1	2405	6	2430	11	2455
2	2410	7	2435	12	2460
3	2415	8	2440	13	2465
4	2420	9	2445	14	2470
5	2425	10	2450	15	2475

Test Frequency and channel :

Lowest Frequency		Middle Frequency		Highest Frequency	
Channel	Frequency (MHz)	Channel	Frequency (MHz)	Channel	Frequency (MHz)
1	2405	8	2440	15	2475



## 5 FACILITIES AND ACCREDITATIONS

### 5.1 FACILITIES

All measurement facilities used to collect the measurement data are located at:

EMTEK (Shenzhen) Co., Ltd.

Building 69, Majialong Industry Zone District, Nanshan District, Shenzhen, China

The sites are constructed in conformance with the requirements of ANSI C63.7, ANSI C63.4 and CISPR Publication 22.

### 5.2 EQUIPMENT

Radiated emissions are measured with one or more of the following types of linearly polarized antennas: tuned dipole, biconical, log periodic, bi-log, and/or ridged waveguide, horn. Spectrum analyzers with preselectors and quasi-peak detectors are used to perform radiated measurements.

Conducted emissions are measured with Line Impedance Stabilization Networks and EMI Test Receivers.

Calibrated wideband preamplifiers, coaxial cables, and coaxial attenuators are also used for making measurements.

All receiving equipment conforms to CISPR Publication 16-1, "Radio Interference Measuring Apparatus and Measurement Methods."

### 5.3 LABORATORY ACCREDITATIONS AND LISTINGS

Site Description	
EMC Lab.	<p><b>: Accredited by CNAS</b>                      The Certificate Registration Number is L2291.                      The Laboratory has been assessed and proved to be in compliance with CNAS-CL01 (identical to ISO/IEC 17025:2017)</p> <p><b>Accredited by FCC</b>                      Designation Number: CN1204                      Test Firm Registration Number: 882943</p> <p><b>Accredited by A2LA</b>                      The Certificate Number is 4321.01.</p> <p>Accredited by Industry Canada                      The Conformity Assessment Body Identifier is CN0008</p>
Name of Firm	: EMTEK (SHENZHEN) CO., LTD.
Site Location	: Building 69, Majialong Industry Zone, Nanshan District, Shenzhen, Guangdong, China

## 6 TEST SYSTEM UNCERTAINTY

The following measurement uncertainty levels have been estimated for tests performed on the apparatus:

Test Parameter	Measurement Uncertainty
Frequency error	$\pm 20\text{Hz}$
Occupied Bandwidth	$\pm 0.5\text{KHz}$
Transmitter output power	$\pm 0.6\text{dB}$
Conducted spurious emissions	$\pm 3.2\text{dB}$
Radiated spurious emissions	$\pm 4.5\text{dB}$
Temperature	$\pm 1.2^\circ\text{C}$
Humidity	$\pm 3\%$
DC voltages	$\pm 0.25\text{V}$
Time	$\pm 1\%$

Measurement Uncertainty for a level of Confidence of 95%



## 7 SETUP OF EQUIPMENT UNDER TEST

### 7.1 RADIO FREQUENCY TEST SETUP 1

The Bluetooth component's antenna port(s) of the EUT are connected to the measurement instrument per an appropriate attenuator. The EUT is controlled by PC/software to emit the specified signals for the purpose of measurements.

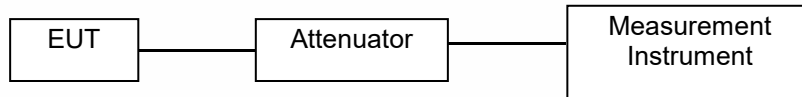

### 7.2 RADIO FREQUENCY TEST SETUP 2

The test site semi-anechoic chamber has met the requirement of NSA tolerance 4 dB according to the standards: ANSI C63.10. The test distance is 3m. The setup is according to the requirements in Section 13.1.4.1 of ANSI C63.10-2013 and CAN/CSA-CEI/IEC CISPR 22.

Below 30MHz:

The EUT is placed on a turntable 0.8meters above the ground in the chamber, 3 meter away from the antenna (loop antenna). The Antenna should be positioned with its plane vertical at the specified distance from the EUT and rotated about its vertical axis for maximum response at each azimuth about the EUT. The center of the loop shall be 1 m above the ground. For certain applications, the loop antenna plane may also need to be positioned horizontally at the specified distance from the EUT.

Above 30MHz:

The EUT is placed on a turntable 0.8meters above the ground in the chamber, 3 meter away from the antenna. The maximal emission value is acquired by adjusting the antenna height, polarisation and turntable azimuth. Normally, the height range of antenna is 1 m to 4 m, the azimuth range of turntable is 0° to 360°, and the receive antenna has two polarizations Vertical (V) and Horizontal (H).

Above 1GHz:

(Note: the FCC's permission to use 1.5m as an alternative per TCBC Conf call of Dec. 2, 2014.)

The EUT is placed on a turntable 1.5 meters above the ground in the chamber, 3 meter away from the antenna. The maximal emission value is acquired by adjusting the antenna height, polarisation and turntable azimuth. Normally, the height range of antenna is 1 m to 4 m, the azimuth range of turntable is 0° to 360°, and the receive antenna has two polarizations Vertical (V) and Horizontal (H).

(a) Radiated Emission Test Set-Up, Frequency Below 30MHz

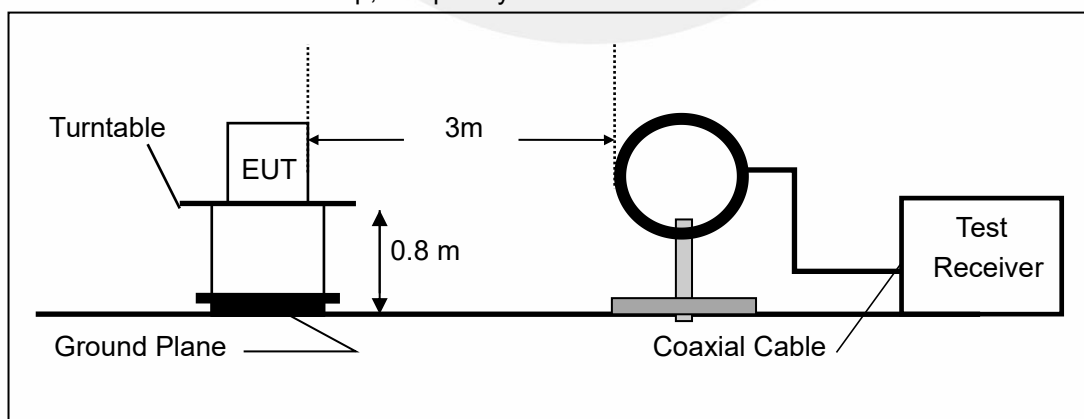

(b) Radiated Emission Test Set-Up, Frequency Below 1000MHz

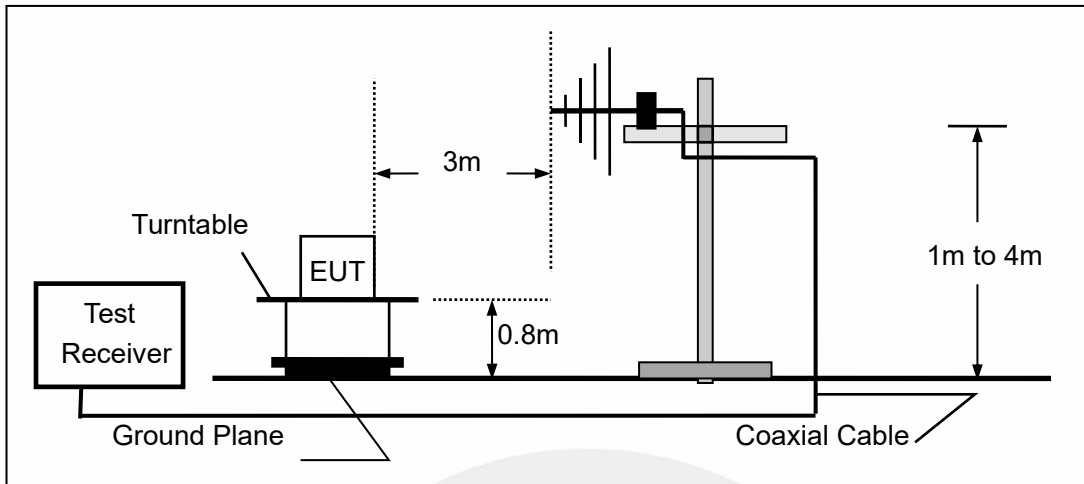

(c) Radiated Emission Test Set-Up, Frequency above 1000MHz

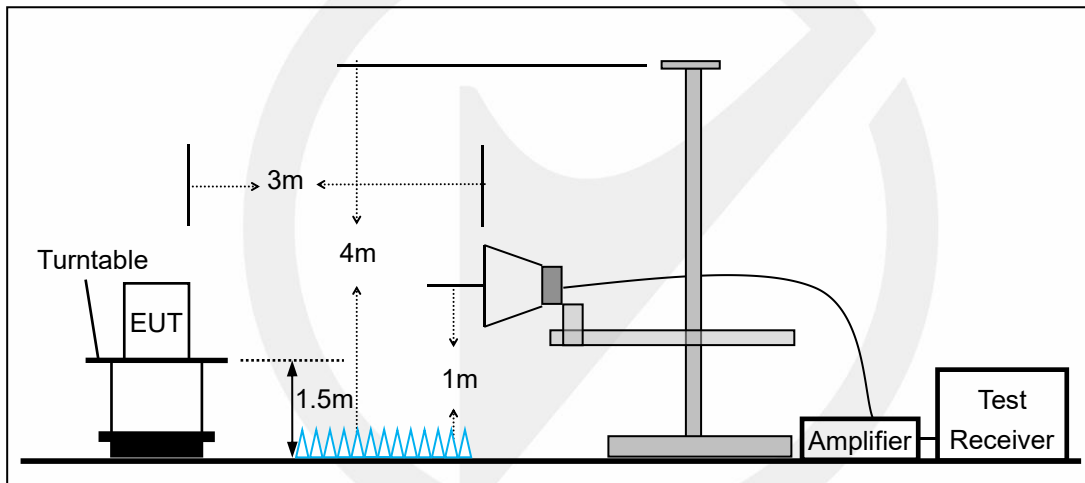

### 7.3 CONDUCTED EMISSION TEST SETUP

The mains cable of the EUT (Perfect Share Mini) must be connected to LISN. The LISN shall be placed 0.8m from the boundary of EUT and bonded to a ground reference plane for LISN mounted on top of the ground reference plane. This distance is between the closest points of the LISN and the EUT. All other units of the EUT and associated equipment shall be at least 0.8m from the LISN.

Ground connections, where required for safety purposes, shall be connected to the reference ground point of the LISN and, where not otherwise provided or specified by the manufacturer, shall be of same length as the mains cable and run parallel to the mains connection at a separation distance of not more than 0.8m.

According to the requirements in Section 13.1.4.1 of ANSI C63.10-2013 Conducted emissions from the EUT measured in the frequency range between 0.15 MHz and 30 MHz using CISPR Quasi-Peak and average detector mode.

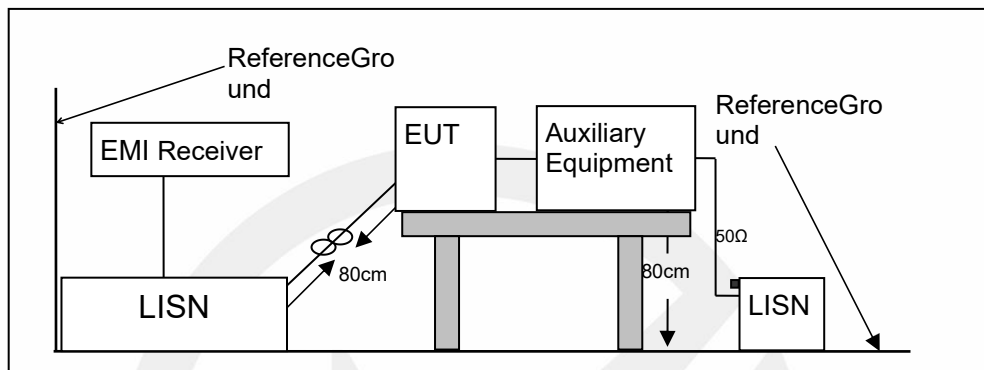

#### 7.4 BLOCK DIAGRAM CONFIGURATION OF TEST SYSTEM

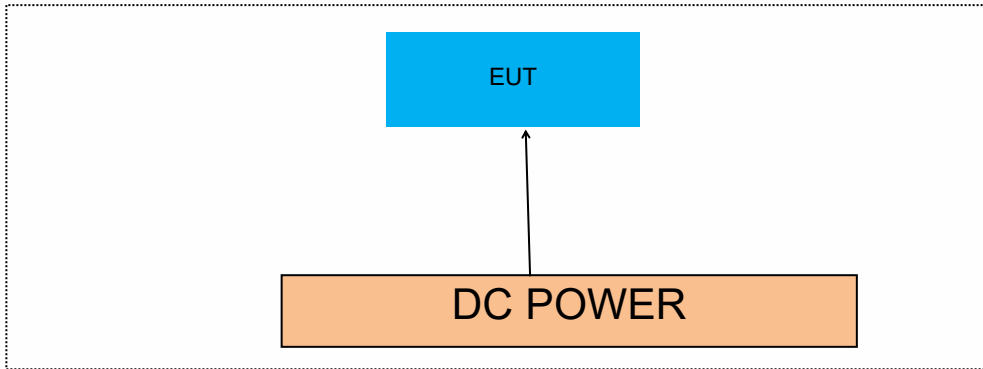

#### 7.5 SUPPORT EQUIPMENT

EUT Cable List and Details			
Cable Description	Length (m)	Shielded/Unshielded	With / Without Ferrite
/	/	/	/

Auxiliary Cable List and Details			
Cable Description	Length (m)	Shielded/Unshielded	With / Without Ferrite
/	/	/	/

Auxiliary Equipment List and Details			
Description	Manufacturer	Model	Serial Number
/	/	/	/

**Notes:**

1. All the equipment/cables were placed in the worst-case configuration to maximize the emission during the test.
2. Grounding was established in accordance with the manufacturer's requirements and conditions for the intended use.

## 8 TEST REQUIREMENTS

### 8.1 20DB&99%BANDWIDTH

#### 8.1.1 Applicable Standard

According to FCC Part 15.247(a)(1) and KDB 558074 D01 15.247 MEAS GUIDANCE v05r02  
According to IC RSS-247.5.1 and RSS-Gen.6.7

#### 8.1.2 Conformance Limit

No limit requirement.

#### 8.1.3 Test Configuration

Test according to clause 7.1 radio frequency test setup 1

#### 8.1.4 Test Procedure

The EUT was operating in Bluetooth mode and controlled its channel. Printed out the test result from the spectrum by hard copy function.

The RF output of EUT was connected to the spectrum analyzer by RF cable and attenuator. The path loss was compensated to the results for each measurement.

Set to the maximum power setting and enable the EUT transmit continuously

Set RBW = 30 kHz.

Set the video bandwidth (VBW) = 100 kHz.

Set Span = approximately 2 to 3 times the 20 dB bandwidth

Set Detector = Peak.

Set Trace mode = max hold.

Set Sweep = auto couple.

The EUT should be transmitting at its maximum data rate. Allow the trace to stabilize. Use the marker-to-peak function to set the marker to the peak of the emission. Use the marker-delta function to measure 20 dB down one side of the emission. Reset the marker-delta function, and move the marker to the other side of the emission, until it is (as close as possible to) even with the reference marker level. The marker-delta reading at this point is the 20 dB bandwidth of the emission.

If this value varies with different modes of operation (e.g., data rate, modulation format, etc.), repeat this test for each variation.

Measure and record the results in the test report.

#### Test Results

Temperature:	25° C
Relative Humidity:	45%
ATM Pressure:	1011 mbar

Note: N/A

20dB Emission Bandwidth

TestMode	Antenna	Frequency[MHz]	20db EBW[MHz]	FL[MHz]	FH[MHz]	Limit[MHz]	Verdict
FSK	Ant1	2405	2.097	2403.956	2406.053	---	---
		2440	2.178	2438.953	2441.131	---	---
		2475	2.097	2473.956	2476.053	---	---





## FSK Ant1\_2405



## FSK Ant1\_2440



## FSK Ant1\_2475



## Occupied Channel Bandwidth

TestMode	Antenna	Frequency[MHz]	OCB [MHz]	FL[MHz]	FH[MHz]	Limit[MHz]	Verdict
FSK	Ant1	2405	2.0672	2403.9745	2406.0417	---	---
		2440	2.0673	2438.9793	2441.0466	---	---
		2475	2.0750	2473.9730	2476.0480	---	---



## FSK Ant1 2405



## FSK Ant1 2440



## FSK Ant1 2475



## 8.2 CARRIER FREQUENCY SEPARATION

### 8.2.1 Applicable Standard

According to FCC Part 15.247(a)(1) and KDB 558074 D01 15.247 MEAS GUIDANCE v05r02  
 According to IC RSS-247.5.1

### 8.2.2 Conformance Limit

Frequency hopping systems operating in the 2400-2483.5MHz band shall have hopping channel carrier frequencies separated by a minimum of 25kHz or the 20dB bandwidth of the hopping channel, whichever is greater.

In case of an output power less than 125mW, the frequency hopping system may have channels separated by a minimum of 25kHz or two-thirds of the 20dB bandwidth of the hopping channel, whichever is greater.

### 8.2.3 Test Configuration

Test according to clause 7.1 radio frequency test setup 1

### 8.2.4 Test Procedure

The EUT must have its hopping function enabled. Use the following spectrum analyzer settings:

Set the RBW =300kHz. Set VBW =300kHz.

Set the span = wide enough to capture the peaks of two adjacent channels

Set Sweep time = auto couple.

Set Detector = peak. Set Trace mode = max hold.

Allow the trace to stabilize. Use the marker-delta function to determine the separation between the peaks of the adjacent channels. The limit is specified in one of the subparagraphs of this Section. Submit this plot.

### Test Results

Temperature:	25° C
Relative Humidity:	45%
ATM Pressure:	1011 mbar

Note: For FSK Limit = 20dB bandwidth \* 2/3

TestMode	Antenna	Frequency[MHz]	Result[MHz]	Limit[MHz]	Verdict
FSK	Ant1	Hop_2405	5.00	≥1.398	PASS
		Hop_2440	4.98	≥1.452	PASS
		Hop_2475	4.96	≥1.398	PASS



## FSK Ant1 Hop 2405

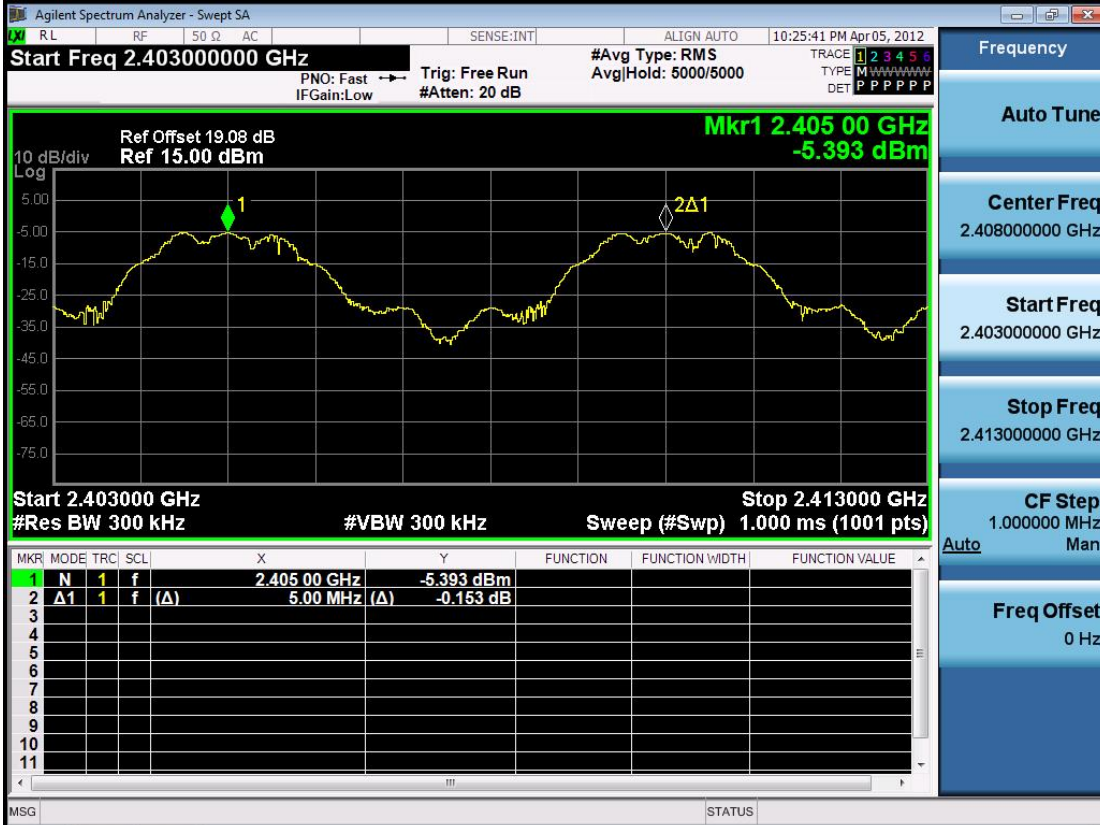

## FSK Ant1 Hop 2440



## FSK Ant1 Hop 2475





### 8.3 NUMBER OF HOPPING FREQUENCIES

#### 8.3.1 Applicable Standard

According to FCC Part 15.247(a)(1) and KDB 558074 D01 15.247 MEAS GUIDANCE v05r02  
 According to IC RSS-247.5.1

#### 8.3.2 Conformance Limit

Frequency hopping systems operating in the 2400-2483.5MHz band shall use at least 15 channels.

#### 8.3.3 Test Configuration

Test according to clause 7.1 radio frequency test setup 1

#### 8.3.4 Test Procedure

The EUT must have its hopping function enabled. Use the following spectrum analyzer settings:

Span = the frequency band of operation (2400-2483.5MHz)

RBW = 300KHz

VBW ≥ RBW

Sweep = auto

Detector function = peak

Trace = max hold

Allow the trace to stabilize. It may prove necessary to break the span up to sections, in order to clearly show all of the hopping frequencies.

#### Test Results

Temperature:	25° C
Relative Humidity:	45%
ATM Pressure:	1011 mbar

Note: N/A

TestMode	Antenna	Frequency[MHz]	Result[Num]	Limit[Num]	Verdict
FSK	Ant1	Hop	15	≥15	PASS

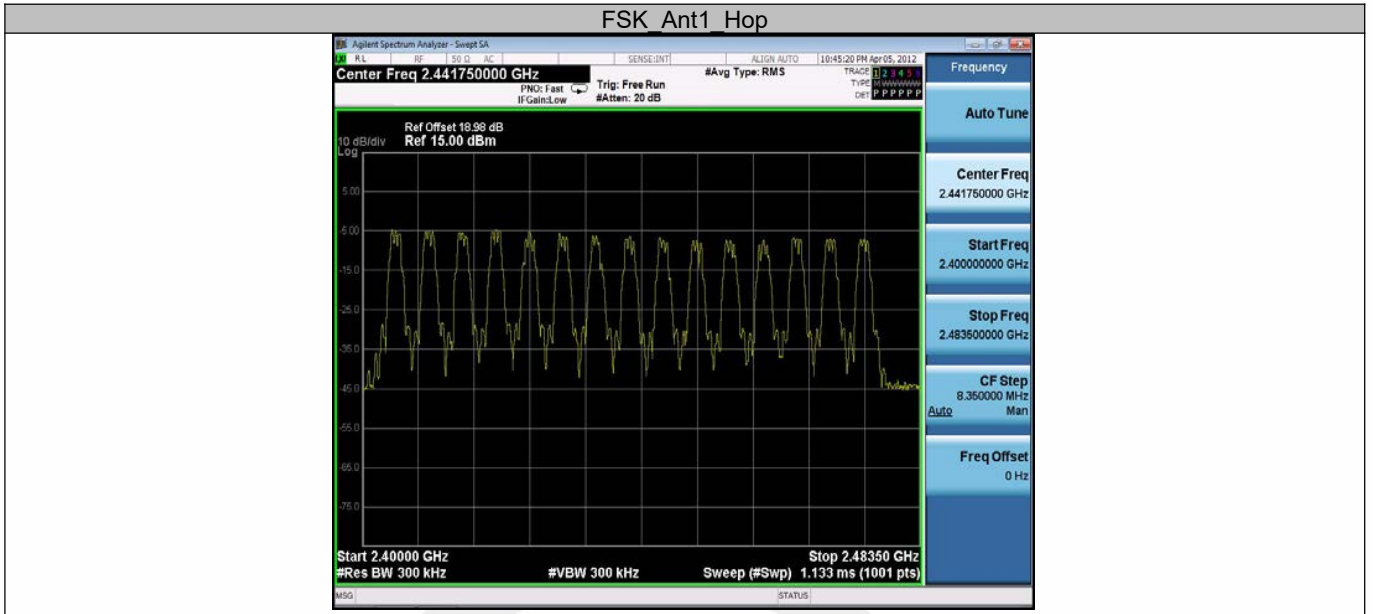

## 8.4 AVERAGE TIME OF OCCUPANCY (DWELL TIME)

### 8.4.1 Applicable Standard

According to FCC Part 15.247(a)(1) and KDB 558074 D01 15.247 MEAS GUIDANCE v05r02  
 According to IC RSS-247.5.1

### 8.4.2 Conformance Limit

For frequency hopping systems operating in the 2400-2483.5MHz band, the averagetime of occupancy on any channel shall not be greater than 0.4s within a period of 0.4smultiplied by the number of hopping channels employed.

### 8.4.3 Test Configuration

Test according to clause 7.1 radio frequency test setup 1

### 8.4.4 Test Procedure

The EUT must have its hopping function enabled. Use the following spectrum analyzersettings:

Span = zero span, centered on a hopping channel

RBW = 1 MHz

VBW ≥ RBW

Sweep = as necessary to capture the entire dwell time per hopping channel

Detector function = peak

Trace = max hold

If possible, use the marker-delta function to determine the dwell time. If this value varies with different modes of operation (e.g., data rate, modulation format, etc.), repeat this test for each variation. The limit is specified in one of the subparagraphsof this Section.

### 8.4.5 Test Results

Temperature:	25° C
Relative Humidity:	45%
ATM Pressure:	1011 mbar

All modes (low, mid, high channels) were tested, the data of the worst mode are described in the following pages.

TestMode	Antenna	Frequency[MHz]	BurstWidth [ms]	Result[s]	Limit[s]	Verdict
FSK	Ant1	2440MHz	0.160	0.064	≤0.4	PASS

Note:

occupied time for each channel

0.00016\*10(s)

Dwell time for 0.4 second

0.00016\*10\*40=0.064(s)

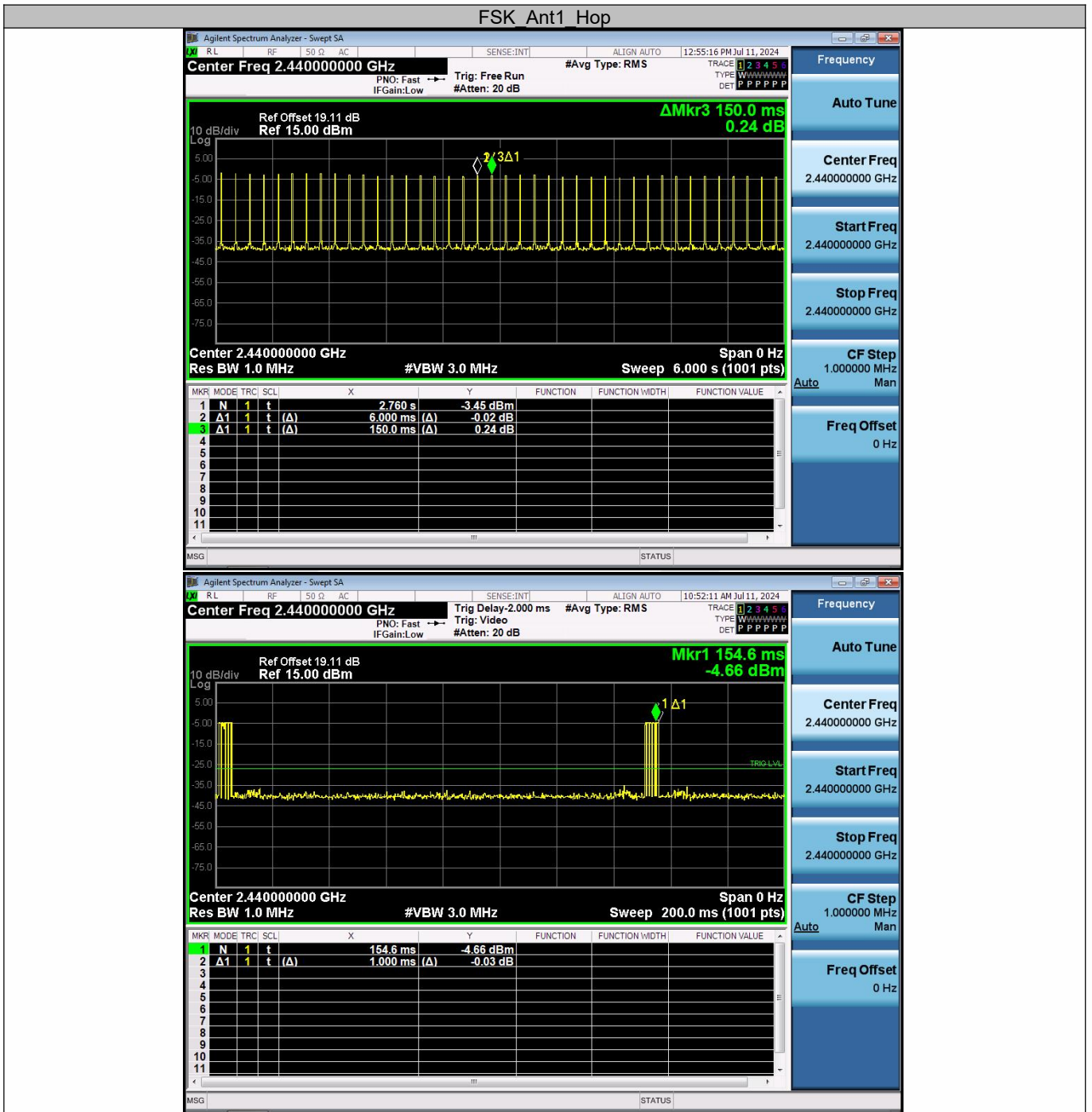

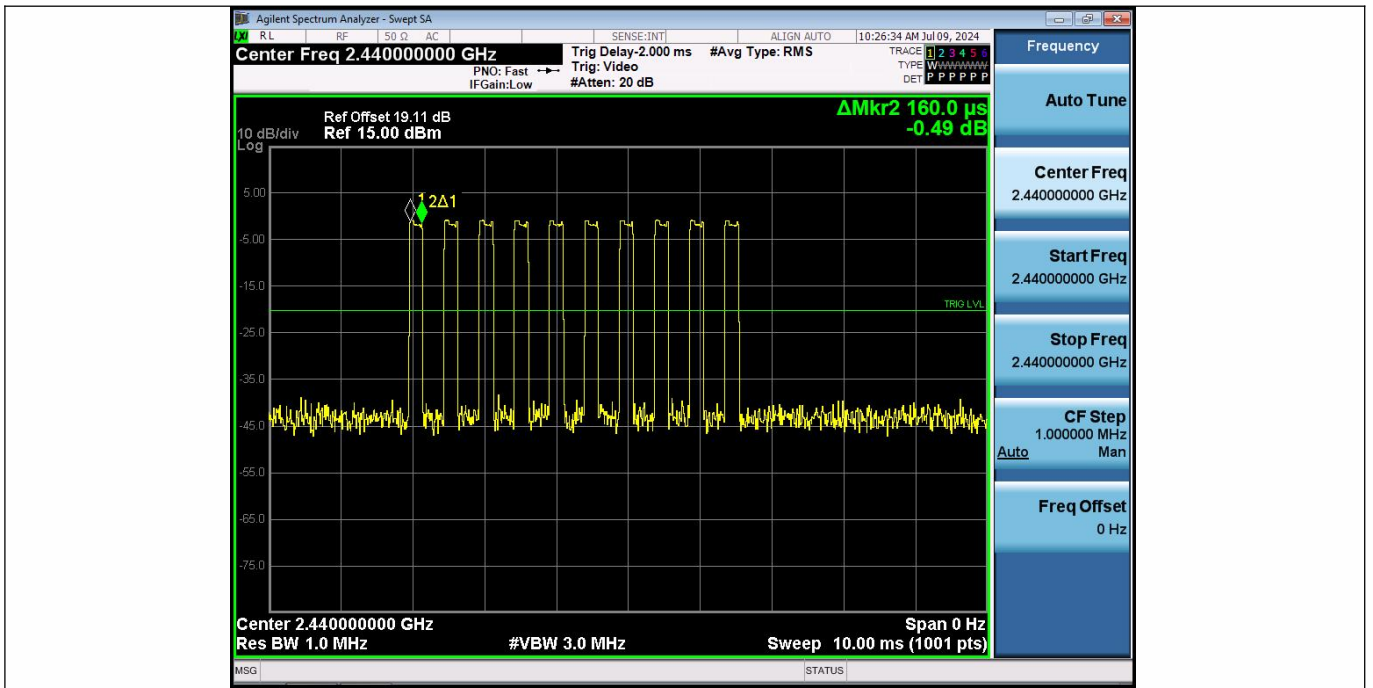

## 8.5 MAXIMUM PEAK CONDUCTED OUTPUT POWER

### 8.5.1 Applicable Standard

According to FCC Part 15.247(b)(1) and KDB 558074 D01 15.247 MEAS GUIDANCE v05r02  
 According to IC RSS-247.5.4 and RSS-Gen 6.12

### 8.5.2 Conformance Limit

The max For frequency hopping systems operating in the 2400-2483.5 MHz band employing at least 75 non-overlapping hopping channels: 1 watt. For all other frequency hopping systems in the 2400-2483.5 MHz band: 0.125 watts.

### 8.5.3 Test Configuration

Test according to clause 7.1 radio frequency test setup 1

### 8.5.4 Test Procedure

As an alternative to a peak power measurement, compliance with the limit can be based on a measurement of the maximum conducted output power.

Use the following spectrum analyzer settings:

Set Span = approximately 5 times the 20 dB bandwidth, centered on a hopping channel(about 8MHz)

Set RBW > the 20 dB bandwidth of the emission being measured(about 3MHz)

Set VBW ≥ RBW

Set Sweep = auto

Set Detector function = peak

Set Trace = max hold

Allow the trace to stabilize. Use the marker-to-peak function to set the marker to the peak of the emission to determine the peak amplitude level.

### Test Results

Temperature:	25° C
Relative Humidity:	45%
ATM Pressure:	1011 mbar

Note: N/A

Test Mode	Antenna	Frequency[MHz]	Conducted Peak Power[dBm]	Conducted Limit[dBm]	Verdict
FSK	Ant1	2405	9.06	≤20.97	PASS
		2440	9.11	≤20.97	PASS
		2475	9.55	≤20.97	PASS

## FSK\_Ant1\_2405

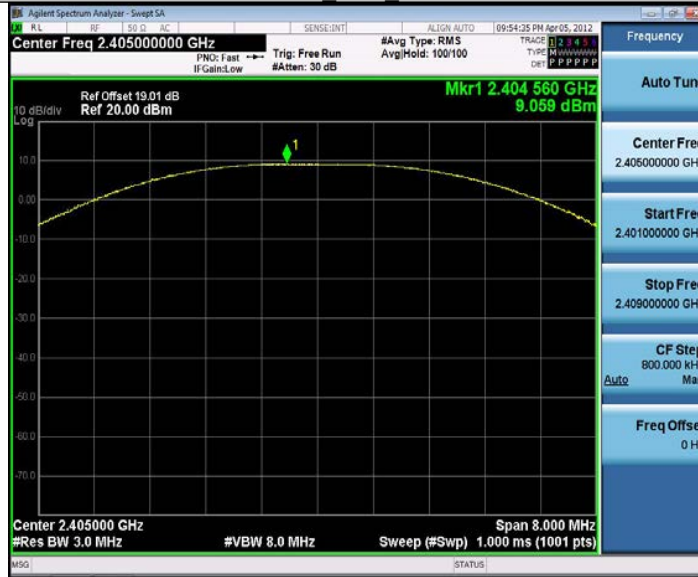

## FSK\_Ant1\_2440



## FSK\_Ant1\_2475







## 8.6 CONDUCTED SUPRIIOUS EMISSION

### 8.6.1 Applicable Standard

According to FCC Part 15.247(d) and KDB 558074 D01 15.247 MEAS GUIDANCE v05r02  
According to IC RSS-247.5.5

### 8.6.2 Conformance Limit

In any 100 kHz bandwidth outside the frequency band in which the spread spectrum intentional radiator is operating, the radio frequency power that is produced by the intentional radiator shall be at least 20 dB below that in the 100 kHz bandwidth within the band that contains the highest level of the desired power, based on either an RF conducted, provided the transmitter demonstrates compliance with the peak conducted power limits.

### 8.6.3 Test Configuration

Test according to clause 7.1 radio frequency test setup 1

### 8.6.4 Test Procedure

The transmitter output (antenna port) was connected to the spectrum analyzer

#### ■ Reference level measurement

Establish a reference level by using the following procedure:

Set instrument center frequency to DSS channel center frequency.

Set Span = approximately 5 times the 20 dB bandwidth, centered on a hopping channel.

Set the RBW = 100 kHz. Set the VBW  $\geq 3 \times$  RBW.

Set Detector = peak. Set Sweep time = auto couple.

Set Trace mode = max hold. Allow trace to fully stabilize.

Use the peak marker function to determine the maximum Maximumconducedlevel.

Note that the channel found to contain the maximum conduced level can be used to establish the reference level.

#### ■ Band-edge measurement

Use the following spectrum analyzer settings:

Span = wide enough to capture the peak level of the emission operating on the channel closest to the band-edge, as well as any modulation products which fall outside of the authorized band of operation

Set RBW  $\geq 1\%$  of the span=100kHzSet VBW  $\geq 3 \times$  RBW

Set Sweep = autoSet Detector function = peakSet Trace = max hold

Allow the trace to stabilize. Set the marker on the emission at the bandedge, or on the highest modulation product outside of the band, if this level is greater than that at the bandedge. Enable the marker-delta function, then use the marker-to-peak function to move the marker to the peak of the in-band emission. The marker-delta value now displayed must comply with the limit specified in this Section.

Now, using the same instrument settings, enable the hopping function of the EUT. Allow the trace to stabilize.

Follow the same procedure listed above to determine if any spurious emissions caused by the hopping function also comply with the specified limit.

#### ■ Emission level measurement

Use the following spectrum analyzer settings:

Span = wide enough to capture the peak level of the in-band emission and all spurious emissions (e.g., harmonics) from the lowest frequency generated in the EUT up through the 10th harmonic.(30MHz to 25GHz).Set RBW = 100 kHzSet VBW  $\geq$  RBW

Set Sweep = autoSet Detector function = peakSet Trace = max hold

Allow the trace to stabilize. Set the marker on the peak of any spurious emission recorded. The level displayed must comply with the limit specified in this Section.

### 8.6.5 Test Results

Temperature:	25°C
Relative Humidity:	45%
ATM Pressure:	1011 mbar

Note: N/A

#### Reference level measurement

TestMode	Antenna	Freq(MHz)	Max.Point[MHz]	Result[dBm]
FSK	Ant1	2405	2404.99	8.94
		2440	2440.00	8.82
		2475	2474.99	9.43

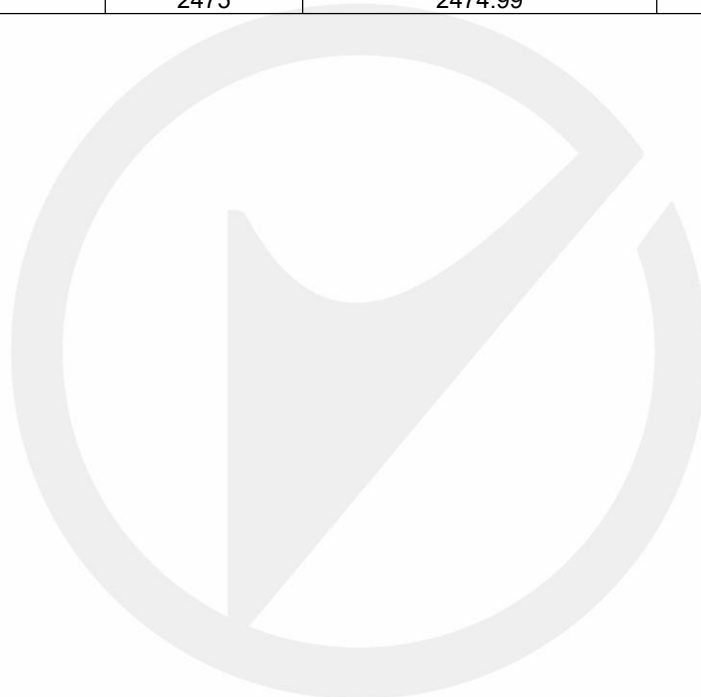

## FSK\_Ant1\_2405



## FSK\_Ant1\_2440



## FSK\_Ant1\_2475



**Band edge measurements**

TestMode	Antenna	ChName	Frequency[MHz]	RefLevel [dBm]	Result [dBm]	Limit [dBm]	Verdict
FSK	Ant1	Low	2405	8.94	-33.68	≤-11.06	PASS
		High	2475	9.43	-45.65	≤-10.57	PASS
		Low	Hop_2402	-8.82	-47.74	≤-28.82	PASS
		High	Hop_2480	-6.84	-43.2	≤-26.84	PASS



## FSK Ant1 Low 2405

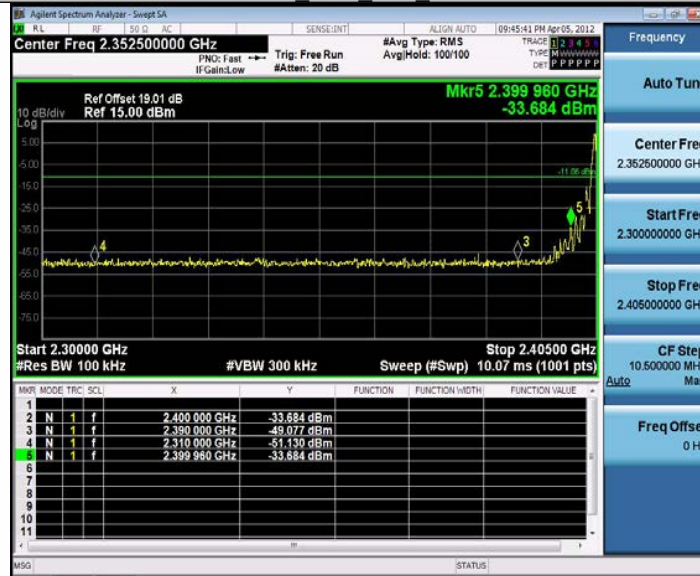

## FSK Ant1 High 2475



## FSK Ant1 Low Hop 2402

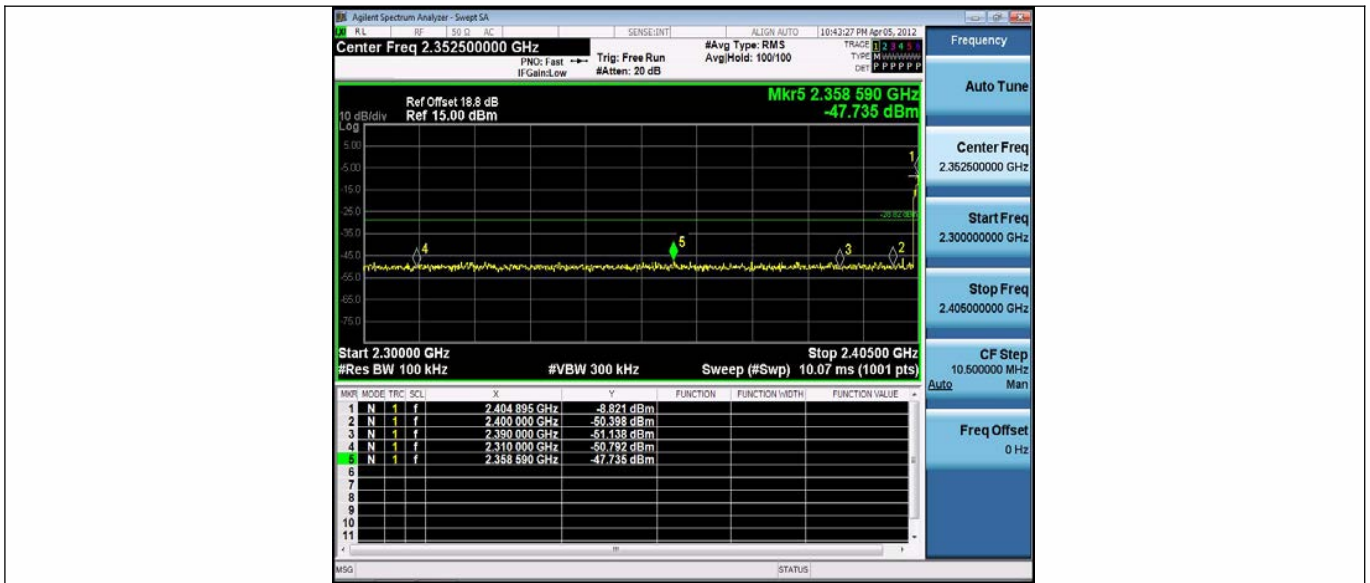

## FSK Ant1 High Hop 2480





### Conducted Spurious Emission

TestMode	Antenna	Frequency[MHz]	FreqRange [MHz]	RefLevel [dBm]	Result [dBm]	Limit [dBm]	Verdict
FSK	Ant1	2405	30~1000	8.94	-45.58	≤-11.06	PASS
			1000~26500	8.94	-46.23	≤-11.06	PASS
		2440	30~1000	8.82	-45.37	≤-11.18	PASS
			1000~26500	8.82	-47.86	≤-11.18	PASS
		2475	30~1000	9.43	-45.01	≤-10.57	PASS
			1000~26500	9.43	-48.1	≤-10.57	PASS





## FSK Ant1 2405 30~1000

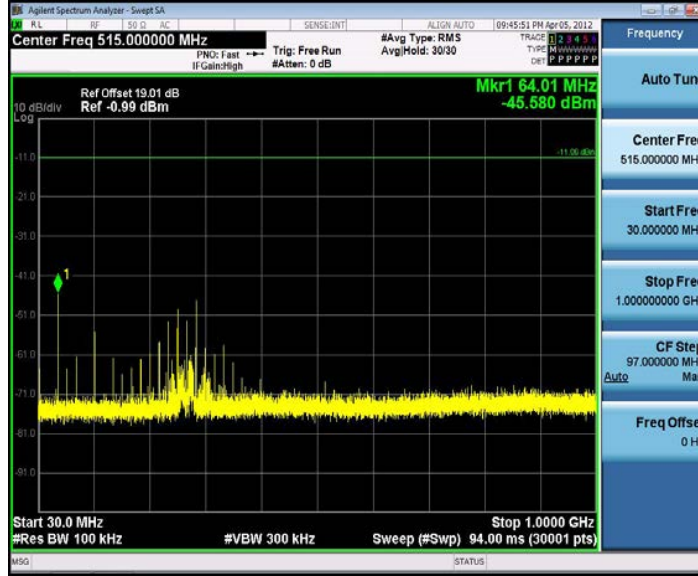

## FSK Ant1 2405 1000~26500



## FSK Ant1 2440 30~1000

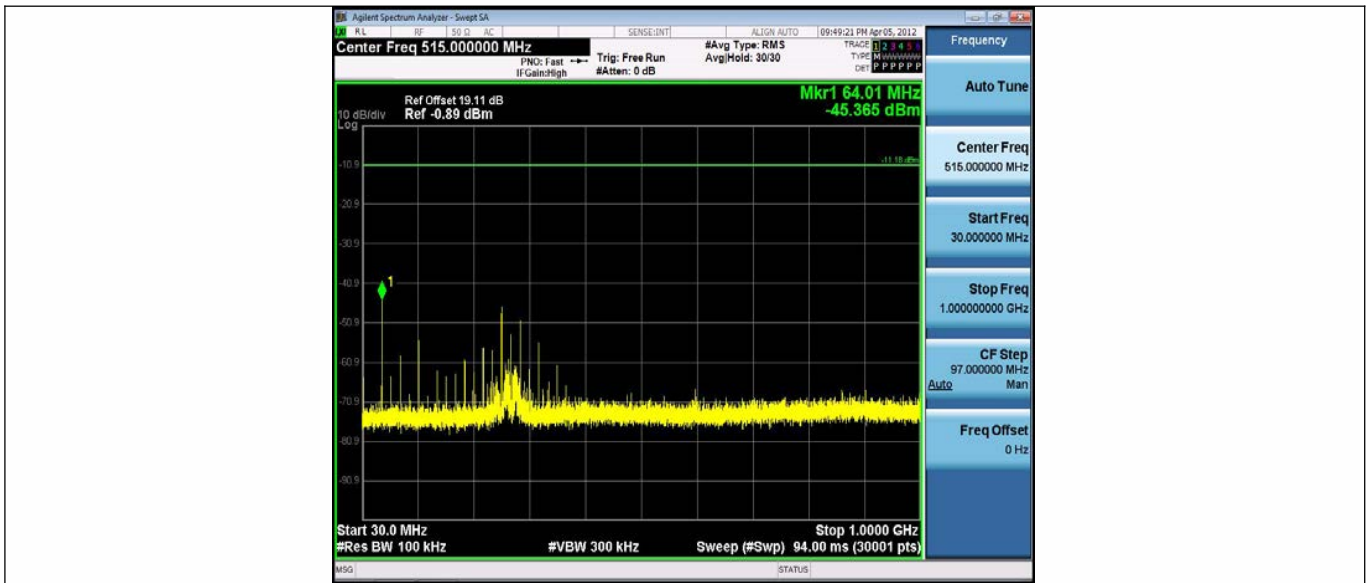

FSK\_Ant1\_2440\_1000~26500

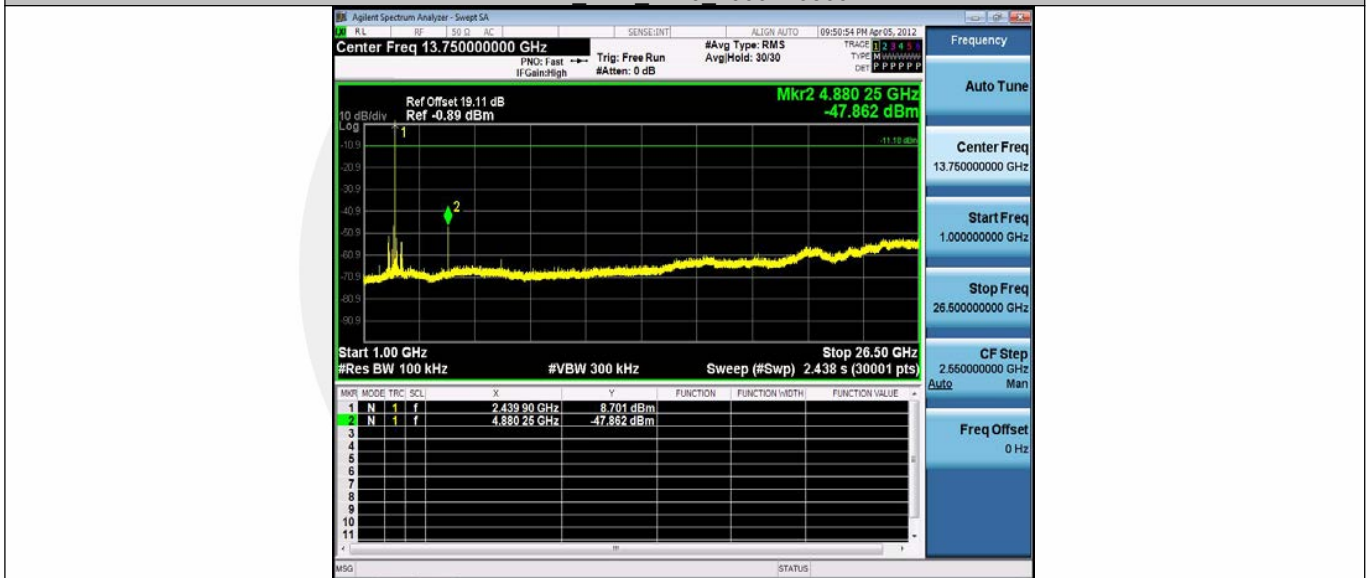

FSK\_Ant1\_2475\_30~1000

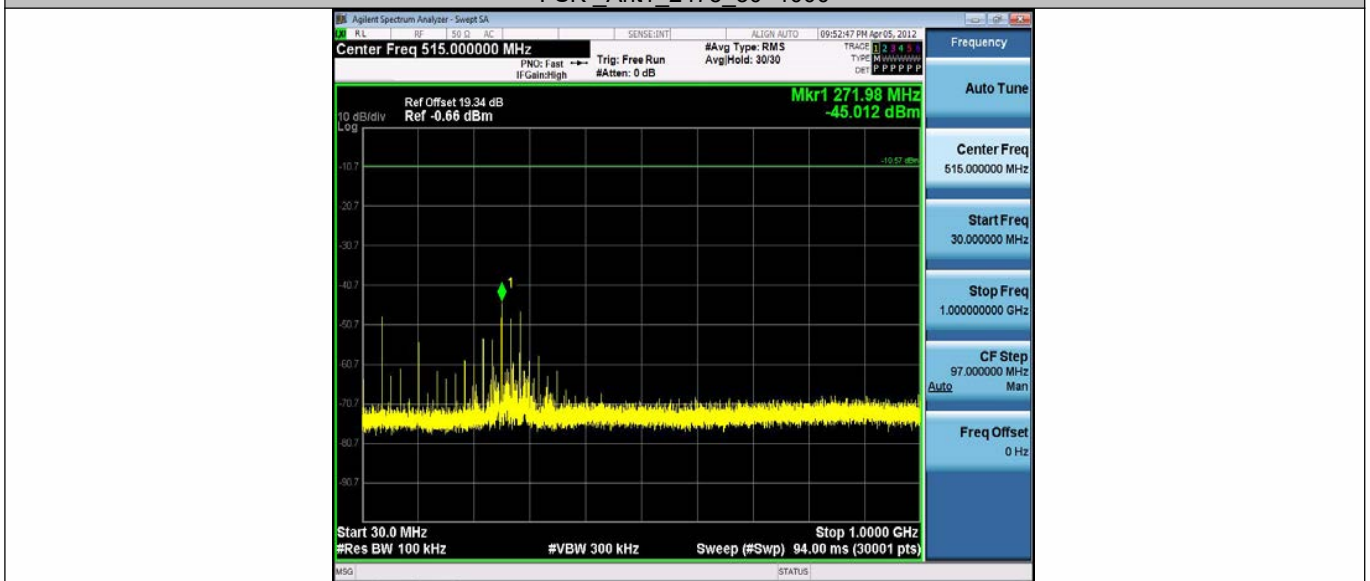



## 8.7 RADIATED SPURIOUS EMISSION

### 8.7.1 Applicable Standard

According to FCC Part 15.247(d), 15.205, 15.209 and KDB 558074 D01 15.247 MEAS GUIDANCE v05r02  
According to IC RSS-Gen and RSS-247

### 8.7.2 Conformance Limit

According to FCC Part 15.247(d): radiated emissions which fall in the restricted bands, as defined in §15.205(a), must also comply with the radiated emission limits specified in §15.209(a) (see §15.205(c)).

According to FCC Part 15.205, Restricted bands

MHz	MHz	MHz	GHz
0.090-0.110	16.42-16.423	399.9-410	4.5-5.15
10.495-0.505	16.69475-16.69525	608-614	5.35-5.46
2.1735-2.1905	16.80425-16.80475	960-1240	7.25-7.75
4.125-4.128	25.5-25.67	1300-1427	8.025-8.5
4.17725-4.17775	37.5-38.25	1435-1626.5	9.0-9.2
4.20725-4.20775	73-74.6	1645.5-1646.5	9.3-9.5
6.215-6.218	74.8-75.2	1660-1710	10.6-12.7
6.26775-6.26825	123-138	2200-2300	14.47-14.5
8.291-8.294	149.9-150.05	2310-2390	15.35-16.2
8.362-8.366	156.52475-156.52525	2483.5-2500	17.7-21.4
8.37625-8.38675	156.7-156.9	2690-2900	22.01-23.12
8.41425-8.41475	162.0125-167.17	3260-3267	23.6-24.0
12.29-12.293	167.72-173.2	3332-3339	31.2-31.8
12.51975-12.52025	240-285	3345.8-3358	36.43-36.5
12.57675-12.57725	322-335.4	3600-4400	(2)
13.36-13.41			

According to FCC Part 15.205, the level of any transmitter spurious emission in Restricted bands shall not exceed the level of the emission specified in the following table

Restricted Frequency(MHz)	Field Strength ( $\mu\text{V}/\text{m}$ )	Field Strength ( $\text{dB}\mu\text{V}/\text{m}$ )	Measurement Distance
0.009-0.490	2400/F(KHz)	20 log ( $\mu\text{V}/\text{m}$ )	300
0.490-1.705	24000/F(KHz)	20 log ( $\mu\text{V}/\text{m}$ )	30
1.705-30	30	29.5	30
30-88	100	40	3
88-216	150	43.5	3
216-960	200	46	3
Above 960	500	54	3

### 8.7.3 Test Configuration

Test according to clause 7.2 radio frequency test setup 2

### 8.7.4 Test Procedure

This test is required for any spurious emission that falls in a Restricted Band, as defined in Section 15.205. It must be performed with the highest gain of each type of antenna proposed for use with the EUT. Use the following spectrum analyzer settings:

For Above 1GHz:

The EUT was placed on a turn table which is 1.5m above ground plane.

Maximum procedure was performed on the highest emissions to ensure EUT compliance.

Span = wide enough to fully capture the emission being measured

RBW = 1 MHz

VBW  $\geq$  RBW

Sweep = auto

Detector function = peak

Trace = max hold

For Below 1GHz:

The EUT was placed on a turn table which is 0.8m above ground plane.

Maximum procedure was performed on the highest emissions to ensure EUT compliance.

Span = wide enough to fully capture the emission being measured

RBW = 100 kHz for

VBW ≥ RBW

Sweep = auto

Detector function = peak

Trace = max hold

For Below 30MHz:

The EUT was placed on a turn table which is 0.8m above ground plane.

Maximum procedure was performed on the highest emissions to ensure EUT compliance.

Span = wide enough to fully capture the emission being measured

RBW = 9kHz

VBW ≥ RBW

Sweep = auto

Detector function = peak

Trace = max hold

For Below 150KHz:

The EUT was placed on a turn table which is 0.8m above ground plane.

Maximum procedure was performed on the highest emissions to ensure EUT compliance.

Span = wide enough to fully capture the emission being measured

RBW = 200Hz

VBW ≥ RBW

Sweep = auto

Detector function = peak

Trace = max hold

Follow the guidelines in ANSI C63.10-2013 with respect to maximizing the emission by rotating the EUT, measuring the emission while the EUT is situated in three orthogonal planes (if appropriate), adjusting the measurement antenna height and polarization, etc. A pre-amp and a high pass filter are required for this test, in order to provide the measuring system with sufficient sensitivity. Allow the trace to stabilize. The peak reading of the emission, after being corrected by the antenna factor, cable loss, pre-amp gain, etc., is the peak field strength, which must comply with the limit specified in Section 15.35(b). Submit this data.

Now set the VBW to 10 Hz, while maintaining all of the other instrument settings. This peak level, once corrected, must comply with the limit specified in Section 15.209. If the dwell time per channel of the hopping signal is less than 100 ms, then the reading obtained with the 10 Hz VBW may be further adjusted by a “duty cycle correction factor”, derived from  $20\log(\text{dwell time}/100 \text{ ms})$ , in an effort to demonstrate compliance with the 15.209 limit. Submit this data.

Repeat above procedures until all frequency measured was complete.

### 8.7.5 Test Results

#### ■ Spurious Emission below 30MHz(9KHz to 30MHz)

Temperature:	25° C
Relative Humidity:	60%
ATM Pressure:	1011 mbar

Freq. (MHz)	Ant.Pol. H/V	Emission Level(dBuV/m)		Limit 3m(dBuV/m)		Over(dB)	
		PK	AV	PK	AV	PK	AV
--	--	--	--	--	--	--	--

Note: the amplitude of spurious emission that is attenuated by more than 20dB below the permissible limit has no need to be reported.

Distance extrapolation factor =  $40\log(\text{Specific distance}/ \text{test distance})$  (dB);

Limit line = Specific limits(dBuV) + distance extrapolation factor

#### ■ Spurious Emission Above 1GHz(1GHz to 25GHz)



Test mode: FSK Frequency: Channel 1: 2405MHz

Freq. (MHz)	Ant.Pol.	Emission Level(dBuV/m)		Limit 3m(dBuV/m)		Over(dB)	
	H/V	PK	AV	PK	AV	PK	AV
4807.5	V	57.96	35.71	74.00	54.00	16.04	18.29
11518.12	V	60.84	38.71	74.00	54.00	13.16	15.29
17649.37	V	66.14	44.78	74.00	54.00	7.86	9.22
4809.375	H	55.36	35.33	74.00	54.00	18.64	18.67
11521.87	H	60.45	38.53	74.00	54.00	13.55	15.47
17600.62	H	67.23	46.75	74.00	54.00	6.77	7.25

Test mode: FSK Frequency: Channel 8: 2440MHz

Freq. (MHz)	Ant.Pol.	Emission Level(dBuV/m)		Limit 3m(dBuV/m)		Over(dB)	
	H/V	PK	AV	PK	AV	PK	AV
4890	V	54.91	35.11	74.00	54.00	19.09	18.89
11486.25	V	61.56	38.89	74.00	54.00	12.44	15.11
17638.12	V	67.49	45.46	74.00	54.00	6.51	8.54
4890	H	54.52	34.62	74.00	54.00	19.48	19.38
11493.75	H	60.90	40.06	74.00	54.00	13.10	13.94
17032.5	H	66.15	44.13	74.00	54.00	7.85	9.87

Test mode: FSK Frequency: Channel 15: 2475MHz

Freq. (MHz)	Ant.Pol.	Emission Level(dBuV/m)		Limit 3m(dBuV/m)		Over(dB)	
	H/V	PK	AV	PK	AV	PK	AV
4950	V	55.09	33.67	74.00	54.00	18.91	20.33
11497.5	V	60.47	39.05	74.00	54.00	13.53	14.95
17640	V	65.92	44.70	74.00	54.00	8.08	9.30
4948.125	H	52.98	34.96	74.00	54.00	21.02	19.04
11503.12	H	60.81	39.03	74.00	54.00	13.19	14.97
17593.12	H	67.40	46.07	74.00	54.00	6.60	7.93

- Note:**
- (1) All Readings are Peak Value (VBW=3MHz) and Average Value (VBW=10Hz).
  - (2) Emission Level= Reading Level+Correct Factor.
  - (3) Correct Factor= Ant\_F + Cab\_L - Preamp
  - (4) The reading of emissions are attenuated more than 20dB below the permissible limits or the field strength is too small to be measured.

## ■ Spurious Emission in Restricted Band 2310-2390MHz and 2483.5-2500MHz

Test mode: FSK Frequency: Channel 1: 2405MHz

Frequency (MHz)	Polarity H/V	PK(dBuV/m) (VBW=3MHz)	Limit 3m (dBuV/m)	AV(dBuV/m) (VBW=10Hz)	Limit 3m (dBuV/m)
2382.29	H	45.58	74.00	37.15	54.00
2389.94	V	45.66	74.00	37.06	54.00

Test mode: FSK Frequency: Channel 15: 2475MHz

Frequency (MHz)	Polarity H/V	PK(dBuV/m) (VBW=3MHz)	Limit 3m (dBuV/m)	AV(dBuV/m) (VBW=10Hz)	Limit 3m (dBuV/m)
2483.86	H	51.56	74.00	37.43	54.00
2483.66	V	49.12	74.00	37.32	54.00

Test mode: FSK Frequency: Hopping

Frequency (MHz)	Polarity H/V	PK(dBuV/m) (VBW=3MHz)	Limit 3m (dBuV/m)	AV(dBuV/m) (VBW=10Hz)	Limit 3m (dBuV/m)
2389.193	H	44.08	74.00	37.13	54.00
2484.541	H	45.66	74.00	37.54	54.00
2389.129	V	44.25	74.00	37.13	54.00
2483.527	V	46.22	74.00	37.32	54.00

- Note:**
- (1) All Readings are Peak Value (VBW=3MHz) and Average Value (VBW=10Hz).
  - (2) Emission Level= Reading Level+Correct Factor.
  - (3) Correct Factor= Ant\_F + Cab\_L - Preamp
  - (4) The reading of emissions are attenuated more than 20dB below the permissible limits or the field strength is too small to be measured.

**Test Model**      **Spurious Emission in Restricted Band 2310-2390MHz**  
**Channel 1: 2405MHz**      **FSK**      **V**

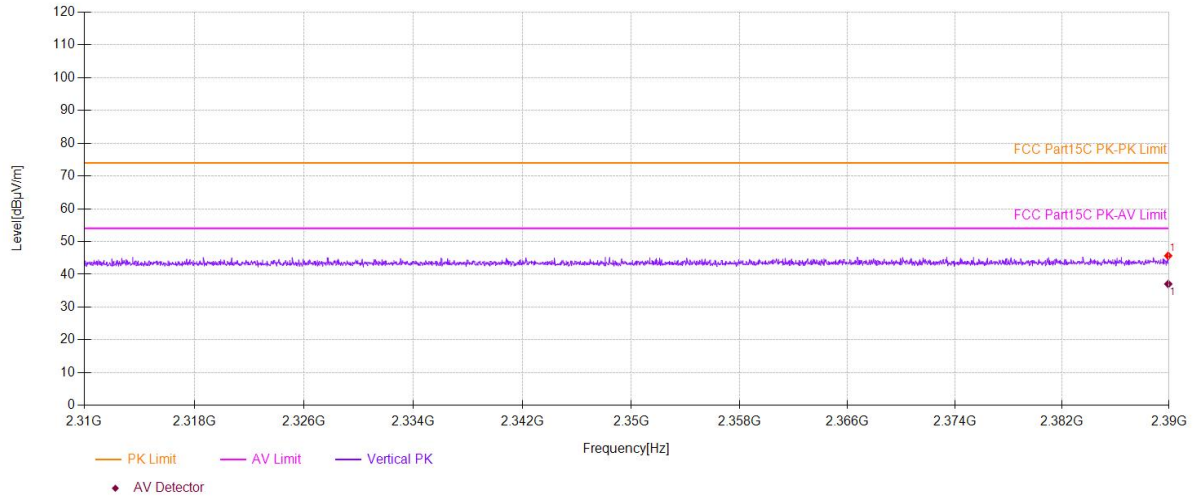

**Test Model**      **Spurious Emission in Restricted Band 2310-2390MHz**  
**Channel 1: 2405MHz**      **FSK**      **H**

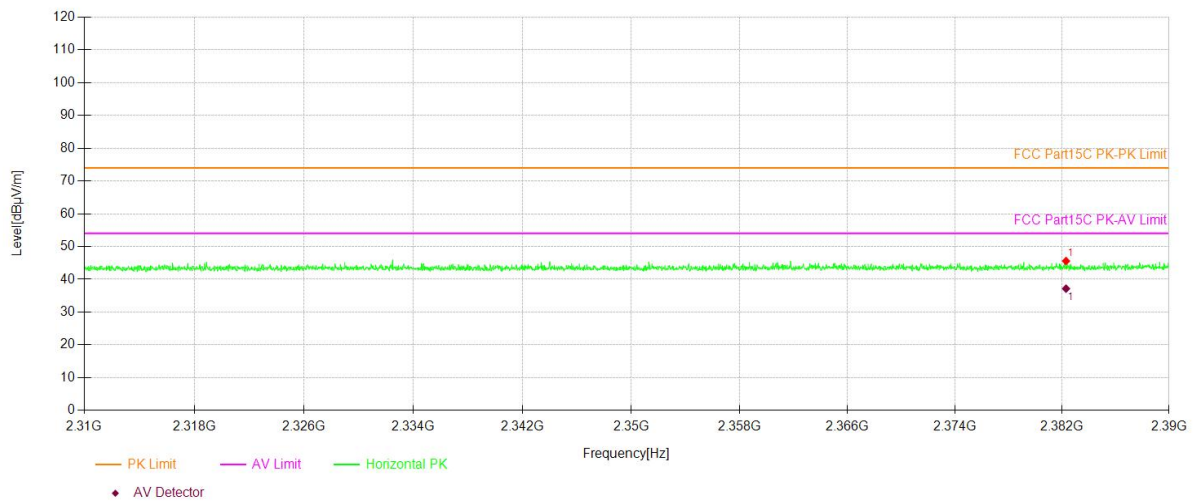



**Test Model**      **Spurious Emission in Restricted Band 2483.5-2500MHz**  
**Channel 15: 2475MHz**      **FSK**      **V**

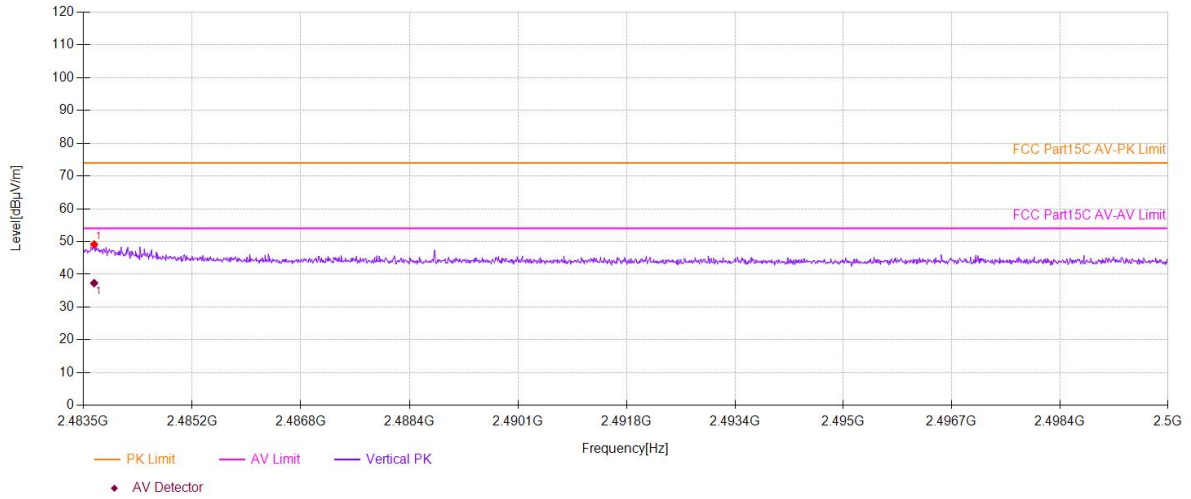

**Test Model**      **Spurious Emission in Restricted Band 2483.5-2500MHz**  
**Channel 15: 2475MHz**      **FSK**      **H**

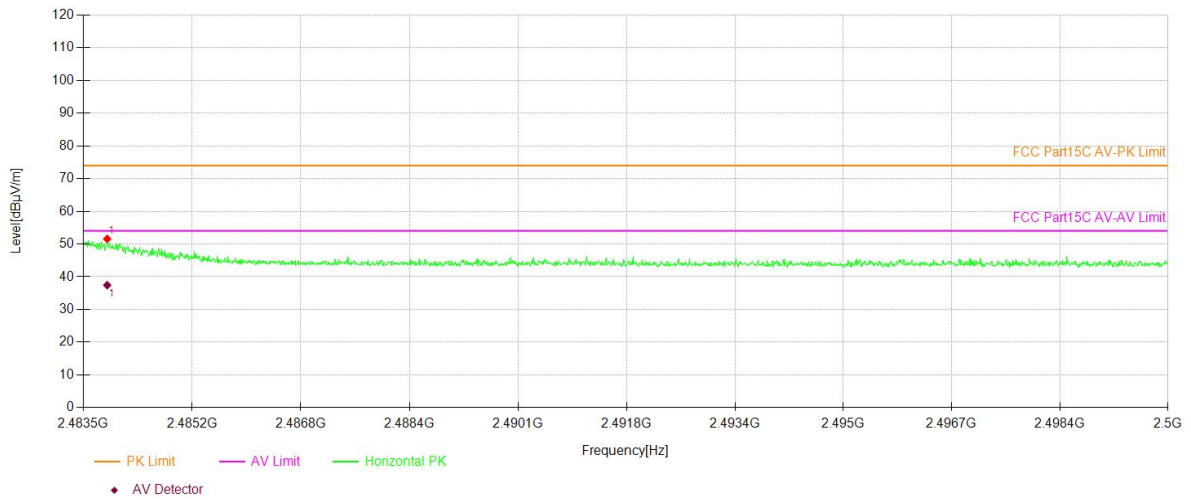

**Test Model** Spurious Emission in Restricted Band 2310-2390MHz and 2400-2483.5MHz Hopping FSK V

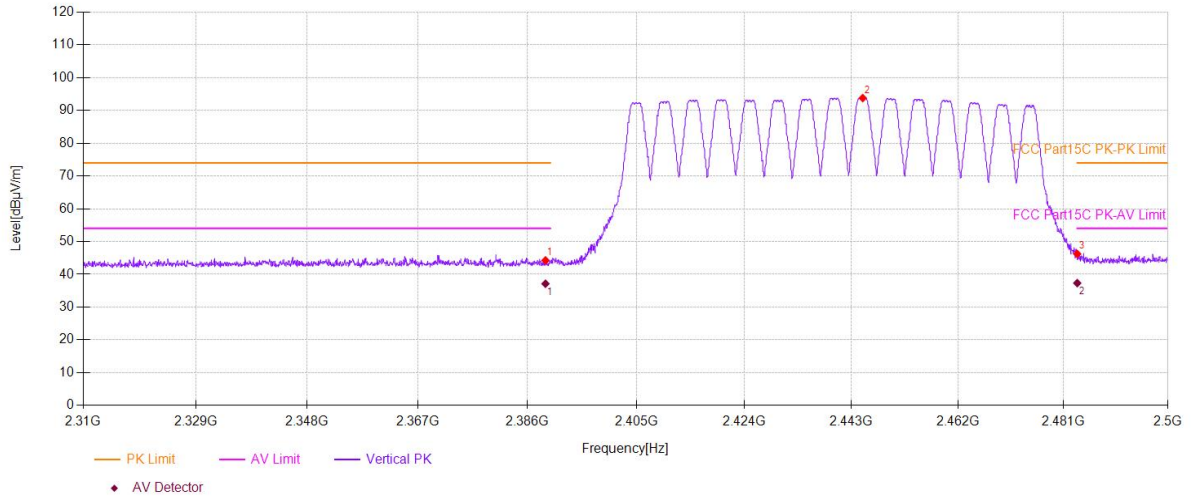

**Test Model** Spurious Emission in Restricted Band 2310-2390MHz and 2400-2483.5MHz Hopping FSK H

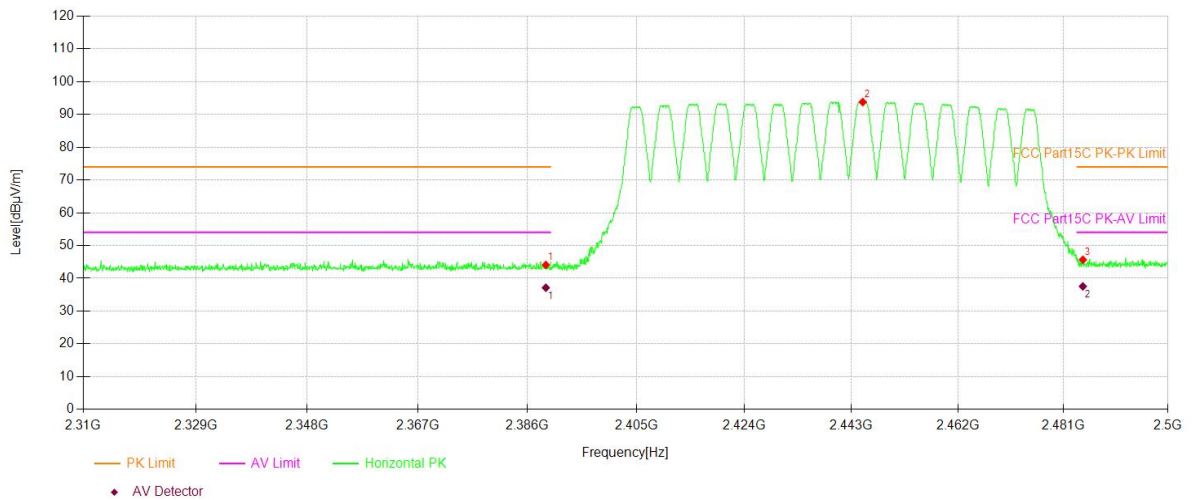

■ Spurious Emission below 1GHz(30MHz to 1GHz)

Mode:	FSK 2405
Environment:	Temp: 25°C; Humi:60%

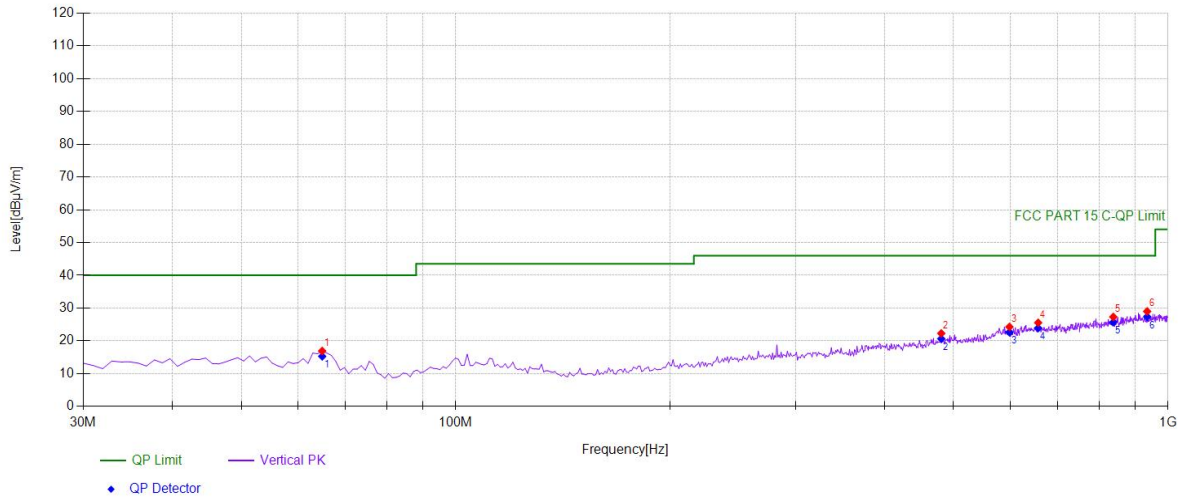

Suspected Data List								
NO.	Freq. [MHz]	Reading [dBμV]	Factor [dB/m]	Level [dBμV/m]	Detector	Limit [dBμV/m]	Margin [dB]	Polarity
1	64.955	36.18	-19.25	16.93	PK	40.00	23.07	Vertical
2	480.5305	32.08	-9.78	22.30	PK	46.00	23.70	Vertical
3	598.989	31.42	-7.14	24.28	PK	46.00	21.72	Vertical
4	657.2472	31.70	-6.15	25.55	PK	46.00	20.45	Vertical
5	837.8478	31.23	-3.91	27.32	PK	46.00	18.68	Vertical
6	934.9449	31.54	-2.54	29.00	PK	46.00	17.00	Vertical

Mode:	FSK 2405
Environment:	Temp: 25°C; Humi:60%

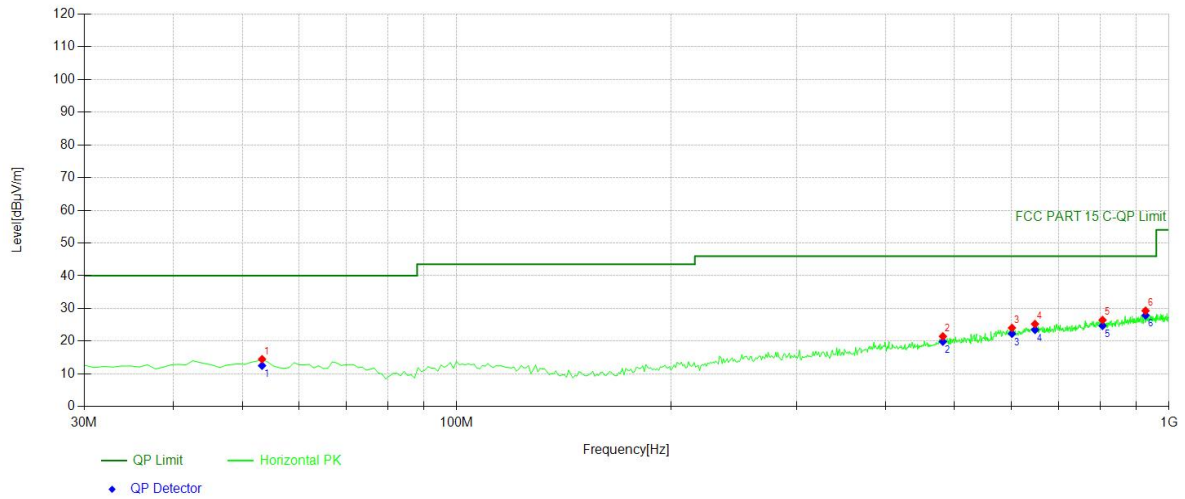

Suspected Data List								
NO.	Freq. [MHz]	Reading [dBµV]	Factor [dB/m]	Level [dBµV/m]	Detector	Limit [dBµV/m]	Margin [dB]	Polarity
1	53.3033	32.15	-17.65	14.50	PK	40.00	25.50	Horizontal
2	481.5015	31.26	-9.78	21.48	PK	46.00	24.52	Horizontal
3	601.9019	31.20	-7.13	24.07	PK	46.00	21.93	Horizontal
4	648.5085	31.47	-6.22	25.25	PK	46.00	20.75	Horizontal
5	806.7768	30.84	-4.37	26.47	PK	46.00	19.53	Horizontal
6	927.1772	32.00	-2.69	29.31	PK	46.00	16.69	Horizontal

Mode:	FSK 2440
Environment:	Temp: 25°C; Humi:60%

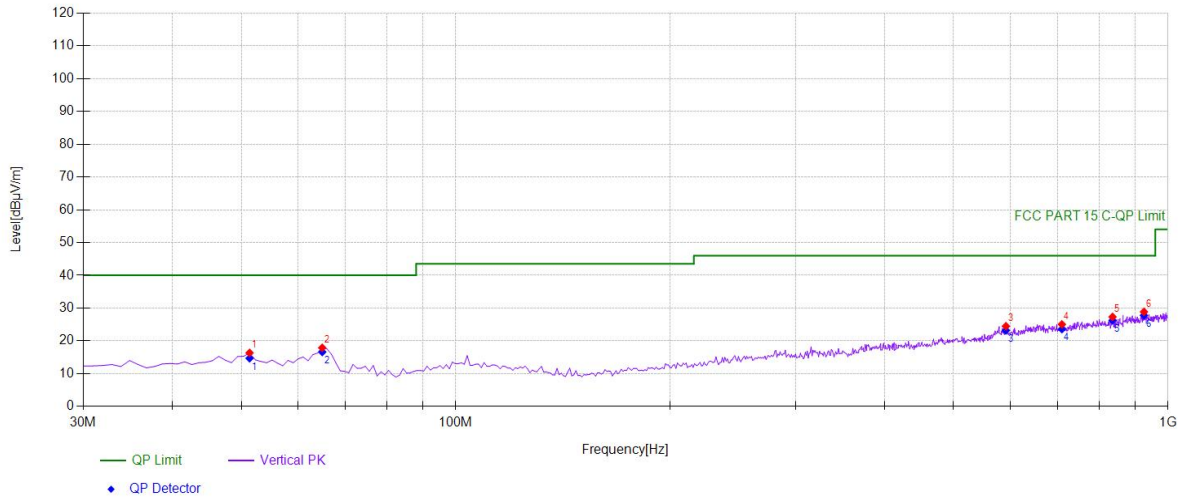

Suspected Data List								
NO.	Freq. [MHz]	Reading [dBµV]	Factor [dB/m]	Level [dBµV/m]	Detector	Limit [dBµV/m]	Margin [dB]	Polarity
1	51.3614	33.74	-17.39	16.35	PK	40.00	23.65	Vertical
2	64.955	37.16	-19.25	17.91	PK	40.00	22.09	Vertical
3	592.1922	31.62	-7.14	24.48	PK	46.00	21.52	Vertical
4	709.6797	30.89	-5.84	25.05	PK	46.00	20.95	Vertical
5	835.9059	31.29	-3.96	27.33	PK	46.00	18.67	Vertical
6	925.2352	31.60	-2.73	28.87	PK	46.00	17.13	Vertical

Mode:	FSK 2440
Environment:	Temp: 25°C; Humi:60%

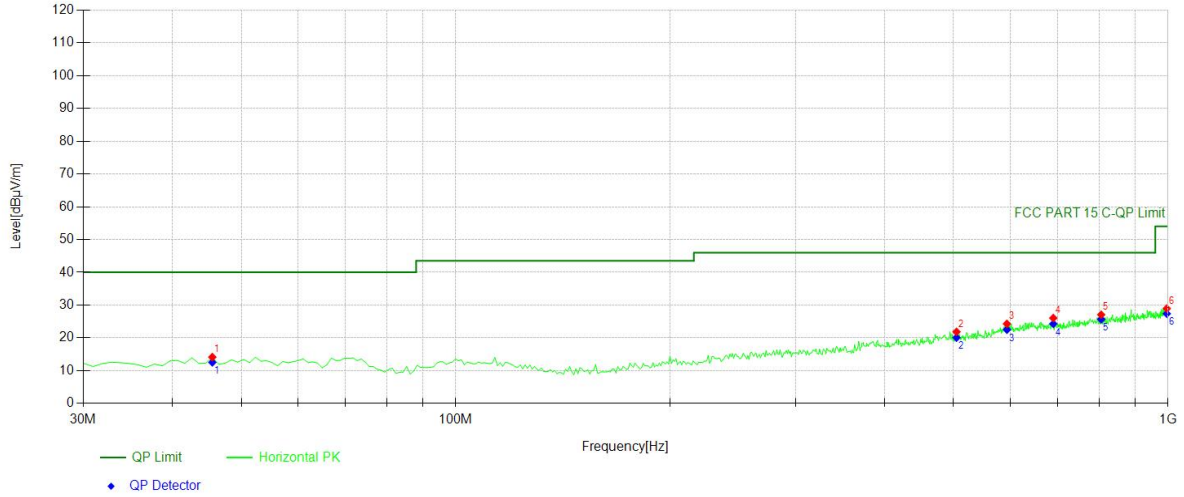

Suspected Data List								
NO.	Freq. [MHz]	Reading [dBµV]	Factor [dB/m]	Level [dBµV/m]	Detector	Limit [dBµV/m]	Margin [dB]	Polarity
1	45.5355	31.68	-17.53	14.15	PK	40.00	25.85	Horizontal
2	504.8048	31.62	-9.77	21.85	PK	46.00	24.15	Horizontal
3	594.1341	31.43	-7.14	24.29	PK	46.00	21.71	Horizontal
4	690.2603	32.09	-6.03	26.06	PK	46.00	19.94	Horizontal
5	805.8058	31.44	-4.37	27.07	PK	46.00	18.93	Horizontal
6	996.1161	30.67	-1.71	28.96	PK	54.00	25.04	Horizontal

Mode:	FSK 2475
Environment:	Temp: 25°C; Humi:60%

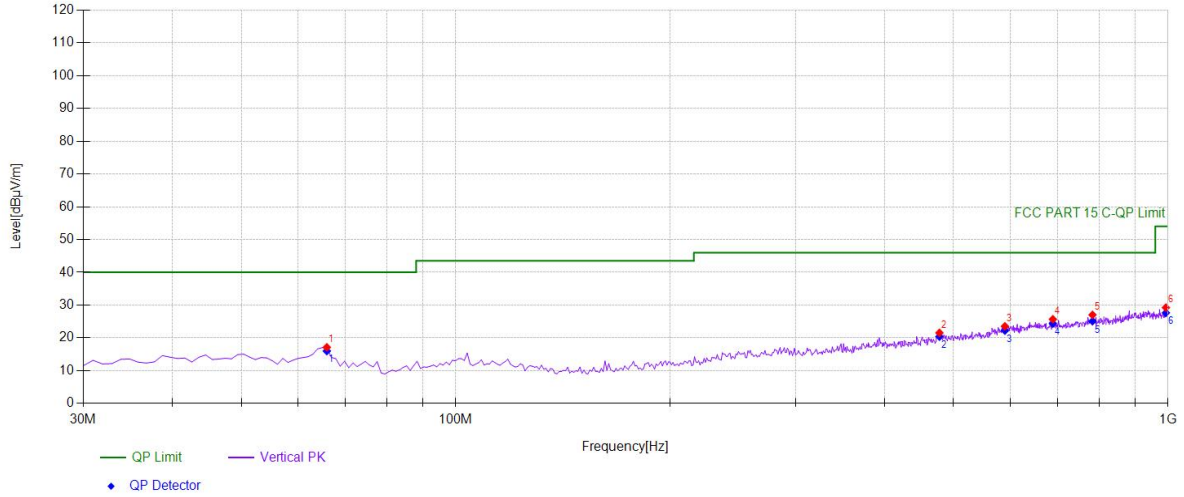

Suspected Data List								
NO.	Freq. [MHz]	Reading [dBµV]	Factor [dB/m]	Level [dBµV/m]	Detector	Limit [dBµV/m]	Margin [dB]	Polarity
1	65.9259	36.52	-19.39	17.13	PK	40.00	22.87	Vertical
2	477.6176	31.47	-9.93	21.54	PK	46.00	24.46	Vertical
3	590.2503	30.67	-7.14	23.53	PK	46.00	22.47	Vertical
4	689.2893	31.72	-6.03	25.69	PK	46.00	20.31	Vertical
5	783.4735	31.62	-4.59	27.03	PK	46.00	18.97	Vertical
6	993.2032	30.95	-1.71	29.24	PK	54.00	24.76	Vertical



Mode:	FSK 2475
Environment:	Temp: 25°C; Humi:60%

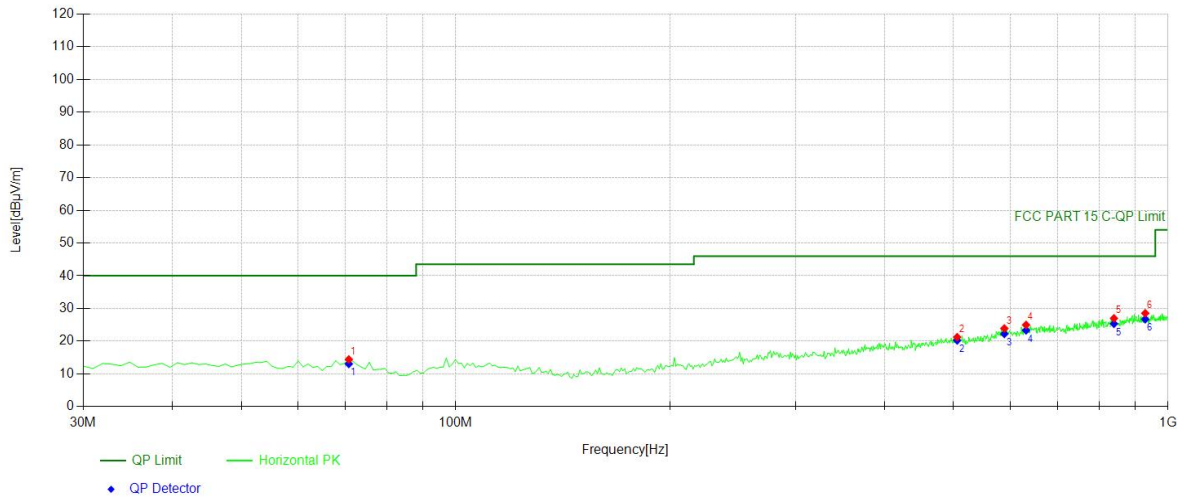

Suspected Data List								
NO.	Freq. [MHz]	Reading [dBµV]	Factor [dB/m]	Level [dBµV/m]	Detector	Limit [dBµV/m]	Margin [dB]	Polarity
1	70.7808	34.51	-20.08	14.43	PK	40.00	25.57	Horizontal
2	505.7758	31.03	-9.77	21.26	PK	46.00	24.74	Horizontal
3	589.2793	31.04	-7.14	23.90	PK	46.00	22.10	Horizontal
4	632.002	31.61	-6.63	24.98	PK	46.00	21.02	Horizontal
5	839.7898	30.85	-3.86	26.99	PK	46.00	19.01	Horizontal
6	929.1191	31.18	-2.64	28.54	PK	46.00	17.46	Horizontal



## 8.8 CONDUCTED EMISSION TEST

### 8.8.1 Applicable Standard

According to FCC Part 15.207

According to IC RSS-Gen 8.8

### 8.8.2 Conformance Limit

Conducted Emission Limit		
Frequency(MHz)	Quasi-peak	Average
0.15-0.5	66-56	56-46
0.5-5.0	56	46
5.0-30.0	60	50

Note: 1. The lower limit shall apply at the transition frequencies  
2. The limit decreases in line with the logarithm of the frequency in the range of 0.15 to 0.50MHz.

### 8.8.3 Test Configuration

Test according to clause 7.3 conducted emission test setup

### 8.8.4 Test Procedure

The EUT was placed on a table which is 0.8m above ground plane.  
Maximum procedure was performed on the highest emissions to ensure EUT compliance.  
Repeat above procedures until all frequency measured were complete.

### 8.8.5 Test Results

Pass

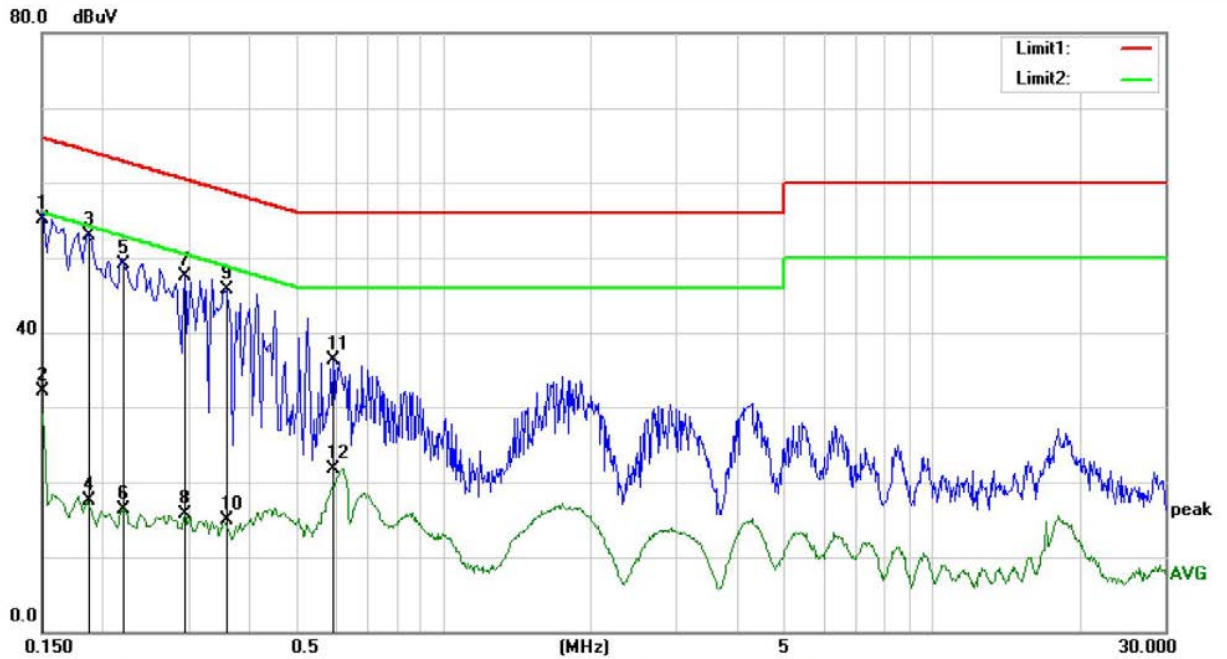

Site Conduction #1

Phase: **L1**

Temperature: 20.8

Limit: (CE)FCC PART 15 class B\_QP

Power: DC 5V FROM ADAPTER

Humidity: 61 %

Mode: ON

Note:

No.	Mk.	Freq. MHz	Reading Level dBuV	Correct Factor dB	Measure- ment dBuV	Limit dBuV	Over dB	Detector	Comment
1	*	0.1500	45.59	9.51	55.10	66.00	-10.90	QP	
2		0.1500	22.57	9.51	32.08	56.00	-23.92	AVG	
3		0.1874	43.05	9.95	53.00	64.15	-11.15	QP	
4		0.1874	7.51	9.95	17.46	54.15	-36.69	AVG	
5		0.2220	39.05	10.08	49.13	62.74	-13.61	QP	
6		0.2220	6.31	10.08	16.39	52.74	-36.35	AVG	
7		0.2940	37.57	10.03	47.60	60.41	-12.81	QP	
8		0.2940	5.74	10.03	15.77	50.41	-34.64	AVG	
9		0.3580	35.71	9.91	45.62	58.77	-13.15	QP	
10		0.3580	4.98	9.91	14.89	48.77	-33.88	AVG	
11		0.5940	26.62	9.66	36.28	56.00	-19.72	QP	
12		0.5940	12.13	9.66	21.79	46.00	-24.21	AVG	

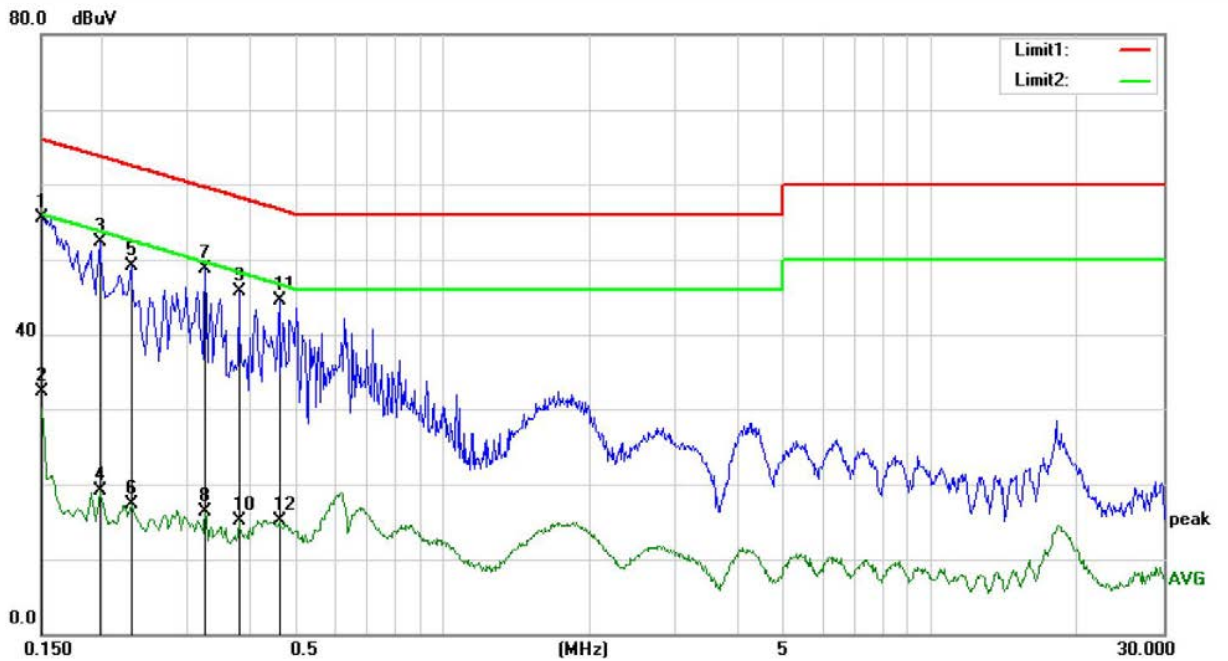

Site Conduction #1

Phase: **N**

Temperature: 20.8

Limit: (CE)FCC PART 15 class B\_QP

Power: DC 5V FROM ADAPTER

Humidity: 61 %

Mode: ON

Note:

No.	Mk.	Freq. MHz	Reading Level dBuV	Correct Factor dB	Measure- ment dBuV	Limit dBuV	Over dB	Detector	Comment
1	*	0.1508	45.89	9.52	55.41	65.96	-10.55	QP	
2		0.1508	22.86	9.52	32.38	55.96	-23.58	AVG	
3		0.1980	42.20	10.08	52.28	63.69	-11.41	QP	
4		0.1980	8.94	10.08	19.02	53.69	-34.67	AVG	
5		0.2300	38.93	10.08	49.01	62.45	-13.44	QP	
6		0.2300	7.15	10.08	17.23	52.45	-35.22	AVG	
7		0.3260	38.78	9.98	48.76	59.55	-10.79	QP	
8		0.3260	6.30	9.98	16.28	49.55	-33.27	AVG	
9		0.3820	35.75	9.86	45.61	58.24	-12.63	QP	
10		0.3820	5.15	9.86	15.01	48.24	-33.23	AVG	
11		0.4620	34.68	9.73	44.41	56.66	-12.25	QP	
12		0.4620	5.43	9.73	15.16	46.66	-31.50	AVG	

## 8.9 ANTENNA APPLICATION

### 8.9.1 Antenna Requirement

Standard	Requirement
FCC CRF Part15.203	An intentional radiator shall be designed to ensure that no antenna other than that furnished by the responsible party shall be used with the device. The use of a permanently attached antenna or of an antenna that uses a unique coupling to the intentional radiator shall be considered sufficient to comply with the provisions of this section. The manufacturer may design the unit so that a broken antenna can be replaced by the user, but the use of a standard antenna jack or electrical connector is prohibited.
FCC 47 CFR Part 15.247 (b)	If transmitting antennas of directional gain greater than 6dBi are used, the power shall be reduced by the amount in dB that the directional gain of the antenna exceeds 6dBi.
RSS-Gen Section 6.8	The applicant for equipment certification shall provide a list of all antenna types that may be used with the transmitter, where applicable (i.e. for transmitters with detachable antenna), indicating the maximum permissible antenna gain (in dBi) and the required impedance for each antenna. The test report shall demonstrate the compliance of the transmitter with the limit for maximum equivalent isotropically radiated power (e.i.r.p.) specified in the applicable RSS, when the transmitter is equipped with any antenna type, selected from this list.
RSS-247 Section 5.4	If the transmitter employs an antenna system that emits multiple directional beams, but does not emit multiple directional beams simultaneously, the total output power conducted to the array or arrays that comprise the device (i.e. the sum of the power supplied to all antennas, antenna elements, staves, etc., and summed across all carriers or frequency channels) shall not exceed the applicable output power limit. However, the total conducted output power shall be reduced by 1 dB below the specified limits for each 3 dB that the directional gain of the antenna/antenna array exceeds 6 dBi. The directional antenna gain shall be computed as the sum of 10 log (number of array elements or staves) plus the directional gain of the element or stave having the highest gain.

### 8.9.2 Result

PASS.

- Note:
- Antenna use a permanently attached antenna which is not replaceable.
  - Not using a standard antenna jack or electrical connector for antenna replacement
  - The antenna has to be professionally installed (please provide method of installation)

Please refer to the attached documentInternal Photos to show the antenna connector.

\*\*\* End of Report \*\*\*