

承 认 书

SPECIFICATION FOR APPROVAL

客 户
CUSTOMER: AN HAO XIN

客 户 料 号:
CUST P/N:

天 夏 料 号:
TX P/N: RX-AHX-Y162240TS-10uh (DLT-SWS001)

产 品 型 号
DESC: 17.5*21.5-0.23G-14TS-30mm-16*22*0.4CC

日 期
DATE: 2022/09/24

版 本:
Version: A.0

拟制 PREPARED BY	审核 CHECKED BY	批准 APPROVED BY	客户承认 CUSTOMER APPROVE
zeng wei hao	zhang yan	luoyongjun	

SHENZHEN TIANXIA TECHNOLOGY CO., LTD

Address: C33 Science and Innovation Park Baoan SHENZHEN

TEL: 18718699959

E-mail: 2321113770@qq.com

SPECIFICATION

产品型号: DESC	17.5*21.5-0.23G-14TS-30mm-16*22*0.4CC	Rev: A.0	客户CUST: 客户料号 CUST P/N:	AHX-DLT-SWS001
---------------	---------------------------------------	----------	---------------------------	----------------

一、尺寸 DIMENSION:(mm)

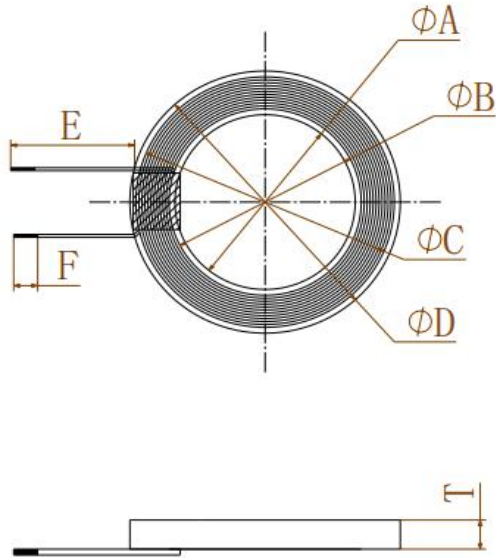

A	16±0.5
B	17.5±0.5
C	21.5±0.5
D	22±0.5
E	30mm±2
F	1mm-2mm
T	2mm MAX

Attention:

1. Cross out coil
2. Disk size 16*22*0.4mm
3. Thickness 2mmMAX;
4. Soak two of them in tin first;

二、原理图 SCHEMATIC DIAGRAM

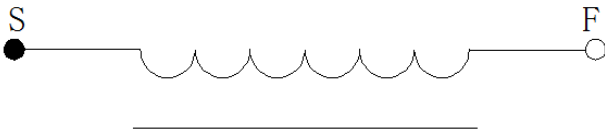

三、绕线参数 Winding Specification:

序号 NO.	端子 TERMINAL		线径 WIRE	圈数 Turns	绕线方向 Winding Direction
1	S	F	0.23*1P	14Ts	CR

四、电气特性 ELECTRICAL CHARACTERISTICS:

温度 TEMPERATURE:25±10°C, 湿度 RELATIVE HUMIDITY:65±20%

序号 NO.	项目 ITEM	端子 TERMINAL	标准 SPECIFICATION	测试条件 TEST FREQUENCY	测试仪器 TEST EQUIPMENTS
1	IND.	S-F	7.3 uH±10% 单独线圈	100KHz/1.0V	LCZ METER 1062B
2	IND.	S-F	10 uH±10% 带磁片	100KHz/1.0V	LCZ METER 1062B
3	DCR	S-F	600mΩ Max		LCZ METER 502B

拟制/日期 PREPARED BY/DATE

审核/日期 CHECKED BY/DATE

zeng wei hao 2022/09/24

zhang yan 2022/09/24