

SPECIFICATON APPROVAL  
(Wireless charging category)  
SPECIFICATION FOR APPROVAL

客户名称 **HAWORTH, INC.**  
*Customer Name:*

产品名称 **A11 Transmitting Magnetic Coil**  
*Product Name:*

项目编号 **X001**  
*Project Number:*

送样日期 **2021/2/20**  
*Delivery Date:*

|                         |         |         |         |         |
|-------------------------|---------|---------|---------|---------|
| 样板承认书编号: A1120211230-01 |         |         |         |         |
| sign                    |         |         |         |         |
| project                 | quality | market  | review  | approve |
|                         |         |         |         |         |
| customer signature      |         |         |         |         |
| purchase                | R&D     | quality | project | approve |
|                         | 蒋林城     |         |         | 王超群     |



|                       |                    |                      |             |
|-----------------------|--------------------|----------------------|-------------|
| Specification<br>规格内容 | 20.5*43*50*1.0*10T | CUSTOMER/N:<br>客户品名  | A11 Coil    |
|                       |                    | PARTNUMBER:<br>制造商料号 | WMRTA11-10T |

1.DIMENSIONS(外形尺寸) :

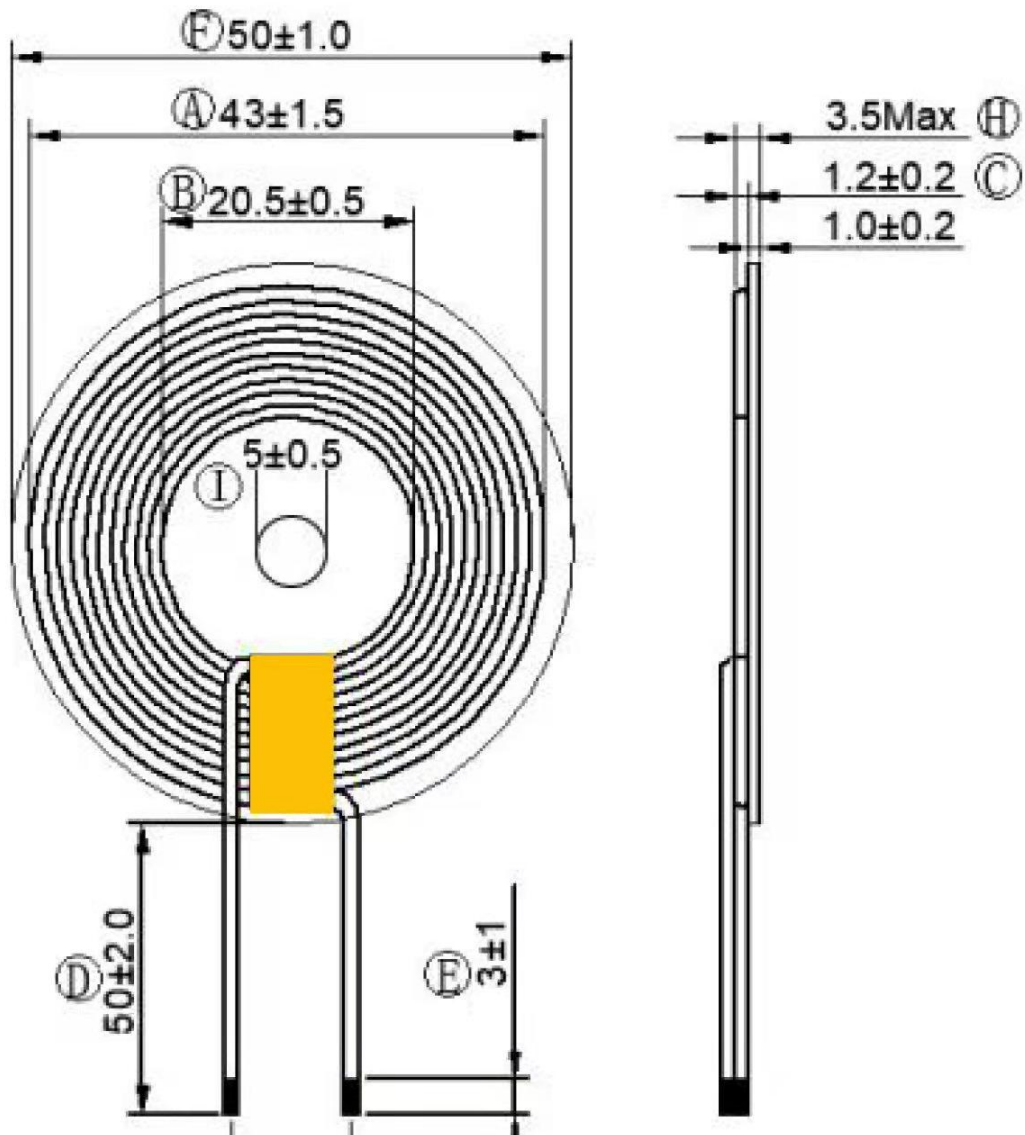

Note:

1. The overall appearance is clean and tidy, and the details are subject to the signed sample
2. Appearance Visually, the surface is smooth and flat, no flash, no burr, no sink mark, no weld marks, particles and scratches, and the appearance is poor

| APPROVED BY<br>承认 | CHECKED BY<br>审查 | PREPARED BY<br>制作 | DATE<br>日期 | PAGE<br>页码 |
|-------------------|------------------|-------------------|------------|------------|
|                   |                  |                   | 2021/12/30 | 2 of 4     |

|                       |                    |                      |             |
|-----------------------|--------------------|----------------------|-------------|
| Specification<br>规格内容 | 20.5*43*50*1.0*10T | CUSTOMER/N:<br>客户品名  | A11 Coil    |
|                       |                    | PARTNUMBER:<br>制造商料号 | WMRTA11-10T |

**5.WINDING DETAILS(绕线详细说明) :**

| Wdy.NO.<br>绕组 | Start<br>开始 | Finish<br>结束 | Turns<br>圈数 | Wire Dia<br>线径                       | Wdg.TypeSprad/lose<br>绕线方法疏/密绕 | Wdg.Direction<br>绕线方向  | Turns/Layer<br>层数/每层圈数 |
|---------------|-------------|--------------|-------------|--------------------------------------|--------------------------------|------------------------|------------------------|
| 1             | S           | F            | 10TS        | Multi-strand<br>wire covered<br>wire | tightly<br>wound               | counter /<br>clockwise | 1层/10TS                |

公差±0.5TS

**6.ELECTRICAL CHARACTERISTICS(电气特性) :**

| PARAMETERS                               | UNIN | LIMITI      |
|--|------|-------------|
| Inductance $I_s@100\text{KHz}/1\text{v}$ | uh   | 6.3uH ± 10% |
| DCR @100KHz/1v                           | Ω    | 65m Ω MAX   |

未注明参数公差±5%

备注:

| APPROVED BY<br>承认 | CHECKED BY<br>审查 | PREPARED BY<br>制作 | DATE<br>日期 | PAGE<br>页码 |
|-------------------|------------------|-------------------|------------|------------|
|                   |                  |                   | 2021/12/30 | 3 of 4     |