

WH05+S6A说明书

WH05-S6A

Owner Manual

With Suction Cup
Wireless Car Charger

YOUR BEST DRIVE PARTNER

INSTALLATION GUIDE

Step 1

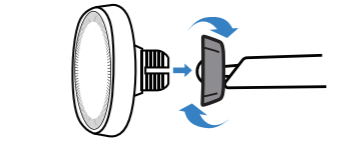

Step 2

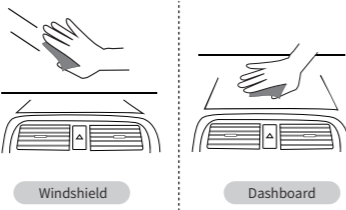

Windshield Dashboard

Step 3

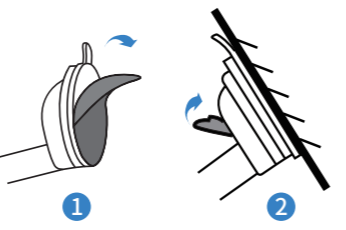

Step 4

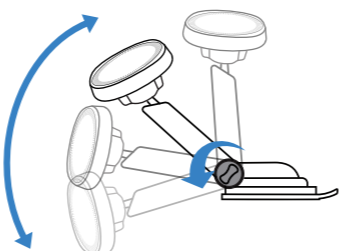

Step 5

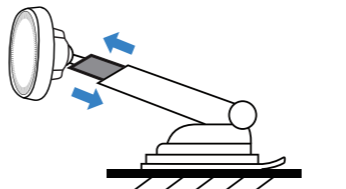

Step 6

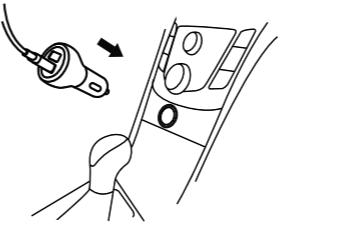

Step 6

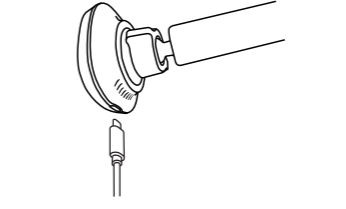

Step 6

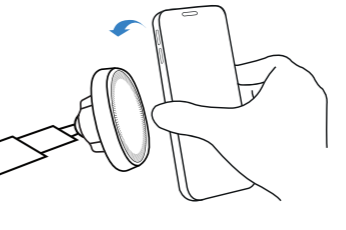

ATTENTION

Tips 1

Suction Cup Removal Instructions

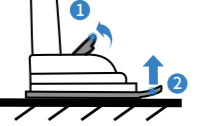

Tips 2

Dashboard Pad Compatibility

- ✓ For **NOT SMOOTH** surface, please must use the 3M dashboard pad
- ✗ Not compatible with **leather** or **vinyle** dashboard

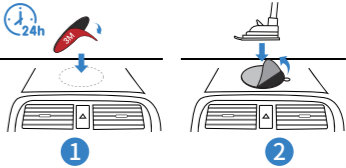

- 2 -
- 3 -
- 4 -
- 5 -
- 5 -

Tips 3

Remove Dashboard Disk Pad

Step1: Lift carefully the dashboard pad.
Step2: Use a thin plastic card to slowly separate the adhesive from the dashboard.

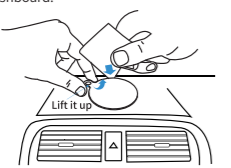

Tips 4

Re-Usable Suction Cup



Restore stickiness with warm water and let it air dry to use

Tips 5

Applicable instructions

Option 1: For iPhone 12/13 Series

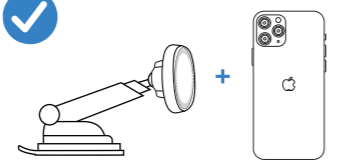

Option 2: For Official Magsafe Case

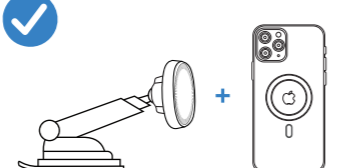

Option 3: For Non-Official Phone Case

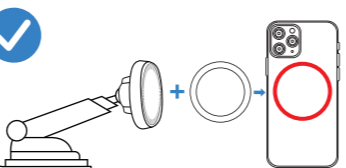

Stick the metal ring **on the center** of back of the phone case

Not Compatible

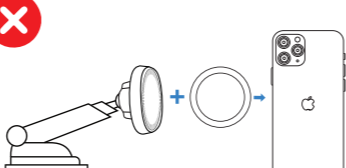

For iPhone 12/13 series without case, please **DO NOT** stick metal ring to phone directly

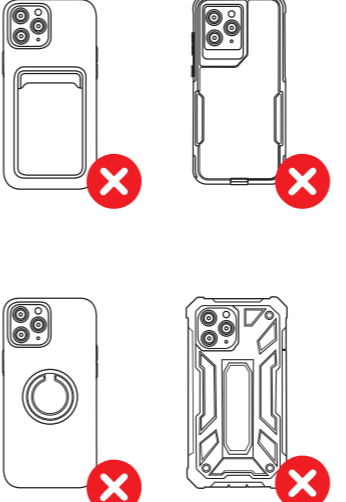

FCC Warning Statement

Changes or modifications not expressly approved by the party responsible for compliance could void the user's authority to operate the equipment. This equipment has been tested and found to comply with the limits for a Class B digital device, pursuant to Part 15 of the FCC Rules. These limits are designed to provide reasonable protection against harmful interference in a residential installation. This equipment generates uses and can radiate radio frequency energy and, if not installed and used in accordance with the instructions, may cause harmful interference to radio communications. However, there is no guarantee that interference will not occur in a particular installation. If this equipment does cause harmful interference to radio or television reception, which can be determined by turning the equipment off and on, the user is encouraged to try to correct the interference by one or more of the following measures:

- Reorient or relocate the receiving antenna.
- Increase the separation between the equipment and receiver.
- Connect the equipment into an outlet on a circuit different from that to which the receiver is connected.
- Consult the dealer or an experienced radio/TV technician for help.

This device complies with part 15 of the FCC Rules. Operation is subject to the following two conditions:
(1) This device may not cause harmful interference, and
(2) this device must accept any interference received, including interference that may cause undesired operation.

RF Exposure Statement
To maintain compliance with FCC's RF Exposure guidelines, This equipment should be installed and operated with minimum distance of 20cm the radiator your body. This device and its antenna(s) must not be co-located or operation in conjunction with any other antenna or transmitter

Dear Customer

If you have any question
please do not hesitate to
contact us at anytime
we are always here if you need!

- 6 -
- 7 -
- 8 -
- 9 -