

COMICA
PROFESSIONAL AUDIO EQUIPMENT

CVM-WS60 COMBO

UHF 1-Trigger-2 Flexible Mini Wireless Microphone



User Manual

FCC statement

This device complies with Part 15 of the FCC rules. Operation is subject to the following two conditions: 1) this device may not cause harmful interference, and 2) this device must accept any interference received, including interference that may cause undesired operation.

Note: This equipment has been tested and found to comply with the limits for a Class B digital device, pursuant to part 15 of the FCC Rules. These limits are designed to provide reasonable protection against harmful interference in a residential installation. This equipment generates uses and can radiate radio frequency energy and, if not installed and used in accordance with the instructions, may cause harmful interference to radio communications. However, there is no guarantee that interference will not occur in particular installation. If this equipment does cause harmful interference to radio or television reception, which can be determined by turning the equipment off and on, the user is encouraged to try to correct the interference by one or more of the following measures:

--Reorient or relocate the receiving antenna.

--Increase the separation between the equipment and receiver.

--Connect the equipment into an outlet on a circuit different from that to which the receiver is connected.

--Consult the dealer or an experienced radio/TV technician for help.

Changes or modifications not expressly approved by the party responsible for compliance could void the user's authority to operate the equipment.

FCC Radiation Exposure Statement

This device complies with FCC RF radiation exposure limits set forth for an uncontrolled environment. This transmitter must not be co-located or operating in conjunction with any other antenna or transmitter.

ISED Statement

- English: This device complies with Industry Canada license - exempt RSS standard(s). Operation is subject to the following two conditions: (1) This device may not cause interference, and (2) This device must accept any interference, including interference that may cause undesired operation of the device.

The digital apparatus complies with Canadian CAN ICES - 3 (B)/NMB - 3(B).

- French: Le présent appareil est conforme aux CNR d'Industrie Canada applicables aux appareils radio exempts de licence. L'exploitation est autorisée aux deux conditions suivantes: (1) l'appareil ne doit pas produire de brouillage, et (2) l'utilisateur de l'appareil doit accepter tout brouillage radioélectrique subi, même si le brouillage est susceptible d'en compromettre le fonctionnement.

l'appareil numérique du CIEM conforme canadien peut - 3 (b) / nmb - 3 (b).

This device meets the exemption from the routine evaluation limits in section 2.5 of RSS 102 and compliance with RSS 102 RF exposure, users can obtain Canadian information on RF exposure and compliance.

cet appareil est conforme à l'exemption des limites d'évaluation courante dans la section 2.5 du CNR - 102 et conformité avec RSS 102 de l'exposition aux RF, les utilisateurs peuvent obtenir des données canadiennes sur l'exposition aux champs RF et la conformité.

This equipment complies with Canada radiation exposure limits set forth for an uncontrolled environment. This equipment should be installed and operated with minimum distance 20cm between the radiator & your body. **(Receiver)**

Cet équipement est conforme Canada limites d'exposition aux radiations dans un environnement non contrôlé. Cet équipement doit être installé et utilisé à distance minimum de 20cm entre le radiateur et votre corps. **(Receiver)**

This device meets the exemption from the routine evaluation limits in section 2.5 of RSS 102 and compliance with RSS 102 RF exposure, users can obtain Canadian information on RF exposure and compliance.

cet appareil est conforme à l'exemption des limites d'évaluation courante dans la section 2.5 du CNR - 102 et conformité avec RSS 102 de l'exposition aux RF, les utilisateurs peuvent obtenir des données canadiennes sur l'exposition aux champs RF et la conformité.

This equipment complies with Canada radiation exposure limits set forth for an uncontrolled environment. This equipment should be installed and operated with minimum distance 0mm between the radiator & your body. **(launcher)**

Cet équipement est conforme Canada limites d'exposition aux radiations dans un environnement non contrôlé. Cet équipement doit être installé et utilisé à distance minimum de 0mm entre le radiateur et votre corps. **(launcher)**

The following text shall be included in the device's user manual:

This device operates on a no-interference, no-protection basis. Should the user seek to obtain protection from other radio services operating in the same TV bands, a radio licence is required. For further details, consult Innovation, Science and Economic Development Canada's Client Procedures Circular CPC-2-1-28, Voluntary Licensing of Licence-Exempt Wireless Microphones in the TV Bands.

Foreword

Thanks for purchasing COMICA WS60 COMBO UHF Dual-channel flexible mini wireless microphone.

To ensure the correct use and safety of the product, please carefully read this instruction before using and properly assemble and operate.

Main Features

- . Dual-channel Wireless Microphone, Universal for Smartphone & Camera
- . Built-in Rechargeable Lithium Battery and Metal Smartphone Holder
- . Working Distance Up to 60m (Open Area, 30m in Area with Obstacle)
- . 12 Channels for Multiple Devices Work Together
- . M/S Switch, Stepless Gain Adjustment, Muting Functions
- . Real-time Monitor, Audio Dynamic Bar
- . Lattice LCD Display, High Resolution

Notice

- ⚠ Transmitter should be used more than 20cm from Receiver, when the distance is less than 20cm, Receiver's wireless signal receiving part will take protect action to shut down wireless signal receiving, then audio may be intermittent, which is normal.
- ⚠ In the case of stereo/mono mode switch, please preset the mode before using to avoid the transient interference caused by switching during usage.
- ⚠ The product utilizes TRRS-TRRS output cable, different with most TRS-TRS, or TRS-TRRS output cables in the marketplace, cannot use it universally.
- ⚠ The working distance will be affected by the surrounding environment. Please try to keep the environment open without interference during usage.
- ⚠ Do not use this equipment in the vicinity of heat source or interference source, such as radiator, oven, refrigerator or air conditioner, smartphone, intercom or next to the WIFI AP.
- ⚠ Please keep this product in dry environment.
- ⚠ Do not expose the device in rain or humid environment, otherwise there will be a danger of short circuit.

Packing List

Main Parts:

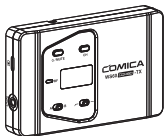

Lavalier Transmitter (TX)

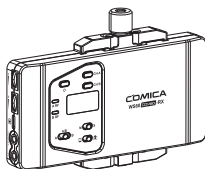

Receiver (RX)

Purchase Options:

WS60 COMBO= 2TX + RX



TX

+



TX

+

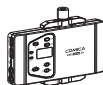

RX

Accessories:

- ① 3.5mm Mic Audio Input Cable
- ② 3.5mm TRRS -3.5mm TRRS Audio Output Cable
- ③ Belt Clip
- ④ Wind Muff
- ⑤ Portable Case
- ⑥ Ball Head
- ⑦ Tabletop Tripod
- ⑧ USB-C Charging Cable
- ⑨ User Manual
- ⑩ Warranty Card



①



②



③



④



⑤



⑥



⑦



⑧



⑨



⑩

Components

Lavalier Transmitter (TX)

- ① 1/4 Connecting Hole
- ② Reset Hole
- ③ Belt Clip Connection Hole
- ④ LCD Screen
- ⑤ Group Selection Switch
- ⑥ On-off / Muting Button
- ⑦ Matching / Muting Status Light Indicator
- ⑧ USB-C Charging Interface
- ⑨ MIC / LINE IN Input Jack
- ⑩ Group Switching Button
- ⑪ LCF (Low Cut Filter) Switch

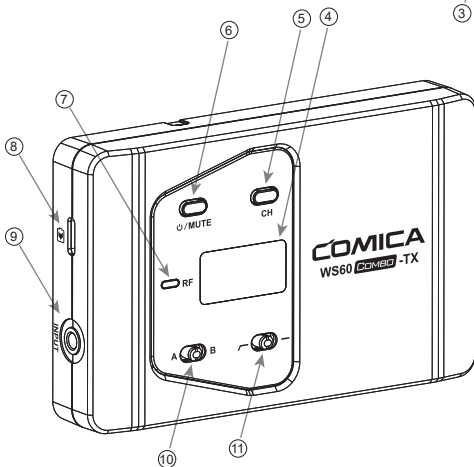
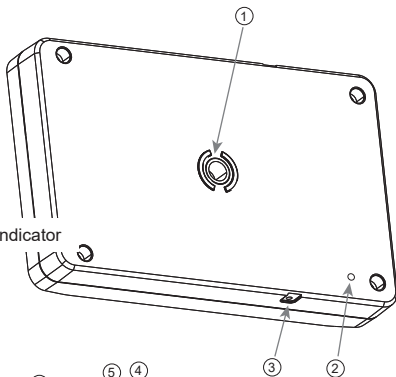



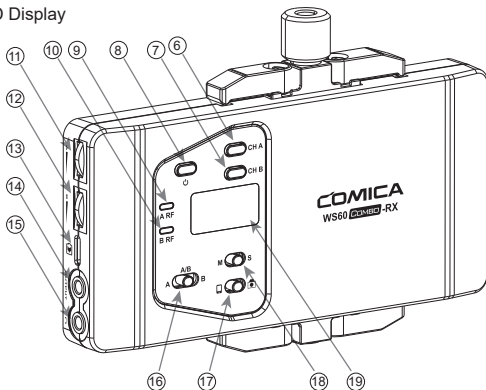
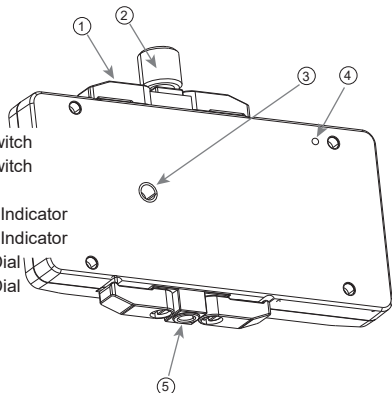

Receiver (RX)











- ① Smartphone Clamp
- ② Locking Screw
- ③ 1/4 Connecting Hole
- ④ Reset Hole
- ⑤ 1/4 Connecting Hole
- ⑥ Group A Channel Selection Switch
- ⑦ Group B Channel Selection Switch
- ⑧ On-off Button
- ⑨ Group A Working Status Light Indicator
- ⑩ Group B Working Status Light Indicator
- ⑪ Group A Volume Adjustment Dial
- ⑫ Group B Volume Adjustment Dial
- ⑬ USB-C Charging Interface
- ⑭ 3.5mm Audio Output Jack
- ⑮ 3.5mm Monitoring Jack
- ⑯ Group Switching Button
- ⑰ Smartphone/Camera Switching Button
- ⑱ Mono/Stereo Switching Button
- ⑲ LCD Display

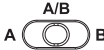

Function Button Instruction

<p>Lavalier Transmitter (TX)</p> 	<p>On-off/Muting Button</p>  <p>⏻/MUTE</p>	<p>Long Press</p>	<p>Power ON/OFF</p>
		<p>Short Press</p>	<p>Muting Mode (The Mute Mode only works after the screen lighted up)</p>
	<p>Channel Selection Switch</p>  <p>CH</p>	<p>Short Press</p>	<p>Channel Selection</p>
	<p>Group Switching Button</p> <p>A  B</p>	<p>Push</p>	<p>Left is Group A Right is Group B</p>
<p>LCF Switch</p> 	<p>Push</p>	<p>↙ Is Low Cut Mode — Normal Recording</p>	

👉 low-cut function will filter out the low-frequency part of the audio source, such as the chirping and crowd noise, and the main audio source will be more crisp. Turn off the low cut to restore the true, the main source will be more vigorous, but it can be adjusted according to actual needs.

	<p>On-Off Button</p> 	<p>Long Press</p>	<p>Power ON/OFF</p>
	<p>Channel Selection Switch</p> 	<p>Short Press</p>	<p>Press CH A is to select Group A's Channel Press CH B is to select Group B's Channel</p>
	<p>Group Switching Button</p> 	<p>Push</p>	<p>Push left to A , Open Group A only Push to middle A/B , Open both Group A and Group B Push right to B , Open Group B only</p>
	<p>Mono/Stereo Switch</p> 	<p>Push</p>	<p>M Mono Mode S Stereo Mode</p>
	<p>Smartphone/Camera Switching Button</p> 	<p>Turn</p>	<p> Smartphone Mode  Camera Mode</p>
	<p>Group Volume Adjustment</p> 	<p>Turn</p>	<p>A  Group A volume adjustment B  Group B volume adjustment</p>

 Due to mobilephone's input limitation of external mic, stereo mode only supports camera but not mobile phones. Stereo will be automatically identified as mono while in mobile phone working mode.

Screen Display

Lavalier Transmitter

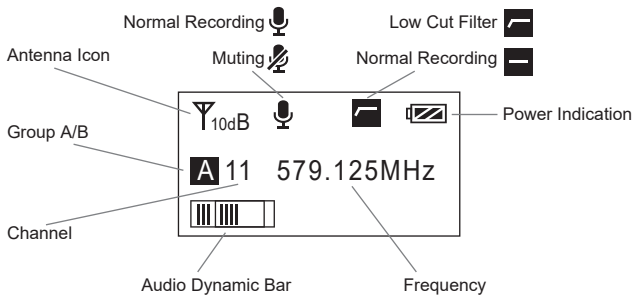

Receiver

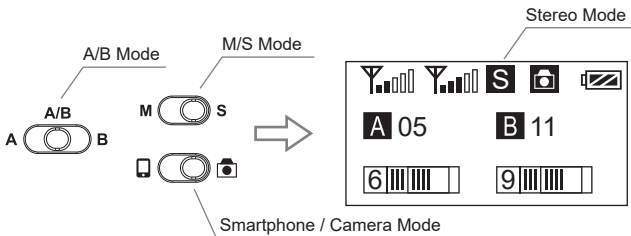
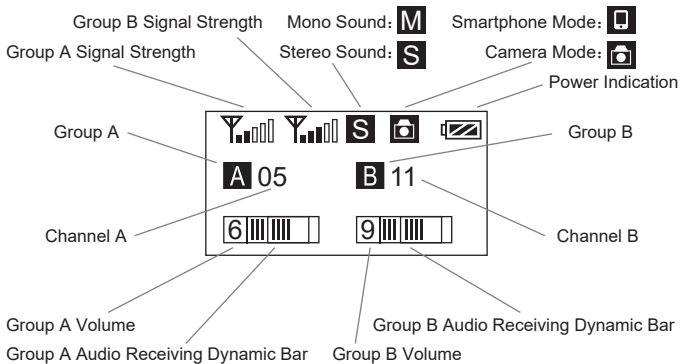

Indicator Light Instruction

Lavalier Transmitter (TX)	RF	Green Light Keeps on	Normal Recording Status (The status works for transmitter only. The receiver can pick up the sound when channel matched successfully.)
		Red Light Keeps on	Muting Mode
		Red Light Flickers	Low- power Reminder
Receiver (RX)	A RF	Green Light Keeps on	Normal working status after channel matched successfully
		Red Light Flickers	Channel matching is unsuccessful
	B RF	Green Light Flickers	Low-power Reminder
		Red Light Keeps on	Group closed



A RF: Group A working status light indicator

B RF: Group B working status light indicator

The matching methods of Receiver and Transmitter

1. Switch the Receiver's Group to "A", "B" or "A/B", then switch the transmitter's Group to corresponding "A" or "B"

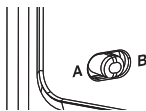

(Lavallier Transmitter)

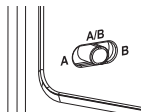

(Receiver)

- 👉 Single-channel: Switch the Receiver's Group to "A" or "B"
Dual-channel: Switch the Receiver's Group to "A/B"

2. Adjust the same group's channel of receiver and transmitter to be consistent

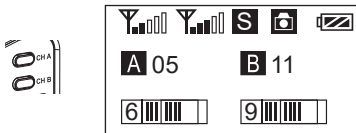

(Receiver)

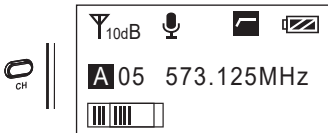

(Transmitter)

- 👉 When the working status light indicator keeps on in GREEN, it matched successfully

Lavalier Transmitter (TX)

1. Plug the USB-C charging cable into the USB-C charging interface then connect an external power for charging; Insert the reset pin into the reset hole to reset it when the device is crash

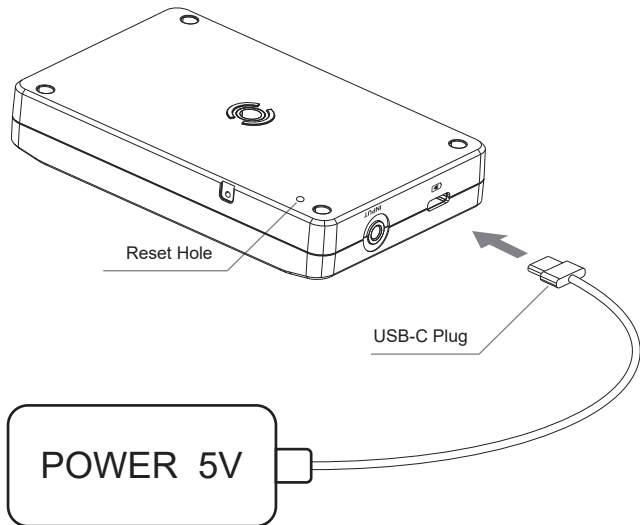

2. Insert the 3.5mm Mic Audio Input Cable into the MIC/ LINE IN Input Jack

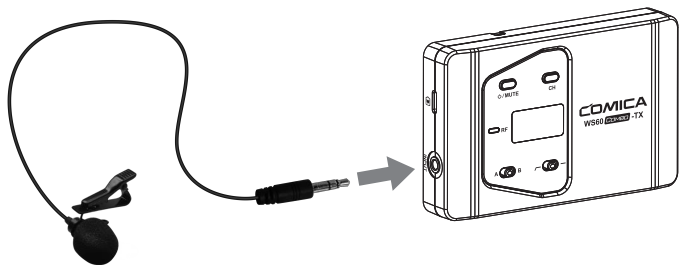

3. Long press the On-off Button to open the transmitter

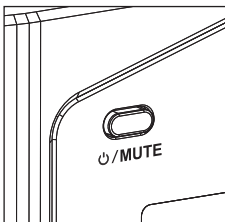

4. Target the Mic to the audio source and check whether the Lavalier Transmitter is working properly according to the audio display bar on the screen.

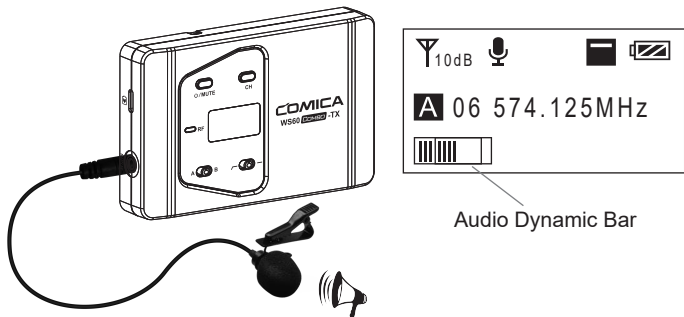

5. Connect the belt clip to the transmitter through the connection hole



6. It can be used after matched successfully with Receiver

 Please refer to the matching steps for channel matching

Receiver

1. Plug the USB-C charging cable into the USB-C charging interface then connect an external power for charging; Insert the reset pin into the reset hole to reset it when the device is crash

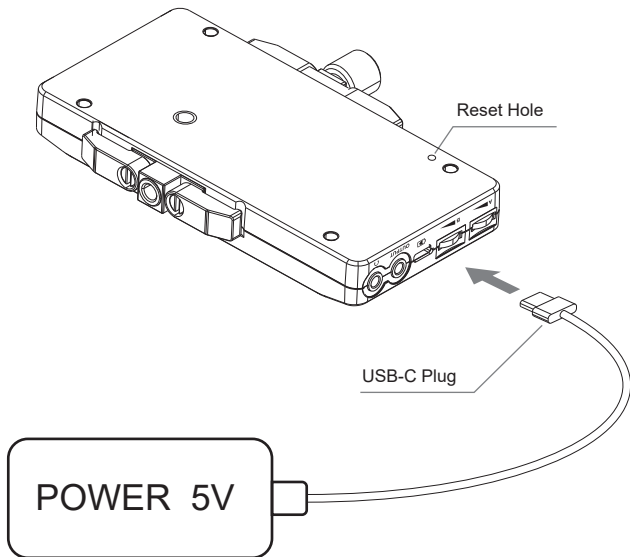

2. Using Methods

2.1 Method one: Using with Tripod

2.1.1 Connect Receiver and Tripod

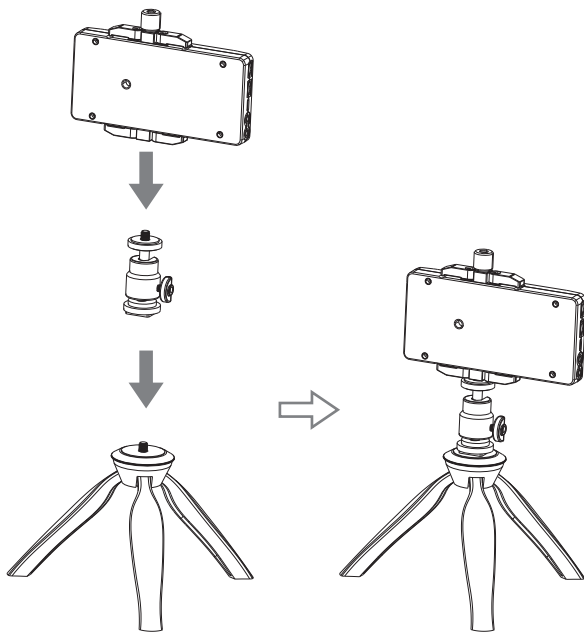

2.1.2 Rotate the four clamps to the front side.

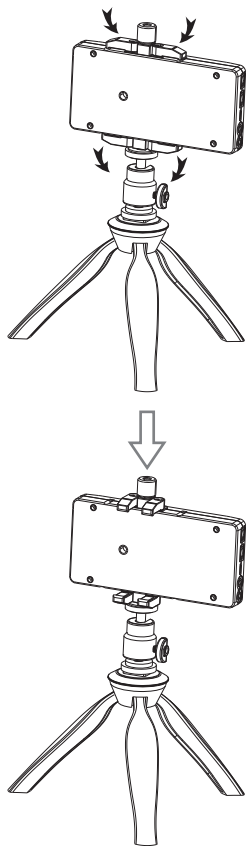

2.1.3 Fixing the locking screw to an appropriate height, then clamp your smartphone in a suitable position

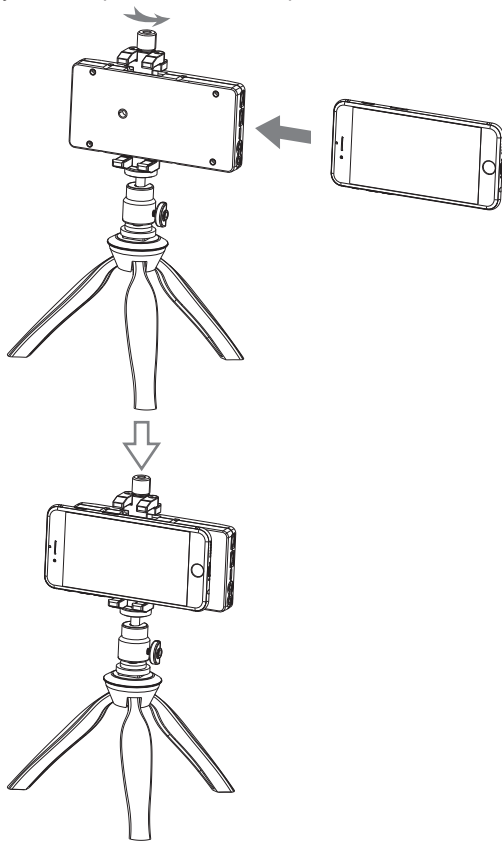

2.1.4 Rotate the locking screw until it fastened and fix your smartphone

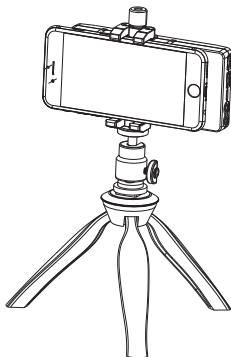
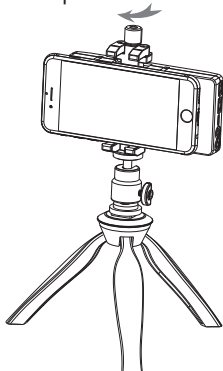

(Vertical Mode)

☞ It can be adjusted to different angles according to your needs

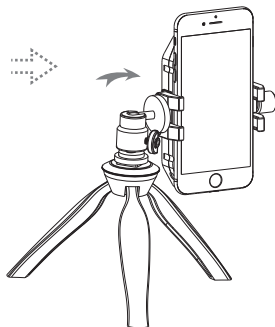

(Horizontal Mode)

2.1.5 Connect the receiver and your smartphone with 3.5mm-3.5mm Audio Output Cable

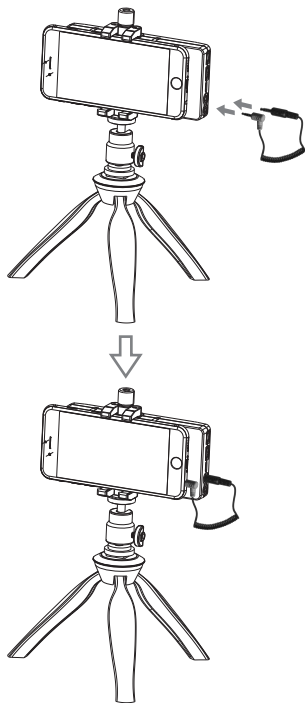

 This product uses 3.5mm TRRS output interface, phone with other interface should be prepared with corresponding adapter cable to use

2.1.6 Plug your earphone into “3.5mm monitoring jack” to realize real time monitoring

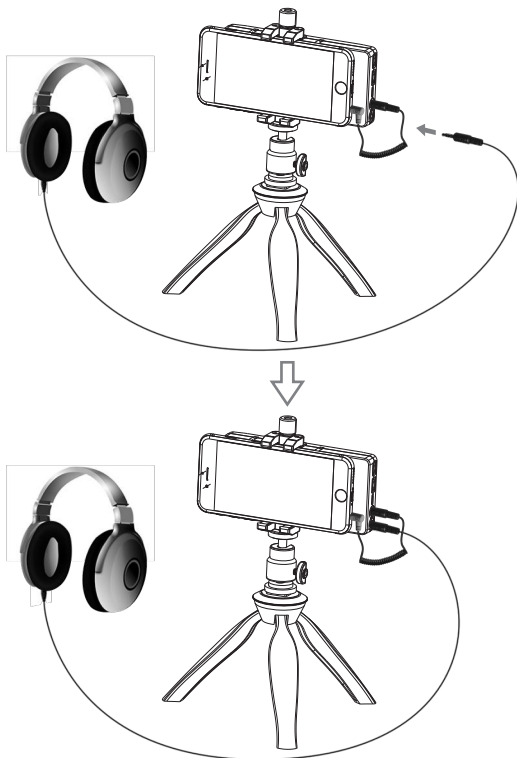

2.2 Method two: Using with your Camera

2.2.1 Connect your Camera to the Receiver with the ball head

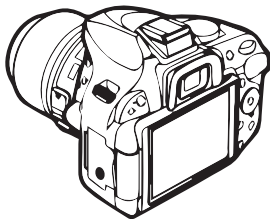
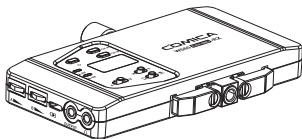

2.2.2 Insert the Mic Audio Input Cable into the 3.5mm jack of the Receiver and your Camera respectively

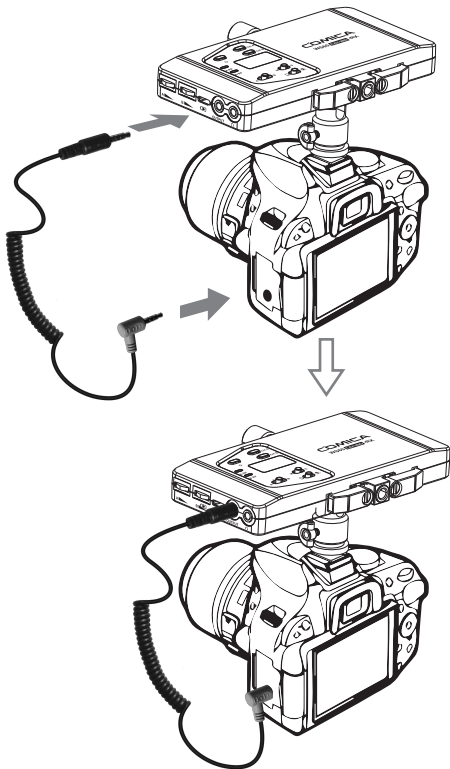

2.2.3 Plug your earphone into “ 3.5mm monitoring jack” to realize real time monitoring

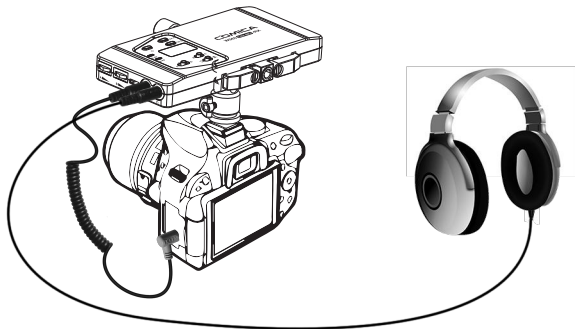
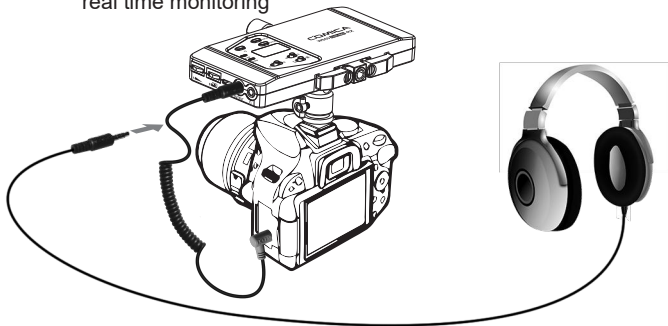

3. It can be used after channel matched successfully with Transmitter



Please refer to the matching steps for channel matching

Specification

Lavalier Transmitter (TX)

Channel	12
Duration	8 hours
Antenna	Built-in Antenna
Stray Radiation	< -60dBc
Sound Delay	< 20ms
Audio Distortion	< 0.5%
Signal/ Noise	> 65dB
Audio Input Socket	3.5mm TRS
Battery	Li-po Battery 1150mAh 3.7V
Dimension	104×65.2×18mm
Working Temperature	0°C~+50°C
Storage Temperature	-20°C~+60°C



www.comica-audio.com