



TEST REPORT

FCC PART 15.236

Report Reference No.....: **CTL2103261016-WF**

Compiled by: Happy Guo
(position+printed name+signature) (File administrators)

Happy Guo

Tested by: Nice Nong
(position+printed name+signature) (Test Engineer)

Nice Nong

Approved by: Ivan Xie
(position+printed name+signature) (Manager)

Ivan Xie

Product Name.....: UHF 6-channels Mini & Flexible Wireless Microphone

Model/Type reference.....: CVM-WS50

List Model(s).....: CVM-WS50(A), CVM-WS50(B), CVM-WS50(C)

Trade Mark.....: COMICA

FCC ID.....: 2AZSQ-CVM-WS50

Applicant's name.....: **Shenzhen Commlite Technology Co.,LTD.**

Address of applicant.....: 5th Floor, Building B, NO. 167 Pingxin North Road, Pinghu Street, Long'gang District, Shenzhen, Guangdong Province, China

Test Firm.....: **Shenzhen CTL Testing Technology Co., Ltd.**

Address of Test Firm.....: Floor 1-A, Baisha Technology Park, No.3011, Shahexi Road, Nanshan District, Shenzhen, China 518055

Test specification.....:

Standard.....: **FCC Part 15.236:**Operation of wireless microphones in the bands 54-72 MHz, 76-88 MHz, 174-216 MHz, 470-608 MHz and 614-698 MHz

TRF Originator.....: Shenzhen CTL Testing Technology Co., Ltd.

Master TRF.....: Dated 2011-01

Date of receipt of test item.....: Apr. 30, 2021

Date of sampling.....: Apr. 30, 2021

Date of Test Date.....: Apr. 30, 2021–May. 21, 2021

Data of Issue.....: May. 24, 2021

Result.....: **Pass**

Shenzhen CTL Testing Technology Co., Ltd. All rights reserved.

This publication may be reproduced in whole or in part for non-commercial purposes as long as the Shenzhen CTL Testing Technology Co., Ltd. is acknowledged as copyright owner and source of the material. Shenzhen CTL Testing Technology Co., Ltd. takes no responsibility for and will not assume liability for damages resulting from the reader's interpretation of the reproduced material due to its placement and context.

TEST REPORT

Test Report No. :	CTL2103261016-WF	May. 24, 2021
		Date of issue

Equipment under Test : UHF 6-channels Mini & Flexible Wireless Microphone

Sample No. CTL210326101-6-S003

Model /Type : CVM-WS50

Listed Models : CVM-WS50(A), CVM-WS50(B), CVM-WS50(C)

Applicant : **Shenzhen Commlite Technology Co.,LTD.**

Address : 5th Floor, Building B, NO. 167 Pingxin North Road,
Pinghu Street, Long'gang District, Shenzhen,
Guangdong Province, China

Manufacturer : **Shenzhen Commlite Technology Co.,LTD.**

Address : 5th Floor, Building B, NO. 167 Pingxin North Road,
Pinghu Street, Long'gang District, Shenzhen,
Guangdong Province, China

Test result	Pass *
--------------------	---------------

* In the configuration tested, the EUT complied with the standards specified page 5.

The test results presented in this report relate only to the object tested.

This report shall not be reproduced, except in full, without the written approval of the issuing testing laboratory.

Table of Contents

Page

1.	SUMMARY.....	6
1.1.	TEST STANDARDS.....	6
1.2.	TEST DESCRIPTION.....	6
1.3.	TEST FACILITY.....	6
1.4.	STATEMENT OF THE MEASUREMENT UNCERTAINTY.....	7
2.	GENERAL INFORMATION.....	8
2.1.	ENVIRONMENTAL CONDITIONS.....	8
2.2.	GENERAL DESCRIPTION OF EUT.....	8
2.3.	DESCRIPTION OF TEST MODES AND TEST FREQUENCY.....	8
2.4.	EQUIPMENTS USED DURING THE TEST.....	9
2.5.	RELATED SUBMITTAL(S) / GRANT(S).....	9
2.6.	MODIFICATIONS.....	9
3.	TEST CONDITIONS AND RESULTS.....	10
3.1.	CONDUCTED EMISSIONS TEST.....	10
3.2.	RADIATED EMISSIONS AND BAND EDGE.....	13
3.3.	MAXIMUM OUTPUT POWER.....	14
3.4.	OCCUPIED BANDWIDTH MEASUREMENT.....	16
3.5.	NECESSARY BANDWIDTH.....	18
3.6.	TRANSMITTER SPURIOUS EMISSIONS.....	21
3.7.	FREQUENCY STABILITY.....	24
4.	TEST SETUP PHOTOS OF THE EUT.....	26
5.	EXTERNAL AND INTERNAL PHOTOS OF THE EUT.....	28

1. SUMMARY

1.1. TEST STANDARDS

The tests were performed according to following standards:

FCC Rules Part 15.236: Operation of wireless microphones in the bands 54-72 MHz, 76-88 MHz, 174-216 MHz, 470-608 MHz and 614-698 MHz

ANSI C63.10:2013: American National Standard for Testing Unlicensed Wireless Devices

According to KDB 206256 D01 Wireless Microphone Certification v02.

1.2. Test Description

Test Specification clause		
FCC Part 15.207	AC Power Conducted Emission	PASS
FCC Part 15.236(d)	RF Power Output	PASS
FCC Part 15.236(f)(2)	Occupied Bandwidth	PASS
FCC Part 15.236(g) ETSI EN 300 422-1 v1.4.2	Necessary Bandwidth Spurious emissions	PASS
FCC Part 15.236(f)(3)	Frequency Stability	PASS

1.3. Test Facility

1.3.1 Address of the test laboratory

Shenzhen CTL Testing Technology Co., Ltd.

Floor 1-A, Baisha Technology Park, No. 3011, Shahexi Road, Nanshan, Shenzhen 518055 China

There is one 3m semi-anechoic chamber and two line conducted labs for final test. The Test Sites meet the requirements in documents ANSIC63.10 requirements.

1.3.2 Laboratory accreditation

The test facility is recognized, certified, or accredited by the following organizations:

CNAS-Lab Code: L7497

Shenzhen CTL Testing Technology Co., Ltd. has been assessed and proved to be in compliance with CNAS-CL01 Accreditation Criteria for Testing and Calibration Laboratories (identical to ISO/IEC 17025: 2005 General Requirements) for the Competence of Testing and Calibration Laboratories.

A2LA-Lab Cert. No. 4343.01

Shenzhen CTL Testing Technology Co., Ltd, EMC Laboratory has been accredited by A2LA for technical competence in the field of electrical testing, and proved to be in compliance with ISO/IEC 17025: 2005 General Requirements for the Competence of Testing and Calibration Laboratories and any additional program requirements in the identified field of testing.

IC Registration No.: 9618B

CAB identifier: CN0041

The 3m alternate test site of Shenzhen CTL Testing Technology Co., Ltd. EMC Laboratory has been registered by Innovation, Science and Economic Development Canada to test to Canadian radio equipment requirements with Registration No.: 9618B on Jan.22, 2019.

1.4. Statement of the measurement uncertainty

The data and results referenced in this document are true and accurate. The reader is cautioned that there may be errors within the calibration limits of the equipment and facilities. The measurement uncertainty was calculated for all measurements listed in this test report acc. to CISPR 16 - 4 „Specification for radio disturbance and immunity measuring apparatus and methods – Part 4: Uncertainty in EMC Measurements“ and is documented in the Shenzhen CTL Testing Technology Co., Ltd. quality system acc. to DIN EN ISO/IEC 17025. Furthermore, component and process variability of devices similar to that tested may result in additional deviation. The manufacturer has the sole responsibility of continued compliance of the device.

Hereafter the best measurement capability for CTL laboratory is reported:

Test	Measurement Uncertainty	Notes
Transmitter power conducted	± 0.57 dB	(1)
Transmitter power Radiated	± 2.20 dB	(1)
Conducted spurious emission 9KHz-40 GHz	± 2.20 dB	(1)
Occupied Bandwidth	± 0.01 ppm	(1)
Radiated Emission 30~1000MHz	± 4.10 dB	(1)
Radiated Emission Above 1GHz	± 4.32 dB	(1)
Conducted Disturbance 0.15~30MHz	± 3.20 dB	(1)

This uncertainty represents an expanded uncertainty expressed at approximately the 95% confidence level using a coverage factor of $k=2$.

2. GENERAL INFORMATION

2.1. Environmental conditions

During the measurement the environmental conditions were within the listed ranges:

Normal Temperature:	25°C
Relative Humidity:	55 %
Air Pressure:	101 kPa

2.2. General Description of EUT

Product Name:	UHF 6-channels Mini & Flexible Wireless Microphone
Model/Type reference:	CVM-WS50
Power supply:	DC 3.7V from battery
Hardware Version:	1.4
Software Version:	1.0.4
SRD	
Modulation:	FM
Operation frequency:	520MHz~526MHz
Channel number:	6
Channel separation:	1.2MHz
Antenna type:	Internal Antenna
Antenna gain:	2.53dBi

Note: For more details, please refer to the user's manual of the EUT.

2.3. Description of Test Modes and Test Frequency

The Applicant provides communication tools software to control the EUT for staying in continuous transmitting (Duty Cycle more than 98%) and receiving mode for testing. There are 6 channels provided to the EUT and Channel 01/06 were selected for testing.

Operation Frequency List :

Channel	Frequency (MHz)
01	520
02	521.2
03	522.4
04	523.6
05	524.8
06	526

Note: The line display in grey is the channel selected to perform test.

2.4. Equipments Used during the Test

Test Equipment	Manufacturer	Model No.	Serial No.	Calibration Date	Calibration Due Date
LISN	R&S	ESH2-Z5	860014/010	2021/05/13	2022/05/12
Bilog Antenna	Sunol Sciences Corp.	JB1	A061713	2021/04/06	2022/04/05
EMI Test Receiver	R&S	ESCI	1166.5950.03	2021/05/16	2022/05/15
Spectrum Analyzer	Agilent	E4407B	MY41440676	2021/05/13	2022/05/12
Spectrum Analyzer	Agilent	N9020A	US46220290	2021/05/13	2022/05/12
Spectrum Analyzer	Keysight	N9020A	MY53420874	2021/05/13	2022/05/12
Controller	EM Electronics	EM 1000	060859	2021/05/18	2022/05/17
Horn Antenna	Sunol Sciences Corp.	DRH-118	A062013	2021/05/18	2022/05/17
Active Loop Antenna	Da Ze	ZN30900A	/	2021/05/18	2022/05/17
Amplifier	Agilent	8449B	3008A02306	2021/05/13	2022/05/12
Amplifier	Agilent	8447D	2944A10176	2021/05/13	2022/05/12
Temperature/Humidity Meter	Gangxing	CTH-608	02	2021/05/13	2022/05/12
Power Sensor	Agilent	U2021XA	MY55130004	2021/05/13	2022/05/12
Power Sensor	Agilent	U2021XA	MY55130006	2021/05/13	2022/05/12
Spectrum Analyzer	RS	FSP	1164.4391.38	2021/05/13	2022/05/12
Audio signal generator	GOOD WILL INSTRUMENT	8121C	NS 021110854	2021/04/28	2022/04/27
Audio Analyzer	R&S	UPV	1146.2003K02-101721-UW	2021/04/28	2022/04/27
Test Software					
Name of Software			Version		
TST-PASS			1.0.5		
ES-K1(Below 1GHz)			V1.71		
e3(Above 1GHz)			6.111221a		

The calibration interval was one year

2.5. Related Submittal(s) / Grant(s)

This submittal(s) (test report) is intended to comply with Section 15.236 of the FCC Part 15, Subpart C Rules.

2.6. Modifications

No modifications were implemented to meet testing criteria.

3. TEST CONDITIONS AND RESULTS

3.1. Conducted Emissions Test

LIMIT

FCC CFR Title 47 Part 15 Subpart C Section 15.207

Frequency range (MHz)	Limit (dBuV)	
	Quasi-peak	Average
0.15-0.5	66 to 56*	56 to 46*
0.5-5	56	46
5-30	60	50

* Decreases with the logarithm of the frequency.

TEST CONFIGURATION

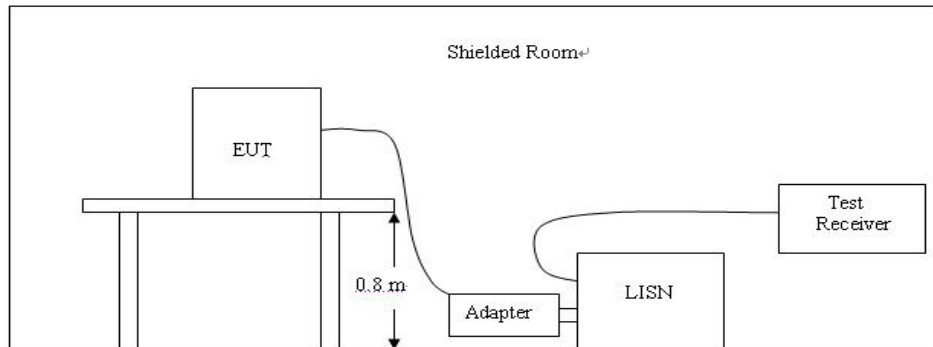

TEST PROCEDURE

1. The equipment was set up as per the test configuration to simulate typical actual usage per the user's manual. The EUT is a tabletop system; a wooden table with a height of 0.8 meters is used and is placed on the ground plane as per ANSI C63.10:2013.
2. Support equipment, if needed, was placed as per ANSI C63.10:2013.
3. All I/O cables were positioned to simulate typical actual usage as per ANSI C63.10:2013.
4. If a EUT received DC power from the USB Port of Notebook PC, the PC's adapter received AC120V/60Hz power through a Line Impedance Stabilization Network (LISN) which supplied power source and was grounded to the ground plane.
5. All support equipments received AC power from a second LISN, if any.
6. The EUT test program was started. Emissions were measured on each current carrying line of the EUT using a spectrum Analyzer / Receiver connected to the LISN powering the EUT. The LISN has two monitoring points: Line 1 (Hot Side) and Line 2 (Neutral Side). Two scans were taken: one with Line 1 connected to Analyzer / Receiver and Line 2 connected to a 50 ohm load; the second scan had Line 1 connected to a 50 ohm load and Line 2 connected to the Analyzer / Receiver.
7. Analyzer / Receiver scanned from 150 KHz to 30MHz for emissions in each of the test modes.
8. During the above scans, the emissions were maximized by cable manipulation.

TEST RESULTS

Remark: All modes were test at Low, Middle, and High channel; only the worst result of High Channel was reported as below:

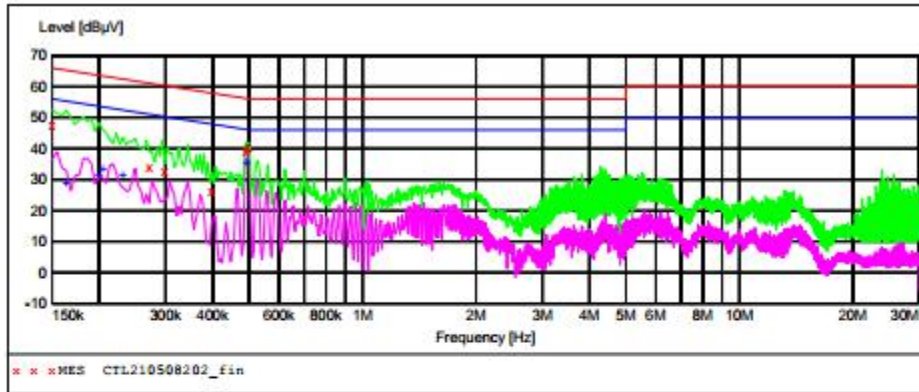

MEASUREMENT RESULT: "CTL210508202_fin"

5/8/2021 5:46PM

Frequency MHz	Level dBuV	Transd dB	Limit dBuV	Margin dB	Detector	Line	PE
0.150000	47.60	10.0	66	18.4	QP	L1	GND
0.271500	33.90	10.0	61	27.2	QP	L1	GND
0.298500	32.90	10.0	60	27.4	QP	L1	GND
0.397500	26.20	10.0	58	31.7	QP	L1	GND
0.492000	39.60	10.0	56	16.5	QP	L1	GND
0.496500	40.60	10.0	56	15.5	QP	L1	GND

MEASUREMENT RESULT: "CTL210508202_fin2"

5/8/2021 5:46PM

Frequency MHz	Level dBuV	Transd dB	Limit dBuV	Margin dB	Detector	Line	PE
0.163500	29.20	10.0	55	26.1	AV	L1	GND
0.199500	31.30	10.0	54	22.3	AV	L1	GND
0.204000	33.70	10.0	53	19.7	AV	L1	GND
0.231000	31.60	10.0	52	20.8	AV	L1	GND
0.492000	35.60	10.0	46	10.5	AV	L1	GND
0.496500	39.40	10.0	46	6.7	AV	L1	GND

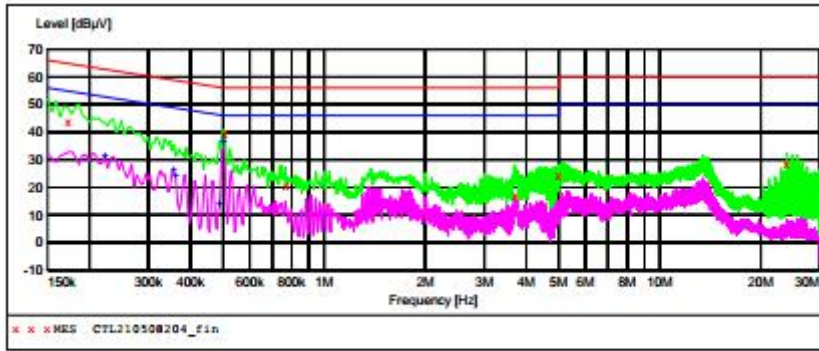

MEASUREMENT RESULT: "CTL210508204_fin"

5/8/2021 5:54PM

Frequency MHz	Level dBµV	Transd dB	Limit dBµV	Margin dB	Detector	Line	PE
0.172500	43.70	10.0	65	21.1	QP	N	GND
0.505500	39.80	10.1	56	16.2	QP	N	GND
0.771000	20.60	10.1	56	35.4	QP	N	GND
3.714000	16.90	10.3	56	39.1	QP	N	GND
4.987500	23.90	10.4	56	32.1	QP	N	GND
23.883000	28.50	11.4	60	31.5	QP	N	GND

MEASUREMENT RESULT: "CTL210508204_fin2"

5/8/2021 5:54PM

Frequency MHz	Level dBµV	Transd dB	Limit dBµV	Margin dB	Detector	Line	PE
0.222000	31.70	10.0	53	21.0	AV	N	GND
0.357000	26.10	10.0	49	22.7	AV	N	GND
0.361500	24.20	10.0	49	24.5	AV	N	GND
0.487500	14.00	10.0	46	32.2	AV	N	GND
0.501000	36.30	10.1	46	9.7	AV	N	GND

3.2. Radiated Emissions and Band Edge

Limit

Spurious emissions are emissions outside the frequency range(s) of the equipment. The power of the spurious emissions shall not exceed the limits of table as below:

State	Frequency		
	47 MHz to 74 MHz 87,5 MHz to 137 MHz 174 MHz to 230 MHz 470 MHz to 862 MHz	Other Frequencies below 1 000 MHz	Frequencies above 1 000 MHz
Operation	4 nW	250 nW	1 µW
Standby	2 nW	2 nW	20 nW

TEST CONFIGURATION

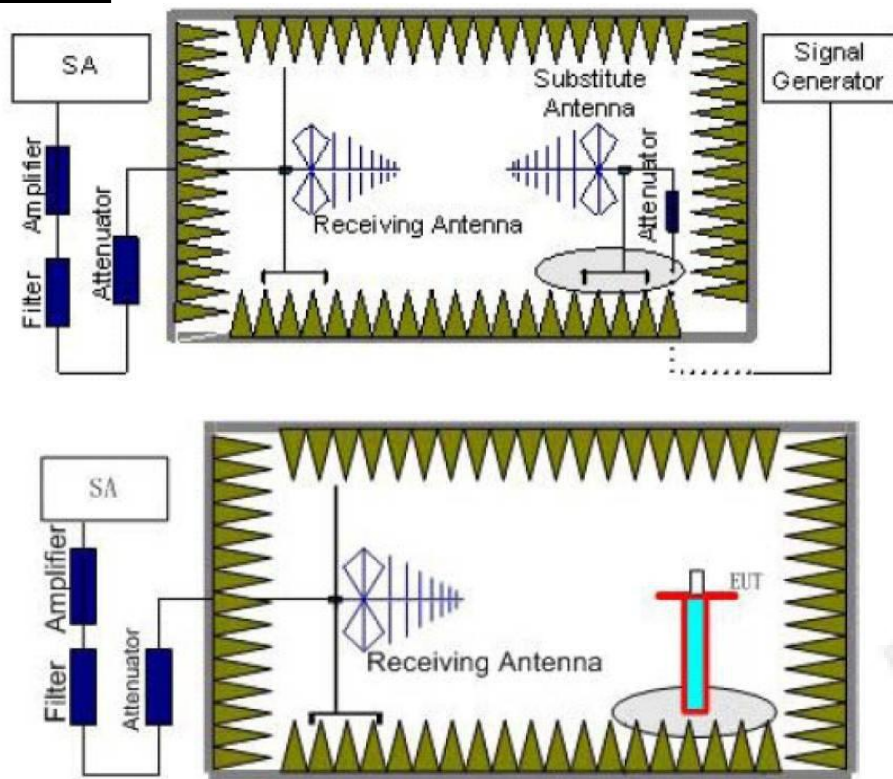

Test Procedure

1. Please refer to ETSI EN 300 422-1 V1.4.2 (2011-08) clause 6.1 for the test conditions.
2. Please refer to ETSI EN 300 422-1 V1.4.2 (2011-08) clause 8.4.2 for the measurement method.

TEST RESULTS

See page 22-23 of the report for the test results.

3.3. Maximum Output Power

Limit

The maximum radiated power shall not exceed the following values:

(1) In the bands allocated and assigned for broadcast television and in the 600 MHz service band: 50 mW EIRP

(2) In the 600 MHz guard band and the 600 MHz duplex gap: 20 mW EIRP.

Test Procedure

Remove the antenna from the EUT and then connect a low loss RF cable from the antenna port to the Spectrum Analyzer.

Test Configuration



Test Results

Modulation	Channel	Output power (dBm)	Ant. Gain (dBi)	EIRP (dBm)	Limit (dBm)	Result
FM	CH1	4.475	2.53	7.005	17	Pass
	CH6	4.684	2.53	7.214	17	Pass

Note: 1. The test results including the cable loss.
2. The RF cable is 50 ohm.

Test plot as follows:

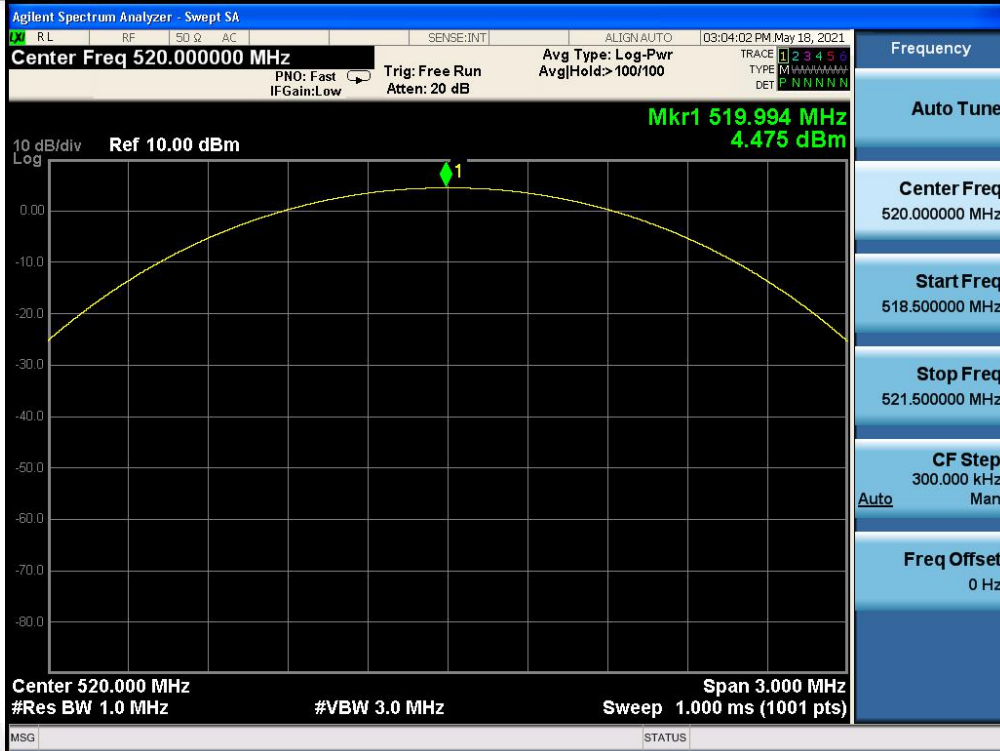

CH01

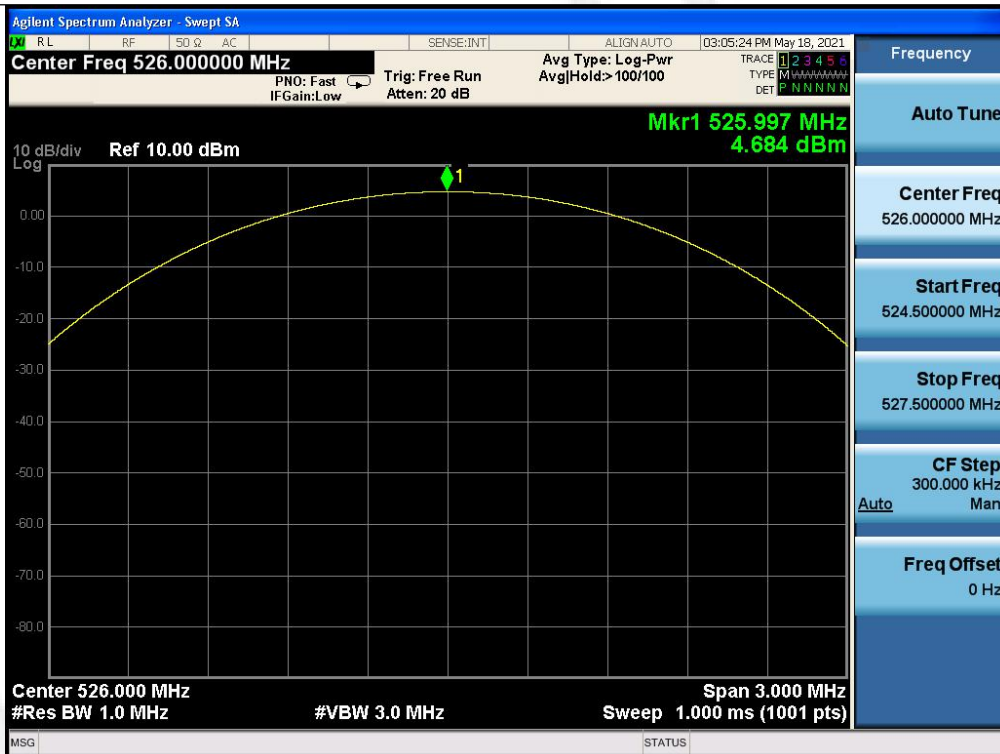

CH06

3.4. Occupied Bandwidth Measurement

Limit

One or more adjacent 25 kHz segments within the assignable frequencies may be combined to form a channel whose maximum bandwidth shall not exceed 200 kHz. The operating bandwidth shall not exceed 200 kHz.

Test Configuration



Test Procedure

The test shall be modulated by a 2500 Hz tone at an input level 16 dB greater than that necessary to produce 50 percent modulation.

Test Results

Modulation	Channel	99% OBW (KHz)	Limit (KHz)	Result
FM	CH01	54.922	200	Pass
	CH06	59.749	200	

Test plot as follows:

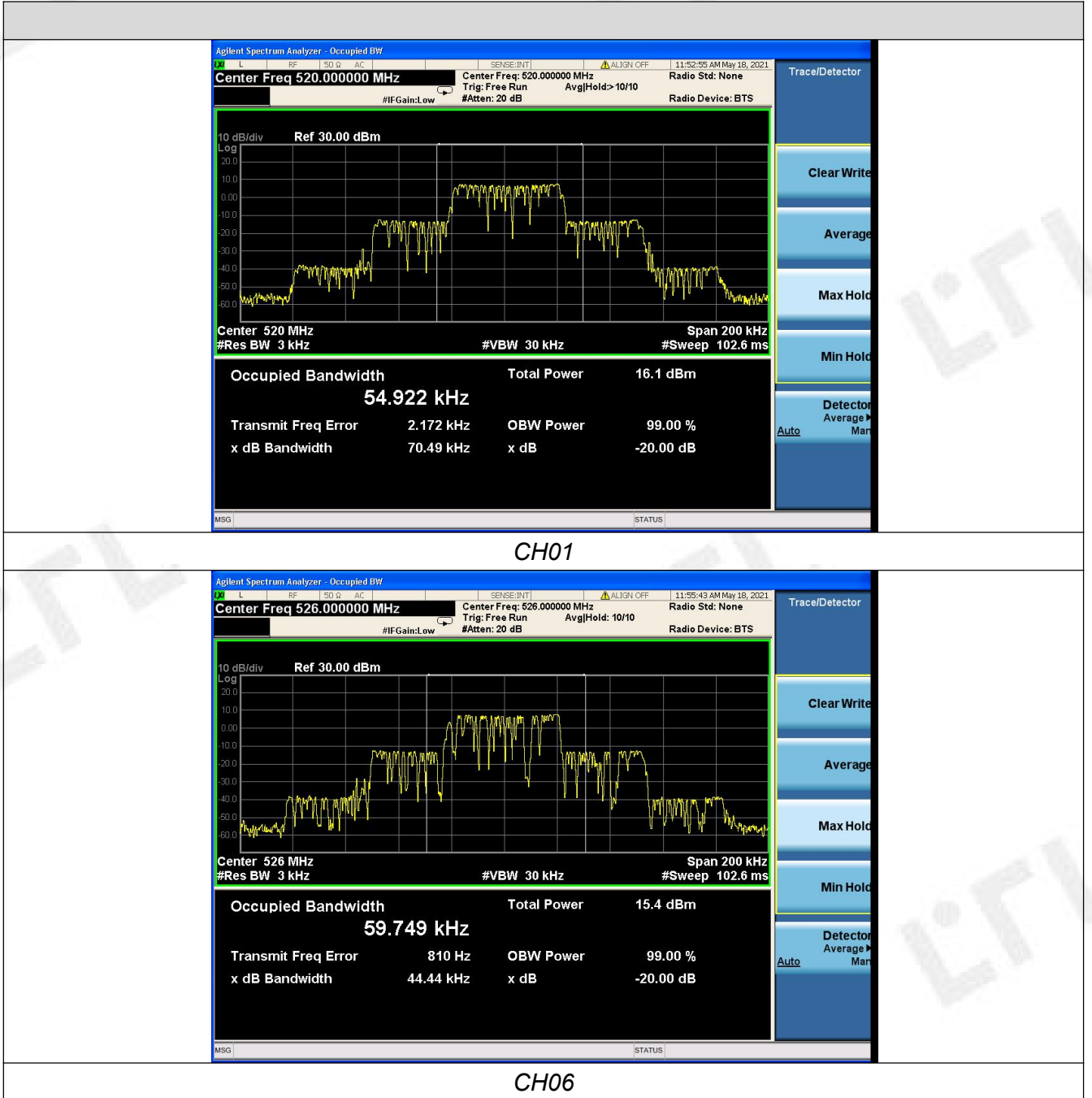

3.5. Necessary Bandwidth

LIMIT

According to ETSI EN 300 422-1 V2.1.2 (2017-01) section 8.3.2.2, the trum mask for all analogue systems in the band. The -90 dBc point shall be ± 1 MHz from f_c easured with an average detector. To comply, a measured value shall fall below the mask limit as shown in figure 3.

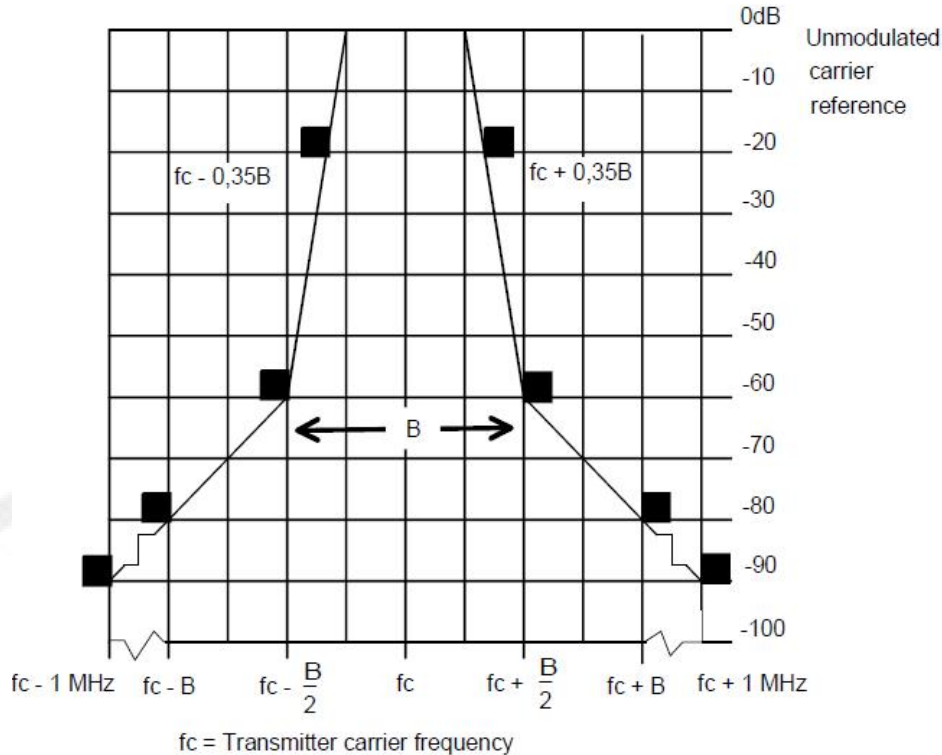

TEST PROCEDURE

The arrangement of test equipment as shown in figure B.1 shall be used. Note that the noise meter conforms to (quasi) without weighting filter (flat).

With the Low Frequency (LF) audio signal generator set to 500 Hz, the audio input level to the DUT shall be adjusted to 8 dB below the limiting threshold (-8 dB (lim)) as declared by the manufacturer. The corresponding audio output level from the demodulator shall be measured and recorded.

The input impedance of the noise meter shall be sufficiently high to avoid more than 0,1 dB change in input level when the meter is switched between input and output.

The audio input level shall be increased by 20 dB, i.e. to +12 dB (lim), and the corresponding change in output level shall be measured.

It shall be checked that the audio output level has increased by ≤ 10 dB.

If this condition is not met, the initial audio input level shall be increased from -8 dB (lim) in 1 dB steps until the above condition is fulfilled, and the input level recorded in the test report. This level replaces the value derived from the manufacturer's declaration and is defined as -8 dB (lim).

Measure the input level at the transmitter required to give +12 dB (lim).

The LF generator shall be replaced with the weighted noise source to Recommendation ITU-R BS.559-2 [i.3], band-limited to 15 kHz as described in IEC 60244-13 [2], and the level shall be adjusted such that the measured input to the transmitter corresponds to +12 dB (lim).

If the transmitter incorporates any ancillary coding or signalling channels (e.g. pilot-tones), these shall be enabled prior to any spectral measurements.

If the transmitter incorporates more than one audio input, e.g. stereo systems, the second and subsequent channels shall be simultaneously driven from the same noise source, attenuated to a level of -6 dB (lim).

The transmitter RF output spectrum shall be measured, using a spectrum analyser with the following settings:

- centre frequency: f_c : Transmitter (Tx) nominal frequency;
- dispersion (Span): $f_c - 1$ MHz to $f_c + 1$ MHz;
- Resolution BandWidth (RBW): 1 kHz;

- Video BandWidth (VBW): 1 kHz;
- detector: Peak hold.

TEST CONFIGURATION

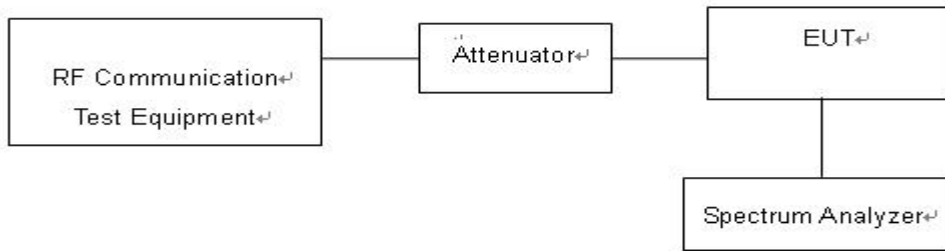

TEST RESULTS

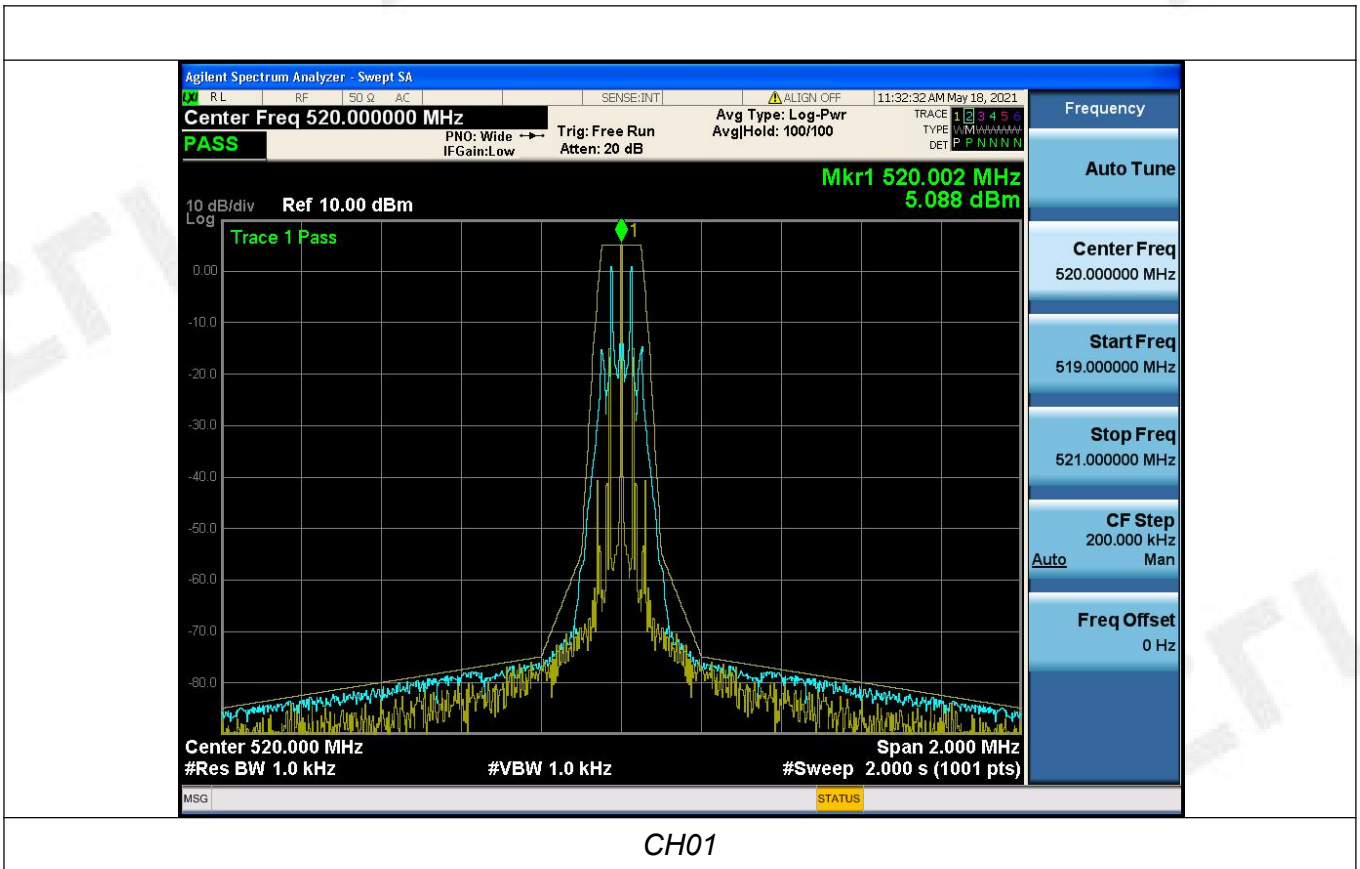

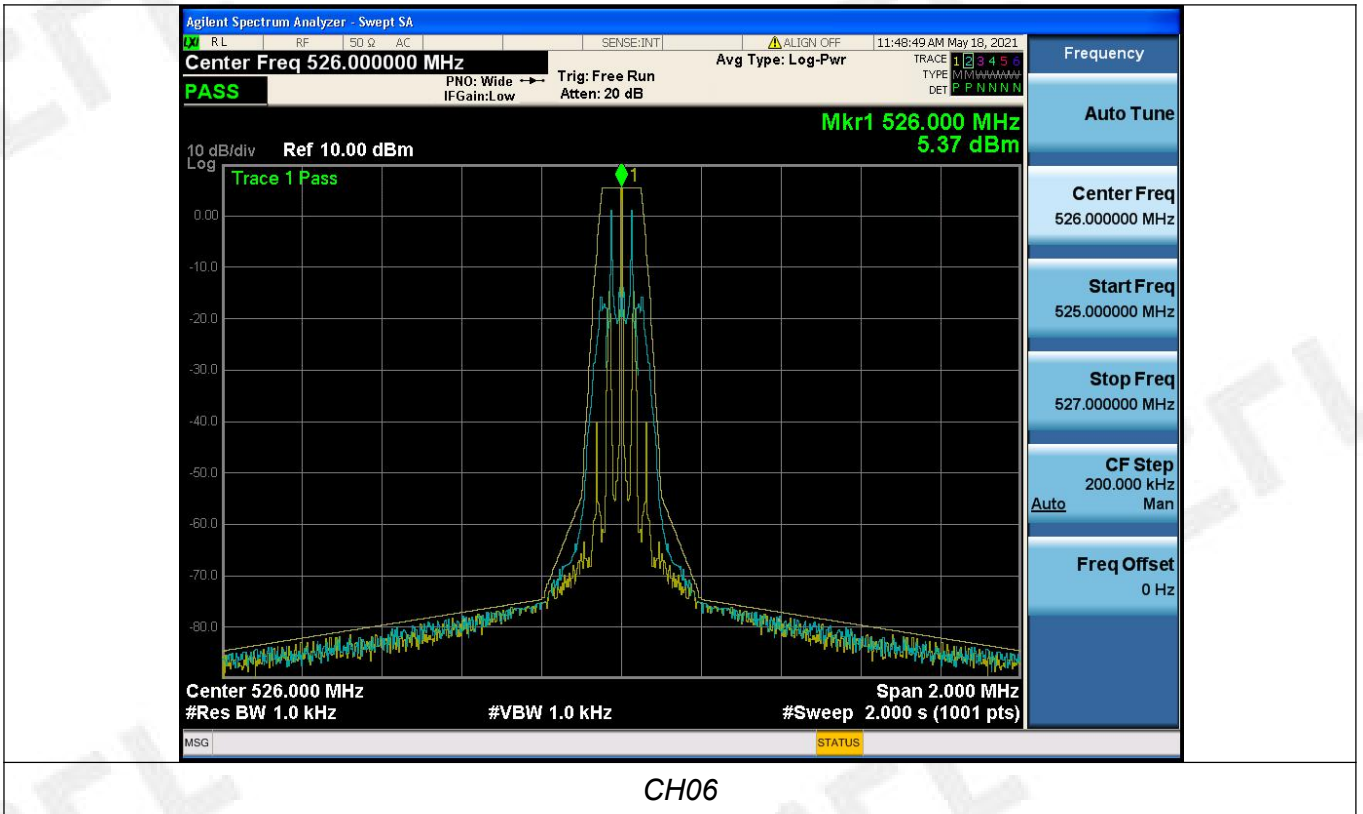

CH06

3.6. Transmitter spurious emissions

Limit

Spurious emissions are emissions outside the frequency range(s) of the equipment. The power of the spurious emissions shall not exceed the limits of table as below:

State	Frequency		
	47 MHz to 74 MHz 87,5 MHz to 137 MHz 174 MHz to 230 MHz 470 MHz to 862 MHz	Other Frequencies below 1 000 MHz	Frequencies above 1 000 MHz
Operation	4 nW	250 nW	1 μW
Standby	2 nW	2 nW	20 nW

Test Procedure

1. The EUT was placed on a turntable with 1.5m height.
2. The test distance between the receiving antenna and the EUT is 3 meter, while the receiving (test) antenna is kept at 1.5 meter height.
3. Set EUT in continuous transmitting with maximum output power at test frequency.
4. The table was rotated from 0 to 360 degree to search the highest radiated emission.
5. Repeat step 3 to 4 for each polarization and test channel to find the worst emission level.
6. The results obtained are compared to the limits in order to prove compliance with the requirement.

Test Configuration

Effective Radiated Power measurement (30 MHz to 12.75 GHz)

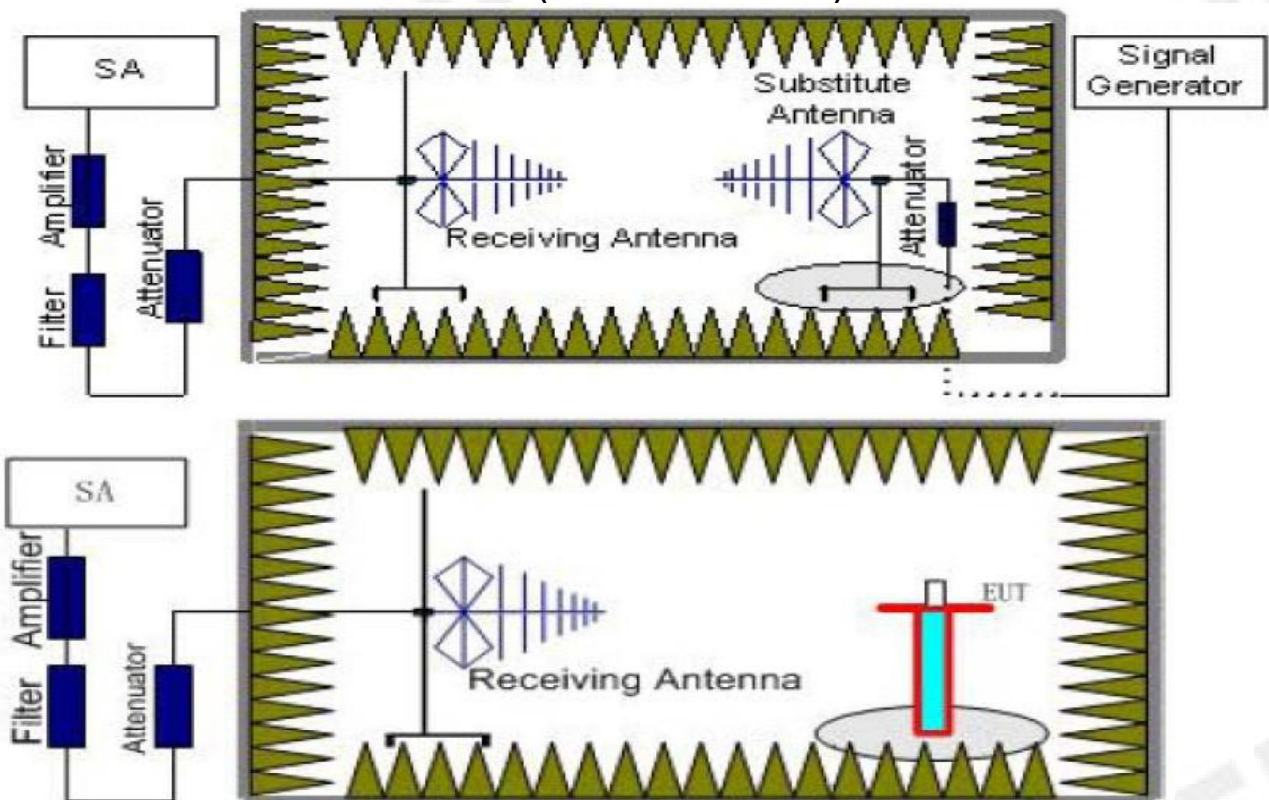

TEST PROCEDURE

1. Please refer to ETSI EN 300 422-1 V1.4.2 (2011-08) clause 6.1 for the test conditions.
2. Please refer to ETSI EN 300 422-1 V1.4.2 (2011-08) clause 8.4.2 for the measurement method.

Test Results

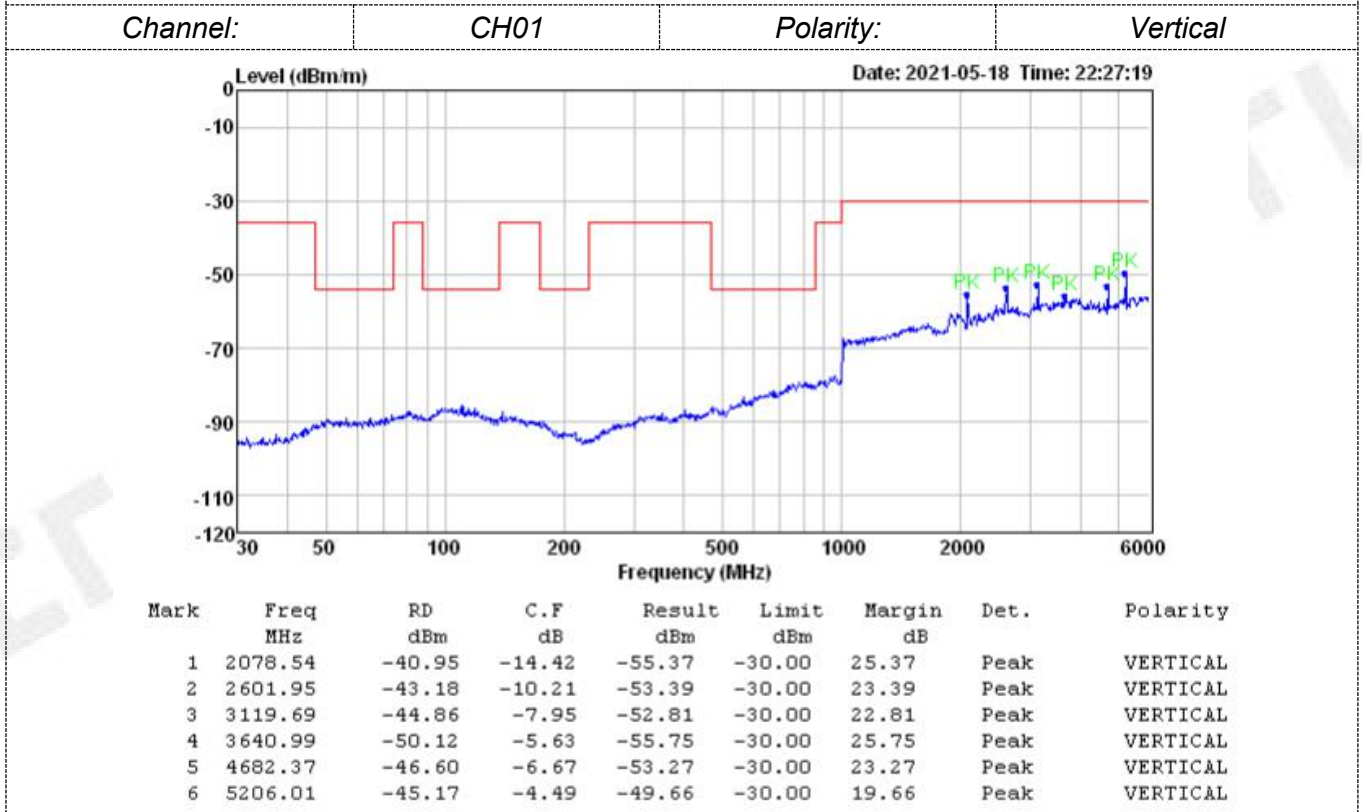
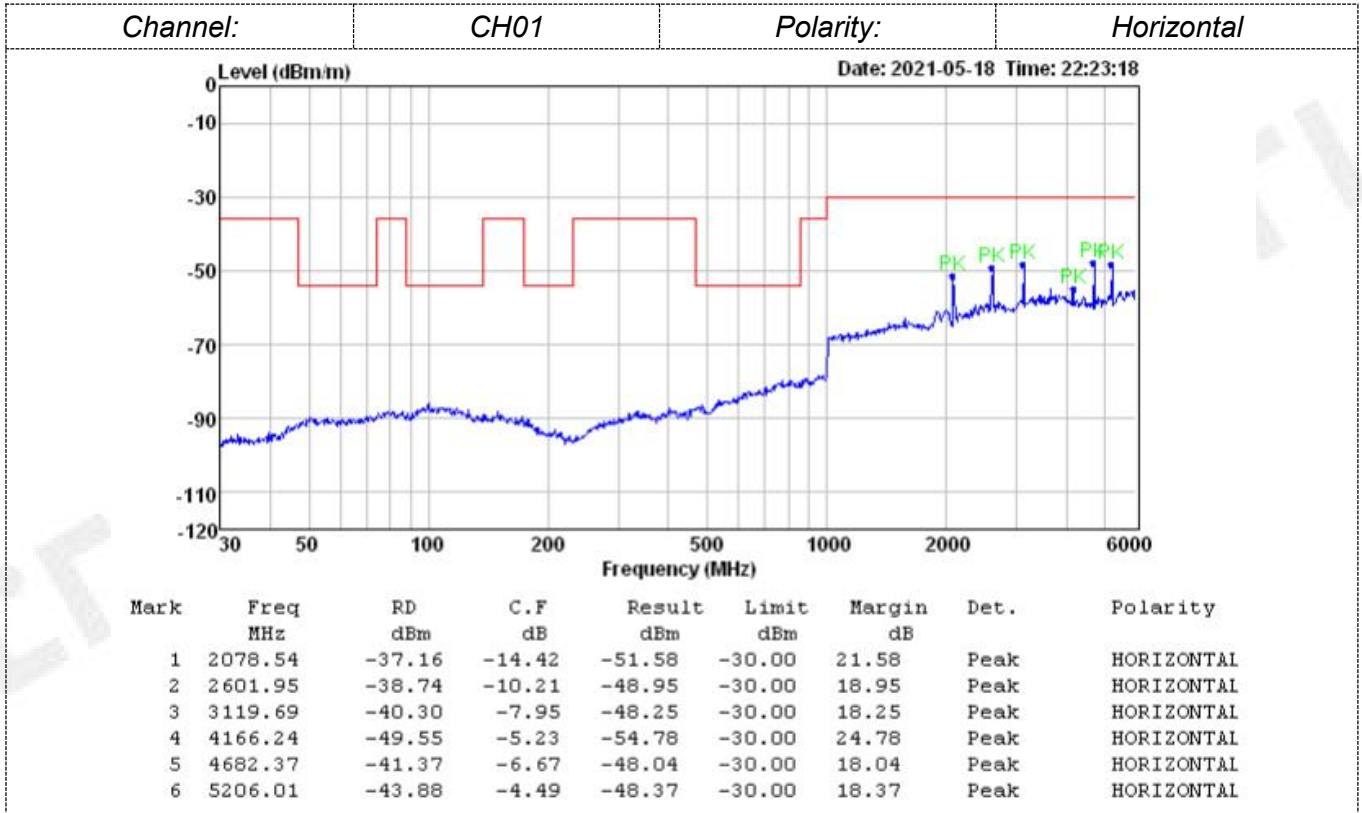

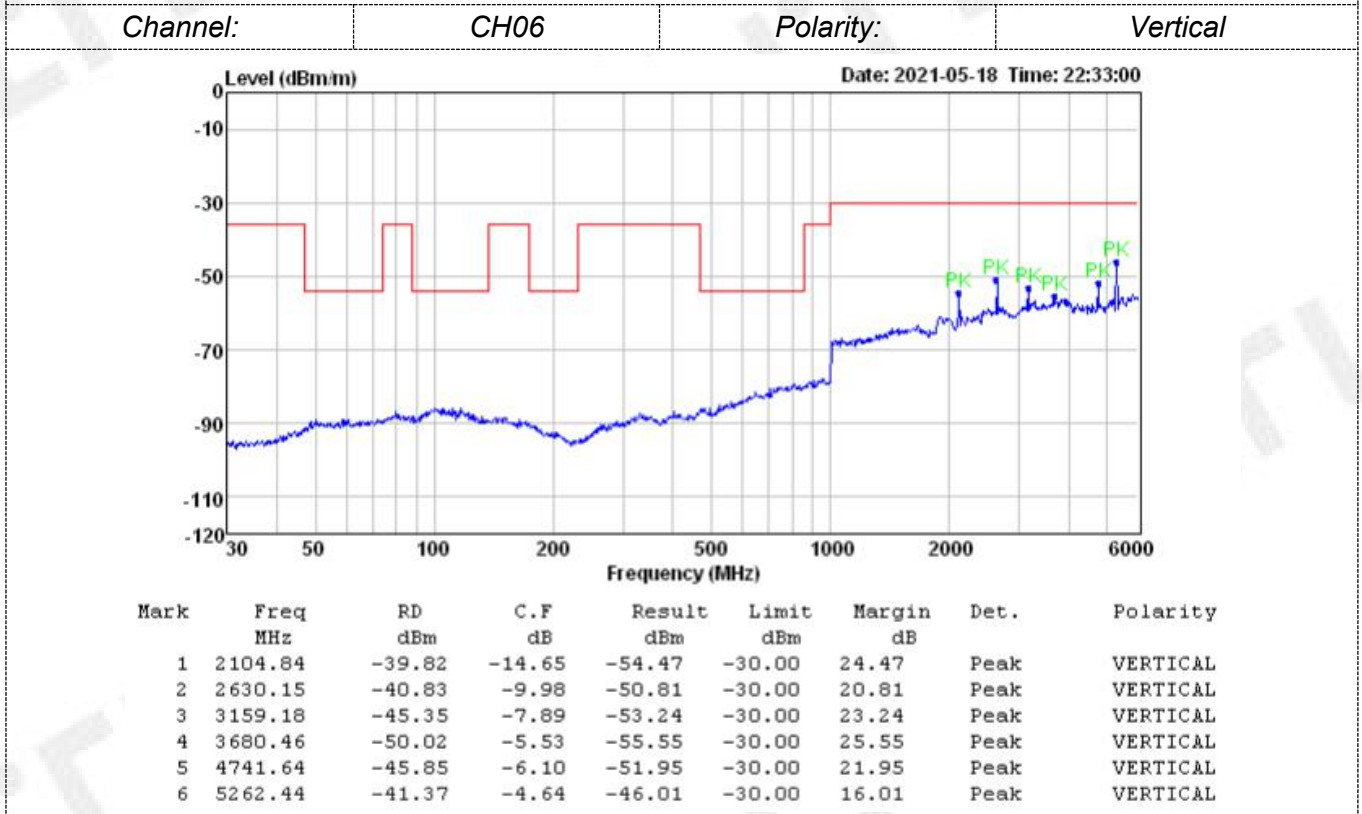
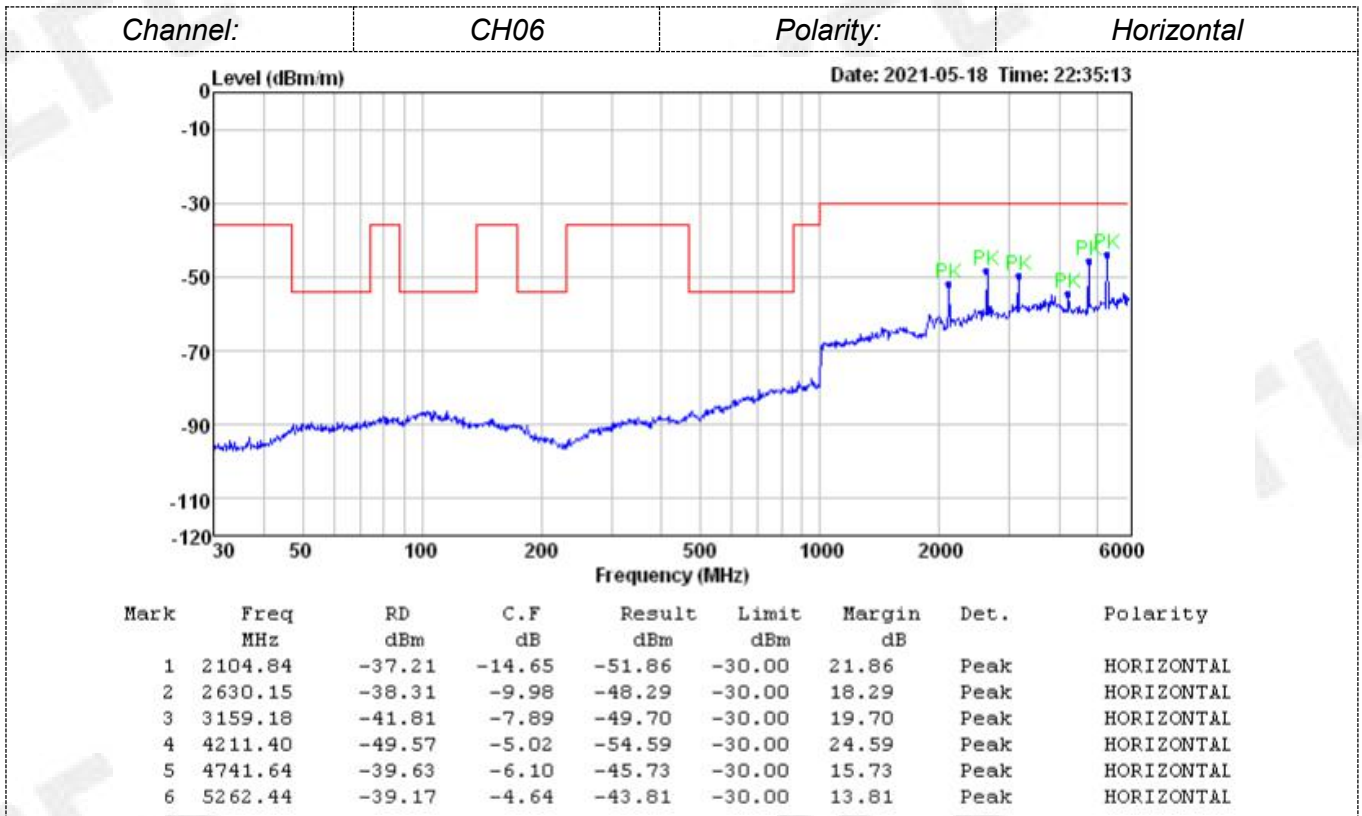

3.7. Frequency Stability

Limit

The frequency tolerance of the carrier signal shall be maintained within $\pm 0.005\%$ of the operating frequency over a temperature variation of -20 degrees to $+50$ degrees C at normal supply voltage, and for a variation in the primary supply voltage from 85% to 115% of the rated supply voltage at a temperature of 20 degrees C. Battery operated equipment shall be tested using a new battery.

Test Procedure

a) Frequency stability versus environmental temperature

1. Setup as Test Configuration for frequencies measured at ambient temperature if it is within 15°C to 25°C . Otherwise, an environmental chamber set for a temperature of 20°C shall be used.
2. Turn on EUT and set SA center frequency to the right frequency needs to be measured. Then set SA RBW to 3 kHz, VBW to 10kHz and frequency span to 500 kHz. Record this frequency to be a reference.
3. Set the temperature of chamber to 50°C . Allow sufficient time (approximately 30 min) for the temperature of the chamber to stabilize. While maintaining a constant temperature inside the chamber, turn the EUT on and measure the EUT operating frequency.
4. Repeat step 2 with a 10°C decreased per stage until the lowest temperature -20°C is measured, record all measurement frequencies.

b) Frequency stability versus input voltage

1. Setup as Test Configuration for frequencies measured at ambient temperature if it is within 15°C to 25°C . Otherwise, an environmental chamber set for a temperature of 20°C shall be used. Install new batteries in the EUT.
2. Set SA center frequency to the right frequency needs to be measured. Then set SA RBW to 3kHz, VBW to 10kHz and frequency span to 500 kHz. Record this frequency to be a reference.
3. For non hand carried, battery operated device, supply the EUT primary voltage with 85 and 115 percent of the nominal value and record the frequency.

Test Configuration

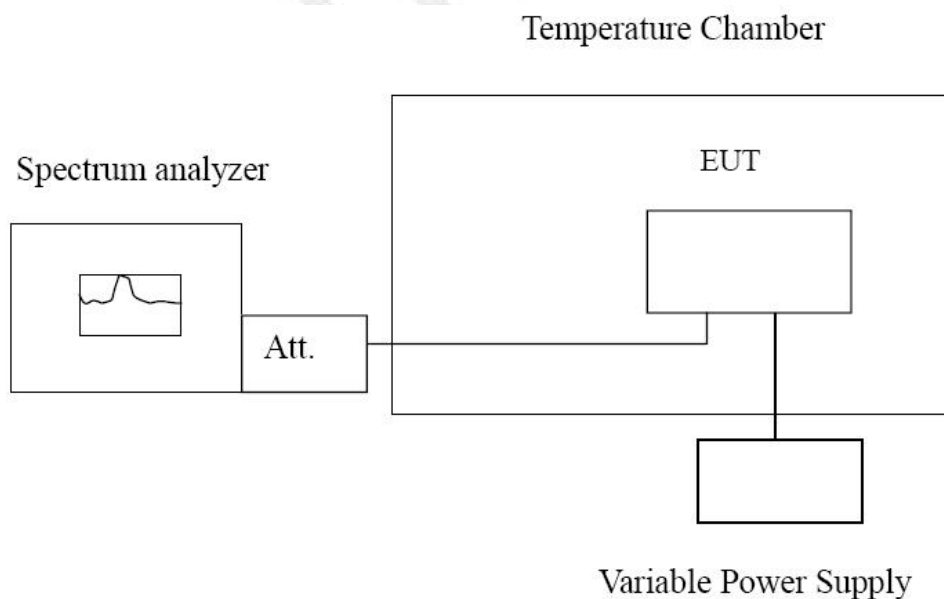

Test Results

Reference Frequency: 520.00MHz					
Voltage (V)	Temperature (°C)	Frequency error (MHz)	Frequency Tolerance (%)	Limit (%)	Result
3.7	-20	0.01815	0.00349%	±0.005	PASS
	-10	0.01842	0.00354%		
	0	0.01725	0.00332%		
	10	0.01792	0.00345%		
	20	0.01820	0.00350%		
	30	0.01762	0.00339%		
	40	0.01743	0.00335%		
	50	0.01827	0.00351%		
4.07	25	0.01910	0.00367%		
3.33	25	0.01914	0.00368%		

4. Test Setup Photos of the EUT

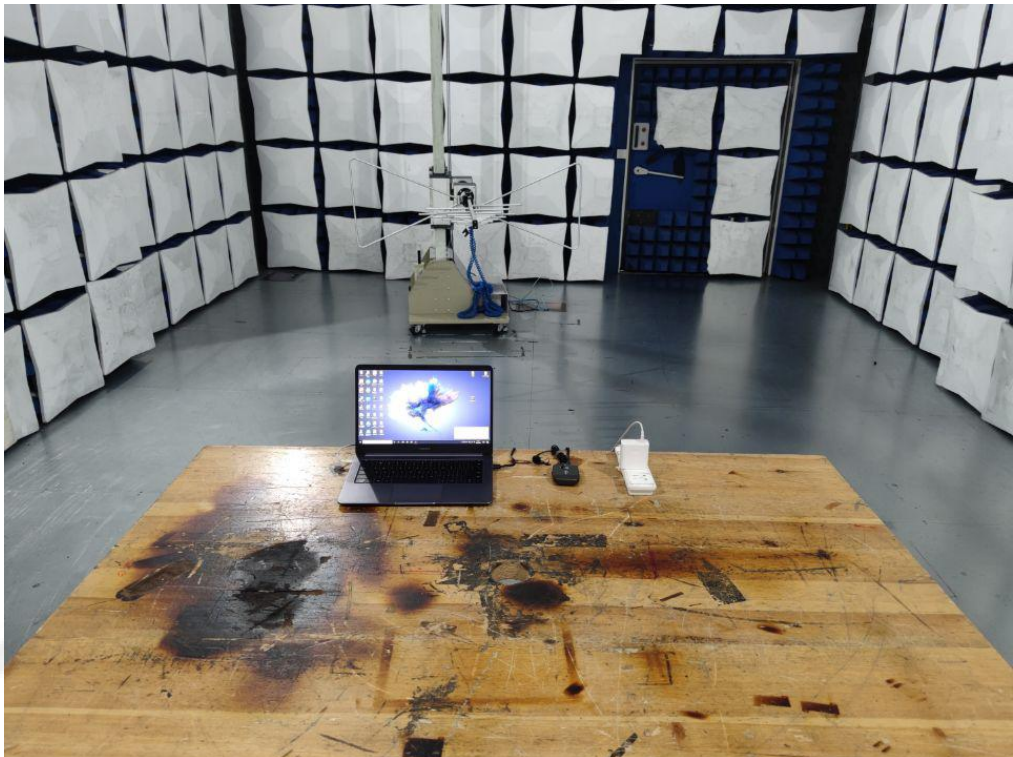
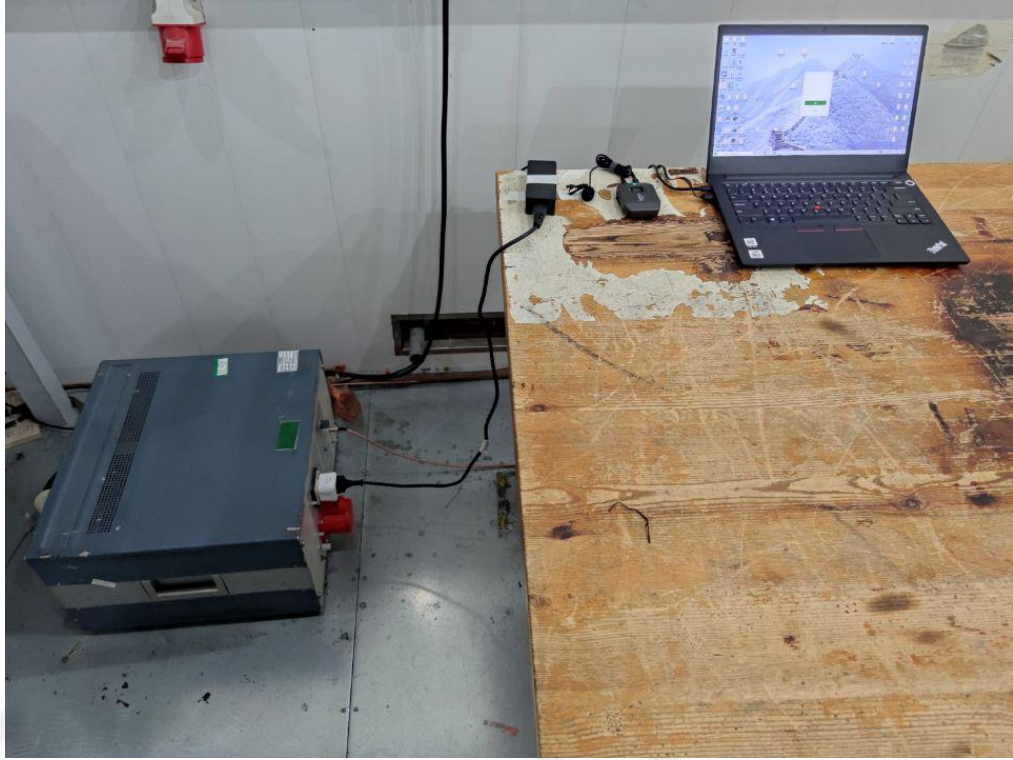

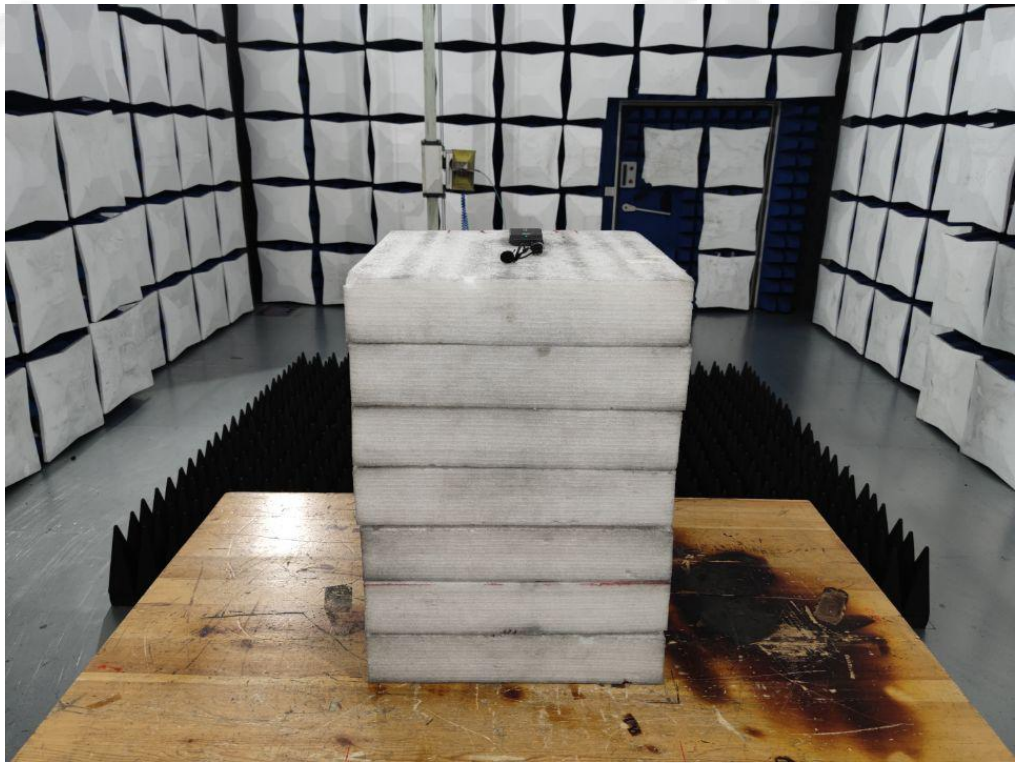

5. External and Internal Photos of the EUT

External Photos of EUT



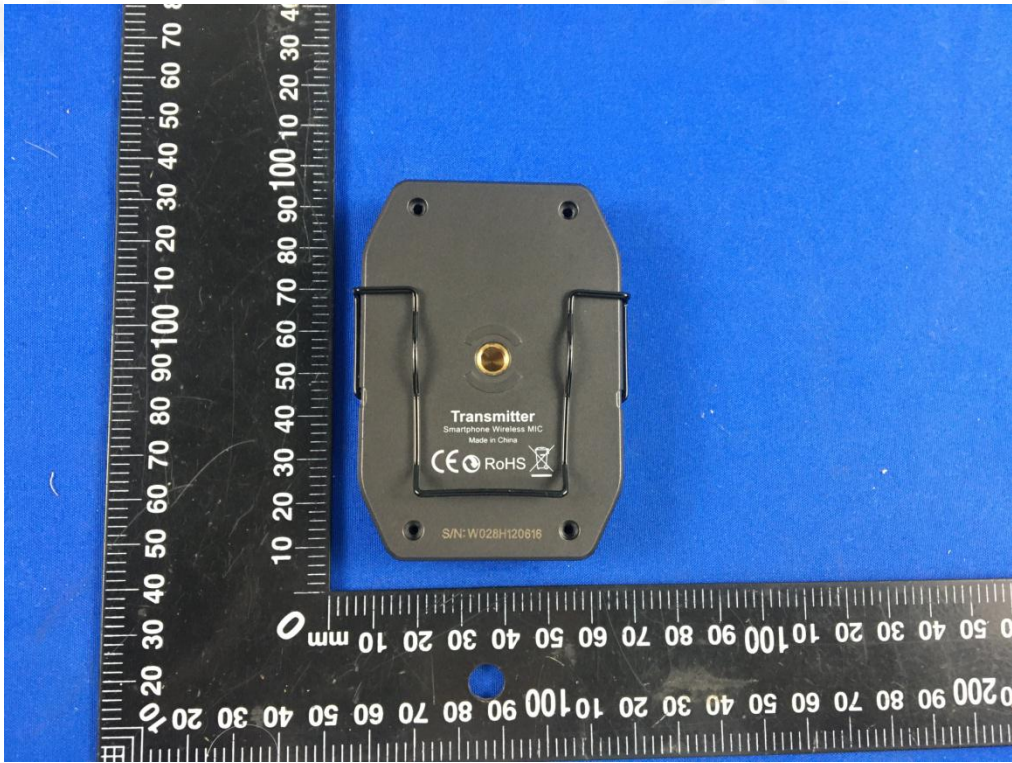





Internal Photos of EUT

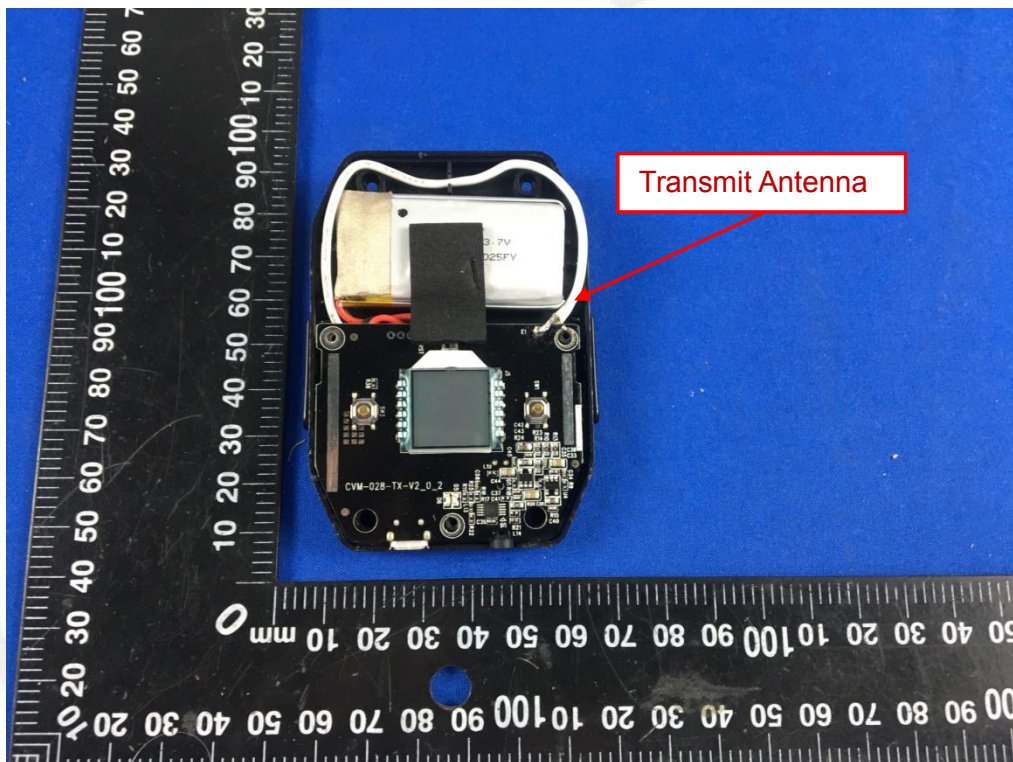
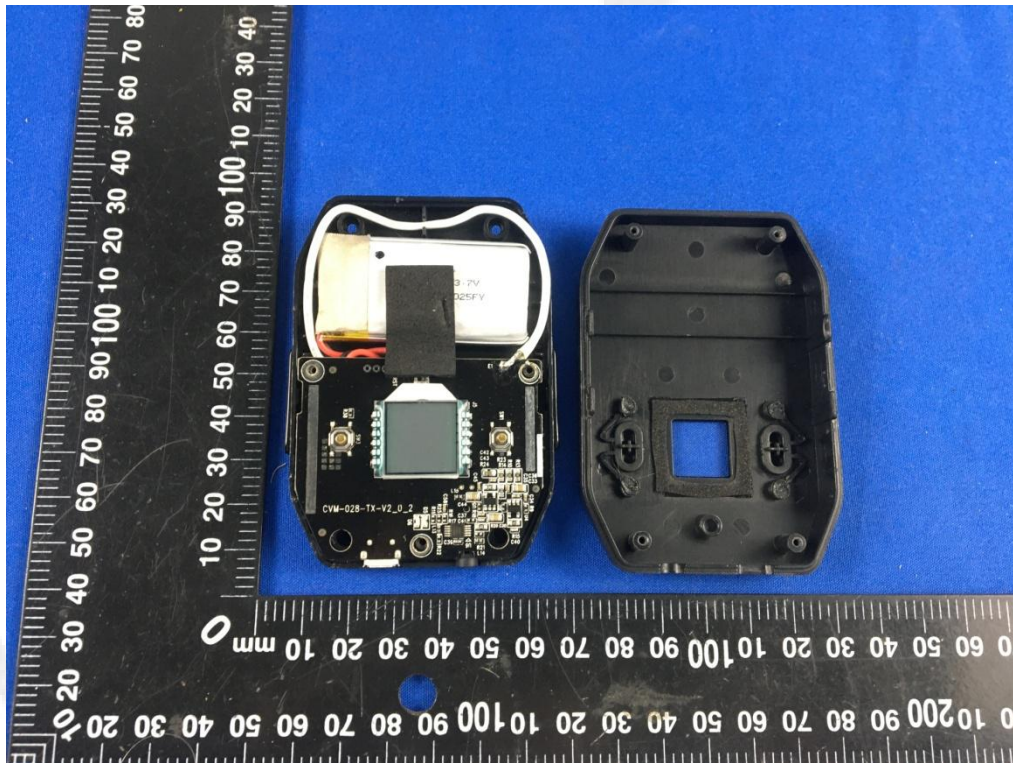

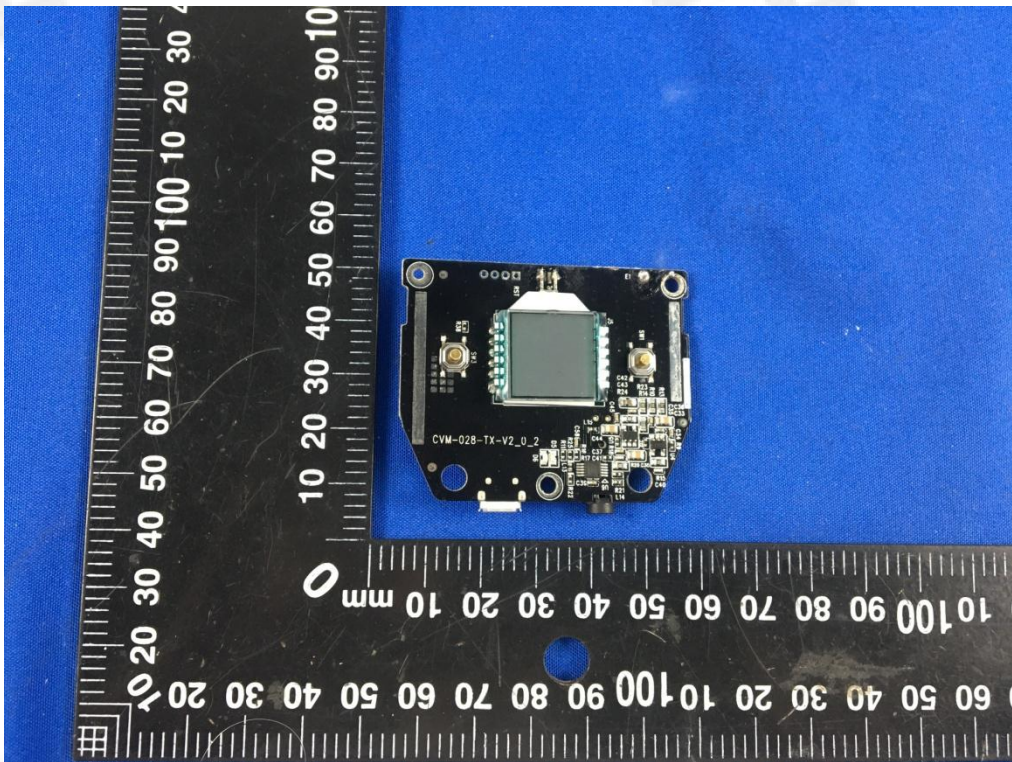
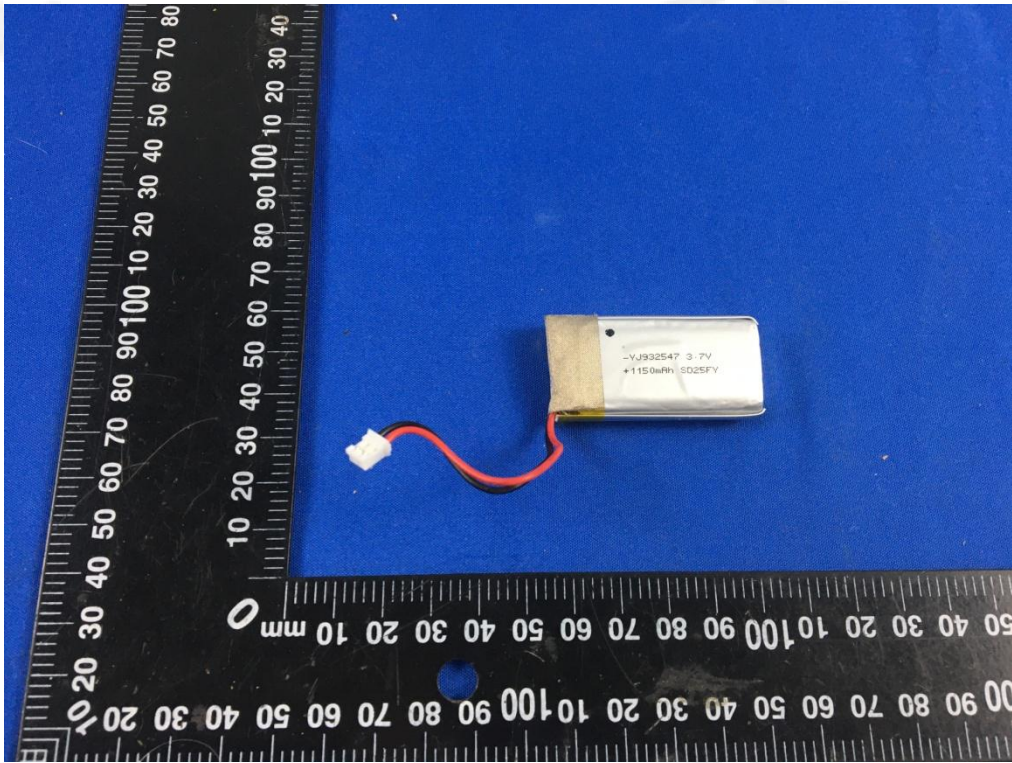

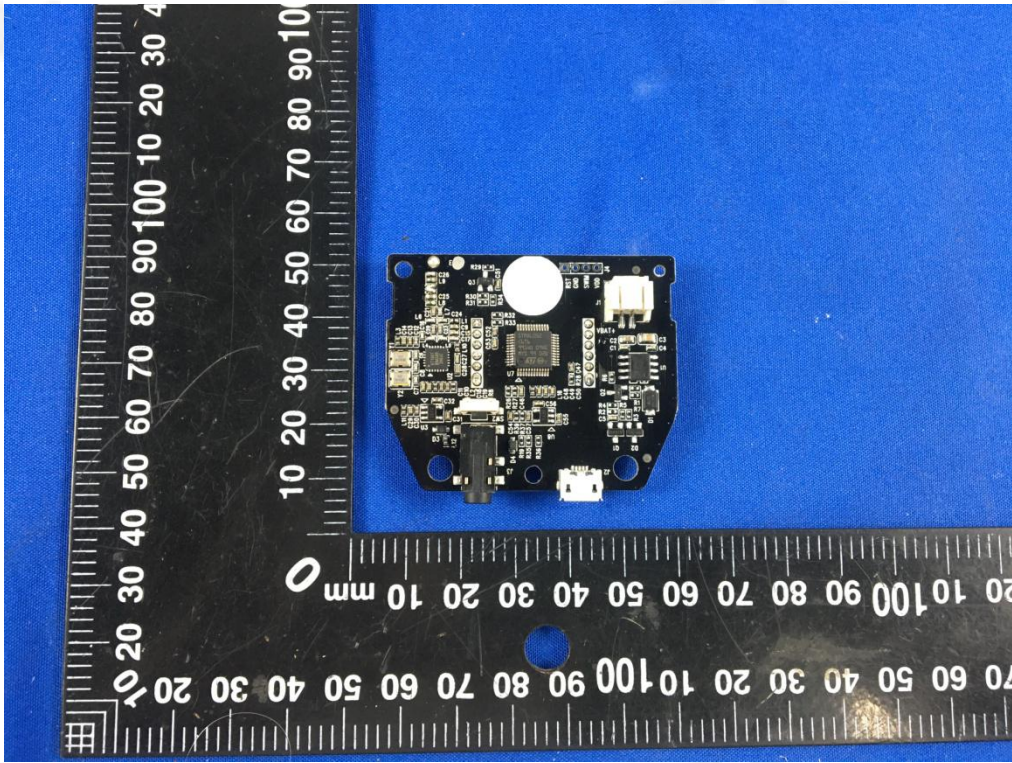

*****End of Report*****