

**LED Smart slim recessed lighting 4inch & 6inch**

MODEL ID: XTB009Y4C8001  
MODEL ID: XTB013Y4C8002

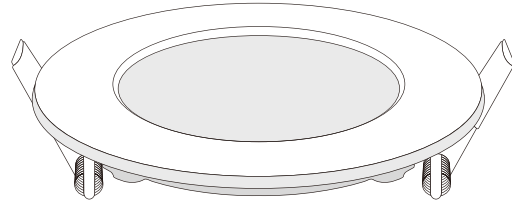

We appreciate the trust and confidence you have placed in OREIN through the purchase of recessed lighting. We strive to continually create quality products designed to enhance your home. Visit us online to see our full line of products available for your home improvement needs. Thank you for choosing OREIN. ♥

**IMPORTANT**

Read carefully before installing fixture. Retain these instructions for future reference. OREIN fixture must be wired in accordance with the National Electrical Code and all applicable local codes. Proper grounding is required for safety.

**\*THIS PRODUCT MUST BE INSTALLED IN ACCORDANCE WITH THE APPLICABLE INSTALLATION CODE BY A PERSON FAMILIAR WITH THE CONSTRUCTION AND OPERATION OF THE PRODUCT AND THE HAZARDS INVOLVED**

**\*TO PREVENT ELECTRICAL SHOCK, POWER SHOULD BE TURNED OFF AT THE FUSE BOX BEFORE INSTALLATION.**

**SAFETY WARNINGS:**

Read all product labels and directions.

**WARNING** - Risk of fire or electric shock. LED Retrofit Kit Installation requires knowledge of luminaire electrical systems. If not qualified, do not attempt installation. Contact a qualified electrician.

**WARNING** - Risk of fire or electric shock. Install this kit only in the luminaires that have the construction features and dimensions shown in the photographs and/or drawings and where the input rating of the retrofit kit does not exceed the input rating of the luminaire.

Do not make or alter any open holes in an enclosure of wiring or electrical components during kit installation. WARNING -To prevent wiring damage or abrasion, do not expose wiring to edges of sheet metal or other sharp objects.

Please examine all parts that are not intended to be replaced by the retrofit kit for damage and replace any damaged parts prior to installation of the retrofit kit. Replace only with OREIN LED. Visit our website: www.iorein.com. Call our experts at (678) 293-8382. The recessed luminaire is intended for mounting only in a covered ceiling where only the led side of the luminaire will be exposed to damp or dry or wet locations. INSTALLATION SHOULD ONLY BE PERFORMED AFTER POWER TO THE FIXTURE HAS BEEN DISCONNECTED. THIS DEVICE IS NOT INTENDED FOR USE WITH EMERGENCY EXIT. These instructions shall be included on an information sheet packaged with each unit.

**WIRING**

- 1 Cut an opening in the ceiling by using the provided template to trace the module opening (see Figure 1). The opening size (9W 4inch) is 105mm and 13W 6inch is 155mm. Make sure the opening is not larger than the outer flange of the LED module.
- 2 Open the cover of the provided j-box and insert the supply wires through the preferred strain reliefs in the provided j-box. Connect the bare copper (ground) wire from the j-box to the ground wire of the supply connection using the provided wire nut.
- 3 Connect the black/white leads from the output of the driver to the appropriate supply side wiring using the provided wire nuts.
- 4 Close the cover after properly securing the supply wire to the provided j-box on the rear of the LED module.
- 5 Module is ready to install into ceiling (See MOUNTING section for specific instructions).

**MOUNTING**

- 1 Connect the remote driver box to the light fixture. (Fig. 2)
- 2 Place remote driver box thru the cut-out hole and mount according to local code required. (Fig. 3)
- 3 Bundle any excess wire and place into ceiling above the module according to local code as required. Rotate both mousetrap springs upward to allow passage through the cutout in the ceiling (Fig.4)
- 4 Continue to press the module through the cutout in the ceiling until the perimeter flange of the module is flush against the ceiling. (Fig.5)
- 5 The springs will rotate back into position and hold the LED module tight to the ceiling. (Fig.6)

**REMOVAL**

- 1 Simply pull down firmly on LED module until mousetrap springs release from the ceiling. Reach through the ceiling to hold mousetrap springs up and away from the ceiling as you continue to pull the module from its opening.
- 2 Disconnect wiring.

**\*The models can be installed directly into a ceiling without requiring separate JBOX or recessed housings.**

**Installing support**

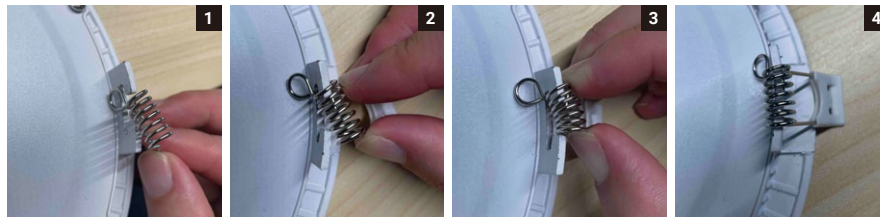

1 2  
3 4

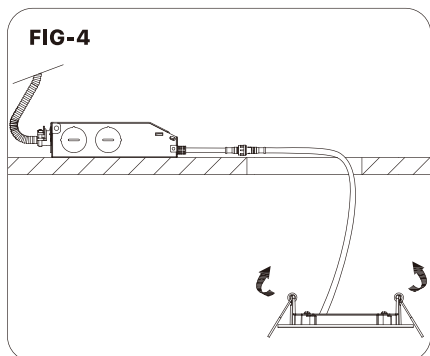
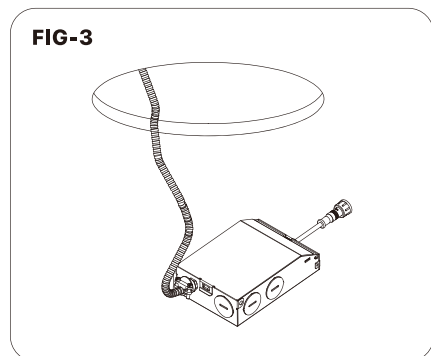
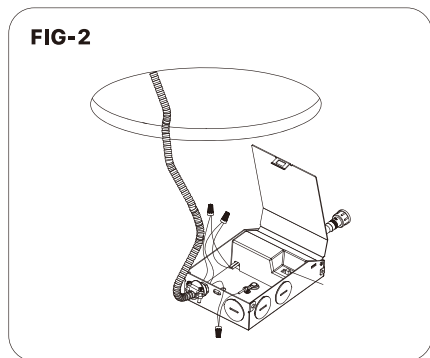
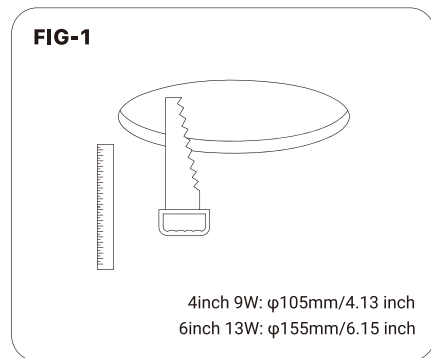

**Connect the APP**

- 1 Get the AiDot APP for Android or iOS



- 2 Create an account and sign in, enable your location and open your Bluetooth.
- 3 Press "+" button to add the light bulb.
- 4 Automatic discovery devices which to be added (through BLE protocol), then follow the instructions on App.

**Resetting Bulb**

Restore the bulb(s) to factory default by switching 6 times

- 1 Starting from wall switch OFF
- 2 User flips the wall switch off and on 5x over between 1-2 seconds
- 3 Light(s) finishes on
- 4 Light blinks twice
- 5 User connects light(s) to new network (remote) light(s) added to device list as new or after 5 min network close, restarted by wall switch. Then light(s) finishes on step 3.

**Trouble Shooting**

**Q1: Why I cannot find "AiDot" APP in Google Play Store?**

A: Please tap "search" instead for AiDot below then you'll see our APP there. Google thought you were searching for another well-known job search brand, and give priority to it to be displayed.

**Q2: Why I didn't receive the verification letter for the registration?**

A: 1, Please check if you entered a wrong email address during the registration; 2. Check if the mail was stuck in the spam folder; 3. Make sure you have registered on the app instead of the website.

**Q3: I failed to get my smart bulb connected to the network, what should I do?**

A: After ensuring the Wi-Fi of your home is 2.4G, we suggest you reset the bulb first. Turn on and off the bulb consecutively for 6 times, turn it on again. It will run a color shift. 2. Re-add the bulb on the APP. If you fail again, don't worry. It is not necessary the fault or bug on the product. There are multiple factors that can influence the connection. Please contact our technical team via the contact details shown on the app or the package. We will check it for you.

**Q4: How can I connect the bulb to Alexa?**

A: Step 1: Tap "Me" at the top left corner of Home page, select "Settings-Third-Party Services", Alexa & Hey Google", Select "Amazon Alexa".  
Step 2: Tap "Sign in with Alexa", follow the on-screen instructions to link your account. When it says "AiDot with Amazon Alexa successfully", it means the connection is done. Note: If you already have an Alexa APP account but have not signed in Alexa APP, tap "Sign in with Alexa", it will take you to the sign-in page of Alexa APP.  
Step 3: If Alexa does not successfully add your AiDot devices (which must have been already added in AiDot APP), you can add them by saying "Alexa, discover device".

**Q5: Why the app states "No Internet Access" when I select the WiFi of the bulb?**

A: The notification is from your phone especially some Android phone instead of our APP. That is because the WiFi of the device does not have access to the Internet, You can tap Connect to proceed. Please do not choose "Cancel".

**Q6: How can I share the light control with family members?**

A: Step 1: Tap the Home you create at home page, select "Home Management" enter home share page, Tap the home you want to share. Step 2: Select "Invite..." at the settings page. Step 3: At "Invite" page, fill in the name and E-mail of the invitee you want to add. The "Name" here works as a note, not necessarily to be the same as that used in the APP.

**FCC WARNING**

This device complies with part 15 of the FCC Rules. Operation is subject to the following two conditions: (1) this device may not cause harmful interference, and (2) this device must accept any interference received, including interference that may cause undesired operation. Any changes or modifications not expressly approved by the party responsible for compliance could void the user's authority to operate the equipment. NOTE: This equipment has been tested and found to comply with the limits for a Class B digital device, pursuant to Part 15 of the FCC Rules. These limits are designed to provide reasonable protection against harmful interference in a residential installation. This equipment generates, uses and can radiate radio frequency energy and, if not installed and used in accordance with the instructions, may cause harmful interference to radio communications.

However, there is no guarantee that interference will not occur in a particular installation. If this equipment does cause harmful interference to radio or television reception, which can be determined by turning the equipment off and on, the user is encouraged to try to correct the interference by one or more of the following measures:

- Reorient or relocate the receiving antenna.
  - Increase the separation between the equipment and receiver.
  - Connect the equipment into an outlet on a circuit different from that to which the receiver is connected.
- To maintain compliance with FCC's RF Exposure guidelines, This equipment should be installed and operated with minimum 20cm distance between the radiator and your body: Use only the supplied antenna.

**Contact us**

**SYVIO TECHNOLOGY CO., LIMITED**  
Room A, 8/F, Kwok Cheung Building, 635-637 Shanghai Street, Mong Kok, Hong Kong  
Phone: 0086-199-2547-1900  
Website: www.iorein.com  
Email: Support@iorein.com

**Follow us on social media**  
Facebook: @orein.led  
Youtube: OREIN LED

Made in China



## FCC WARNING

This device complies with part 15 of the FCC Rules. Operation is subject to the following two conditions: (1) this device may not cause harmful interference, and (2) this device must accept any interference received, including interference that may cause undesired operation.

Any changes or modifications not expressly approved by the party responsible for compliance could void the user's authority to operate the equipment.

NOTE: This equipment has been tested and found to comply with the limits for a Class B digital device, pursuant to Part 15 of the FCC Rules. These limits are designed to provide reasonable protection against harmful interference in a residential installation. This equipment generates, uses and can radiate radio frequency energy and, if not installed and used in accordance with the instructions, may cause harmful interference to radio communications.

However, there is no guarantee that interference will not occur in a particular installation.

If this equipment does cause harmful interference to radio or television reception, which can be determined by turning the equipment off and on, the user is encouraged to try to correct the interference by one or more of the following measures:

- Reorient or relocate the receiving antenna.
- Increase the separation between the equipment and receiver.
- Connect the equipment into an outlet on a circuit different from that to which the receiver is connected.
- Consult the dealer or an experienced radio/TV technician for help.

To maintain compliance with FCC's RF Exposure guidelines, This equipment should be installed and operated with minimum 20cm distance between the radiator and your body: Use only the supplied antenna.