

## Dongguan Pan Asia electronics Co., LTD

## SPECIFICATION FOR APPROVAL

客 戶:  
CUSTOMER: \_\_\_\_\_

客 戶 料 号:  
CUST P/N: \_\_\_\_\_

产 品 料 号: 0.08\*48P  
FINE P/N: \_\_\_\_\_

产 品 型 号: 6.3UH10%\43.5\*.20.5\*0.6 Slotted back glue Outlet length30mm(±2mm)  
DESC: \_\_\_\_\_

日 期: 2023/07/26  
DATE: \_\_\_\_\_

版 本:  
Version: \_\_\_\_\_

制作 PREPARED BY	审核 CHECKED BY	批准 APPROVED BY	客户承认 CUSTOMER APPROVE



# SPECIFICATION

產品型號:

客戶 CUST:

331

DESC

Φ43.5x20.5-10Ts-0.08x48P-30mm

版本

料号 Fine P/N:

FYD331003

Rev: A.0

客戶料号 CUST P/N:

A11

一、尺寸 DIMENSION:(mm)

A 40±0.5

B 20±0.5

C 0.6

D1 32mm±2

D2 30mm±2

二、原理图 SCHEMATIC DIAGRAM:



三、绕线参数 Winding Specification:

F 43.6±0.2

G 8.0 ref

H 1.3±1

I 5.3 ref

E 3±0.2

注:

- 1.线圈贴磁片, 磁片尺寸 43.5±0.2mm.,厚度为0.6
- 2.线圈出线位置缠8mm(ref)宽度高温胶纸 1-2Ts;
- 3.磁片反面贴圆形直径 42mm(ref)白色双面胶,内孔 20.5/8.6mm (ref), (必须加带孔 3mm双面胶)。

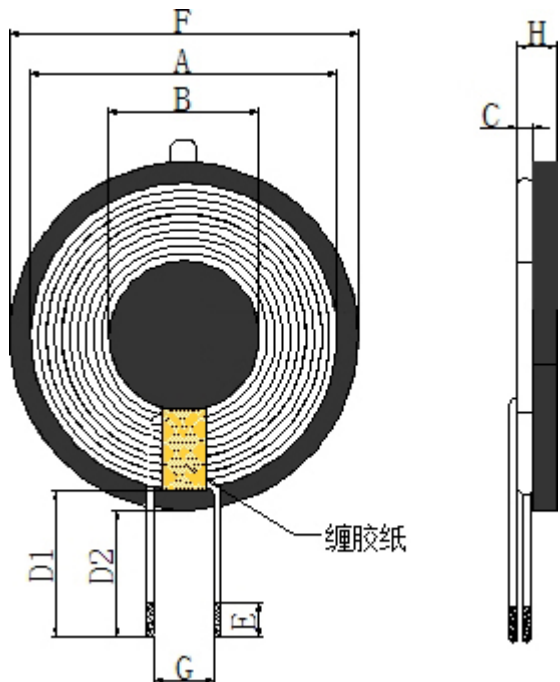

序号 NO.	端子 TERMINAL		线径 WIRE	圈数 Turns	绕线方向 Winding Direction
1	S	F	0.08*48P	10Ts	CCW

四、电气特性 ELECTRICAL CHARACTERISTICS:

温度 TEMPERATURE:25±10°C, 湿度 RELATIVE HUMIDITY:75±20%

序号 NO.	项目 ITEM	端子 TERMINAL	标准 SPECIFICATION	测试条件 TEST FREQUENCY	测试仪器 TEST EQUIPMENTS
1	IND.	S-F	5.4uH ±15%单独线圈	100KHz/1.0V	LCZ METER 1062B
2	IND.	S-F	6.5uH ±15%加磁片	100KHz/1.0V	LCZ METER 1062B
3	DCR	S-F	≤50mΩ		LCZ METER 502B

擬制/日期 PREPARED BY/DATE

審核/日期 CHECKED BY/DATE

2023/7/26

2023/7/26