

承认书

SPECIFICATION FOR APPROVEAL

客户名称(CUSTOMER): BLS TN064

客户料号(PART NO.): BLS0-F19.5×27.5-65-FR

品名(DESCRIPTION):

规格(SPECIFICATION): 19.5x27.5,0.08×105P, 65MM

日期 DATE: 20230804

本司确认 (TRX APPROVAL)		
制作	审核	承认日期
曾小仙	邱志辉	20230804
客户确认 (CUSTOMER APPROVAL)		
工程	批准	承认日期
确认结果(Result):	<input type="checkbox"/> 合格	<input type="checkbox"/> 不合格 <input type="checkbox"/> 其它

东莞市德弗力五金电子材料有限公司

Dongguan city DFL Electronic Technology Co.,LTD

Address: No. 107, Xinfeng West Road, Shijie Town, Dongguan City

东莞市德弗力五金电子材料有限公司

Dongguan city DFL Electronic Technology Co.,LTD

SPECIFICATION

产品型号: DESC	BLS0-F19.5×27.5-65-FR	版本 Rev:A	Customer:	BLS TN064
			Description:	双线圈+磁片
			Date:	20230804

一、尺寸DIMENSION:(mm)

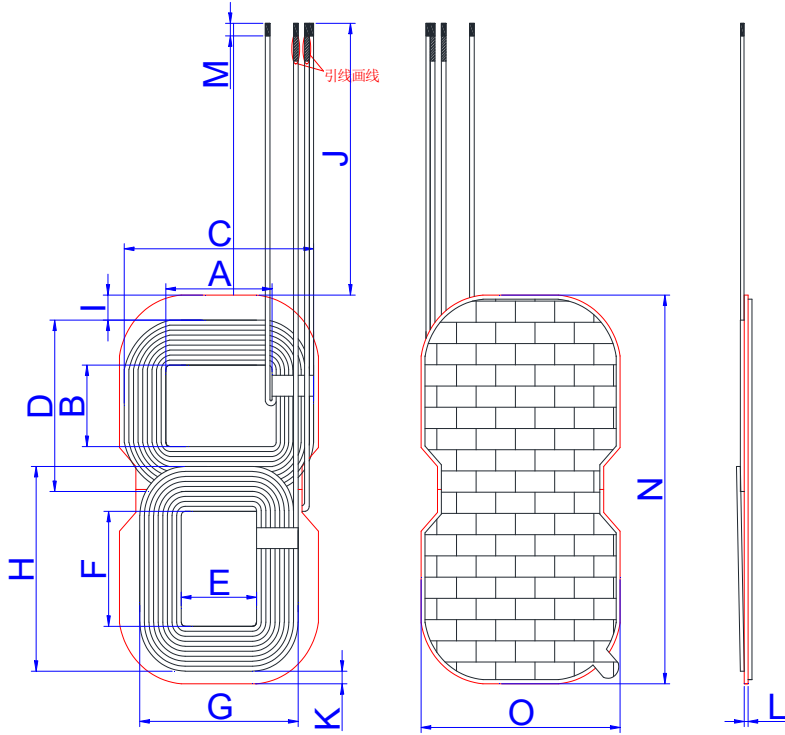

A	27.5±1.0
B	19.5±1.0
C	49.0±1.5
D	41.0±1.5
E	19.5±1.0
F	27.5±1.0
G	41.0±1.5
H	48.0±1.5
I	6.0±1.0
J	65.0±5.0
K	3.0±1.0
L	1.0±0.2
M	3.0±2.0
N	93.0±1.0
O	51.5±1.0
P	

注:

- 1.线圈贴51.5*93*1.0双拼硬磁
- 2.线圈出线位置缠5MM高温胶带
- 3.磁片贴白色带耳朵双面胶
- 4.上线圈距磁片6.0MM, 下线圈距磁片3.0MM
- 5.下线圈引线画线
- 6.线圈不可松线

二、原理图 (schematic diagram:)

三、绕线参数(Winding Specification:)

序号 NO.	端子 TERMINAL	线径 WIRE	圈数 Turns	绕线方向 Winding Direction
1		0.08×105P丝包线	9TS	上逆时针下顺时针

四、电气特性 ELECTRICAL CHARACTERISTICS:

温度 TEMPERATURE:25±10°C,湿度 RELATIVE HUMIDITY:65±20%

序号 NO.	项目 ITEM	端子 TERMINAL	标准 SPECIFICATION	测试条件 TEST FREQUENCY	测试仪器 TEST EQUIPMENTS
1	IND.		7.1uH±10%加磁片	100KHz/1.0V	SHDA 1062
2	IND.				
3	Q值				
4	DCR				

拟制/日期PREPARED BY/DATE	审核/日期CHECKED BY/DATE	客户/日期CUSTOMER/DATE