

TONOR

UHF Wireless Microphone Instruction Manual

TW520

UK
CA

CE

FC

RoHS



ABOUT THIS MANUAL

Thank you for purchasing TONOR wireless microphone. This manual is intended to help you understand all about this microphone and how to use it. TONOR always strives for the ultimate user experience. All our knowledge and passion for audio technology are incorporated into building microphones with high performance for you. The TONOR microphone is high quality and easy to use to achieve the best user experience.

Enjoy your microphone!

TONOR Team

Package Including

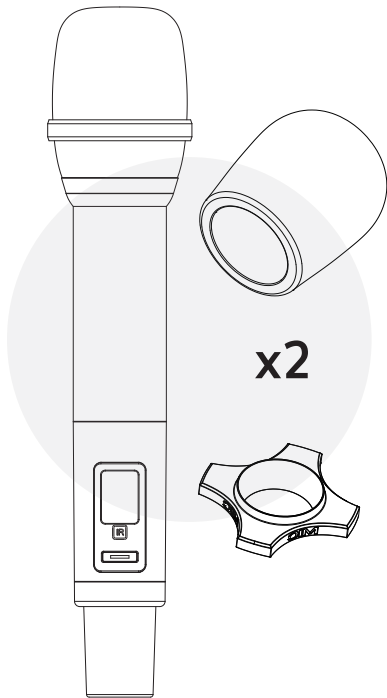

OPERATING ENVIRONMENTS & NOTES

- When using this device, keep it away from water.
- Use the device in ventilated environment, keep it away from fire.
- Since it's a wireless device, please keep it away from other interfering sources.
- Don't take apart the device.
- Please use the standard power supply, high voltage may damage the device.
- When the battery is low, the mic or receiver will automatically shut down. Please charge it.
- Recommended to use the original charging cable for all charging equipment. Or use a Type-A to Type-C charging cable.
- Not recommended to use equipment while charging.

SPECIFICATIONS

1. Frequency range: 539.5-578.5MHz
2. Channels: 20ch/each channel
3. RF power: 10dBm
4. Frequency response: 40Hz-18kHz
5. T.H.D: $\leq 0.5\%$
6. Mic Battery: Lithium battery 14650 3.7V/1100mAh
7. Mic Charging Time: 3-4 hours
8. Mic Battery Life: 10 hours
9. Receiver powered: DC 13.5V, 1000mA
10. Working distance: Up to 80m

MICROPHONE OPERATION INSTRUCTION

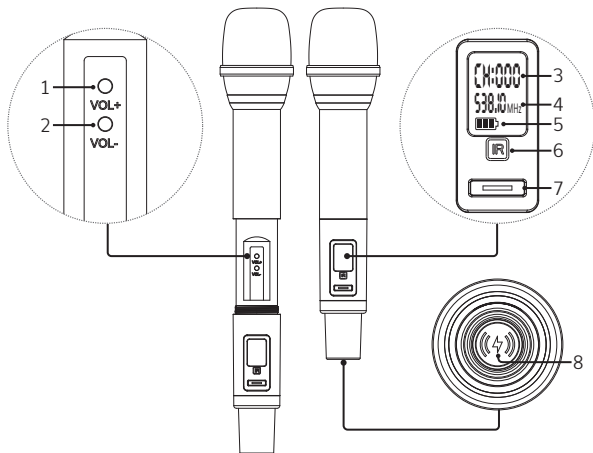

1. Volume +

- When adjusting the volume, the screen will display from U00 to U16.

2. Volume -

- When adjusting the volume, the screen will display from U00 to U16.

- Note that when the volume is adjusted to U00, it will return to U12 for hearing protection next time it is turned on.

3. Frequency Number

- CHA from CH001 to CH020. CHB from CH101 to CH120.

4. Current Frequency

5. Microphone real-time battery level

6. IR Infrared Pairing Window

7. Power Switch with LED Indicator

- Press and hold for two seconds to turn on and off the microphone.

- The power indicator light is always green when the mic is turned on.

8. Wireless Charging Point

STEPS TO PAIR

1. Turn on the microphone and receiver.
2. Recommended Automatic setting: Press and hold the set button for 2 seconds for CHA to automatically search for the best frequency. When the receiver selects the frequency, align the microphone IR window with the receiver IR window within 20cm. Click the set button, and wait for 3 seconds. When the frequencies of the microphone and receiver are consistent, pairing is successful. If unsuccessful, click the set button again and wait 3 seconds to pair again.
3. Optional Manual setting: Click receiver up button 5 or down button 7 to choose the free frequency needed for CHA. Align the CHA IR window with the receiver IR window for CHA within 20cm. Click set button for CHA to pair. When the frequencies of the microphone and receiver are consistent, pairing is successful. If unsuccessful, click the set button again and wait 3 seconds to pair again.
4. Repeat 2 or 3 step for others to finish pairing for CHB.
5. The pairing steps of CHB are the same as CHA. When operating CHB, just follow the buttons on CHB.
6. Multiple sets used together:
 - Make sure all devices are turned off. Then turn on the first set of receivers and pair CHA and CHB according to step 2. Keep the paired microphone and receiver turned on.
 - Later turn on the second set of receivers and repeat step 2, and so on. Please keep paired devices turned on until all devices are paired. It is recommended that up to 6-7 sets be used at the same time.

TROUBLESHOOTING

- ▷ Turn on all the microphones, but one of them has on sound.
- ▶ Reconnect the microphone and receiver according to the STEPS TO PAIR.

- ▷ Received signal with noise or interference
- ▶ Change to other frequencies.
- ▶ Check whether the receiving distance exceeds the maximum range.

- ▷ Microphone cannot be tuned on.
- ▶ Check whether microphone is full charged.

EU Declaration of conformity

• RoHS Directive (2011/65/EU)

Hereby, Fujian EastWest Lifewit Technology Co.,LTD declares that the radio equipment type TW520 is in compliance with Directive 2014/53/EU.

The full text of the EU declaration of conformity is available at the following internet address:

<https://www.tonormic.com/pages/eu-declaration-of-conformity>

Conditions and restrictions for using frequencies

Conditions and restrictions for using frequencies

There may be special conditions and restrictions for using frequencies in your country.

Before putting the product into operation, find the information for your country at the following address:

<https://www.tonormic.com/pages/permitted-frequency-bands>

WARRANTY

TONOR provides 2 years of after-sales service, free replacement to products that are NOT damaged resulting from accident, alteration, misuse, negligence, or abuse. If exceeding 30 days of Amazon return policy, you can still contact us through our Shopify TONOR-MIC. We will serve you with full sincerity!

FCC Statement

US **MX**

This device complies with part 15 of the FCC Rules. Operation is subject to the following two conditions:

- (1) This device may not cause harmful interference.
- (2) This device must accept any interference received, including interference that may cause undesired operation.

ISED Statement

CA

This device contains licence-exempt transmitter(s)/receiver(s) that comply with Innovation, Science and Economic Development Canada's licence-exempt RSS(s). Operation is subject to the following two conditions:

- (1) This device may not cause interference.
- (2) This device must accept any interference, including interference that may cause undesired operation of the device.

FR

L'émetteur/récepteur exempt de licence contenu dans le présent appareil est conforme aux CNR d'Innovation, Sciences et Développement économique Canada applicables aux appareils radio exempts de licence. L'exploitation est autorisée aux deux conditions suivantes:

- (1) L'appareil ne doit pas produire de brouillage;
- (2) L'appareil doit accepter tout brouillage radioélectrique subi, même si le brouillage est susceptible d'en compromettre le fonctionnement.

NOTE: This equipment has been tested and found to comply with the limits for a Class B digital device, pursuant to part 15 of the FCC Rules. These limits are designed to provide reasonable protection against harmful interference in a residential installation. This equipment generates uses and can radiate radio frequency energy and, if not installed and used in accordance with the instructions, may cause harmful interference to radio communications. However, there is no guarantee that interference will not occur in a particular installation. If this equipment does cause harmful interference to radio or television reception, which can be determined by turning the equipment off and on, the user is encouraged to try to correct the interference by one or more of the following measures:

- Reorient or relocate the receiving antenna.
- Increase the separation between the equipment and receiver.
- Connect the equipment into an outlet on a circuit different from that to which the receiver is connected.
- Consult the dealer or an experienced radio/TV technician for help.

FCC Radiation Exposure Statement

The device has been evaluated to meet general RF exposure requirement. The device can be used in portable exposure condition without restriction.

ISED Radiation Exposure Statement

The device has been evaluated to meet general RF exposure requirement. The device can be used installed and operated with minimum distance 0mm between the radiator and your body.

L'appareil a été évalué pour répondre aux exigences générales d'exposition aux RF. Cet équipement doit être installé et utilisé avec une distance minimale de 0 mm entre le radiateur et votre corps.

This device operates on a no-interference, no-protection basis. Should the user seek to obtain protection from other radio services operating in the same TV bands, a radio licence is required. For further details, consult Innovation, Science and Economic Development Canada's Client Procedures Circular CPC-2-1-28, Voluntary Licensing of Licence-Exempt Wireless Microphones in the TV Bands.

Operating Frequency

CHA/20CH							
CH001	539.5	CH006	544.5	CH011	549.5	CH016	554.5
CH002	540.5	CH007	545.5	CH012	550.5	CH017	555.5
CH003	541.5	CH008	546.5	CH013	551.5	CH018	556.5
CH004	542.5	CH009	547.5	CH014	552.5	CH019	557.5
CH005	543.5	CH010	548.5	CH015	553.5	CH020	558.5

CHB/20CH							
CH101	559.5	CH106	564.5	CH111	569.5	CH116	574.5
CH102	560.5	CH107	565.5	CH112	570.5	CH117	575.5
CH103	561.5	CH108	566.5	CH113	571.5	CH118	576.5
CH104	562.5	CH109	567.5	CH114	572.5	CH119	577.5
CH105	563.5	CH110	568.5	CH115	573.5	CH120	578.5

	AT	BE	BG	CY	CZ	DE
	DK	EE	EL	ES	FI	FR
	HR	HU	IE	IT	LT	LU
	LV	MT	NL	PL	PT	RO
	SE	SI	SK	UK(NI)		

 <https://www.tonormic.com>

 support@tonormic.com



Vous êtes responsable de remettre tous les appareils électriques et électroniques usagés à des points de collecte correspondants.

Pour en savoir plus:
www.quefairedemesdechets.fr



FR

Les piles et batteries se recyclent

À DÉPOSER EN MAGASIN À DÉPOSER EN DÉCHÈTTERIE

OU



Points de collecte sur www.quefairedemesdechets.fr

FUJIAN EASTWEST LIFEWIT TECHNOLOGY CO.,LTD | RM
1201-1205, BLD 18, 2ND PHASE OF INNOVATION PARK, FUZHOU
350108, CHINA

EASTWEST ELECTRONIC COMMERCE CO US LIMITED | 3500
SOUTH DUPONT HIGHWAY, SUITE G106 DOVER, DE 19901 UNITED
STATES

LIFEWIT LIMITED | UNIT 2, VINCENT HOUSE, FIRCROFT WAY,
EDENBRIDGE UNITED KINGDOM

Lifewit GmbH | Friedenstraße 5 97072 Wuerzburg Germany

MADE IN CHINA