

10. RF Conducted Spurious Emissions

10.1. Block diagram of test setup

Same as 4.1.

10.2. Limits

In any 100 kHz bandwidth outside the frequency bands in which the spread spectrum intentional radiator is operating, the radio frequency power that is produced by the intentional radiator shall be at least 20 dB below that in the 100 kHz bandwidth within the band that contains the highest level of the desired power.

10.3. Test procedure

(1) Connect EUT's antenna output to spectrum analyzer by RF cable.

(2) Establish a reference level by using the following procedure:

Center frequency	Test frequency
RBW:	100 kHz
VBW:	300 kHz
Span	Wide enough to capture the peak level of the in-band emission
Detector Mode:	Peak
Sweep time:	auto
Trace mode	Max hold

(3) Allow the trace to stabilize, use the peak marker function to determine the maximum peak power level to establish the reference level.

(4) Set the spectrum analyzer as follows:

RBW:	100 kHz
VBW:	300 kHz
Span	Encompass frequency range to be measured
Number of measurement points	$\geq \text{span}/\text{RBW}$
Detector Mode:	Peak
Sweep time:	auto
Trace mode	Max hold

(5) Allow the trace to stabilize, use the peak marker function to determine the maximum amplitude of all unwanted emissions outside of the authorized frequency band

10.4. Test result

EUT Set Mode	Channel or Frequency	Result (dBm)	EUT Set Mode	Channel or Frequency	Result (dBm)
11b	CH1	Pass	11g	CH1	Pass
	CH6	Pass		CH6	Pass
	CH11	Pass		CH11	Pass
11n HT 20	CH1	Pass	11n HT 40	CH3	Pass
	CH6	Pass		CH6	Pass
	CH11	Pass		CH9	Pass

10.5. Test graphs

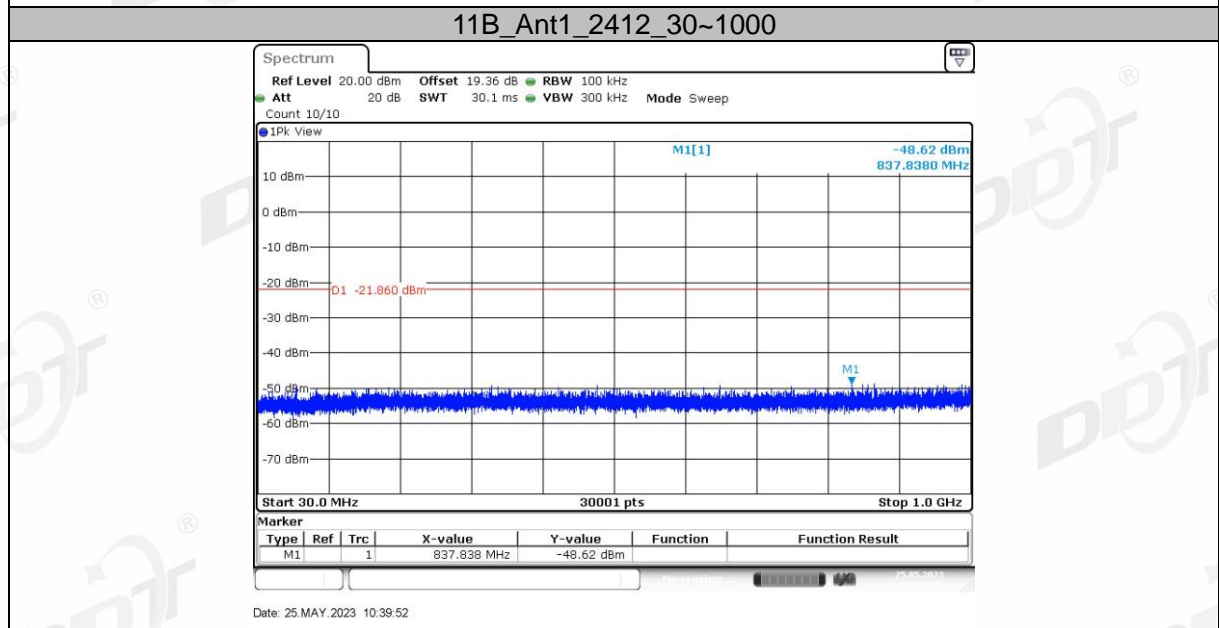
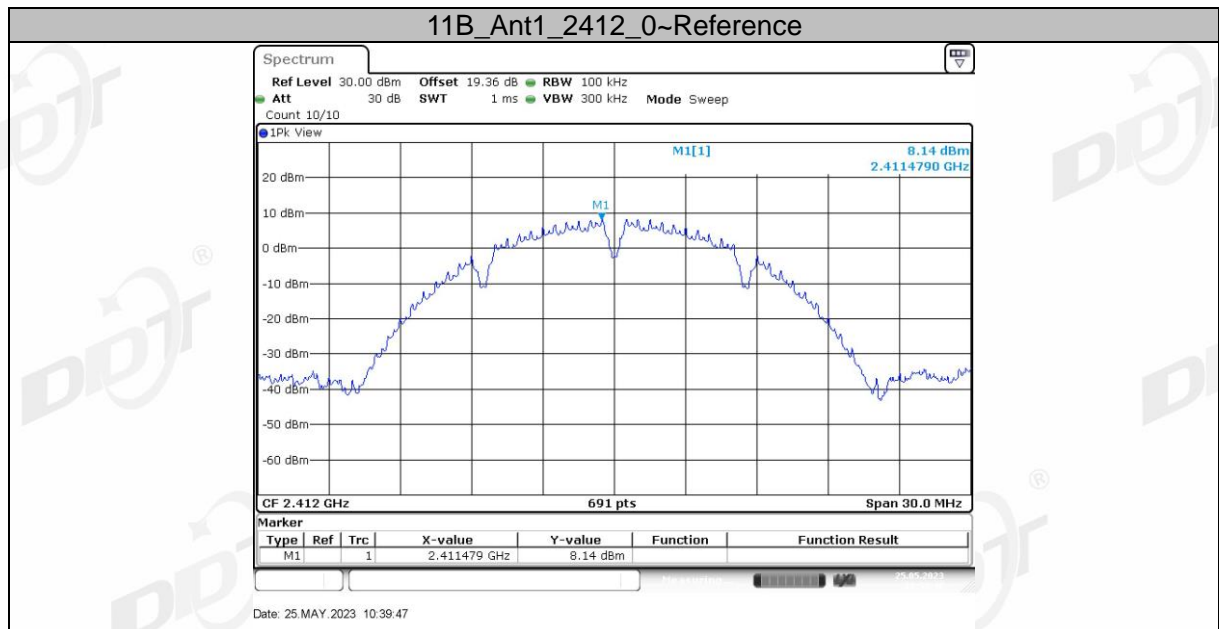

11B_Ant1_2412_1000~26500

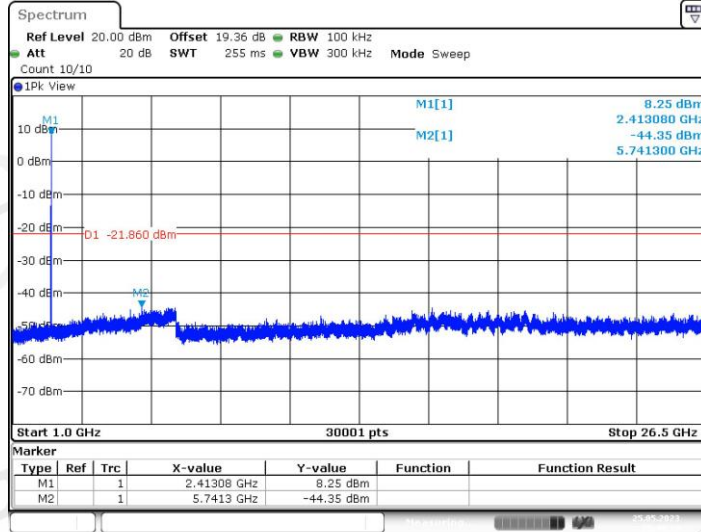

Date: 25.MAY.2023 10:40:14

11B_Ant2_2412_0~Reference

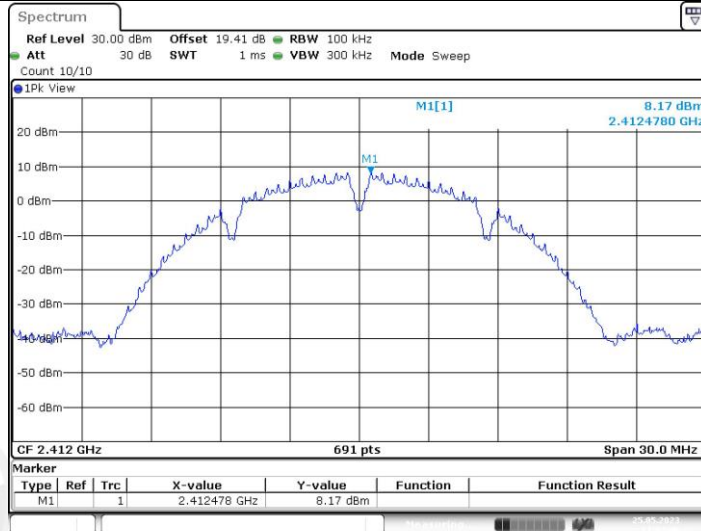

Date: 25.MAY.2023 11:02:40

11B_Ant2_2412_30~1000

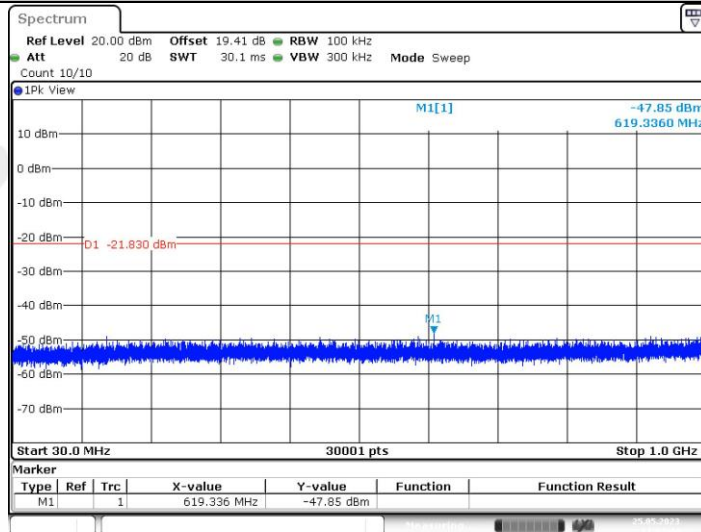

Date: 25.MAY.2023 11:02:44

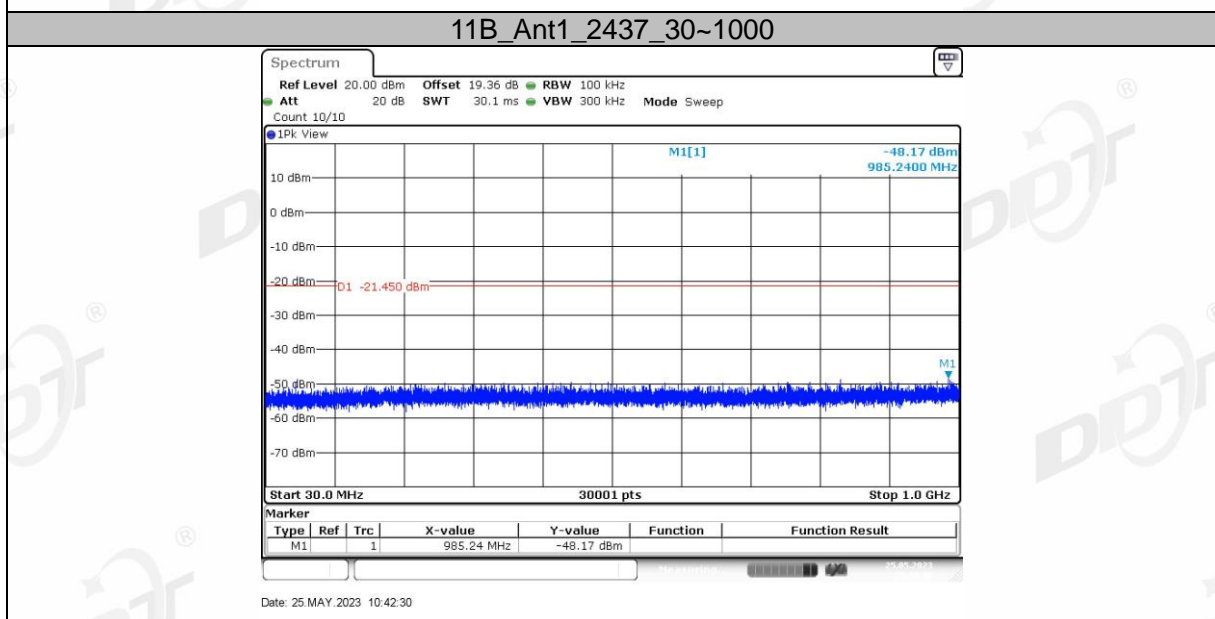
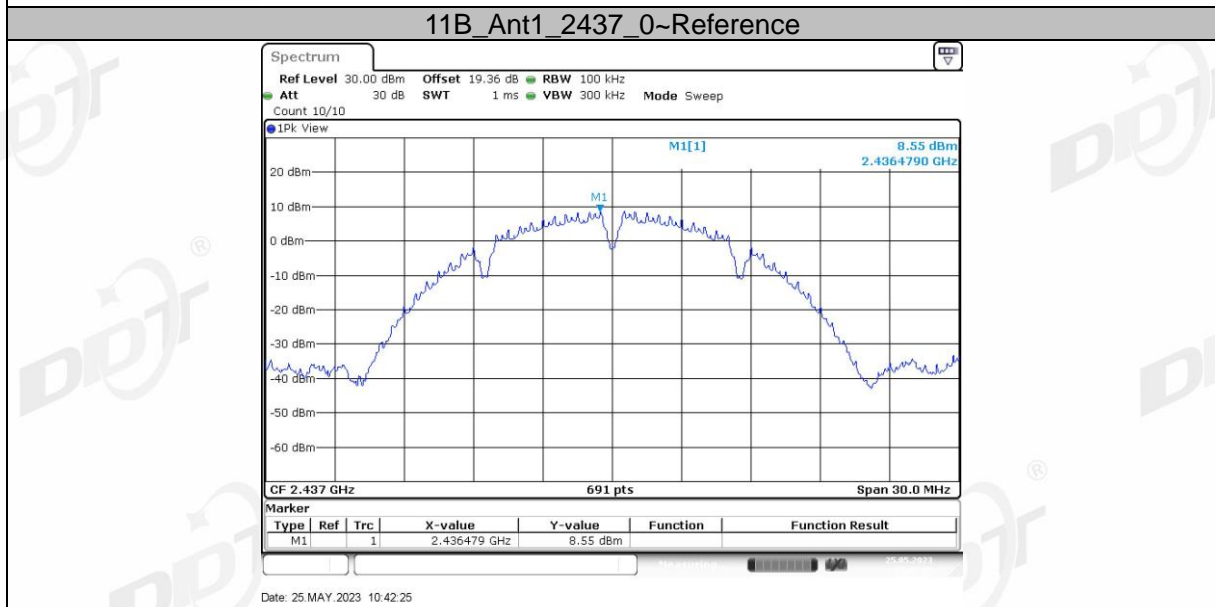
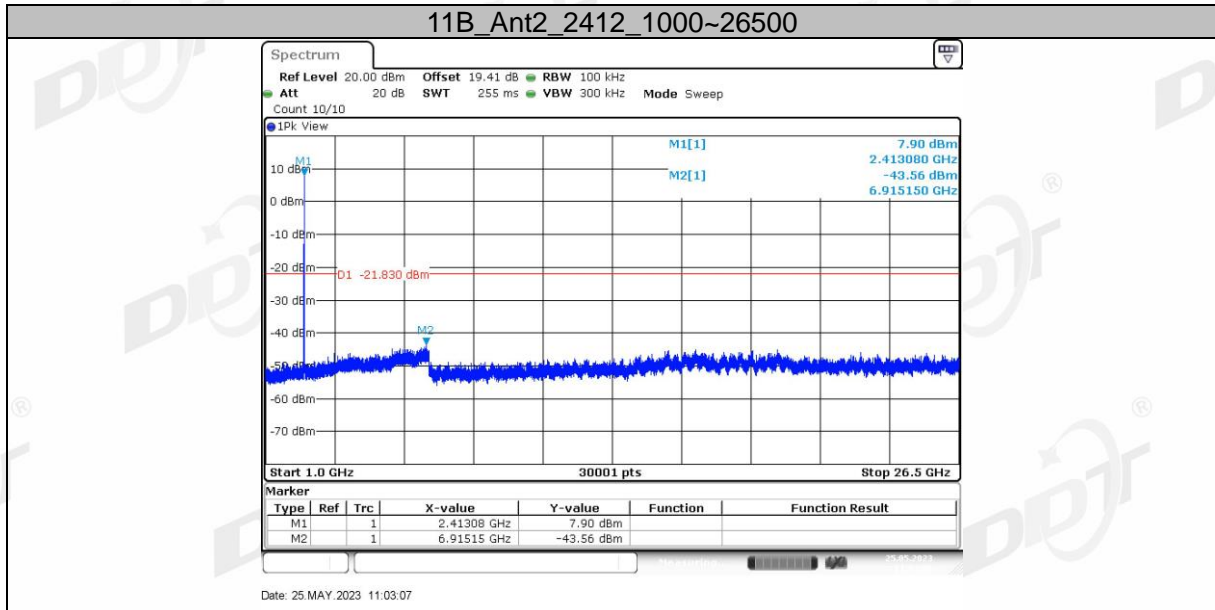

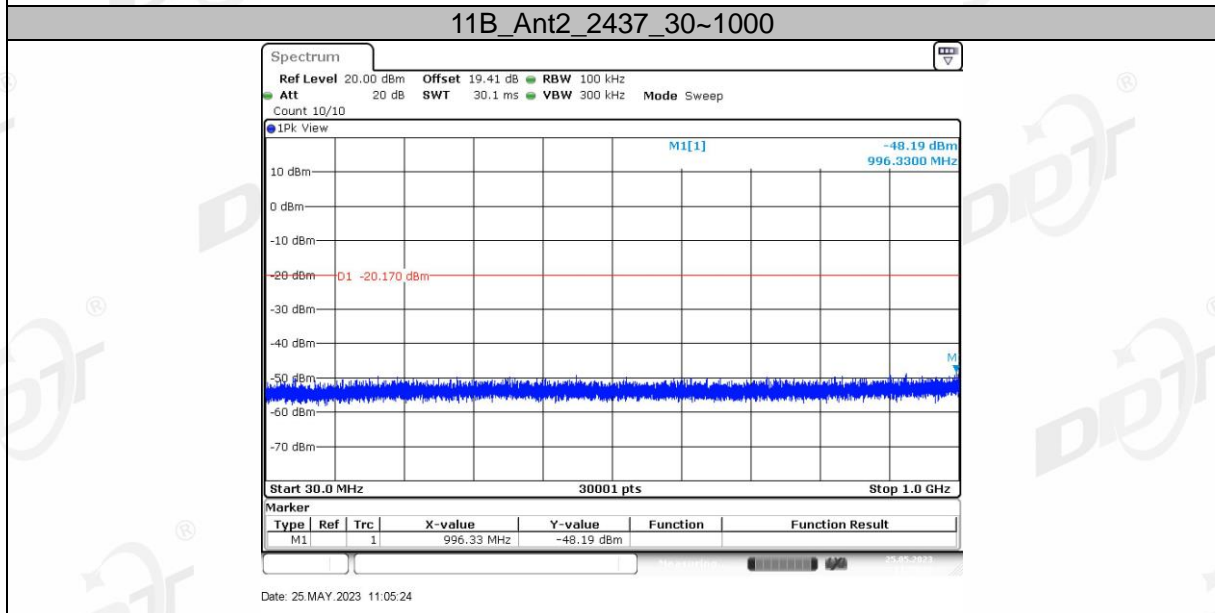
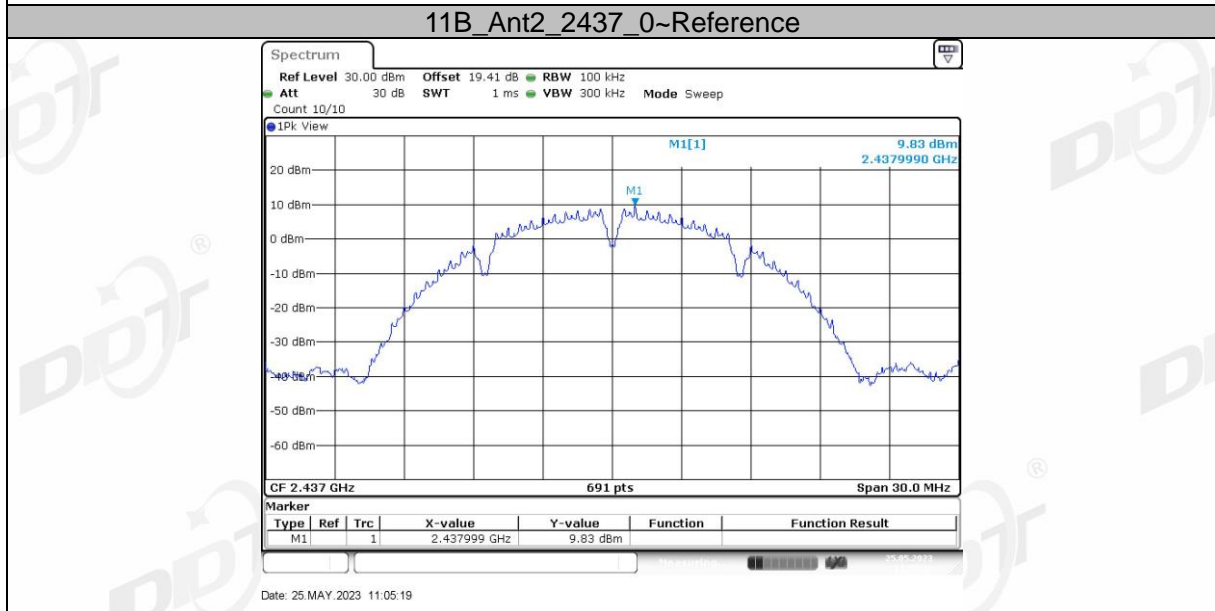
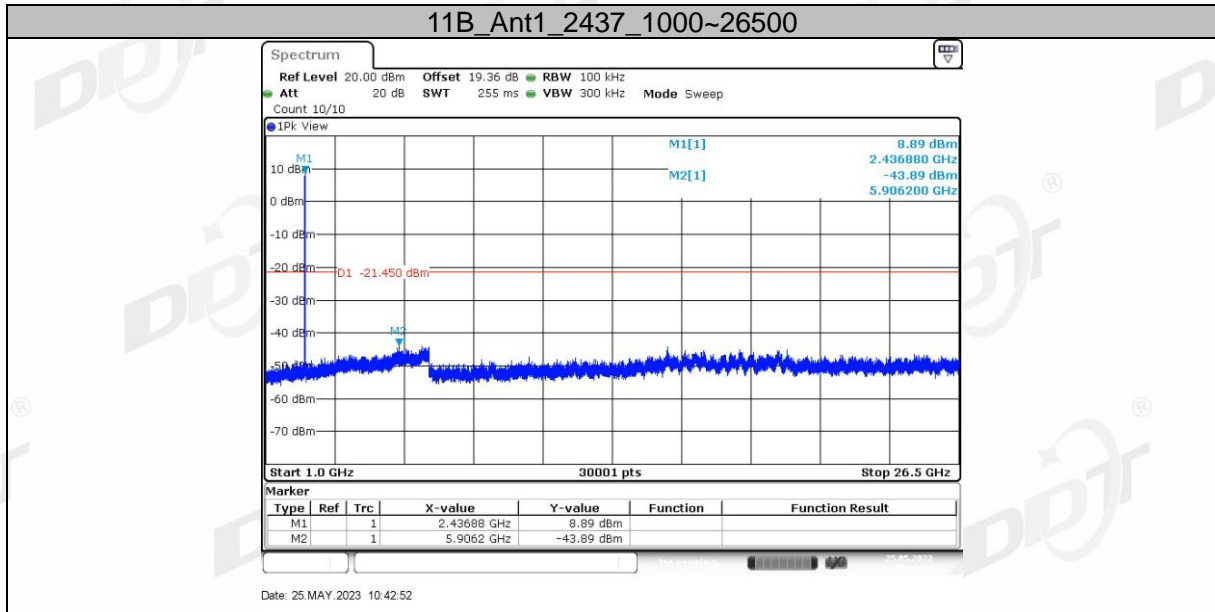

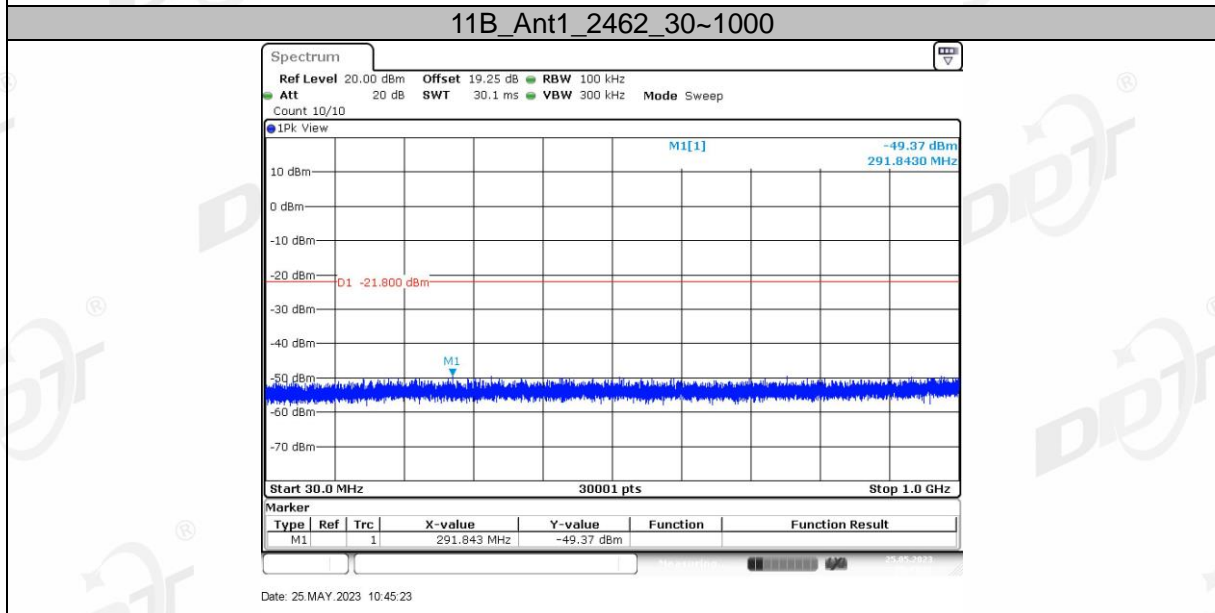
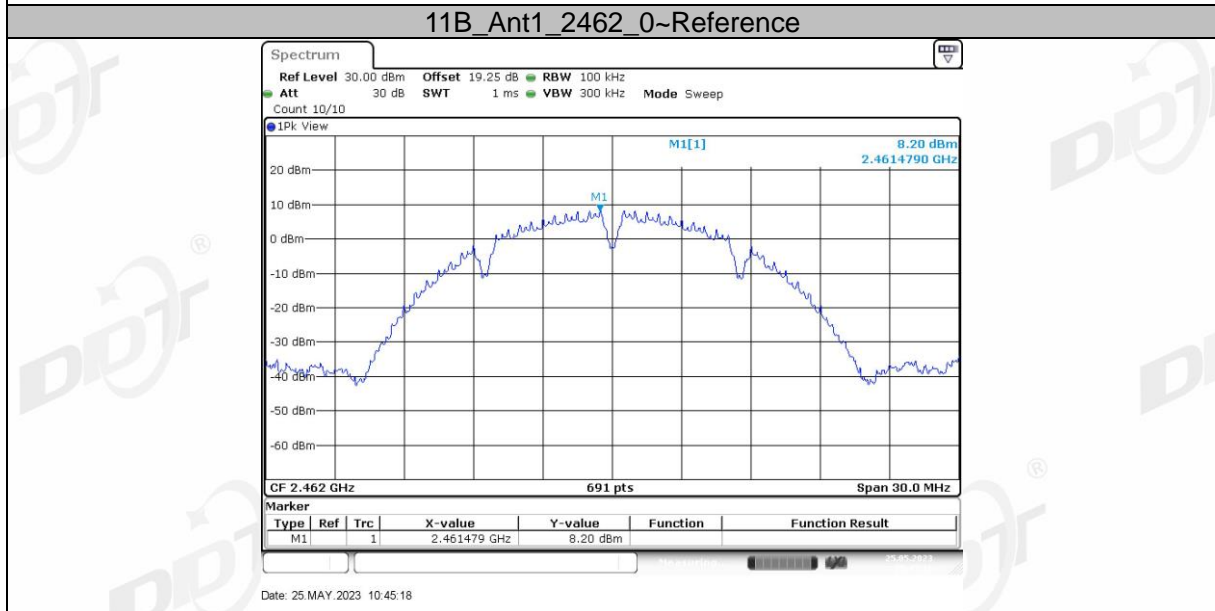
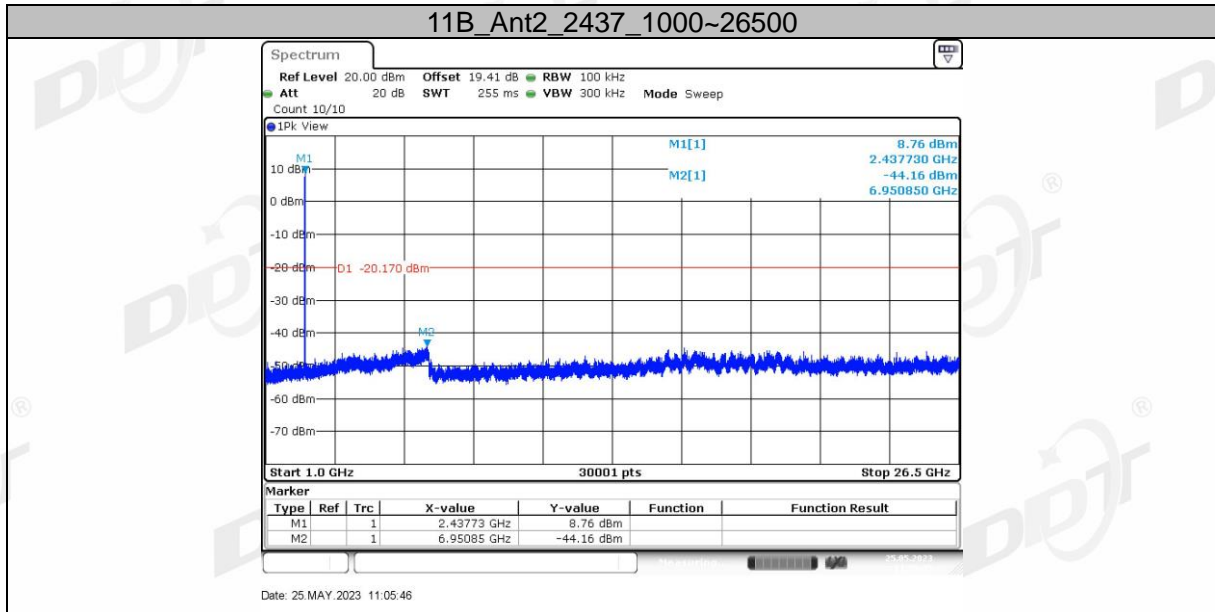

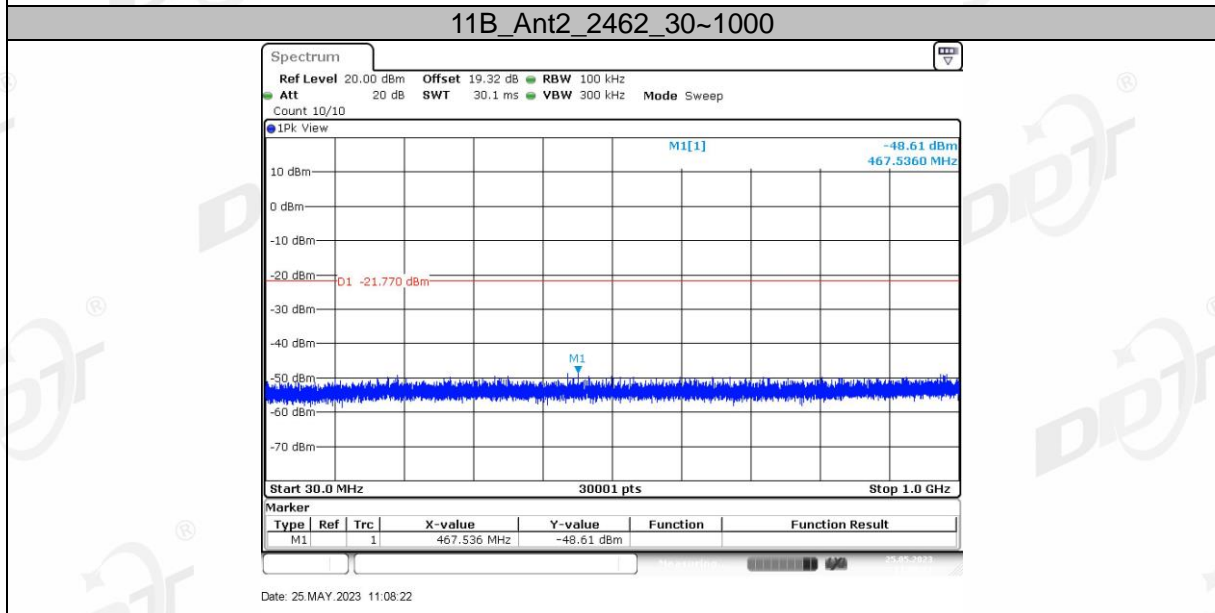
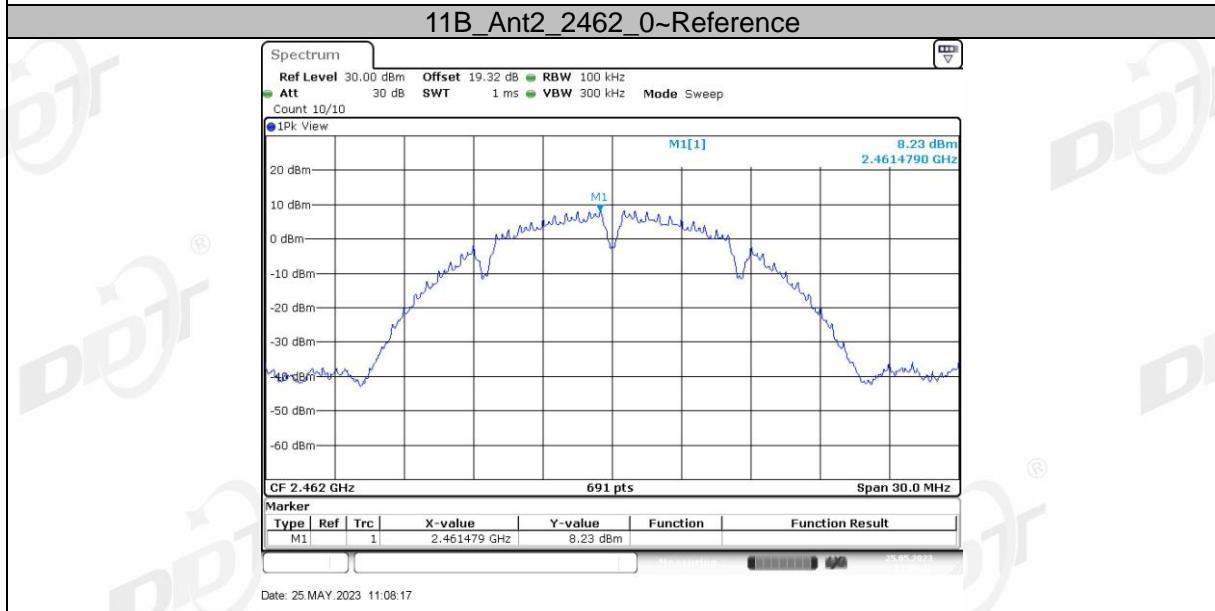
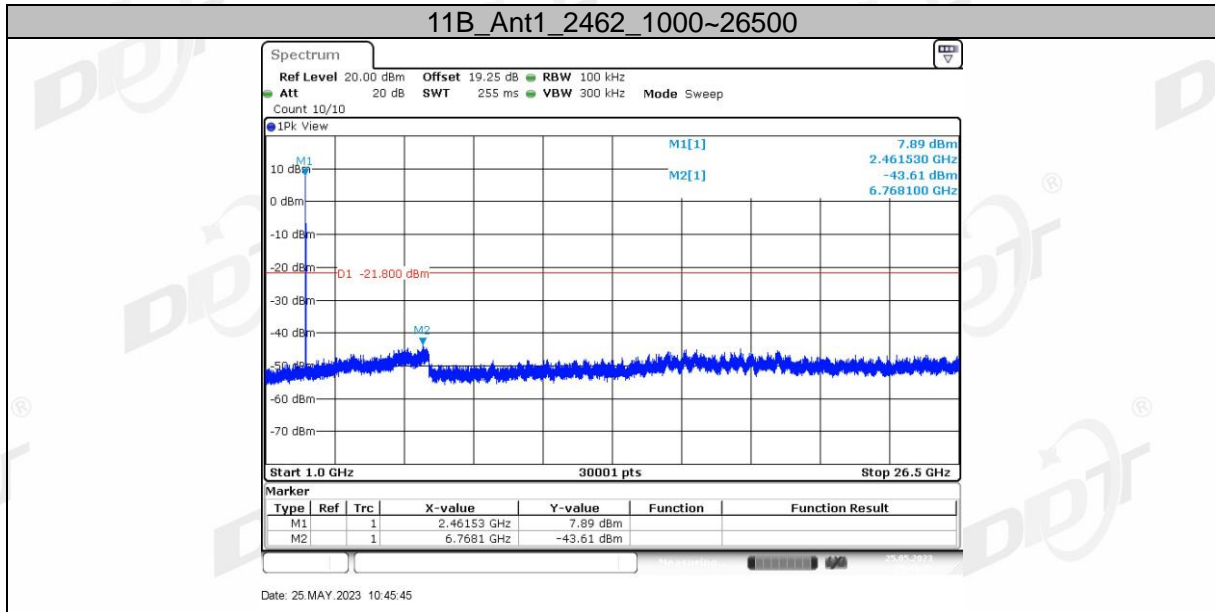

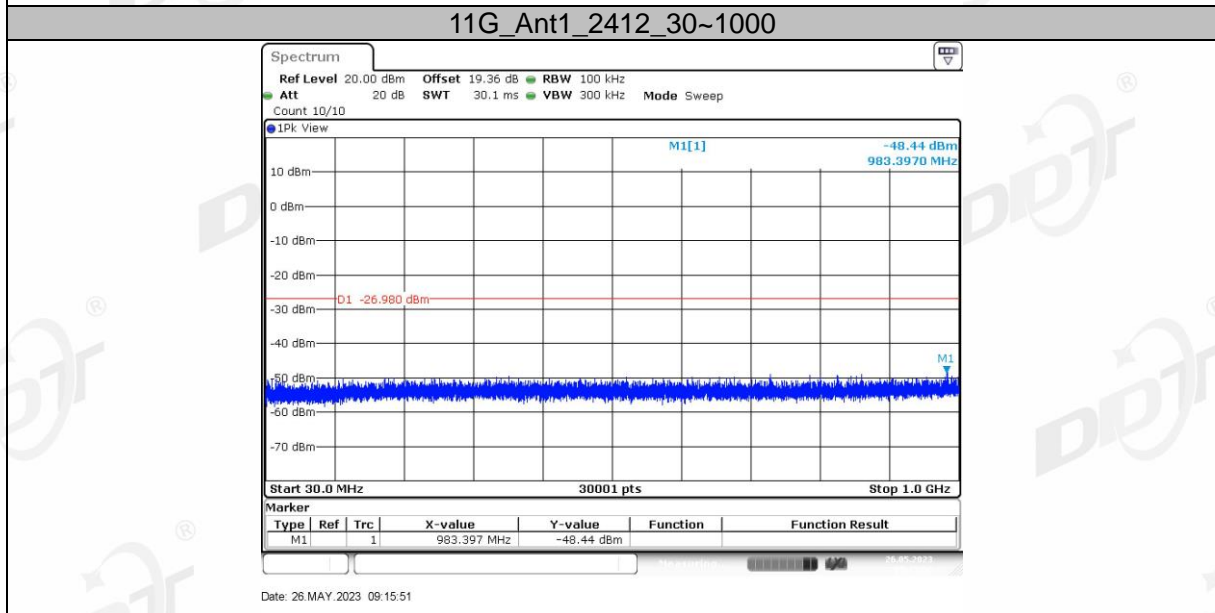
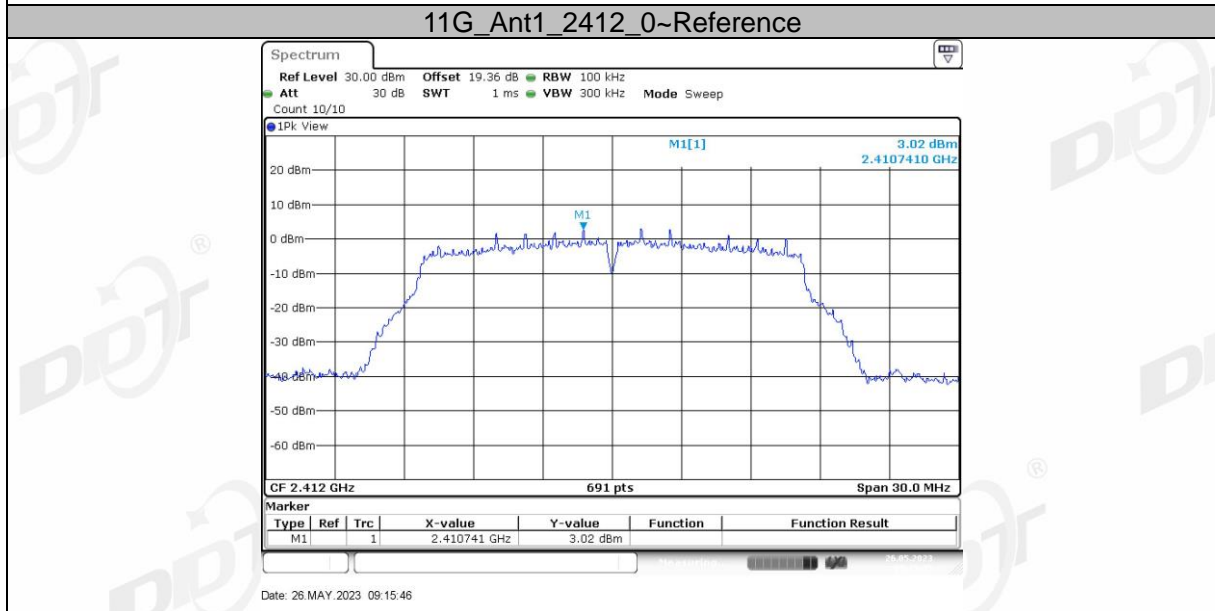
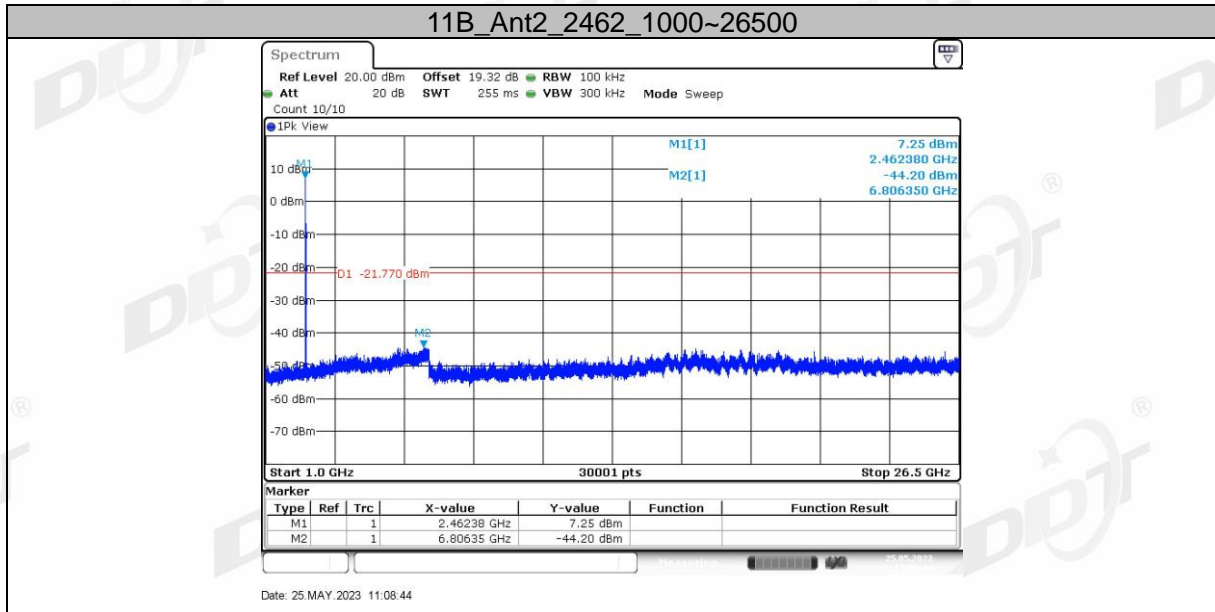

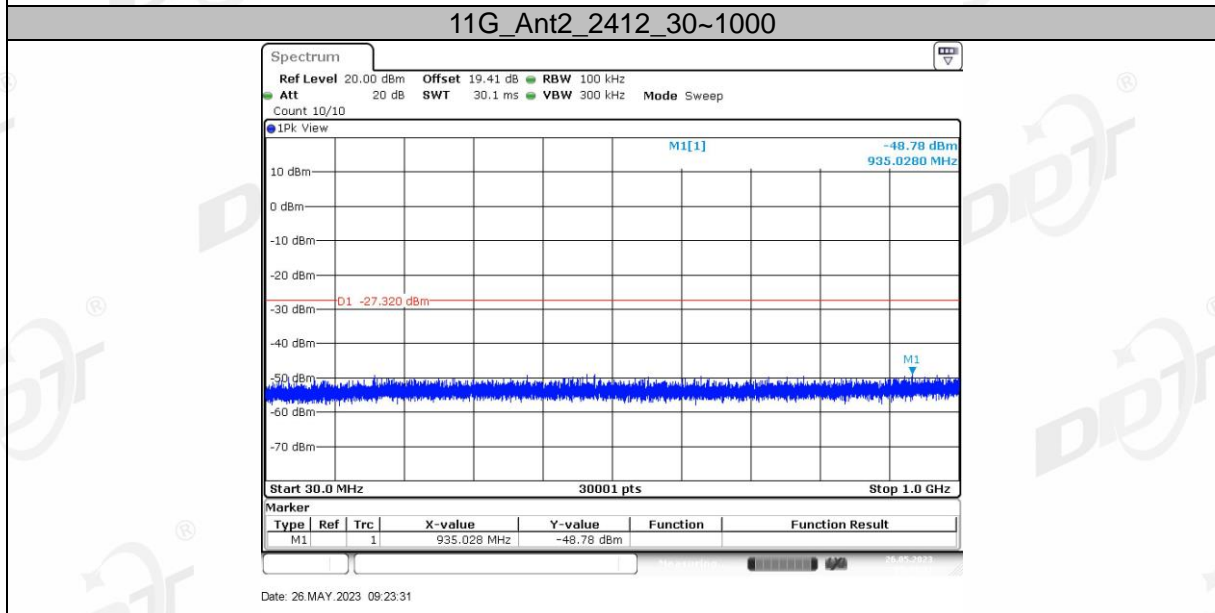
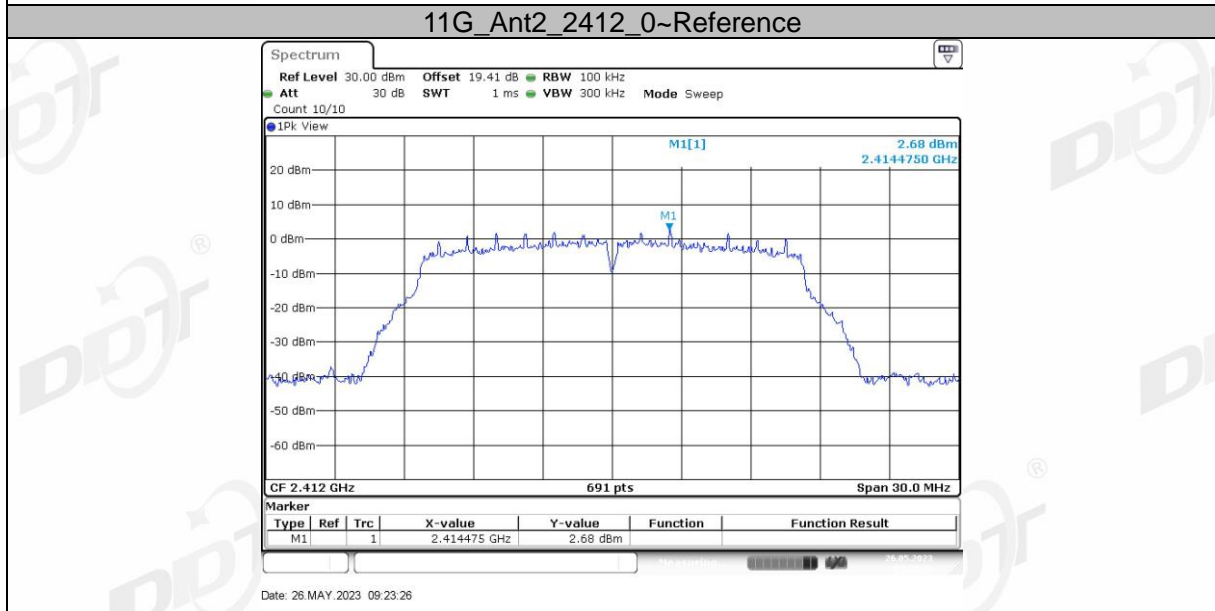
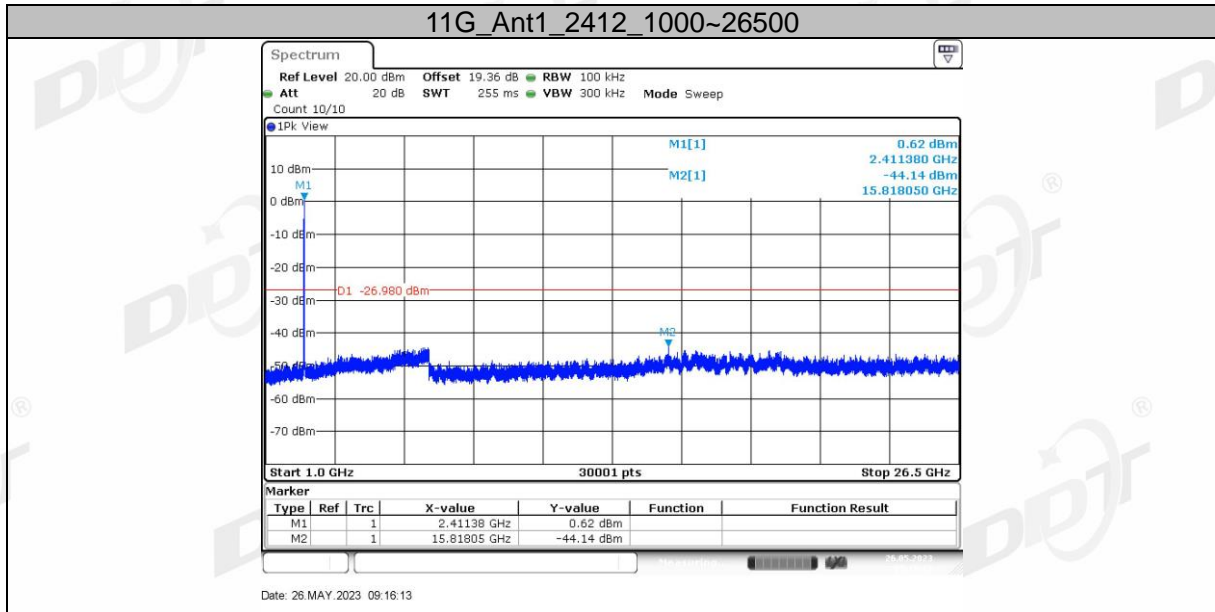

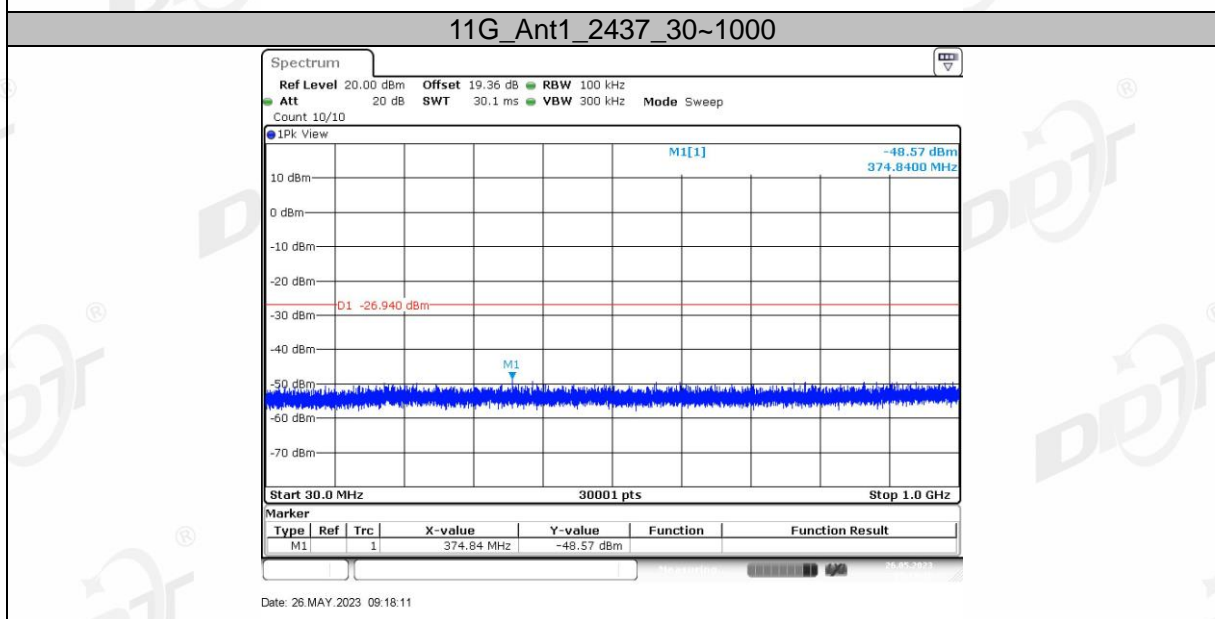
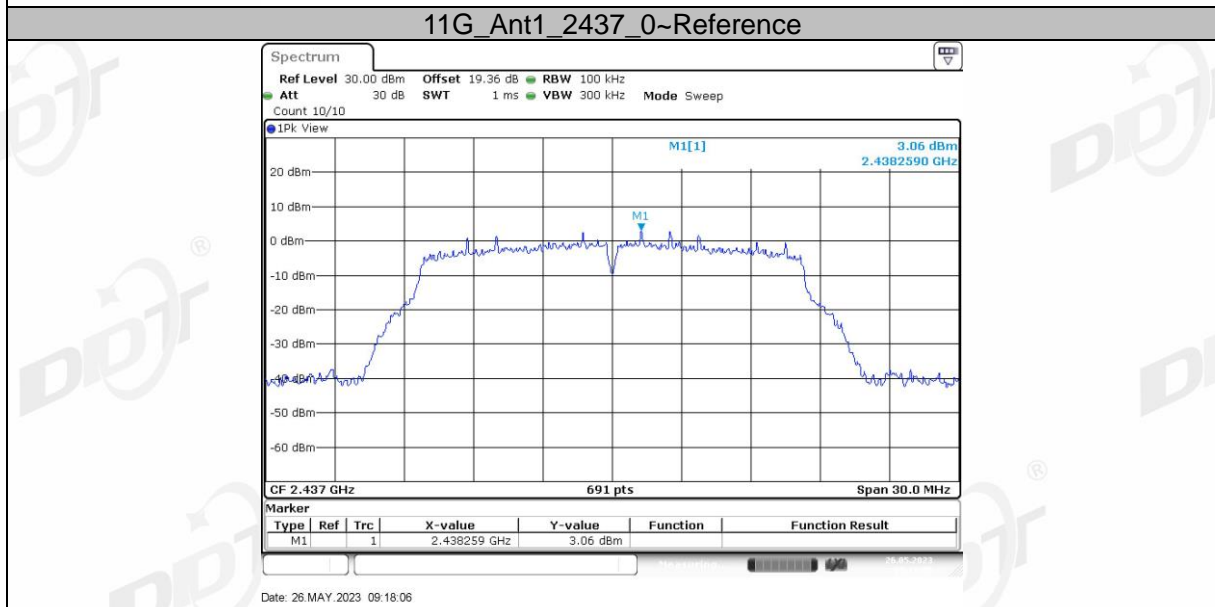
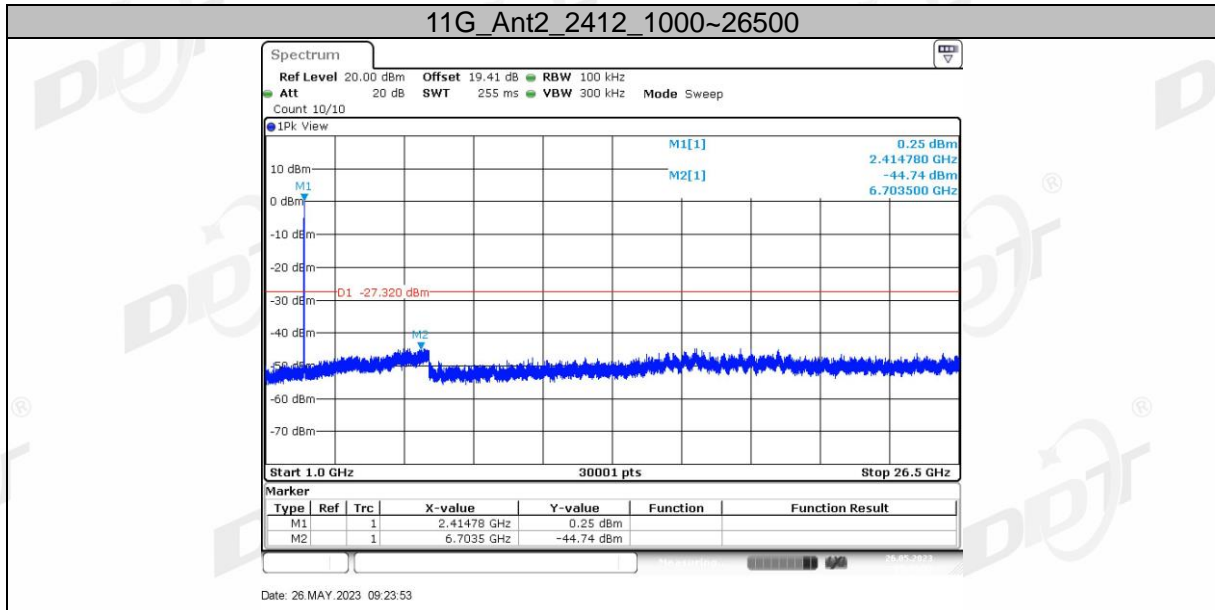

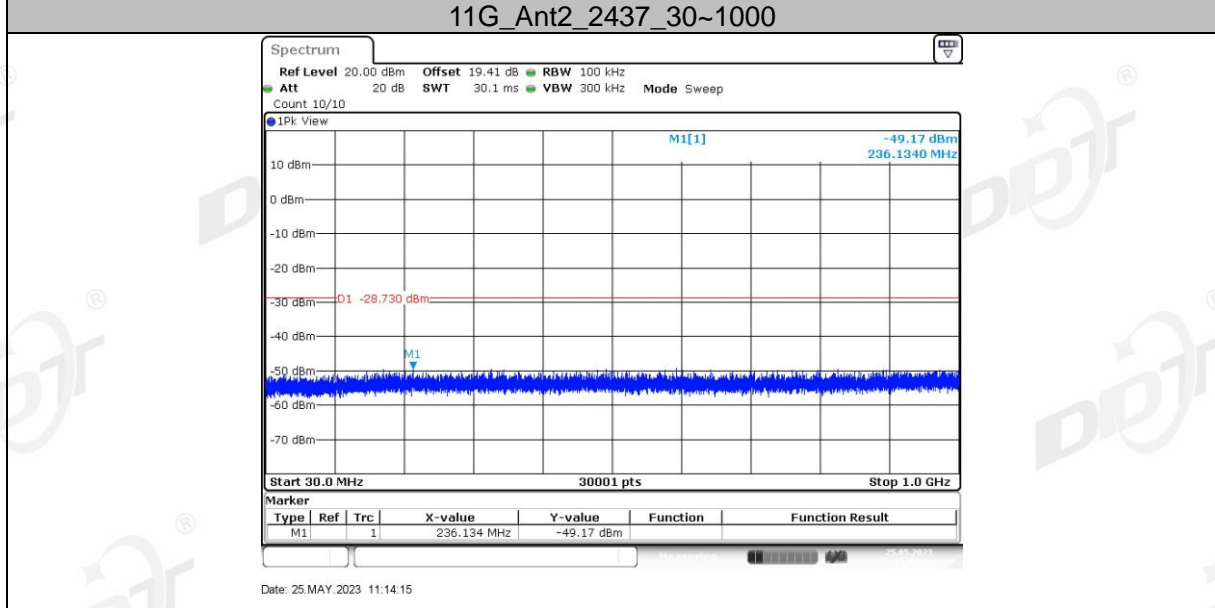
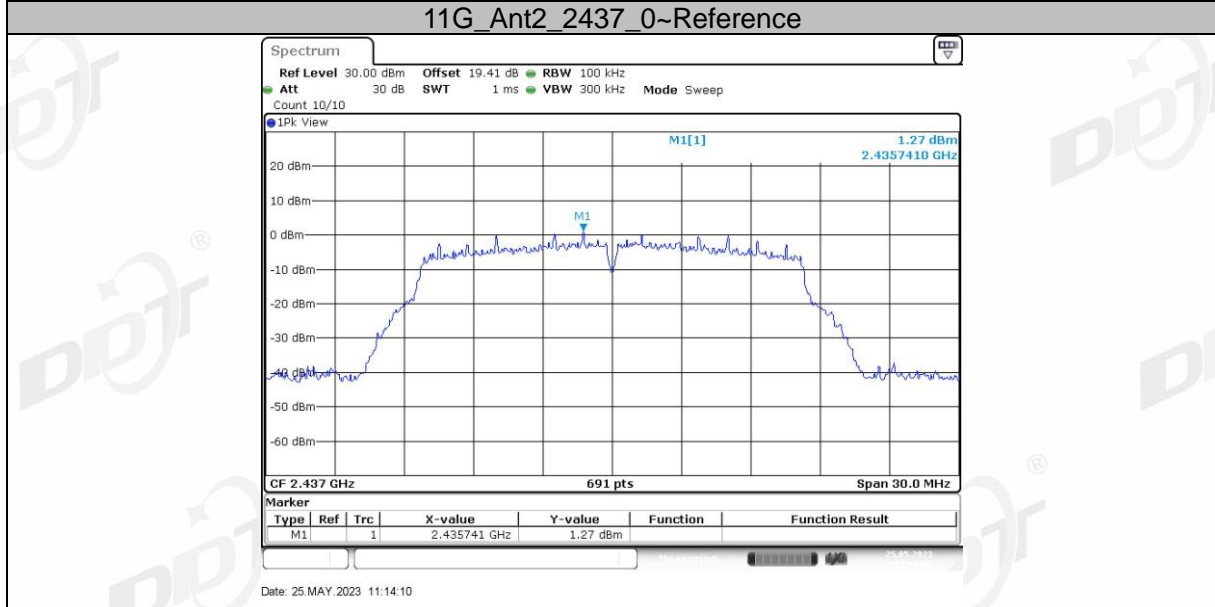
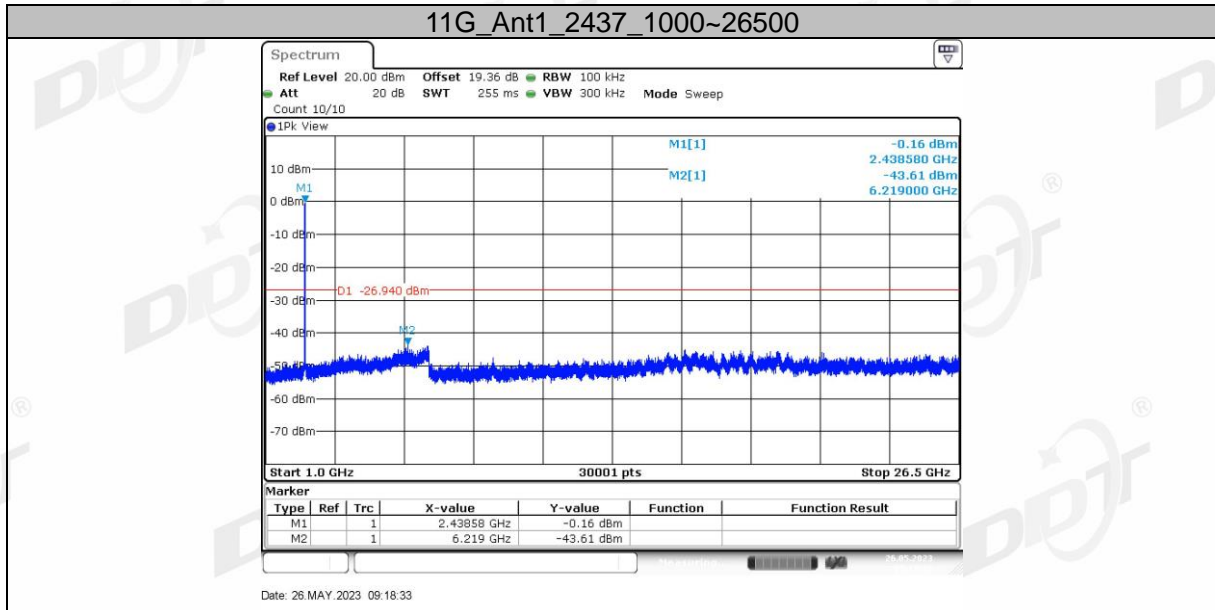

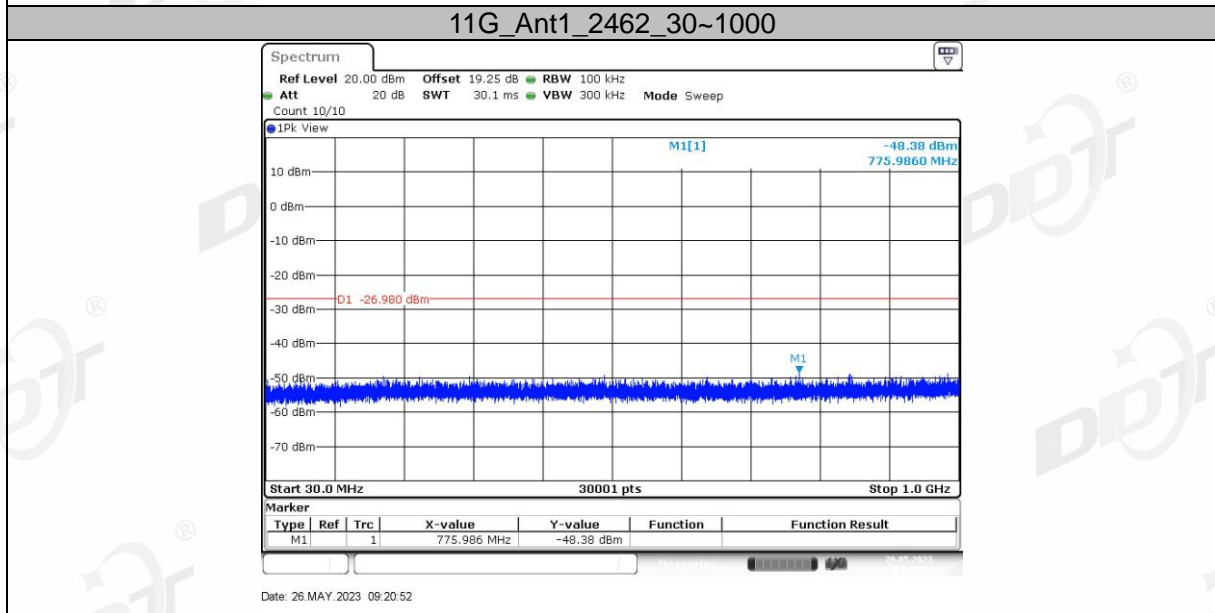
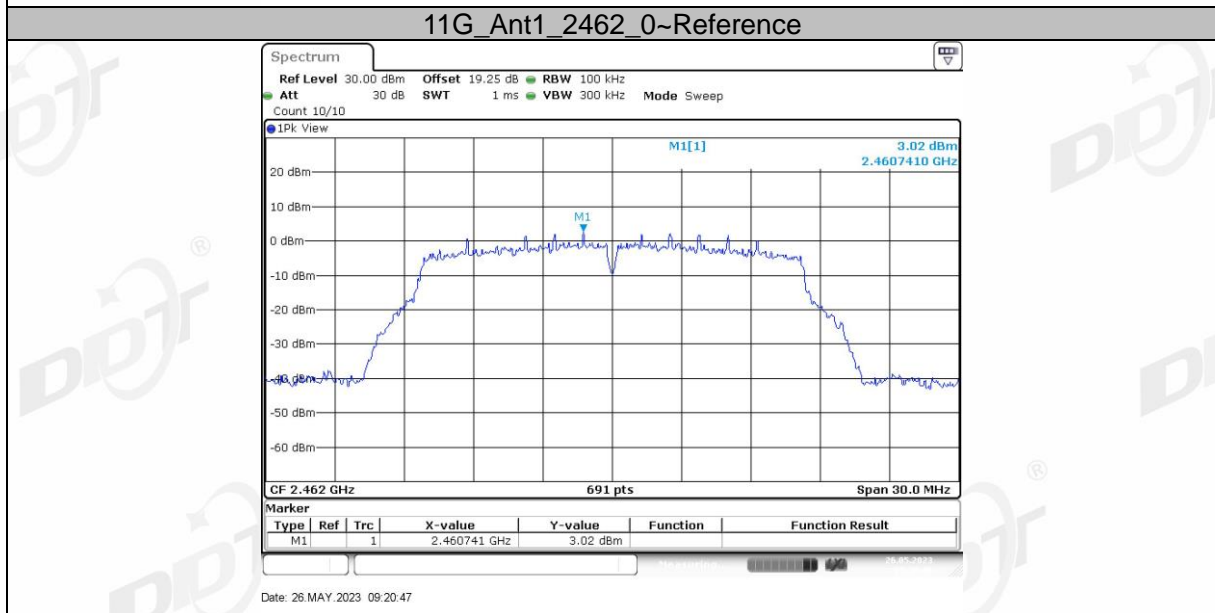
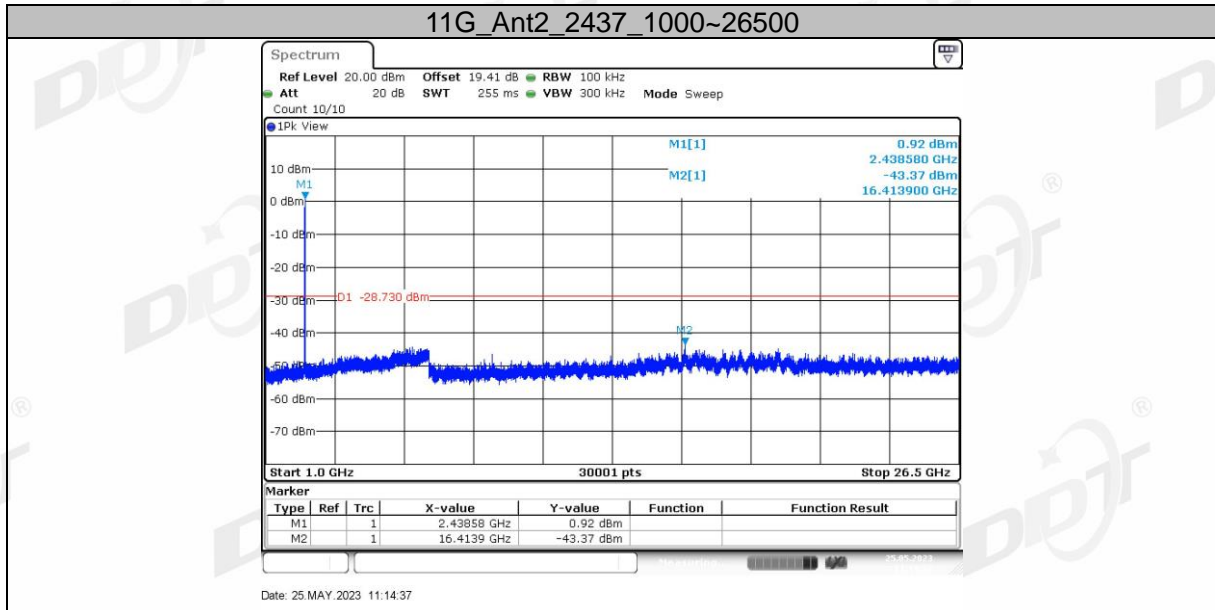

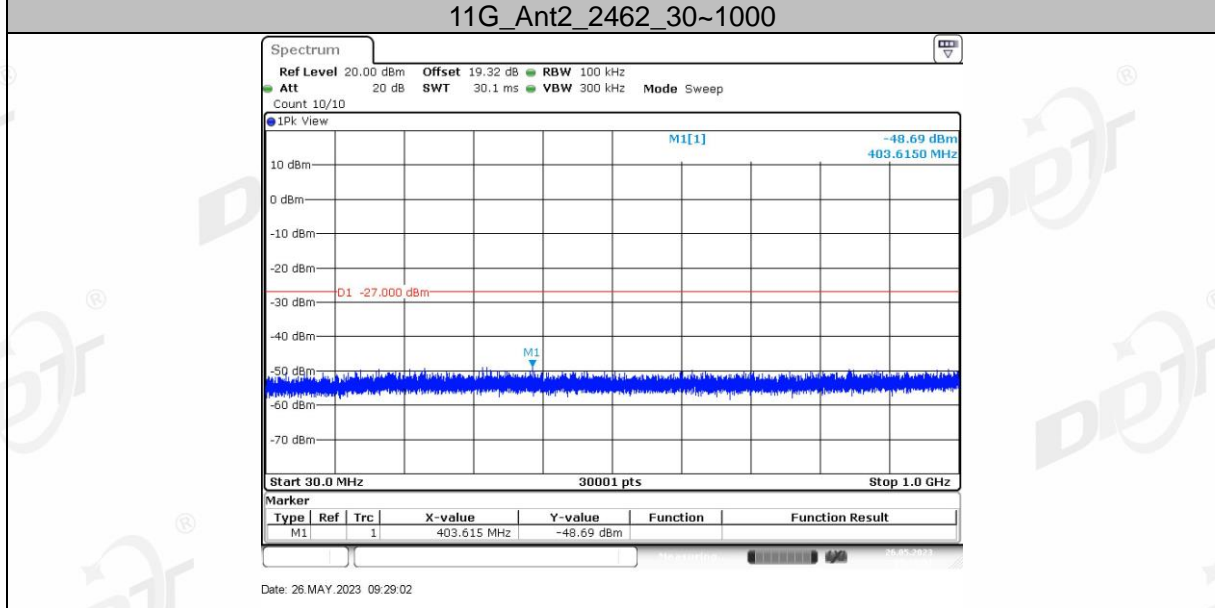
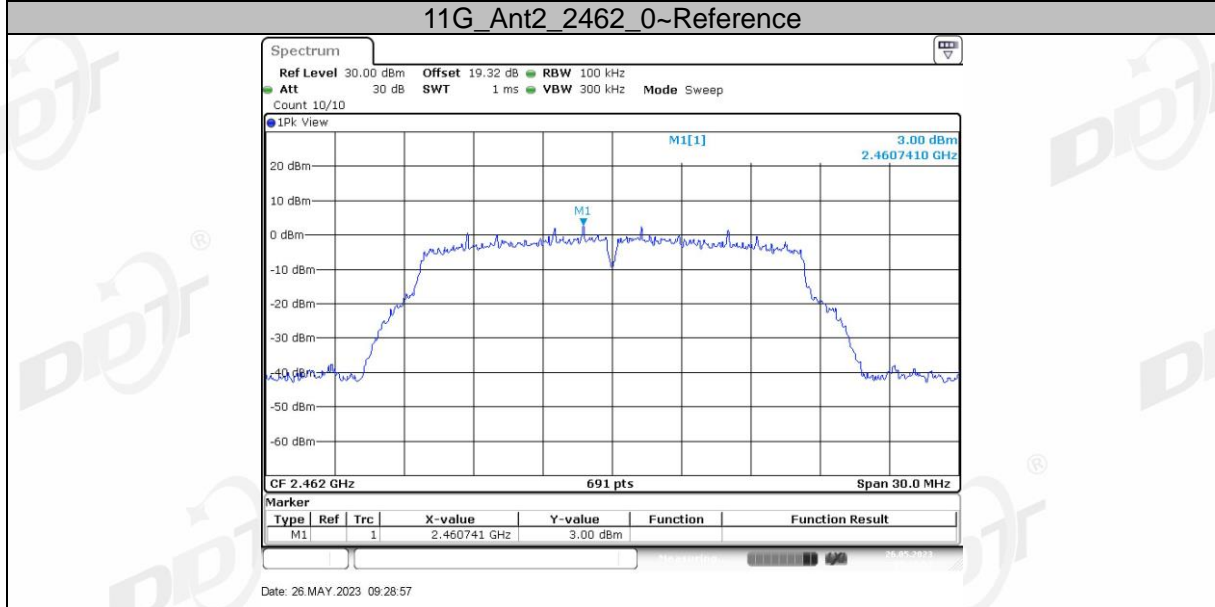
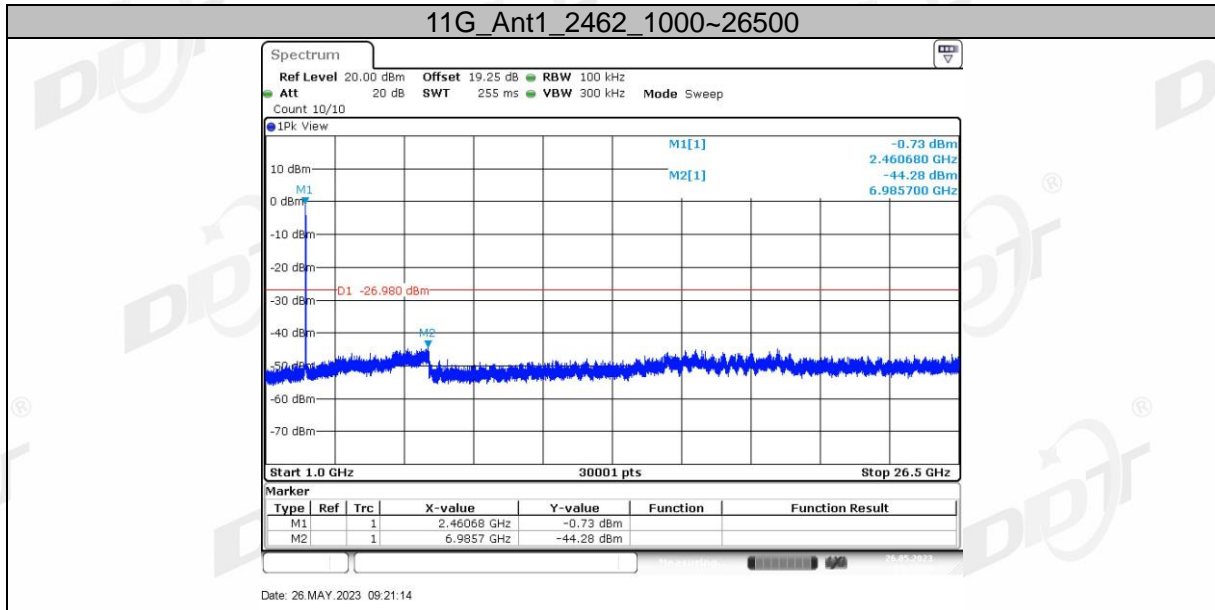

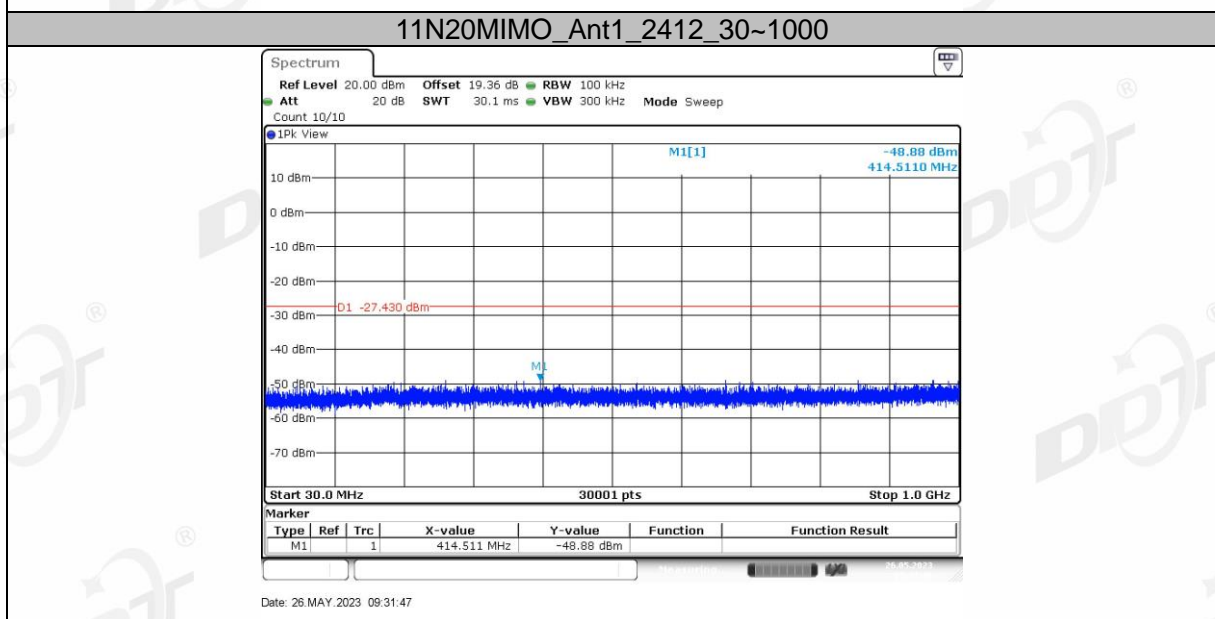
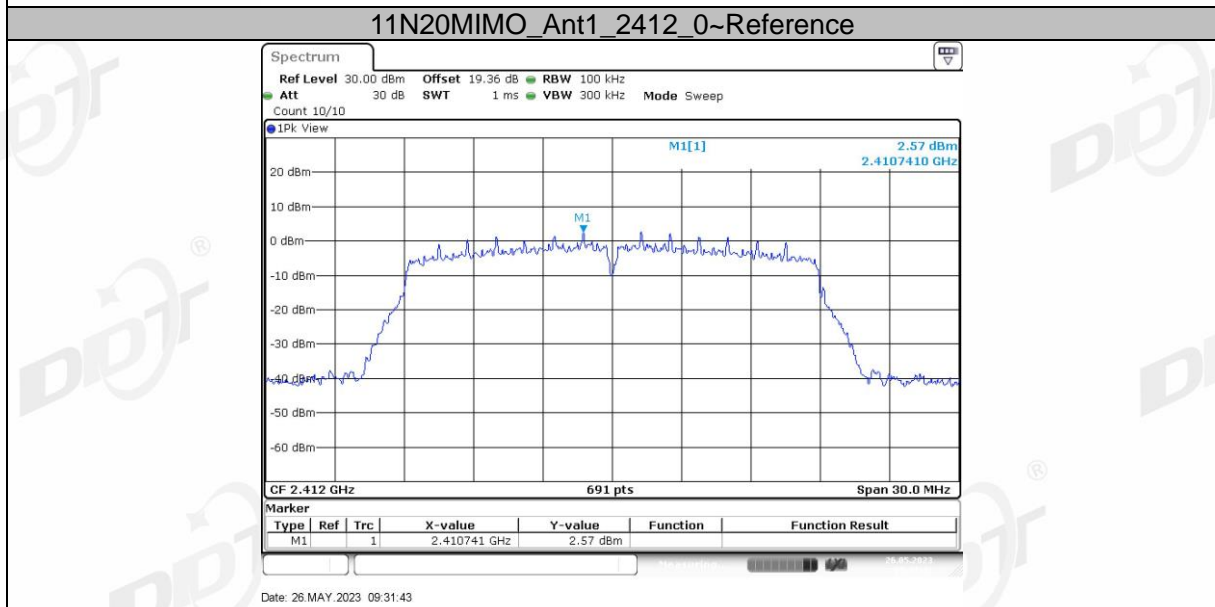
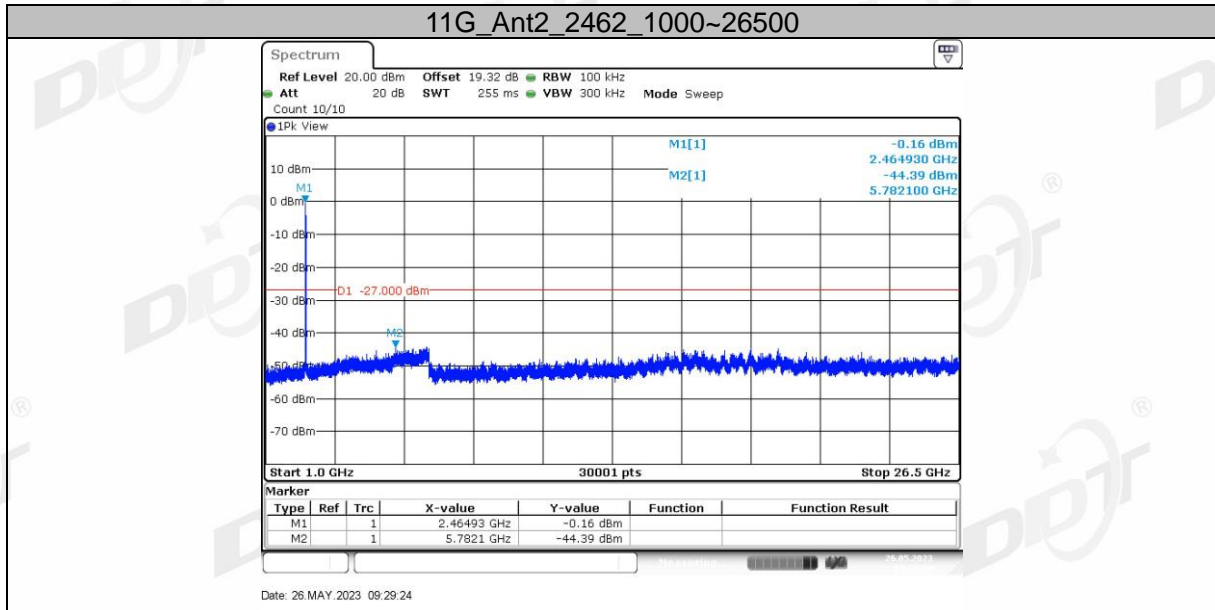

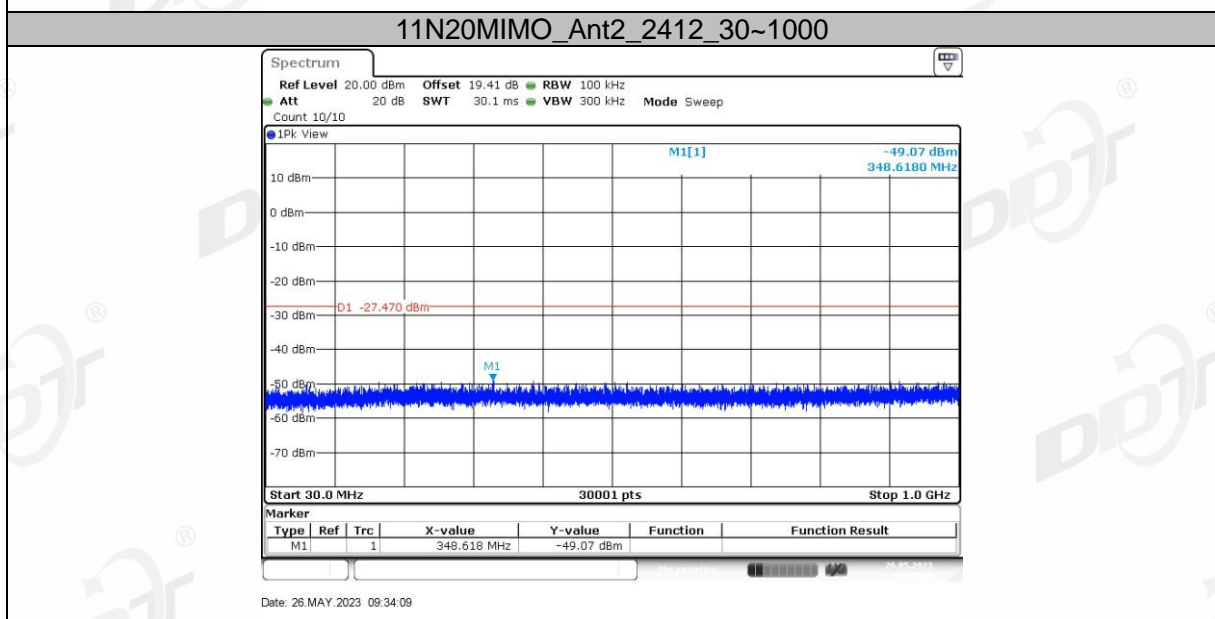
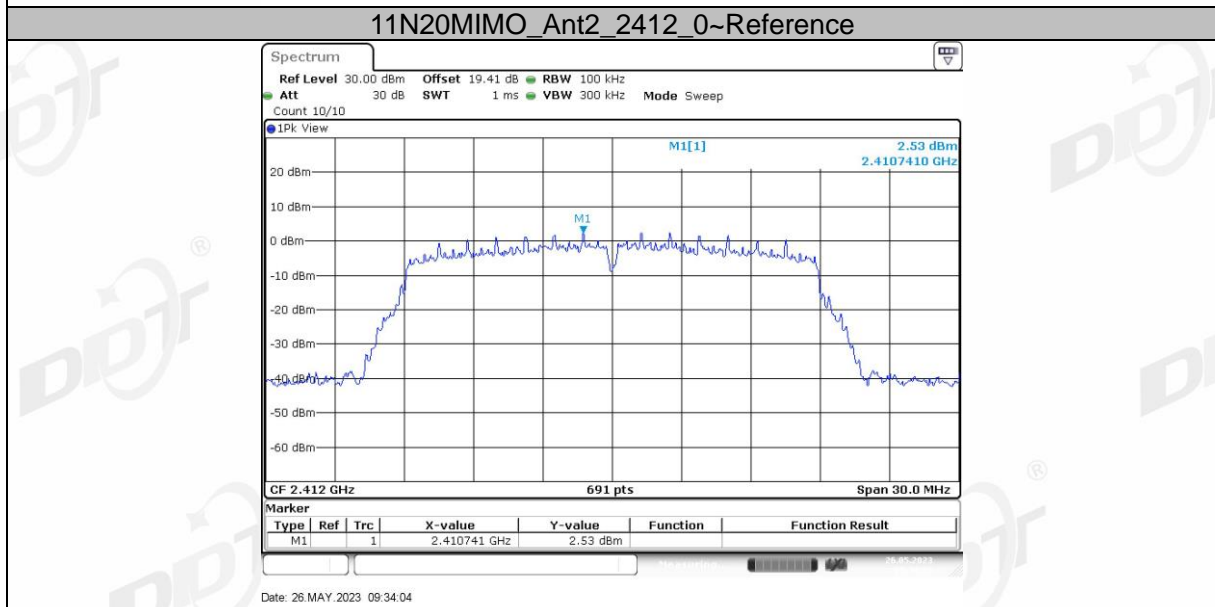
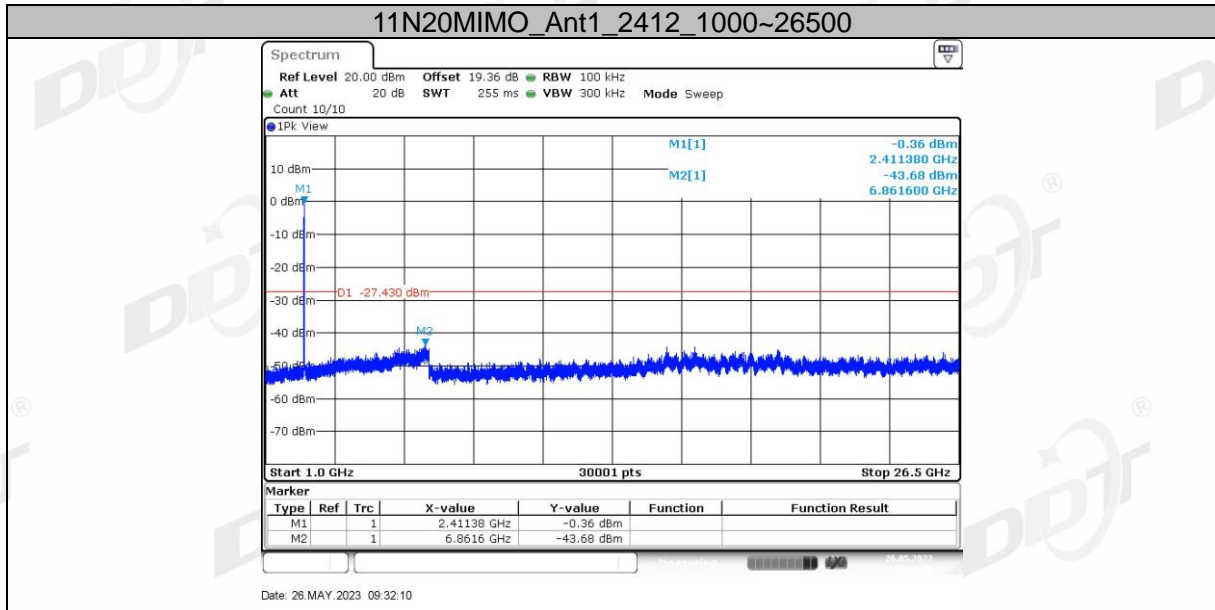

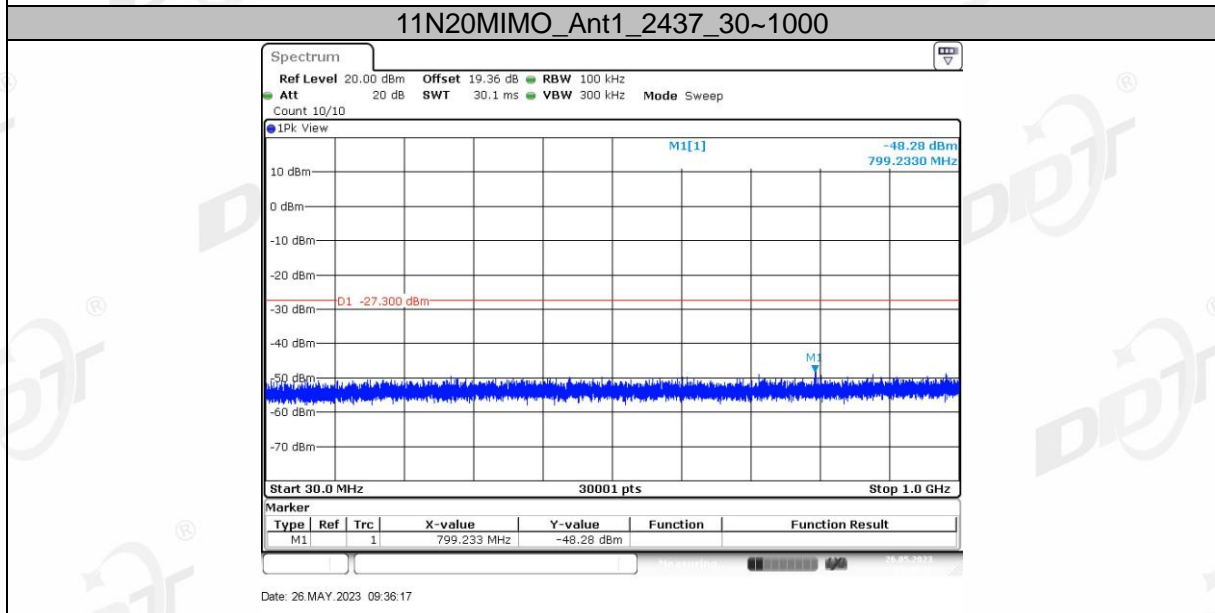
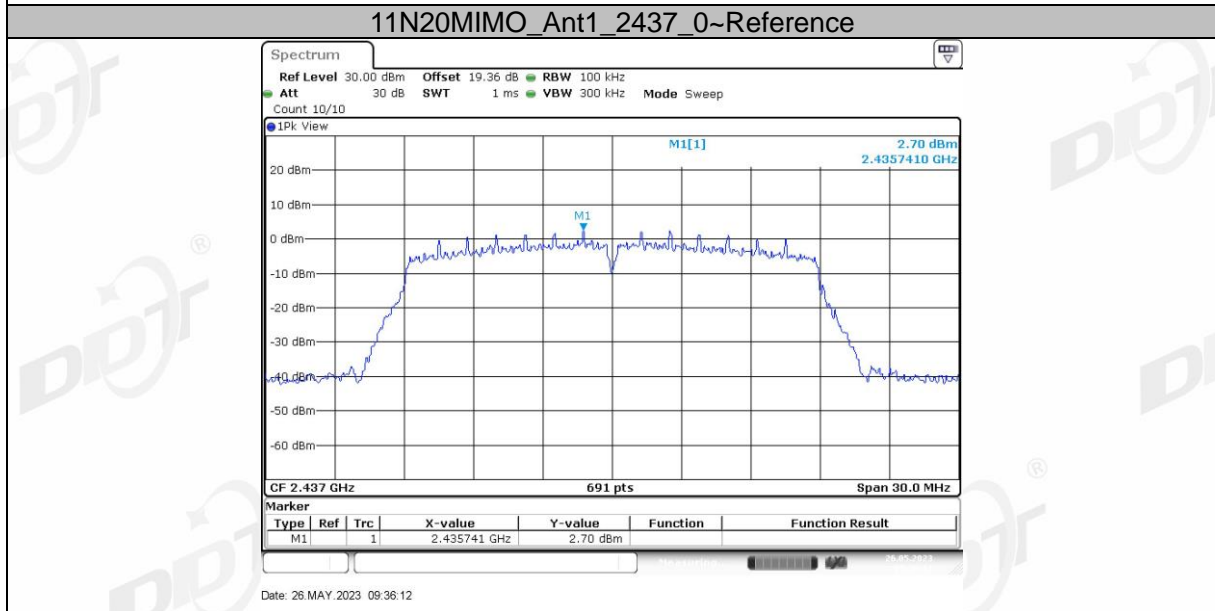
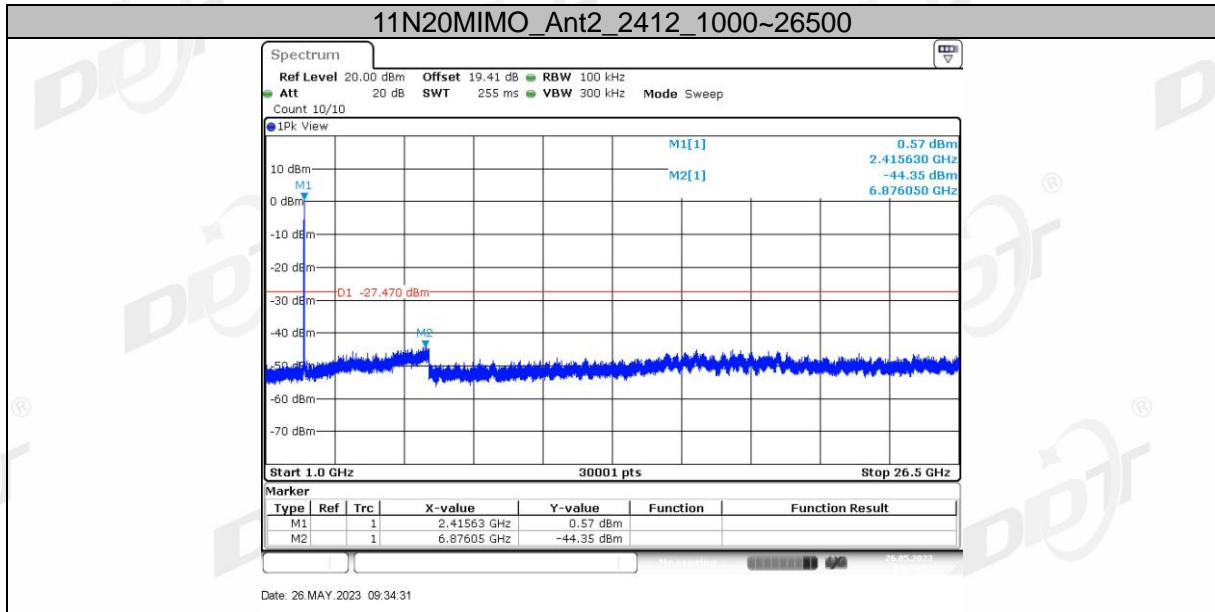

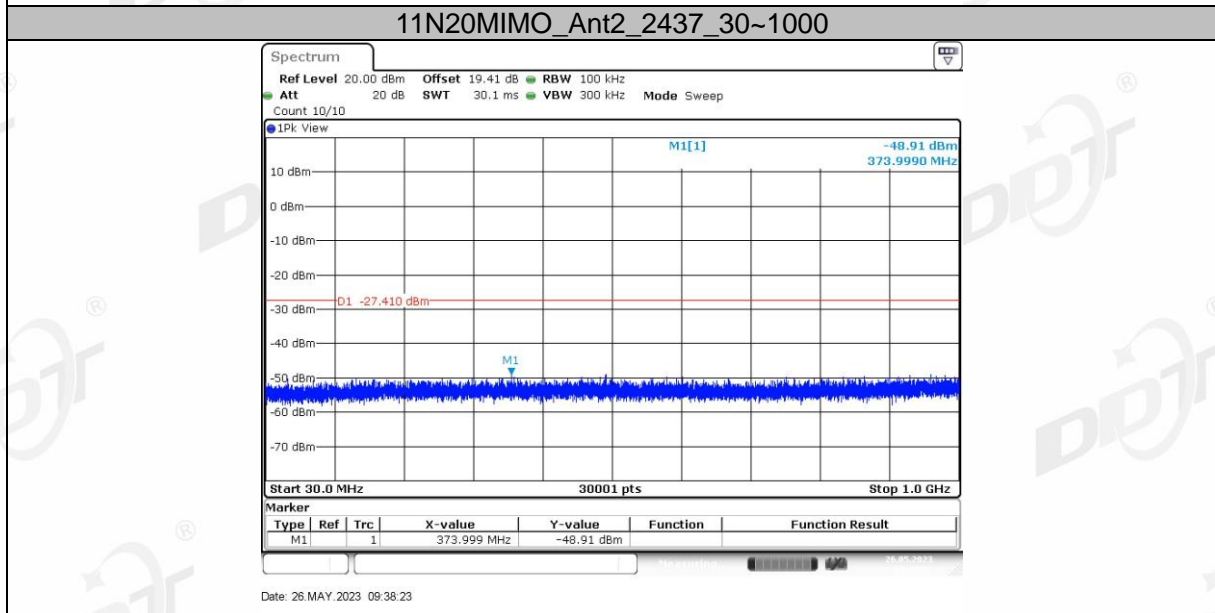
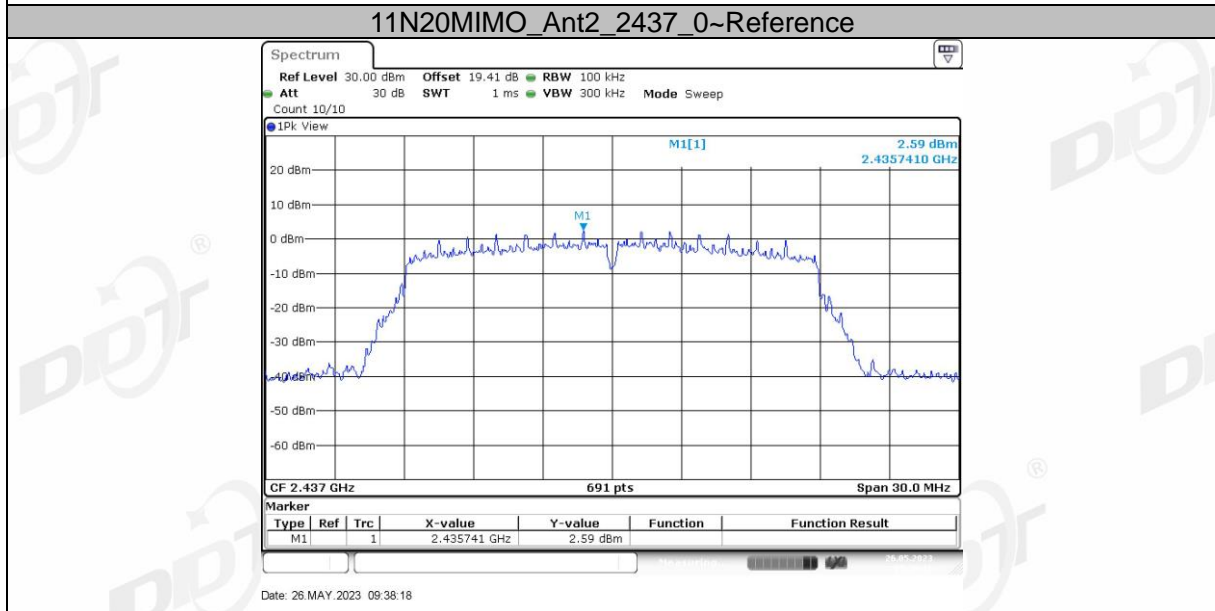
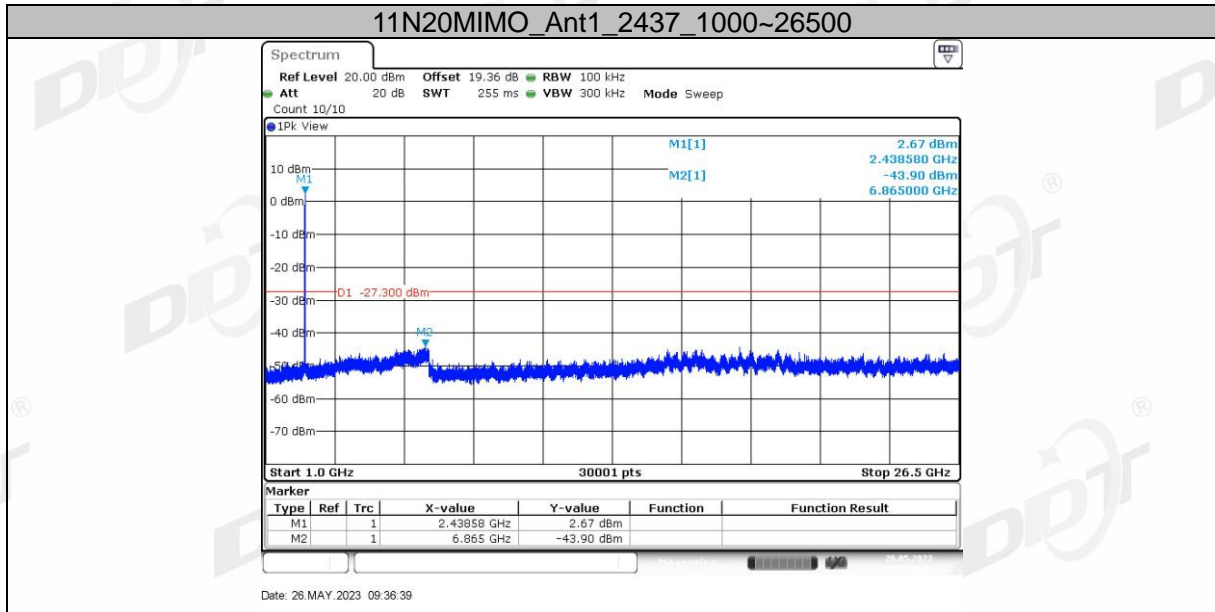

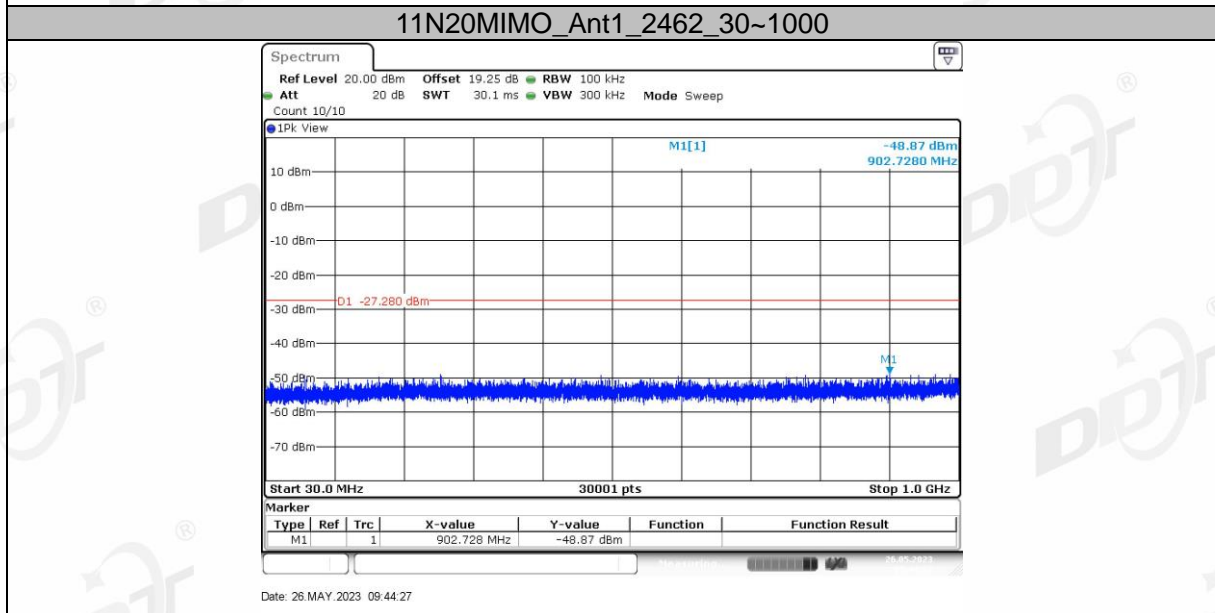
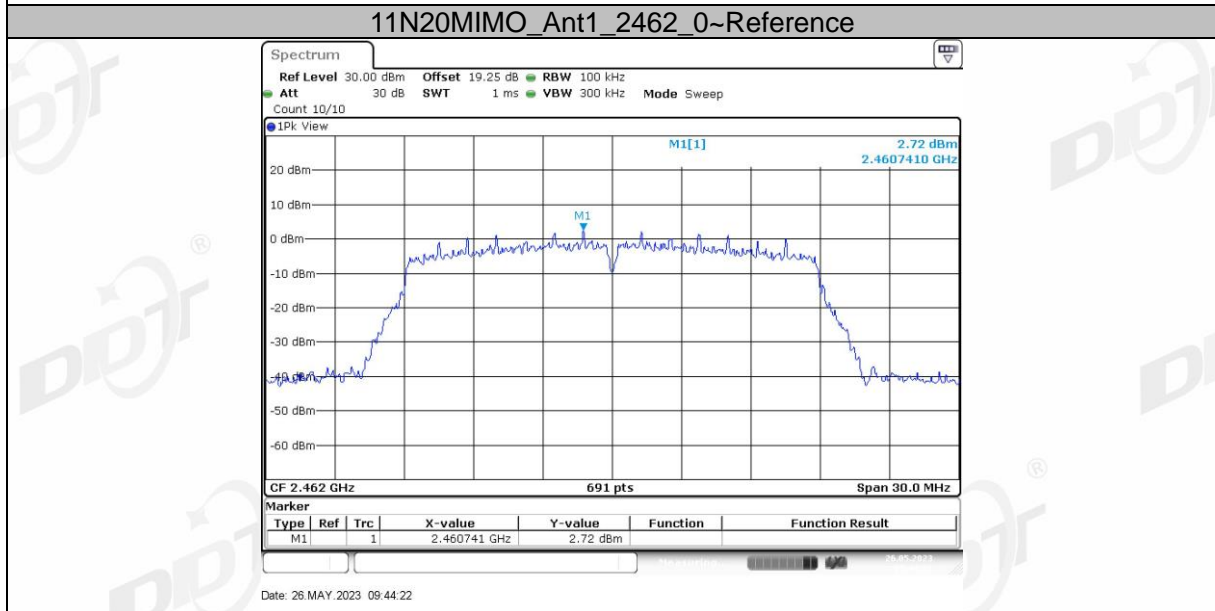
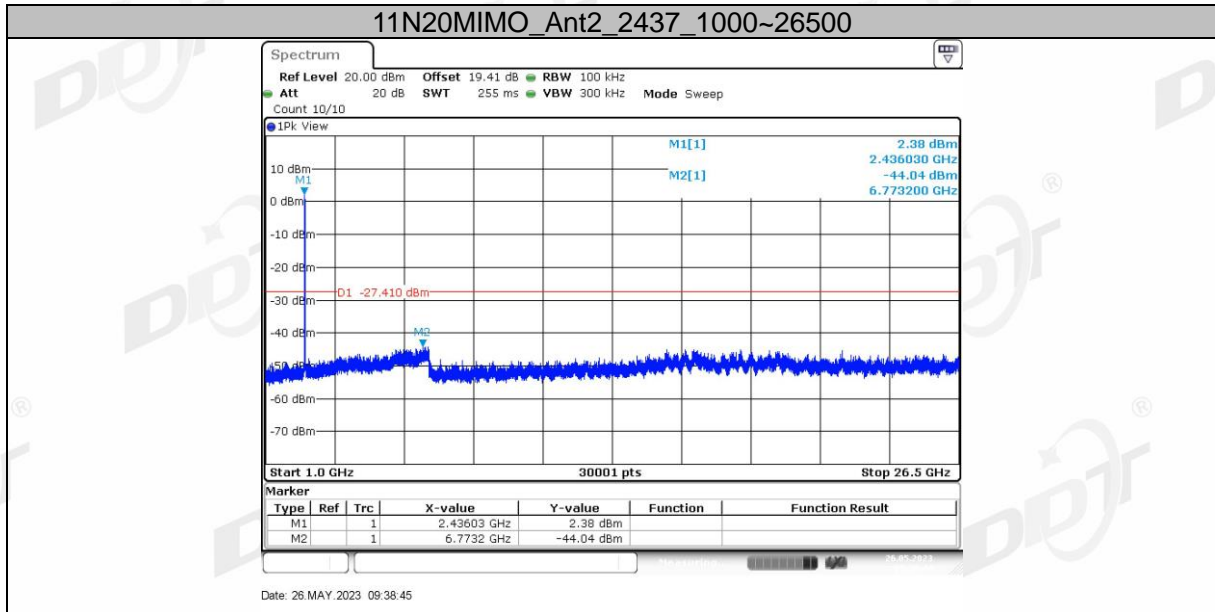

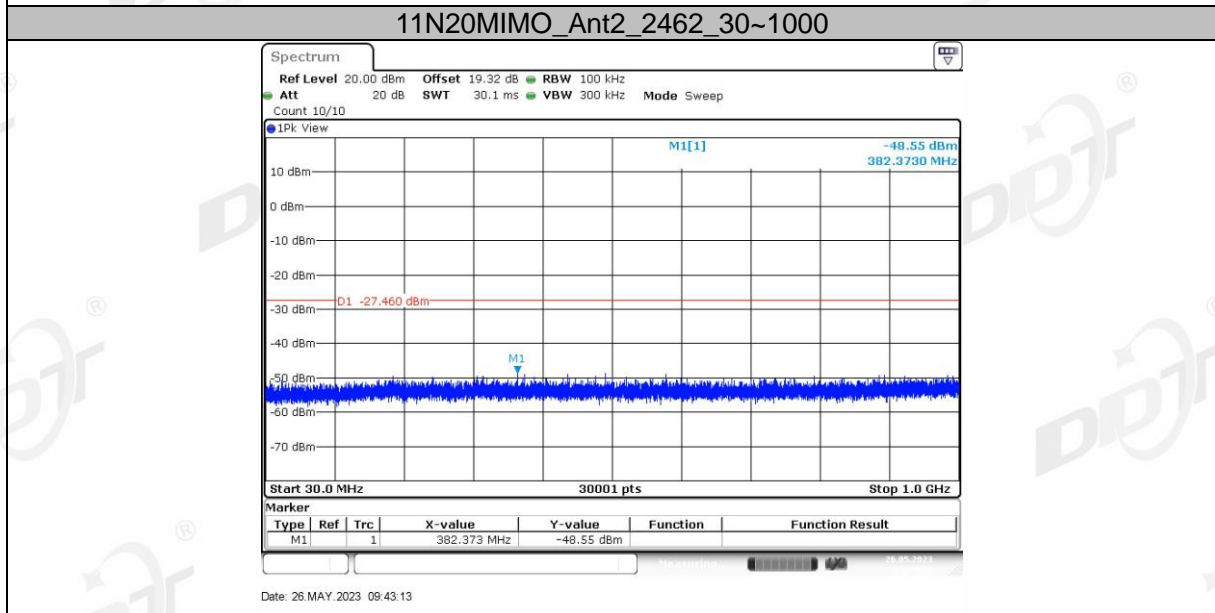
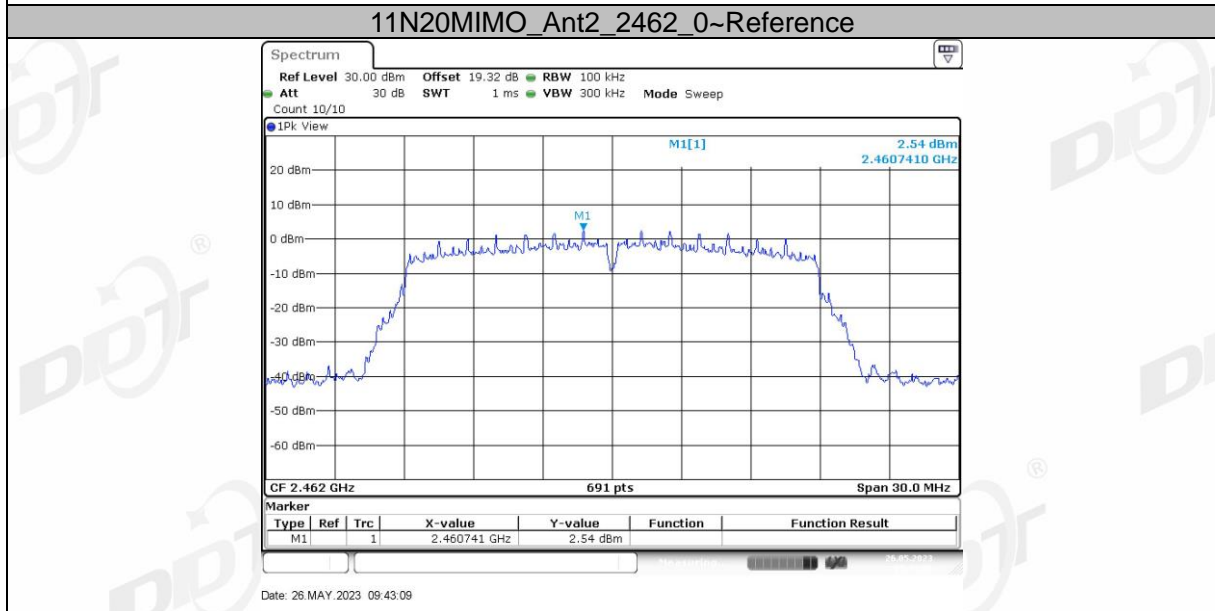
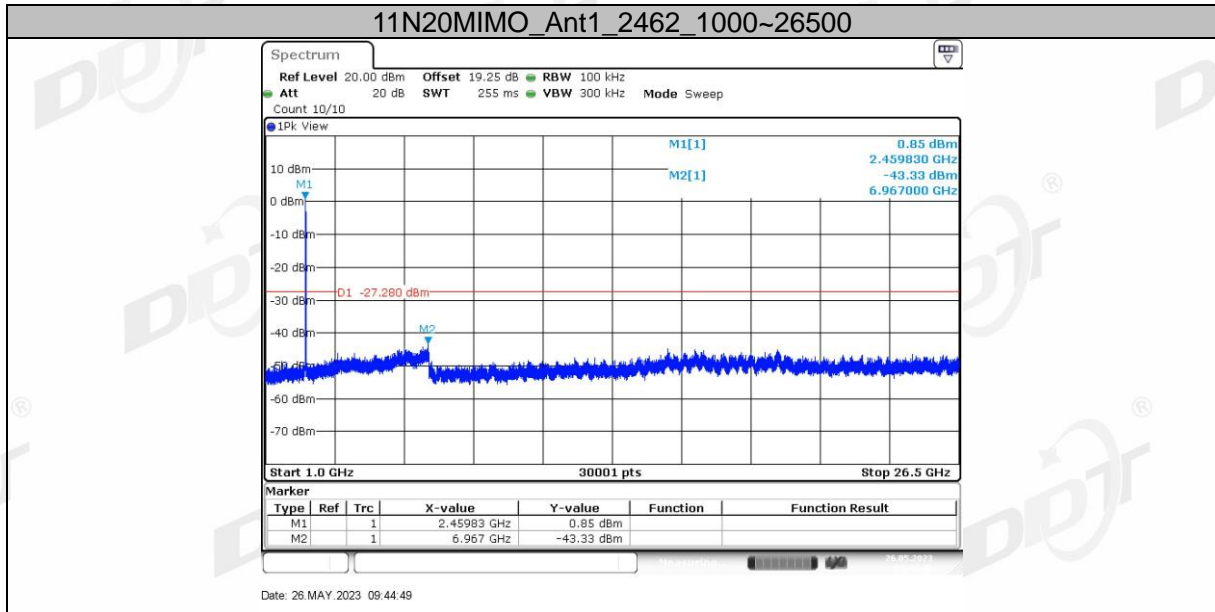

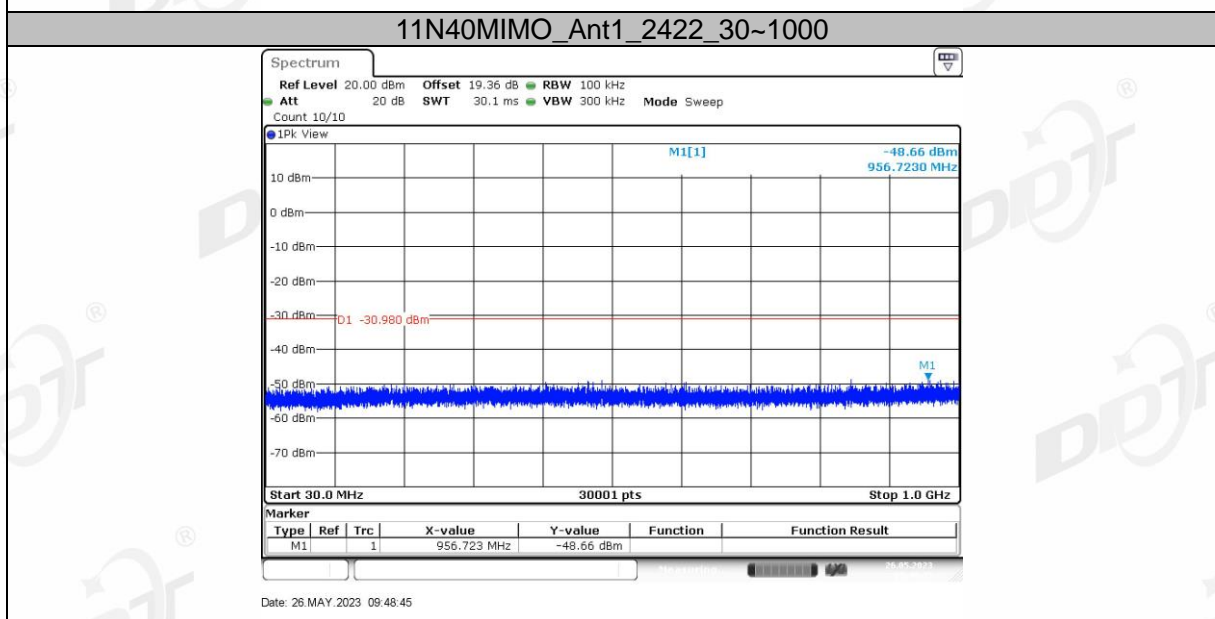
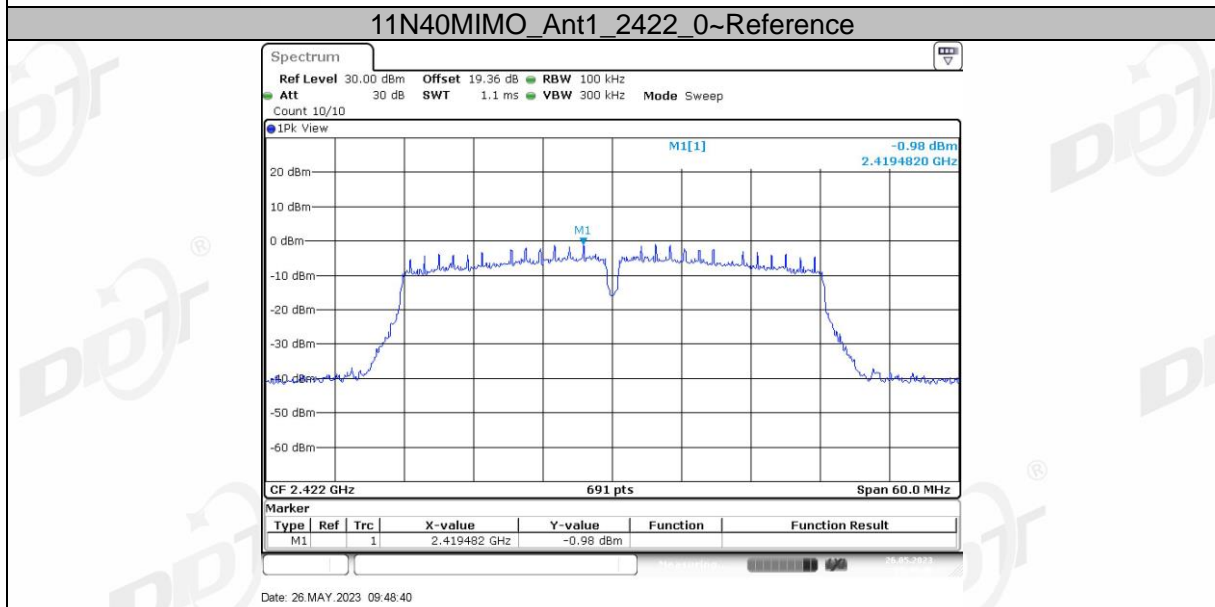
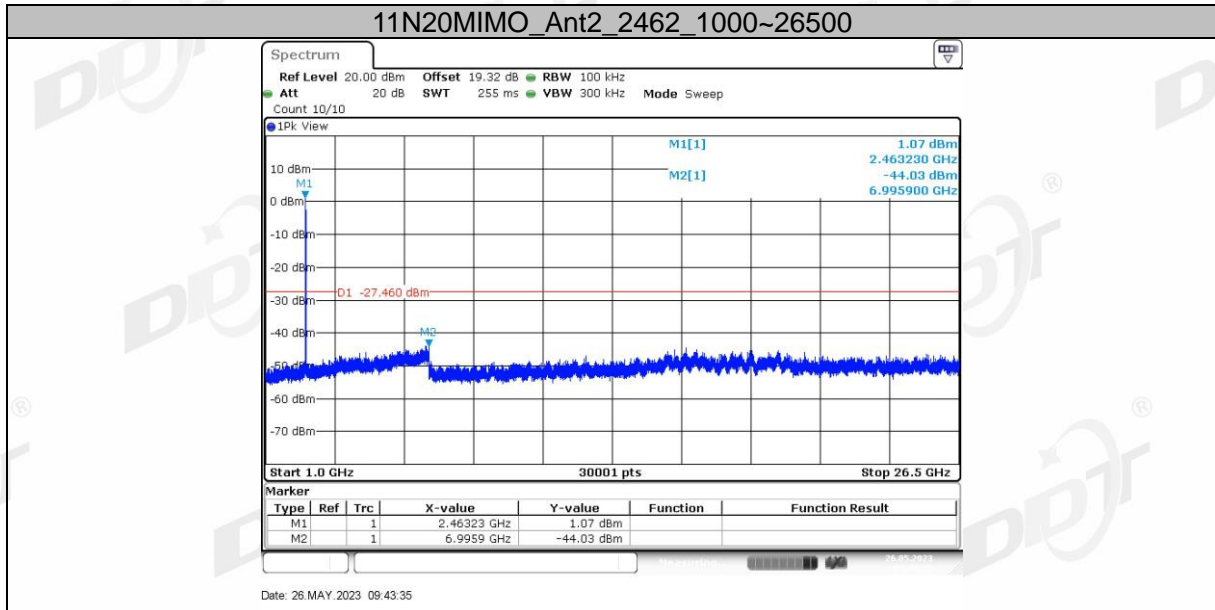

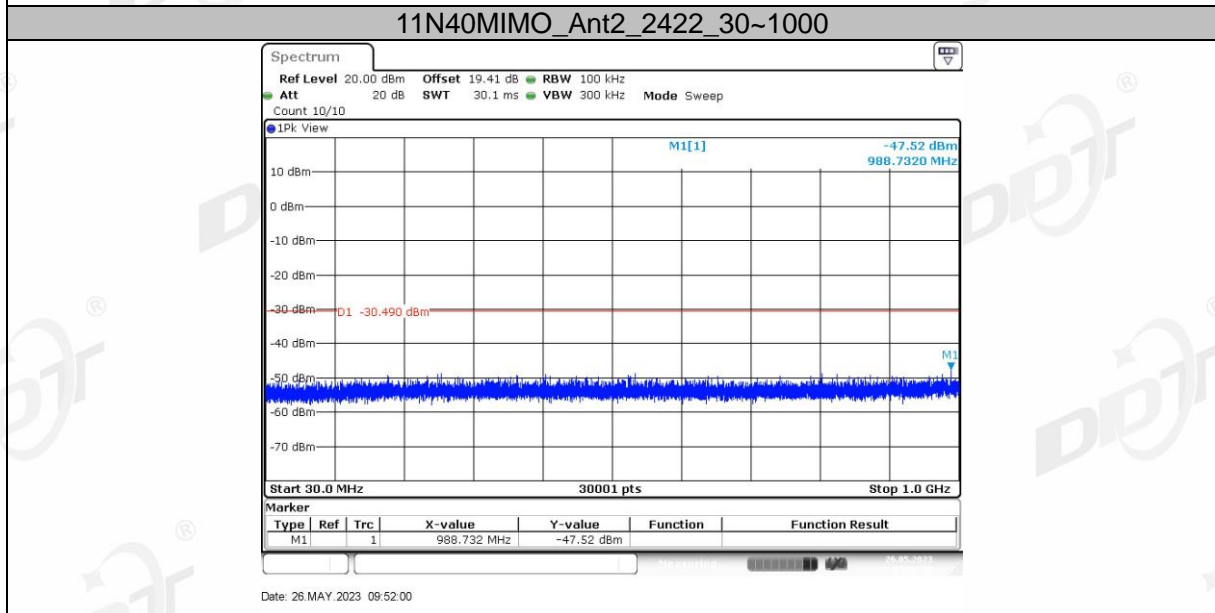
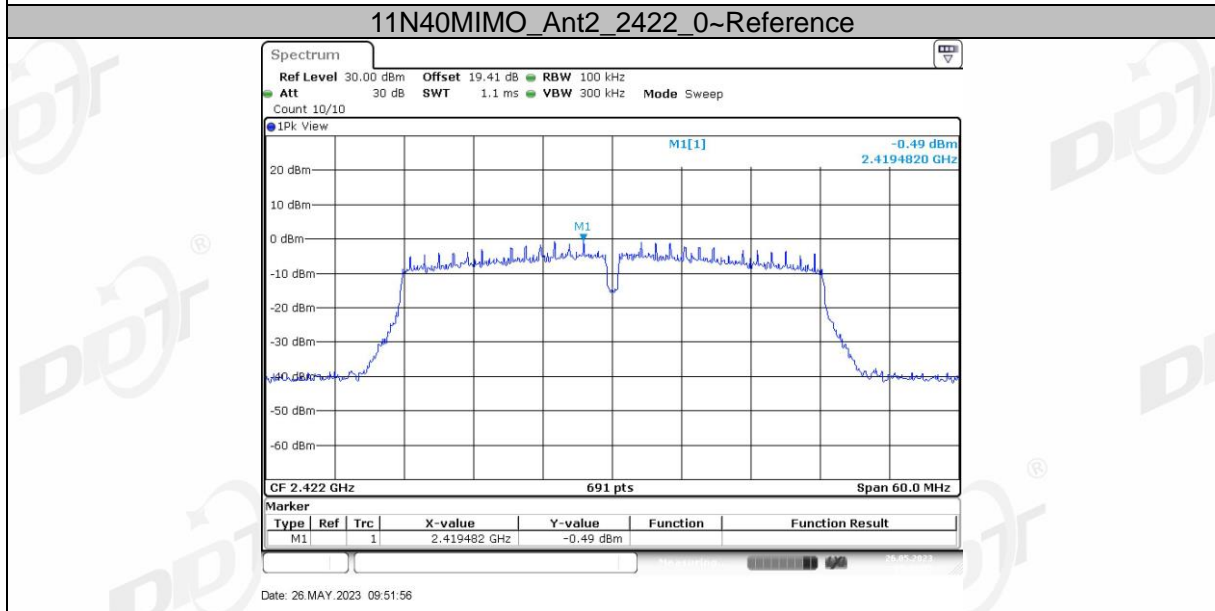
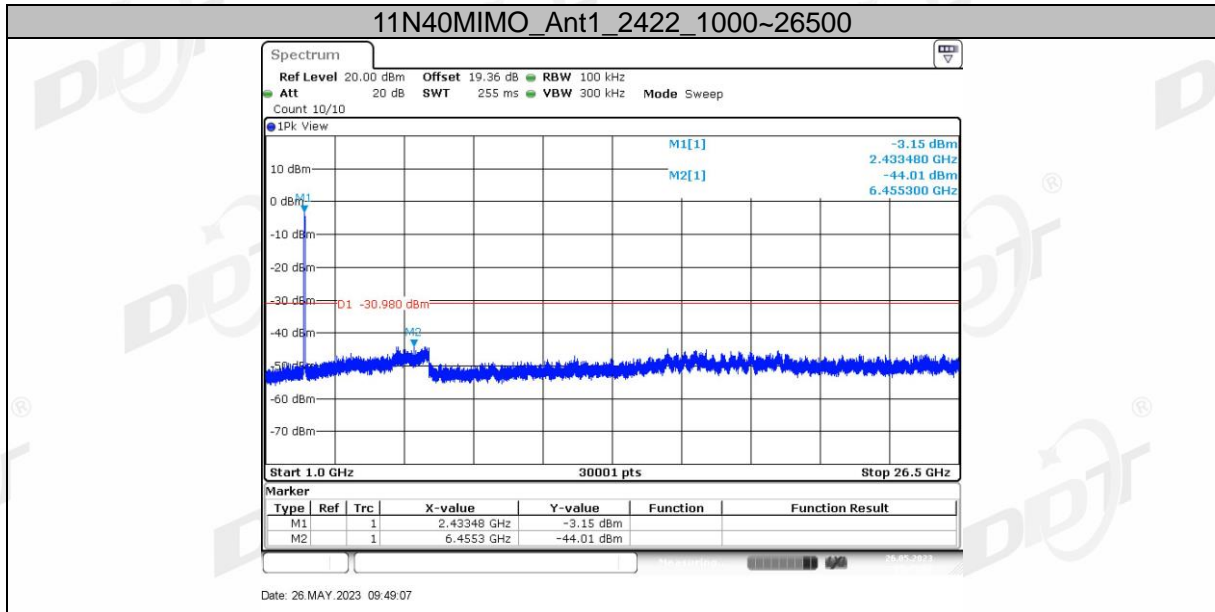

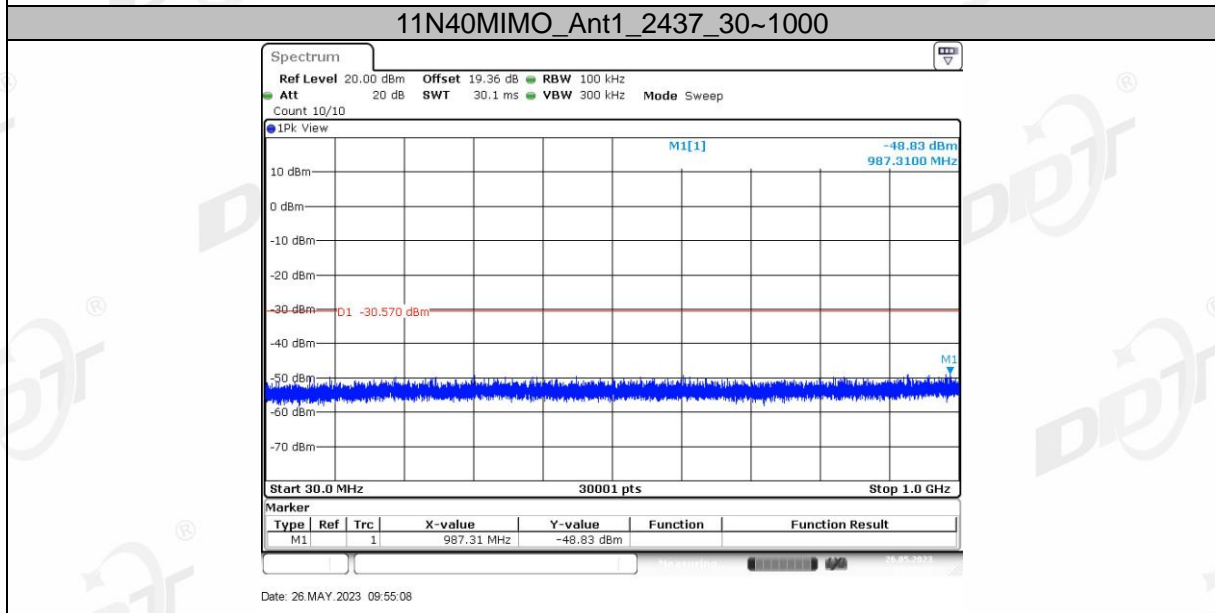
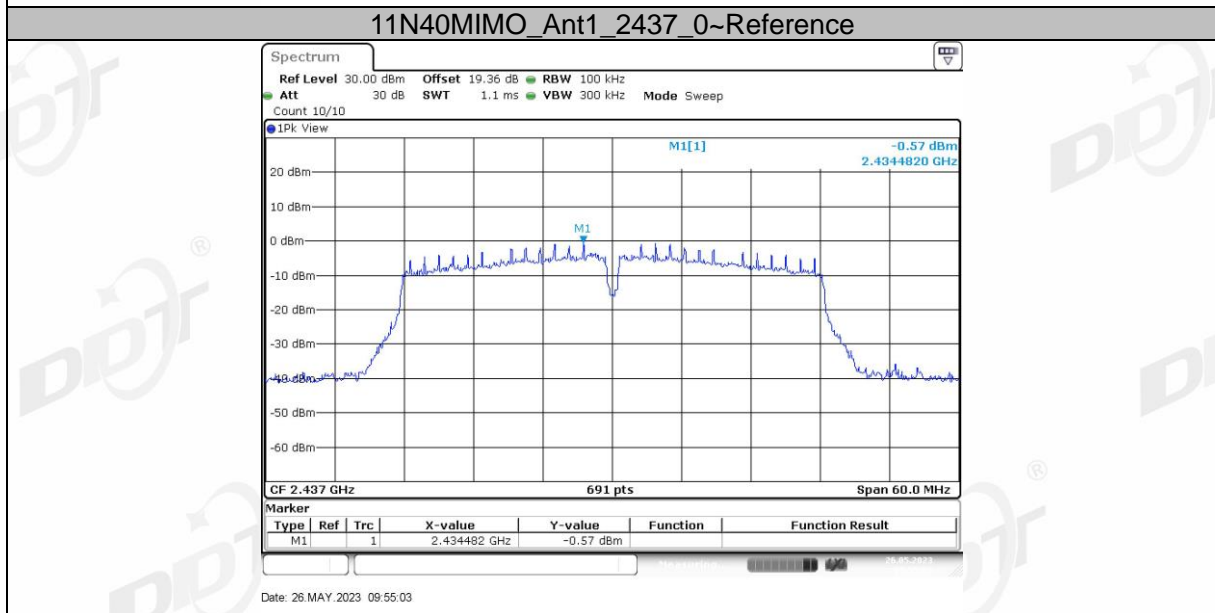
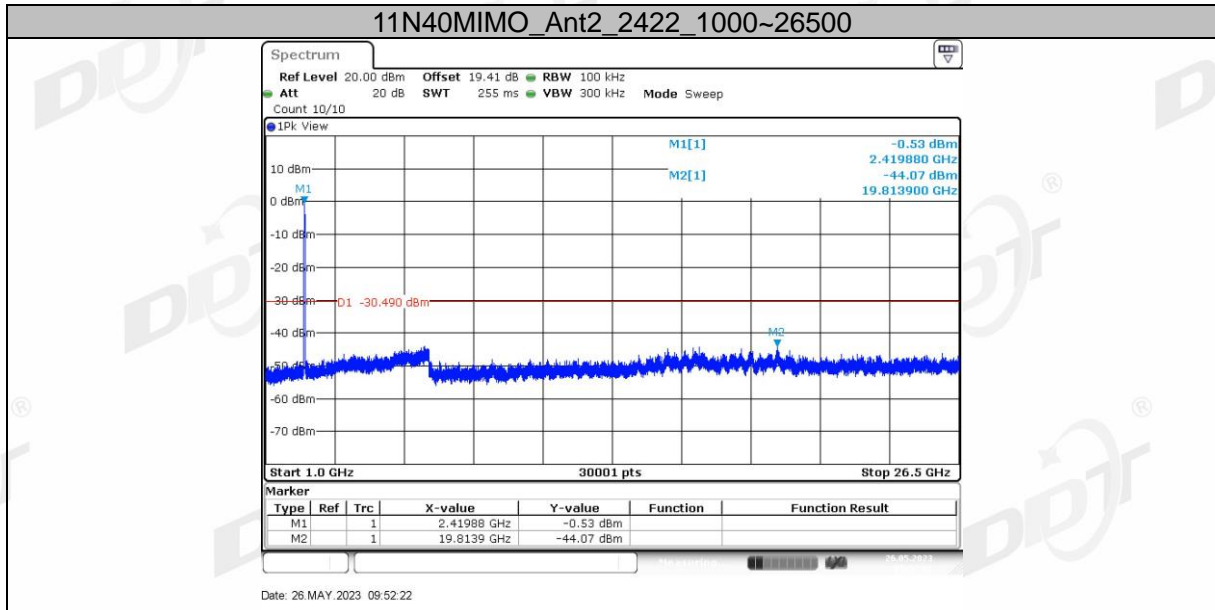

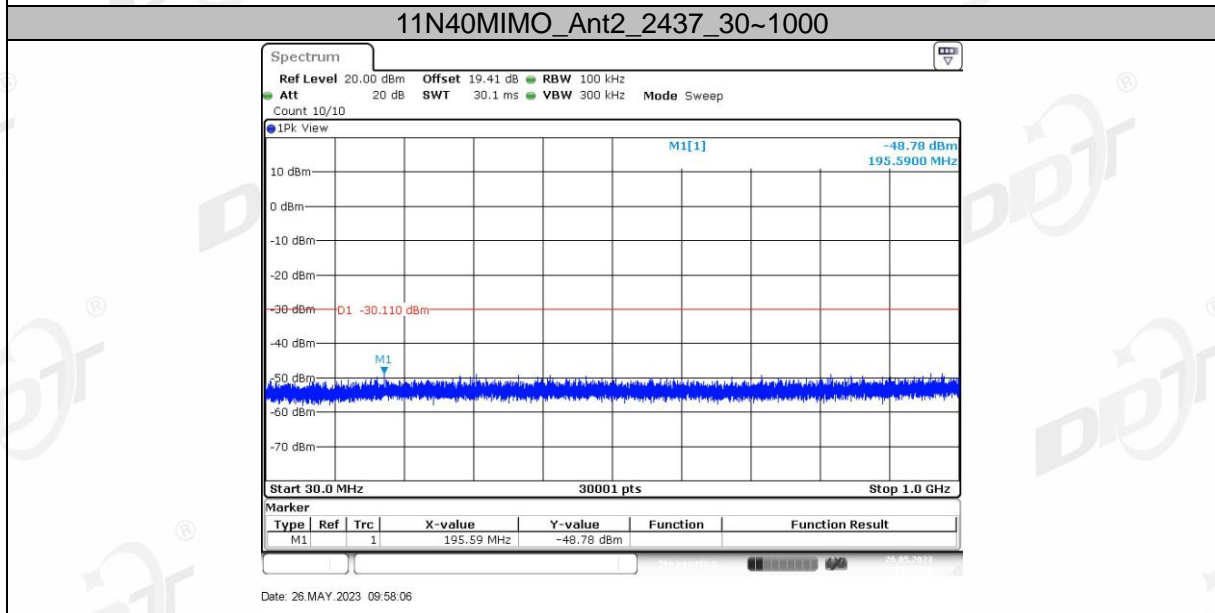
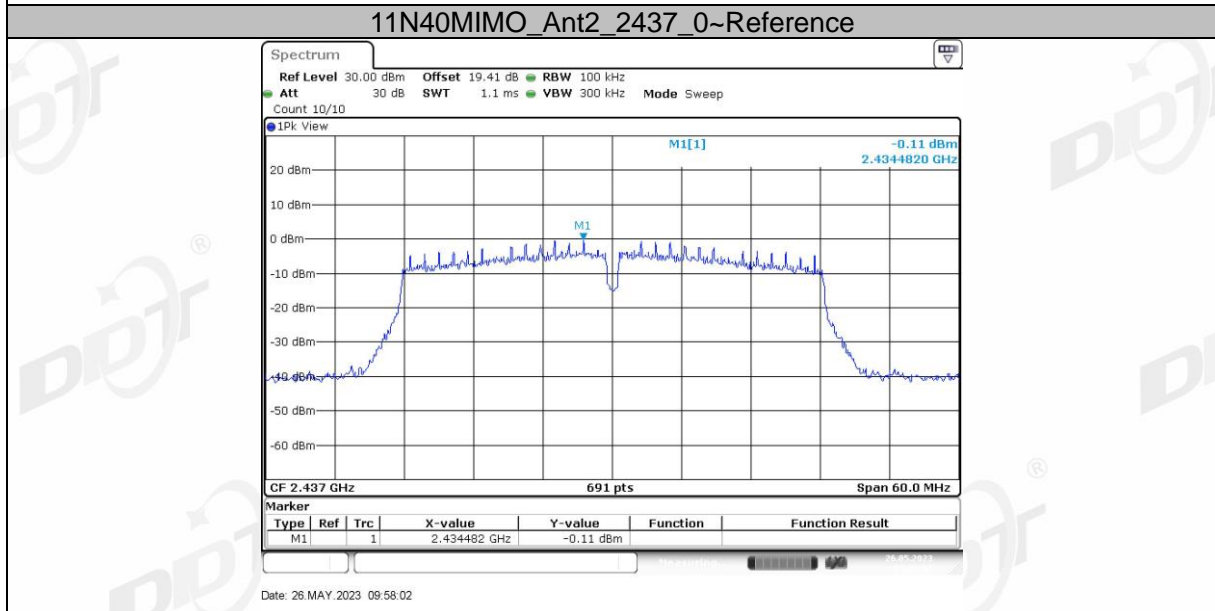
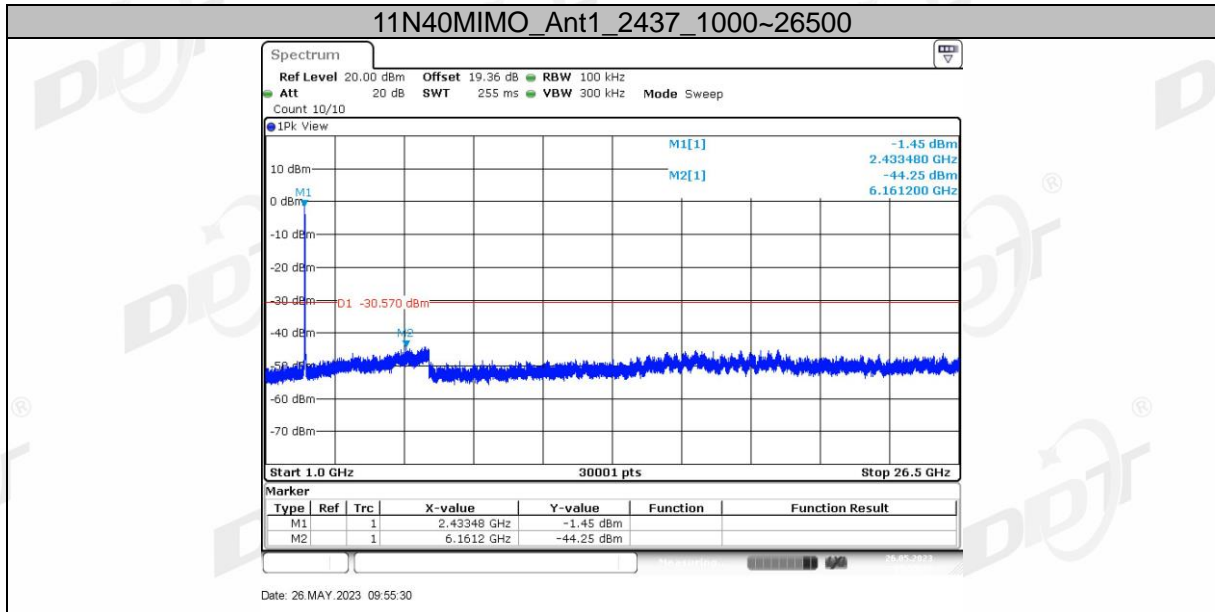

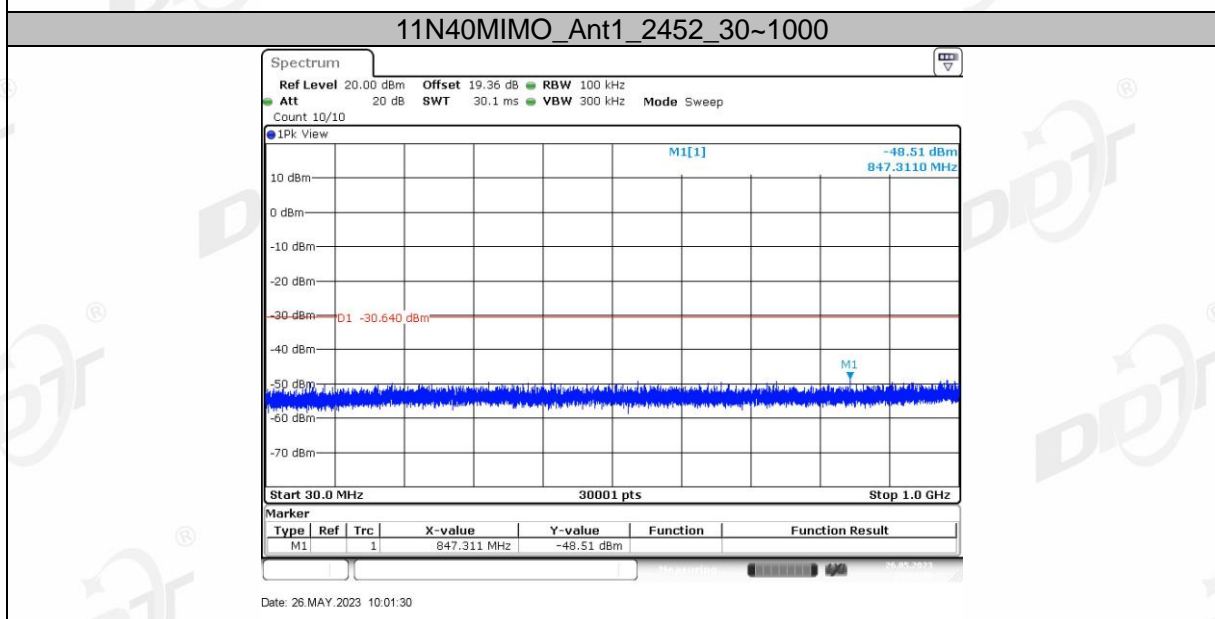
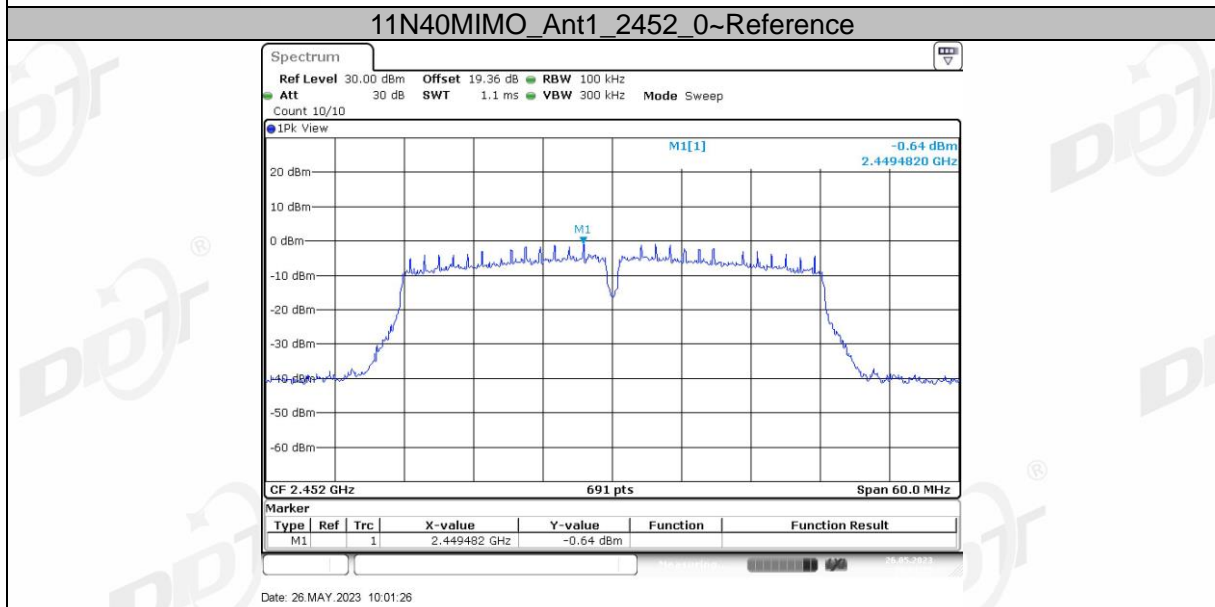
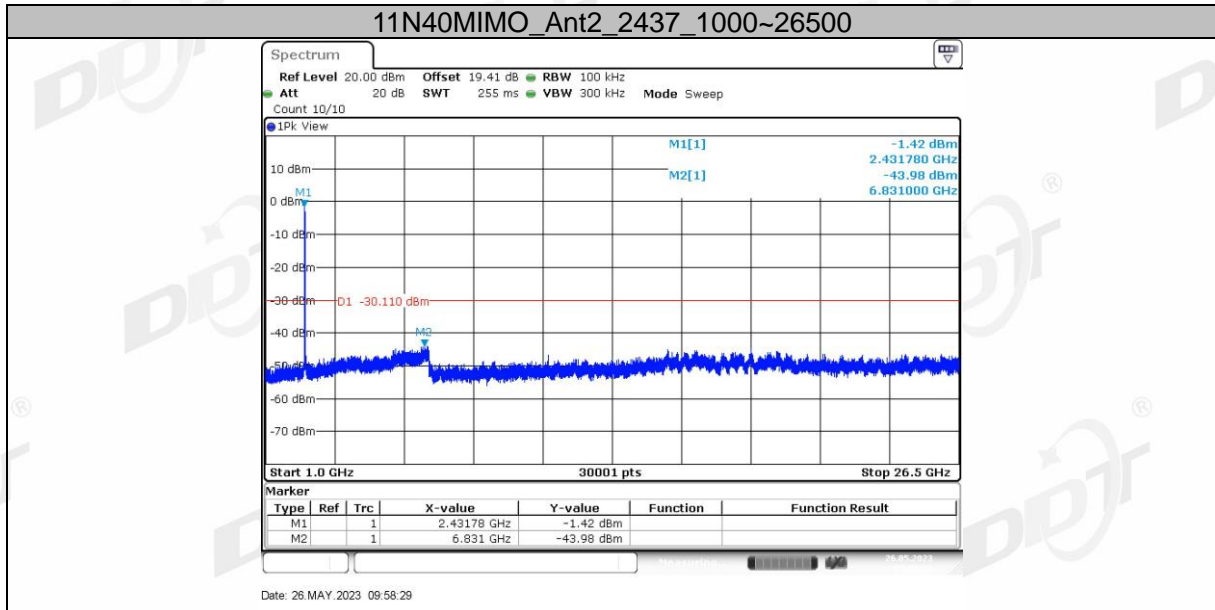

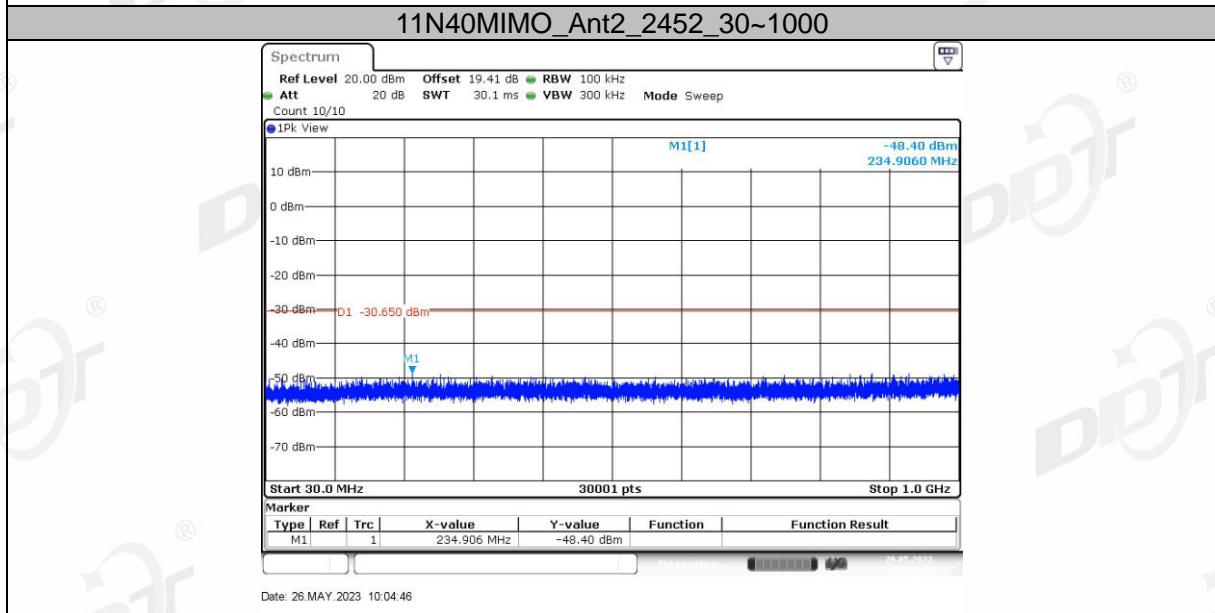
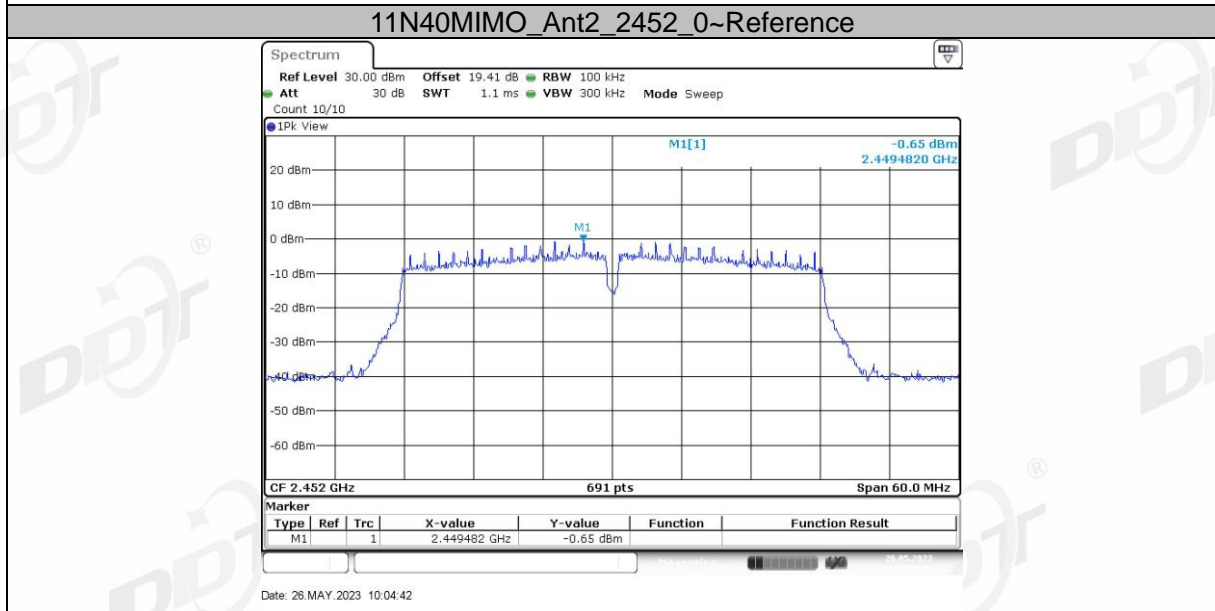
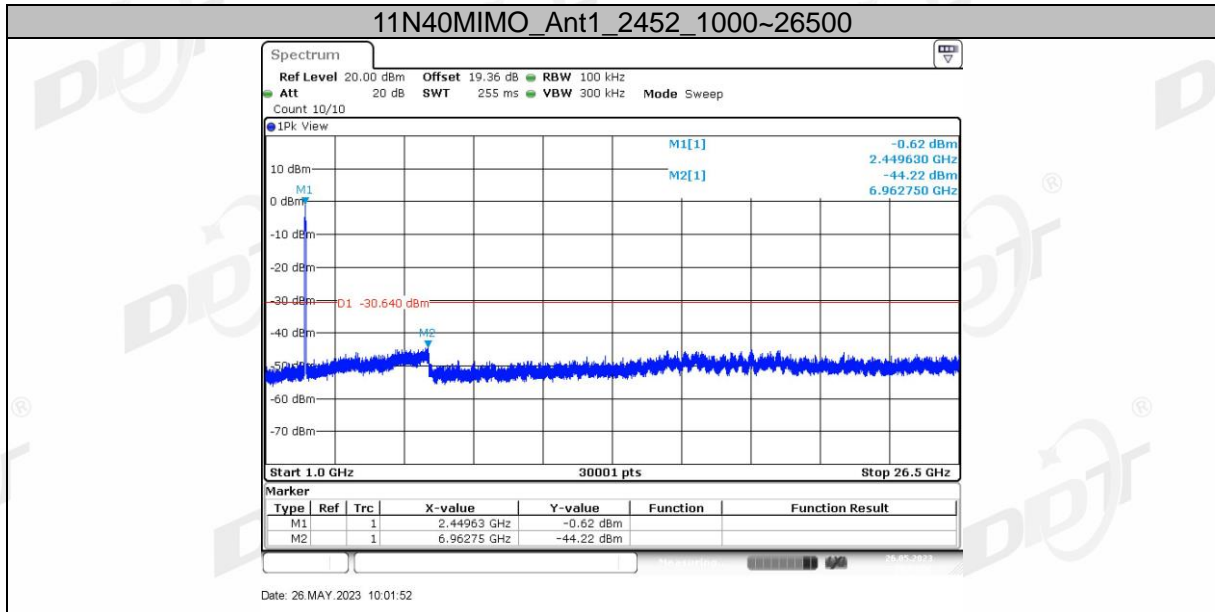

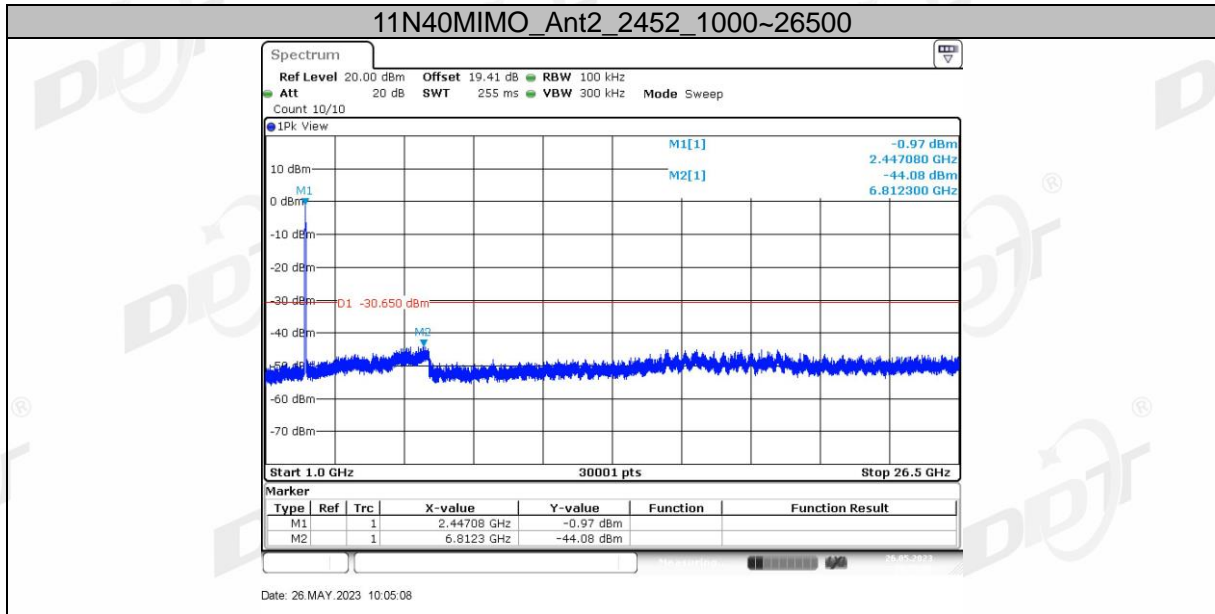

11. Duty Cycle

11.1. Block diagram of test setup

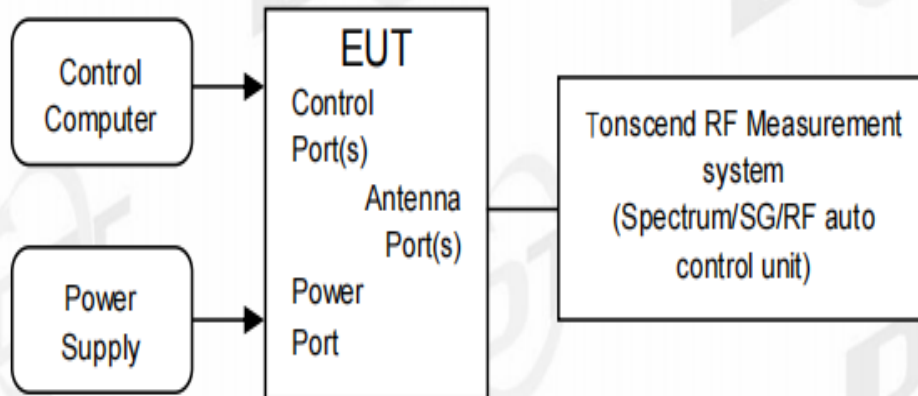

11.2. Limit

Just for Report.

11.3. Test procedure

(1) Connected the EUT's antenna port to the Spectrum Analyzer by suitable attenuator, The cable loss and attenuator loss have been put into spectrum analyzer as amplitude offset.

(2) set the Spectrum Analyzer as below:

Centre Frequency: The centre frequency of the middle hopping channel.

Resolution BW: 10 MHz.

Video BW: 10 MHz.

Span: Zero span.

Detector: Peak.

Trace Mode: Max Hold.

Sweep: Video Trigger

(3) When the trace is complete, measure the sending time of 1 burst and the duty cycle of 1 burst cycle.

(4) Calculate dwell time follow below formula:

Duty cycle= Pulse's on time / Burst cycle

11.4. Test result

Test Mode	Antenna	Frequency [MHz]	Transmission Duration [ms]	Transmission Period [ms]	Duty Cycle [%]
11B	Ant1	2412	8.40	8.43	99.64
	Ant2	2412	8.40	8.43	99.64
	Ant1	2437	8.40	8.43	99.64
	Ant2	2437	8.40	8.43	99.64
	Ant1	2462	8.40	8.43	99.64
	Ant2	2462	8.38	8.43	99.41
11G	Ant1	2412	1.40	1.44	97.22
	Ant2	2412	1.39	1.44	96.53
	Ant1	2437	1.39	1.43	97.20
	Ant2	2437	1.39	1.44	96.53
	Ant1	2462	1.40	1.44	97.22
	Ant2	2462	1.39	1.43	97.20
11N20MIMO	Ant1	2412	0.67	0.72	93.06
	Ant2	2412	0.67	0.71	94.37
	Ant1	2437	0.67	0.71	94.37
	Ant2	2437	0.67	0.72	93.06
	Ant1	2462	0.67	0.72	93.06
	Ant2	2462	0.67	0.72	93.06
11N40MIMO	Ant1	2422	0.35	0.39	89.74
	Ant2	2422	0.34	0.39	87.18
	Ant1	2437	0.35	0.39	89.74
	Ant2	2437	0.34	0.39	87.18
	Ant1	2452	0.34	0.39	87.18
	Ant2	2452	0.34	0.39	87.18