

FCC AND ISED CERTIFICATION TEST REPORT

FOR

Applicant	:	Formovie (Chongqing) Innovative Technology Co., Ltd.
Address	:	4-401, #2 Longgang Road, Guojiatuo Area, Jiangbei District, Chongqing, China
Equipment under Test	:	LCD Smart Projector
Model No.	:	XMM2101, XMM21**(*=0-9)
Trade Mark	:	Xming, WEWATCH
FCC ID	:	2AZNP-XMM2101
IC	:	27267-XMM2101
Manufacturer	:	Formovie (Chongqing) Innovative Technology Co., Ltd.
Address	:	4-401, #2 Longgang Road, Guojiatuo Area, Jiangbei District, Chongqing, China

Issued By: Dongguan Dongdian Testing Service Co., Ltd.

Add.: No. 17, Zongbu Road 2, Songshan Lake Sci&Tech, Industry Park,
Dongguan City, Guangdong Province, China, 523808

Tel.: +86-0769-38826678, **E-mail:** ddt@dgddt.com, <http://www.dgddt.com>

REPORT

Table of Contents

	Test report declares.....	4
1.	Summary of Test Results.....	6
2.	General Test Information	7
2.1.	Description of EUT	7
2.2.	Accessories of EUT.....	8
2.3.	Assistant equipment used for test.....	8
2.4.	Block diagram of EUT configuration for test	8
2.5.	Test environment conditions	8
2.6.	Deviations of test standard.....	9
2.7.	Test laboratory	9
2.8.	Measurement uncertainty.....	9
3.	Equipment Used During Test.....	10
4.	6 dB Bandwidth	12
4.1.	Block diagram of test setup.....	12
4.2.	Limits	12
4.3.	Test procedure	12
4.4.	Test result.....	12
4.5.	Original test data	13
5.	99% Bandwidth	15
5.1.	Block diagram of test setup.....	15
5.2.	Limits	15
5.3.	Test procedure	15
5.4.	Test Result	15
5.5.	Test Graphs.....	16
6.	Maximum Peak Output Power	18
6.1.	Block diagram of test setup.....	18
6.2.	Limits	18
6.3.	Test procedure	18
6.4.	Test result.....	18
6.5.	Original test data	19
7.	Power Spectral Density.....	21
7.1.	Block diagram of test setup.....	21
7.2.	Limits	21
7.3.	Test procedure	21
7.4.	Test result.....	21
7.5.	Test graphs	22
8.	Band Edge Compliance (Conducted Method)	24

8.1.	Block diagram of test setup.....	24
8.2.	Limits	24
8.3.	Test procedure	24
8.4.	Test result.....	25
8.5.	Test graphs	25
9.	Radiated Emission	27
9.1.	Block diagram of test setup.....	27
9.2.	Limit.....	28
9.3.	Test Procedure.....	30
9.4.	Test result.....	31
10.	RF Conducted Spurious Emissions	48
10.1.	Block diagram of test setup.....	48
10.2.	Limits	48
10.3.	Test procedure	48
10.4.	Test result.....	49
10.5.	Test graphs	49
11.	Duty Cycle	56
11.1.	Block diagram of test setup.....	56
11.2.	Limit.....	56
11.3.	Test procedure	56
11.4.	Test result.....	56
11.5.	Test graphs	57
12.	Emissions in Restricted Frequency Bands	59
12.1.	Block diagram of test setup.....	59
12.2.	Limit.....	59
12.3.	Test procedure	59
12.4.	Test result.....	59
13.	Power Line Conducted Emission	68
13.1.	Block diagram of test setup.....	68
13.2.	Power line conducted emission limits	68
13.3.	Test procedure	68
13.4.	Test result.....	69
14.	Antenna Requirements	74
14.1.	Limit.....	74
14.2.	Result	74
15.	Test Setup Photograph	75
16.	Photos of the EUT	77

Test Report Declare

Applicant	:	Formovie (Chongqing) Innovative Technology Co., Ltd.
Address	:	4-401, #2 Longgang Road, Guojiatuo Area, Jiangbei District, Chongqing, China
Equipment under Test	:	LCD Smart Projector
Model No.	:	XMM2101, XMM21**(=-0-9)
Trade Mark	:	Xming, WEWATCH
Manufacturer	:	Formovie (Chongqing) Innovative Technology Co., Ltd.
Address	:	4-401, #2 Longgang Road, Guojiatuo Area, Jiangbei District, Chongqing, China

Test Standard Used:

FCC Rules and Regulations Part 15 Subpart C, RSS-247 Issue 2 February 2017.

Test Procedure Used:

ANSI C63.10:2013, RSS-Gen Issue 5, Apr. 2018, Amendment 2 (February 2021).

We Declare:

The equipment described above is tested by Dongguan Dongdian Testing Service Co., Ltd. and in the configuration tested the equipment complied with the standards specified above. The test results are contained in this test report and Dongguan Dongdian Testing Service Co., Ltd. is assumed of full responsibility for the accuracy and completeness of these tests.

After test and evaluation, our opinion is that the equipment provided for test compliance with the requirement of the above FCC&ISED standards.

Report No.:	DDT-RE23042304-2E02		
Date of Receipt:	May 08, 2023	Date of Test:	May 10, 2023~ May 28, 2023

Prepared By:

Jacky Huang

Jacky Huang/Engineer

Approved By:



Damon Hu/EMC Manager

Note: This report applies to above tested sample only. This report shall not be reproduced in parts without written approval of Dongguan Dongdian Testing Service Co., Ltd.

Revision History

Rev.	Revisions	Issue Date	Revised By
---	Initial issue	Jun. 02, 2023	

1. Summary of Test Results

Description of Test Item	Standard	Results
6 dB Bandwidth and 99% Bandwidth	FCC Part 15: 15.247 ANSI C63.10:2013 RSS-247 Issue 2 RSS-Gen 6.7	Pass
Peak Output Power	FCC Part 15: 15.247 ANSI C63.10:2013 RSS-247 Issue 2	Pass
Power Spectral Density	FCC Part 15:15.247 ANSI C63.10:2013 RSS-247 Issue 2	Pass
Band Edge Compliance (Conducted Method)	FCC Part 15: 15.209 FCC Part 15: 15.247 ANSI C63.10: 2013 RSS-247 Issue 2 RSS-Gen Issue 5	Pass
Radiation Emission	FCC Part 15: 15.247 ANSI C63.10:2013 RSS-247 Issue 2 RSS-Gen Issue 5	Pass
RF Conducted Spurious Emissions	FCC Part 15: 15.209 FCC Part 15: 15.247 ANSI C63.10: 2013 RSS-247 Issue 2 RSS-Gen Issue 5	Pass
Emission in Restricted Frequency Bands	FCC Part 15: 15.209 FCC Part 15: 15.247 ANSI C63.10: 2013 RSS-247 Issue 2 RSS-Gen Issue 5	Pass
Power Line Conducted Emission	FCC Part 15: 15.207 ANSI C63.10: 2013 RSS-Gen Issue 5	Pass
Antenna Requirement	FCC Part 15: 15.203 RSS-Gen Issue 5	Pass

2. General Test Information

2.1. Description of EUT

EUT Name	: LCD Smart Projector
Model Number	: XMM2101, XMM21**(*=0-9)
Model Differences	: The models used are the same in appearance, process material, hardware and software, just different model for different market or business purposes, therefore was tested on the model XMM2101.
EUT Function Description	: Please reference user manual of this device
Power Supply	: DC 19V from external switching power supply
Radio Specification	: Bluetooth V5.0
Operation Frequency	: 2402 MHz - 2480 MHz
Modulation	: GFSK
Data Rate	: 1 Mbps, 2 Mbps
Antenna	: FPC antenna, maximum PK gain: 3.82 dBi
Sample Number	: S23042304-01

Note: Serial model No.: XMM21** only apply for FCC ID.

Channel information					
Channel	Frequency (MHz)	Channel	Frequency (MHz)	Channel	Frequency (MHz)
0	2402	14	2430	28	2458
1	2404	15	2432	29	2460
2	2406	16	2434	30	2462
3	2408	17	2436	31	2464
4	2410	18	2438	32	2466
5	2412	19	2440	33	2468
6	2414	20	2442	34	2470
7	2416	21	2444	35	2472
8	2418	22	2446	36	2474
9	2420	23	2448	37	2476
10	2422	24	2450	38	2478
11	2424	25	2452	39	2480
12	2426	26	2454		
13	2428	27	2456		

2.2. Accessories of EUT

Description of Accessories	Manufacturer	Model Number	Description	Remark
Switching power supply	Huizhou Golden Lake Industrial Co., Ltd.	S065ARU20003 25	N/A	Input: 100-240V~, 50/60Hz, 1.8A MAX Output: 5V/3A, 9V/3A, 12V/3A, 15V/3A, 20V/3.25A
Bluetooth Remote Control	Formovie (Chongqing) Innovative Technology Co., Ltd.	RC605B	N/A	N/A

2.3. Assistant equipment used for test

Assistant equipment	Manufacturer	Model number	EMC Compliance	SN
N/A	N/A	N/A	N/A	N/A

2.4. Block diagram of EUT configuration for test



Test software: putty.exe

The test software was used to control EUT work in Continuous Tx mode, and select test channel, wireless mode as below table.

The pathloss of external cable: 0.5dB (According to the manufacturer's claims).

Tested mode, channel, information			
Mode	Setting Tx Power	Channel	Frequency (MHz)
GFSK 1M	default	CH0	2402
	default	CH19	2440
	default	CH39	2480

2.5. Test environment conditions

During the measurement the environmental conditions were within the listed ranges:

Temperature range:	+15 °C to +35 °C
Humidity range:	20% to 75%
Pressure range:	86 kPa to 106 kPa

2.6. Deviations of test standard

No deviation.

2.7. Test laboratory

Dongguan Dongdian Testing Service Co., Ltd.

Add.: No. 17, Zongbu Road 2, Songshan Lake Sci&Tech, Industry Park, Dongguan City, Guangdong Province, China, 523808.

Tel.: +86-0769-38826678, <http://www.dgddt.com>, Email: ddt@dgddt.com.

CNAS Accreditation No. L6451; A2LA Accreditation Number: 3870.01

FCC Designation Number: CN1182, Test Firm Registration Number: 540522

Innovation, Science and Economic Development Canada Site Registration Number: 10288A

Conformity Assessment Body identifier: CN0048

VCCI facility registration number: C-20087, T-20088, R-20123, R-20155, G-20118

2.8. Measurement uncertainty

Test Item	Uncertainty
Bandwidth	1.1%
Peak Output Power (Conducted) (Spectrum Analyzer)	0.86 dB (10 MHz ≤ f < 3.6 GHz); 1.38 dB (3.6 GHz ≤ f < 8 GHz)
Peak Output Power (Conducted) (Power Sensor)	0.74 dB
Power Spectral Density	0.74 dB (10 MHz ≤ f < 3.6 GHz); 1.38 dB (3.6 GHz ≤ f < 8 GHz)
Frequencies Stability	6.7 x 10 ⁻⁸ (Antenna couple method) 5.5 x 10 ⁻⁸ (Conducted method)
Conducted Spurious Emissions	0.86 dB (10 MHz ≤ f < 3.6 GHz); 1.40 dB (3.6 GHz ≤ f < 8 GHz) 1.66 dB (8 GHz ≤ f < 26.5 GHz)
Uncertainty for Radio Frequency (RBW<20 KHz)	3x10 ⁻⁸
Temperature	0.4 °C
Humidity	2 %
Uncertainty for Radiation Emission Test (9khz -30 Mhz)	3.44 dB
Uncertainty for Radiation Emission Test (30 Mhz-1 Ghz)	4.70 dB (Antenna Polarize: V) 4.84 dB (Antenna Polarize: H)
Uncertainty for Radiation Emission Test (1 Ghz-40 Ghz)	4.10 dB (1-6 GHz) 4.40 dB (6 GHz-18 GHz) 3.54 dB (18 GHz-26 GHz) 4.30 dB (26 GHz-40 GHz)
Uncertainty for Power Line Conduction Emission Test	3.32 dB (150 kHz-30 MHz)

Note: This uncertainty represents an expanded uncertainty expressed at approximately the 95% confidence level using a coverage factor of k=2.

3. Equipment Used During Test

Equipment	Manufacturer	Model No.	Serial No.	Last Cal.	Cal. Interval
☑RF Connected Test (Tonscend RF Measurement System 3#)					
Signal & Spectrum analyzer	R&S	FSV40	101407	Jul. 21, 2022	1 Year
Wideband Radio Communication tester	R&S	CMW500	117491	Apr. 27, 2023	1 Year
EXG Analog Signal Generator	KEYSIGHT	N5173B	MY62153058	Aug. 26, 2022	1 Year
Vector Signal Generator	Agilent	N5182A	MY48180912	Apr. 23, 2023	1 Year
RF Control Unit	Tonscend	JS0806-2	20C8060230	Apr. 27, 2023	1 Year
Temp&Humi Programmable	ZHIXIANG	ZXGDJS-150L	ZX170110-A	May 15, 2023	1 Year
Test Software	JS Tonscend	JS1120-3	Ver.3.2.22	N/A	N/A
☑Radiation 3#chamber					
EMI Test Receiver	R&S	ESU26	100472	Apr. 23, 2023	1 Year
Spectrum analyzer	Agilent	E4447A	MY50180031	Apr. 23, 2023	1 Year
Active Loop antenna	Schwarzbeck	FMZB-1519	1519-038	Sep. 29, 2022	1 Year
Trilog Broadband Antenna	Schwarzbeck	VULB 9163	01429	Jul. 22, 2022	1 Year
Double Ridged Horn Antenna	Schwarzbeck	BBHA9120 D	02468	Sep. 29, 2022	1 Year
Broad Band Horn Antenna	Schwarzbeck	BBHA 9170	790	Apr. 26, 2023	1 Year
Pre-amplifier	SONOMA	310N	310815	Jun. 15, 2022	1 Year
Pre-amplifier	COM-POWER	PAM-118A	18040084	Aug.17, 2022	1 Year
Pre-amplifier	COM-POWER	PAM-840A	461369	Apr. 27, 2023	1 Year
RE Cable	N/A	W23.02 CP1-X2 + W23.09 AP1-X8+ JCT26S-NJ-NJ-1.5M+ JCT26S-NJ-NJ-1.5M	4.5M+8M+1.5M+1.5M	Apr. 21, 2023	1 Year
RF Cable	Yuhu Technology	JCTB810-NJ-NJ -9M+ ZT26S-SMAJ-SMAJ-1M	21123964	Apr. 23, 2023	1 Year
Micro-Tronics filters	REBES	BRM50702	G555	N/A	N/A
Micro-Tronics filters	REBES	BRM50716	G392	N/A	N/A
High Pass filter	XB	XBLBQ-GTA67	210820-2-3	N/A	N/A
Test software	Tonscend	JS32-RE	V 5.0.0.1	N/A	N/A

<input checked="" type="checkbox"/> Power Line Conducted Emissions Test 1#					
Test Receiver	R&S	ESCI	100551	Aug. 26, 2022	1 Year
LISN 1	R&S	ENV216	101109	Aug. 26, 2022	1 Year
LISN 2	R&S	ESH2-Z5	100309	Aug. 26, 2022	1 Year
Pulse Limiter	R&S	ESH3-Z2	101242	Aug. 26, 2022	1 Year
CE Cable 1	HUBSER	N/A	W10.01	Aug. 26, 2022	1 Year
Test software	Audix	E3	V 6.11111b	N/A	N/A
Test Receiver	R&S	ESCI	100551	Aug. 26, 2022	1 Year

4. 6 dB Bandwidth

4.1. Block diagram of test setup

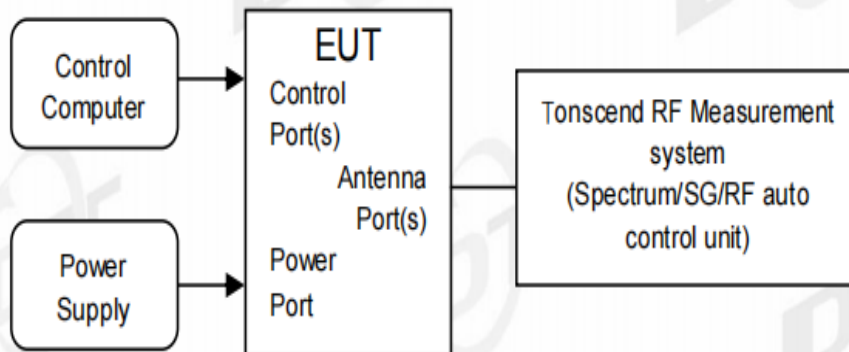

4.2. Limits

For direct sequence systems, the minimum 6 dB bandwidth shall be at least 500 kHz

4.3. Test procedure

- (1) The test according to ANSI C63.10-2013 clause 11.8.
- (2) Connect EUT's antenna output to spectrum analyzer by RF cable, the path loss was compensated to the results
- (3) Set the EUT as maximum power setting and enable the EUT transmit continuously
- (4) Use the following spectrum analyzer settings for 6 dB Bandwidth:

RBW:	100 kHz
VBW:	$\geq [3 \times \text{RBW}]$
Detector Mode:	Peak
Sweep time:	auto
Trace mode	Max hold

- (5) Allow the trace to stabilize, measure the 6 dB bandwidth of signal, and record the results in the report.

4.4. Test result

Test Mode	Antenna	Frequency [MHz]	DTS BW [MHz]	FL [MHz]	FH [MHz]	Limit [MHz]	Verdict
BLE_1M	Ant1	2402	0.69	2401.64	2402.33	0.5	PASS
		2440	0.69	2439.64	2440.33	0.5	PASS
		2480	0.69	2479.64	2480.33	0.5	PASS
BLE_2M	Ant1	2402	1.24	2401.35	2402.58	0.5	PASS
		2440	1.23	2439.35	2440.58	0.5	PASS
		2480	1.24	2479.35	2480.58	0.5	PASS

4.5. Original test data

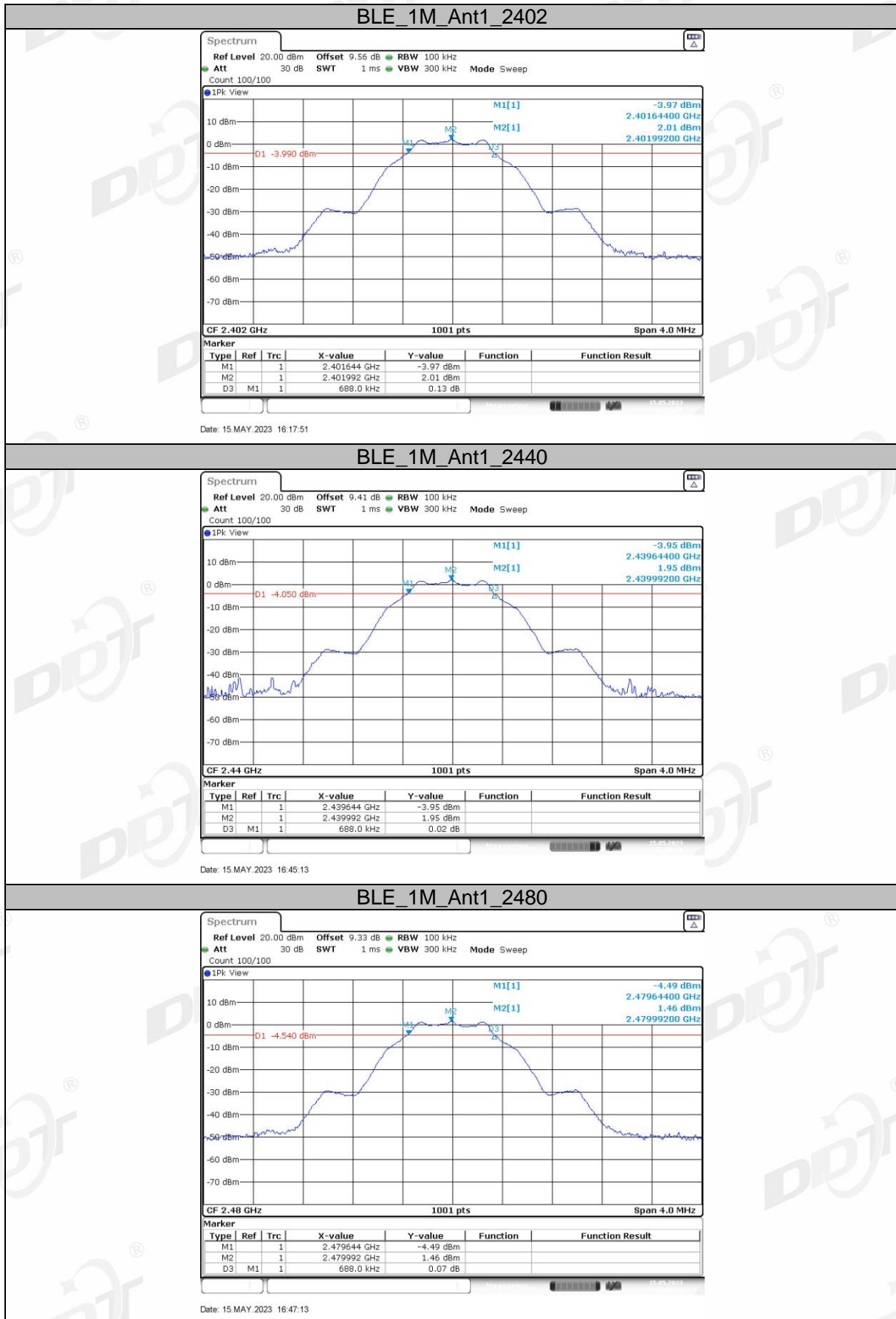

BLE_2M_Ant1_2402

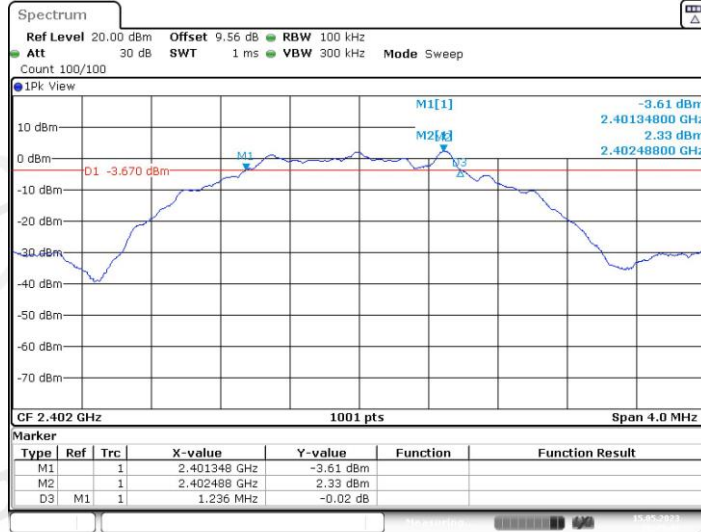

Date: 15.MAY.2023 16:49:47

BLE_2M_Ant1_2440

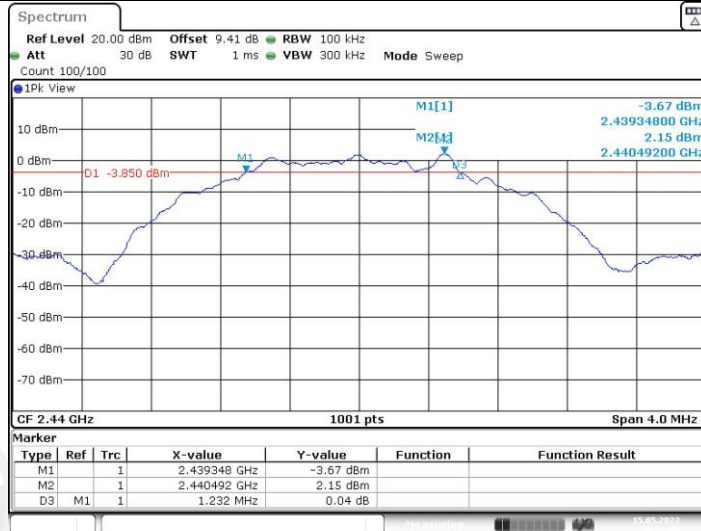

Date: 15.MAY.2023 16:52:00

BLE_2M_Ant1_2480

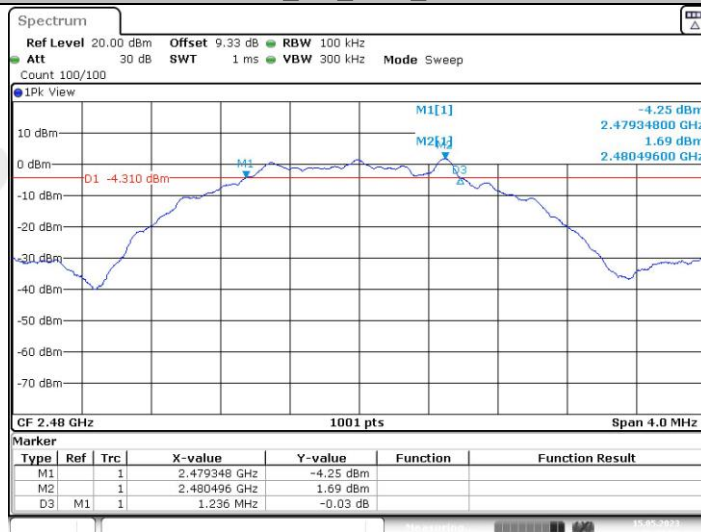

Date: 15.MAY.2023 16:53:53

5. 99% Bandwidth

5.1. Block diagram of test setup

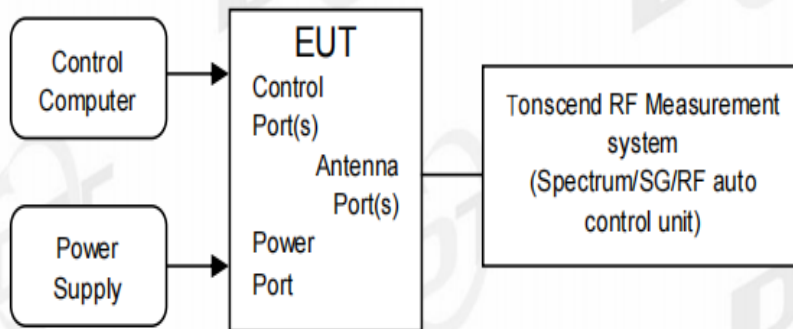

5.2. Limits

Just for Report.

5.3. Test procedure

- (1) The test according to ANSI C63.10-2013 clause 6.9.3.
- (2) Connect EUT's antenna output to spectrum analyzer by RF cable, the path loss was compensated to the results
- (3) Set the EUT as maximum power setting and enable the EUT transmit continuously
- (4) Use the following spectrum analyzer settings for the 99% Bandwidth:

RBW:	1% to 5% of the OBW
VBW:	approximately three times RBW
Span:	between 1.5 times and 5.0 times the OBW
Detector Mode:	Peak
Sweep time:	Auto
Trace mode	Max hold
- (5) Allow the trace to stabilize, measure the 99% bandwidth of signal, and record the results in the report.

5.4. Test Result

Test Mode	Antenna	Frequency [MHz]	OCB [MHz]	FL [MHz]	FH [MHz]	Limit [MHz]	Verdict
BLE_1M	Ant1	2402	1.043	2401.4765	2402.5195	---	---
		2440	1.043	2439.4765	2440.5195	---	---
		2480	1.043	2479.4765	2480.5195	---	---
BLE_2M	Ant1	2402	2.05	2400.9650	2403.0150	---	---
		2440	2.05	2438.9650	2441.0150	---	---
		2480	2.05	2478.9650	2481.0150	---	---

5.5. Test Graphs



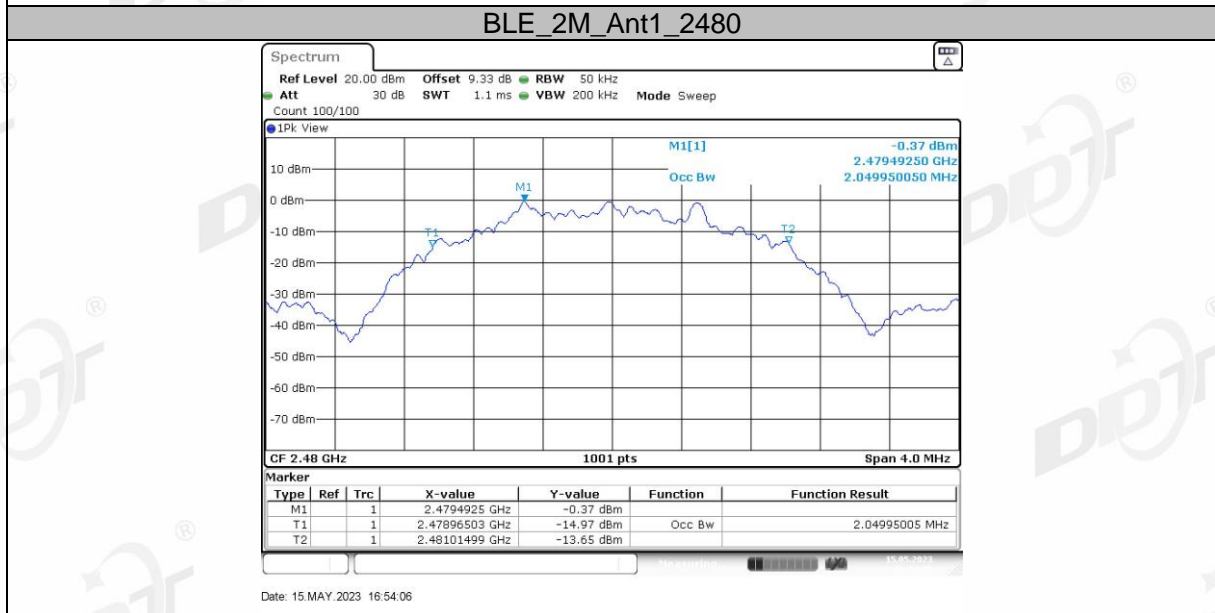
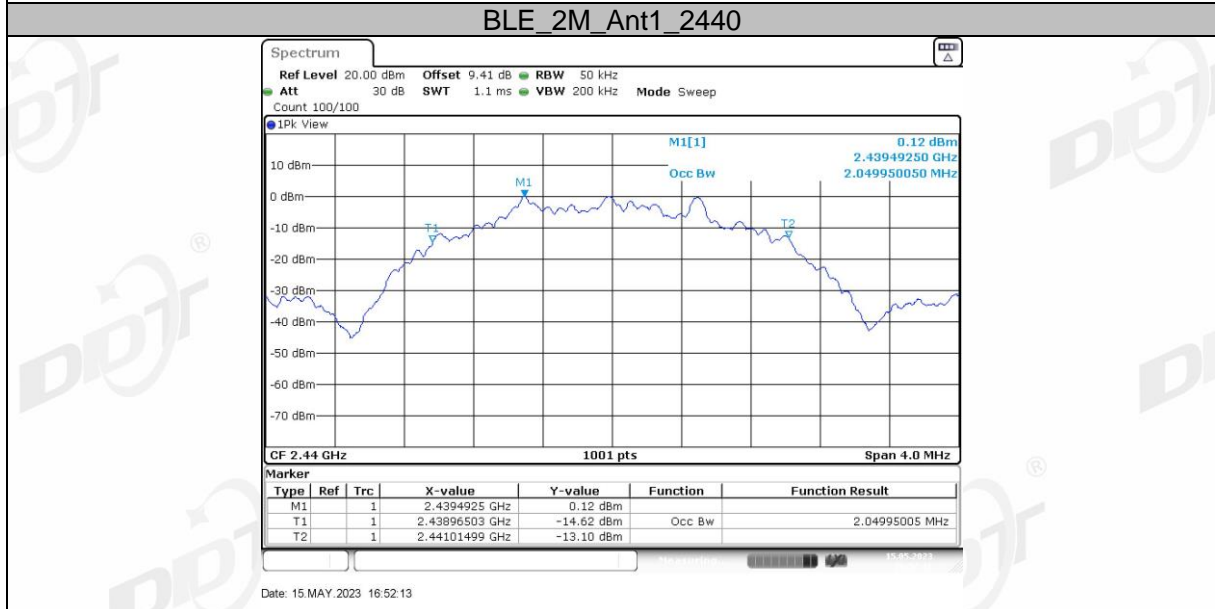
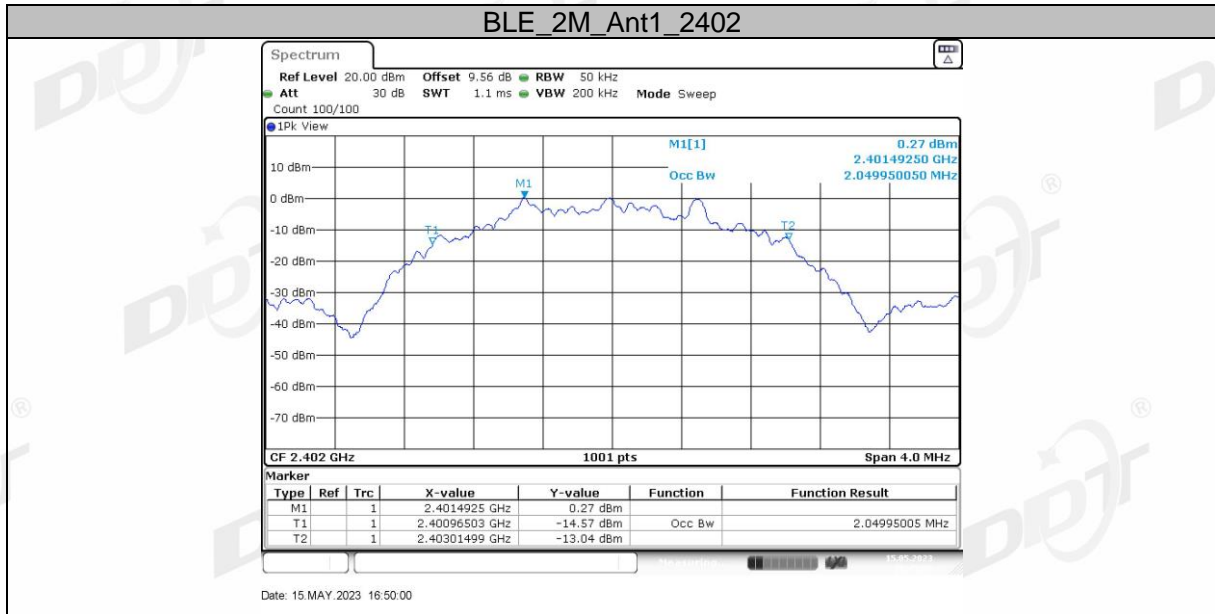

6. Maximum Peak Output Power

6.1. Block diagram of test setup

Same as 5.1.

6.2. Limits

For systems using digital modulation in the 902-928 MHz, 2400-2483.5 MHz, and 5725-5850 MHz bands: 1 Watt. If transmitting antennas of directional gain greater than 6dBi are used, the conducted output power from the intentional radiator shall be reduced below the stated values as appropriate, by the amount in dB that the directional gain of the antenna exceeds 6 dBi, the e.i.r.p shall not exceed 4W.

6.3. Test procedure

- (1) The test according to ANSI C63.10-2013 clause 11.9.1.1.
- (2) Connect EUT's antenna output to spectrum analyzer by RF cable, the path loss was compensated to the results.
- (3) Set the EUT as maximum power setting and enable the EUT transmit continuously.
- (4) Use the following spectrum analyzer settings for the maximum peak output power measurement:

RBW:	≥DTS bandwidth
VBW:	≥3 x RBW
Span	≥3 x RBW
Detector Mode:	Peak
Sweep time:	Auto
Trace mode	Max hold

- (5) Allow the trace to stabilize, use peak marker function to determine the peak amplitude level.

6.4. Test result

Test Mode	Antenna	Frequency [MHz]	Conducted Peak Power [dBm]	Conducted Limit [dBm]	EIRP [dBm]	EIRP Limit [dBm]	Verdict
BLE_1M	Ant1	2402	2.82	≤30	6.64	≤36	PASS
		2440	2.73	≤30	6.55	≤36	PASS
		2480	2.26	≤30	6.08	≤36	PASS
BLE_2M	Ant1	2402	2.86	≤30	6.68	≤36	PASS
		2440	2.72	≤30	6.54	≤36	PASS
		2480	2.24	≤30	6.06	≤36	PASS

6.5. Original test data



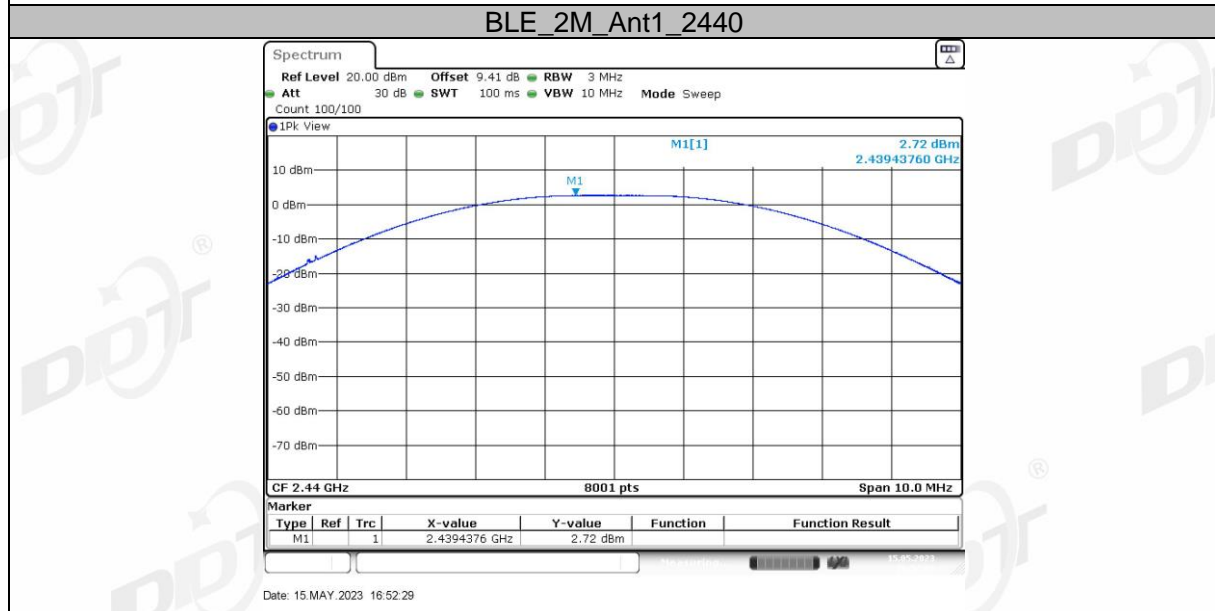
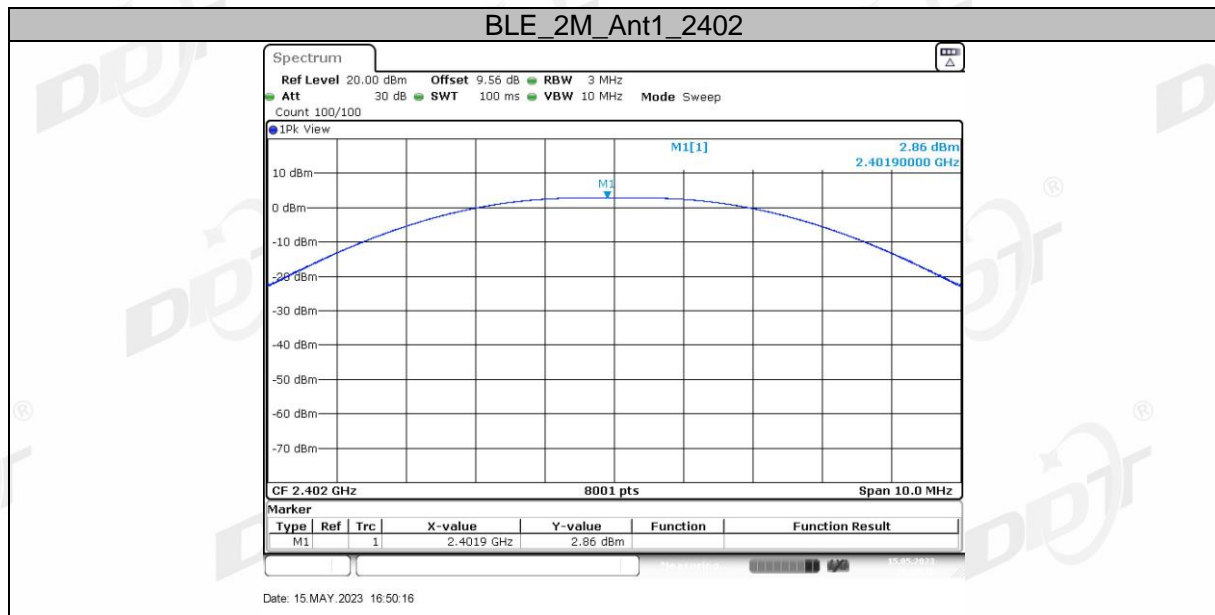

7. Power Spectral Density

7.1. Block diagram of test setup

Same as 5.1.

7.2. Limits

For digitally modulated systems, the power spectral density conducted from the intentional radiator to the antenna shall not be greater than 8 dBm in any 3 kHz band during any time interval of continuous transmission.

7.3. Test procedure

- (1) The test according to ANSI C63.10-2013 clause 11.10.2.
- (2) Connect EUT's antenna output to spectrum analyzer by RF cable, the path loss was compensated to the results.
- (3) Set the EUT as maximum power setting and enable the EUT transmit continuously.
- (4) Use the following spectrum analyzer settings for Power Spectral Density measurement:

Center frequency	DTS Channel center frequency
RBW:	$3 \text{ kHz} \leq \text{RBW} \leq 100 \text{ kHz}$
VBW:	$\geq 3\text{RBW}$
Span	1.5 times the DTS bandwidth
Detector Mode:	Peak
Sweep time:	Auto
Trace mode	Max hold

- (5) Allow the trace to stabilize, use the peak marker function to determine the maximum amplitude level within the RBW.

Note: If measured value exceeds limit, reduce RBW (no less than 3 kHz) and repeat.

7.4. Test result

Test Mode	Antenna	Frequency [MHz]	Result [dBm/3kHz]	Limit [dBm/3kHz]	Verdict
BLE_1M	Ant1	2402	-12.32	≤ 8.00	PASS
		2440	-12.33	≤ 8.00	PASS
		2480	-12.82	≤ 8.00	PASS
BLE_2M	Ant1	2402	-9.67	≤ 8.00	PASS
		2440	-9.74	≤ 8.00	PASS
		2480	-10.23	≤ 8.00	PASS

7.5. Test graphs

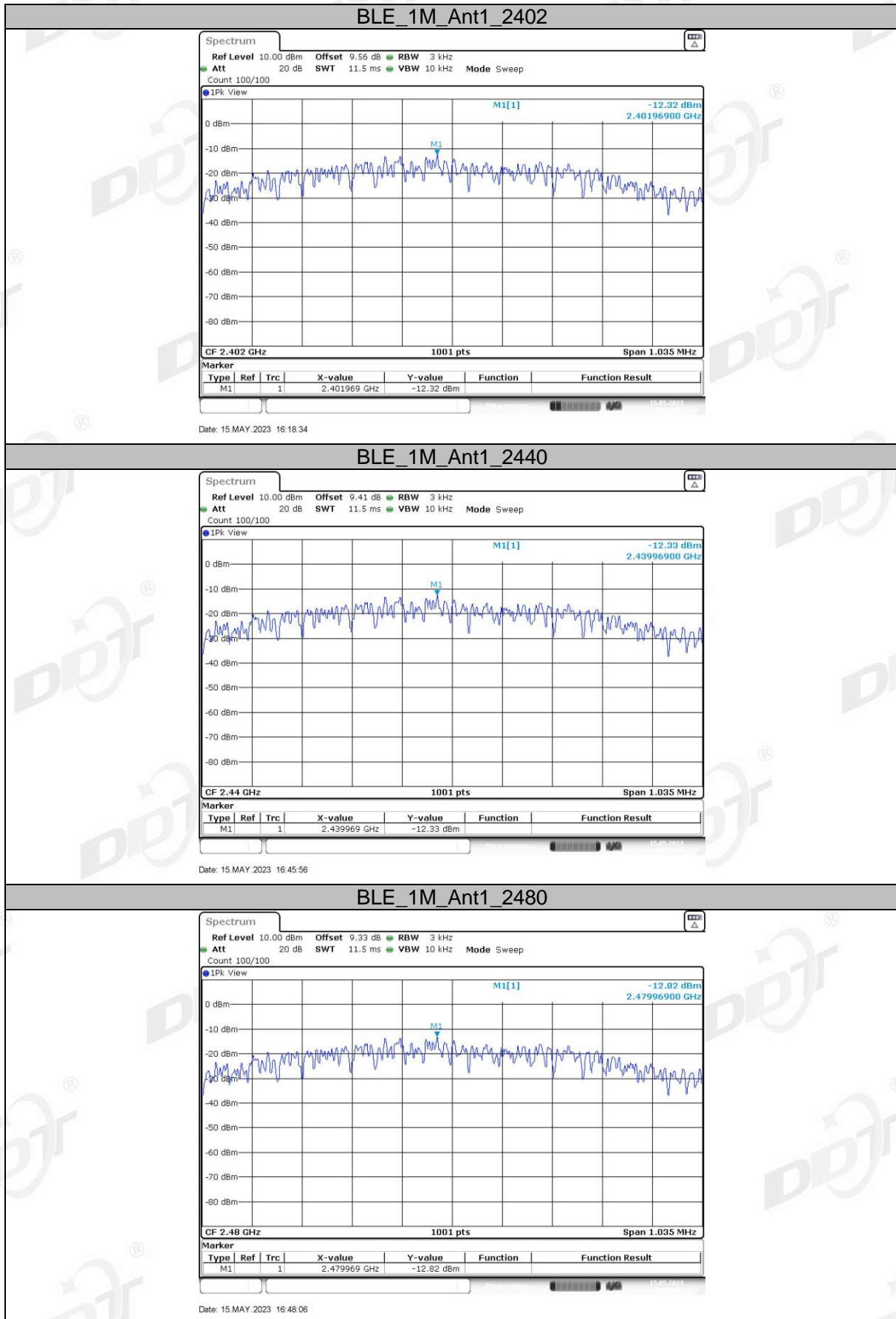

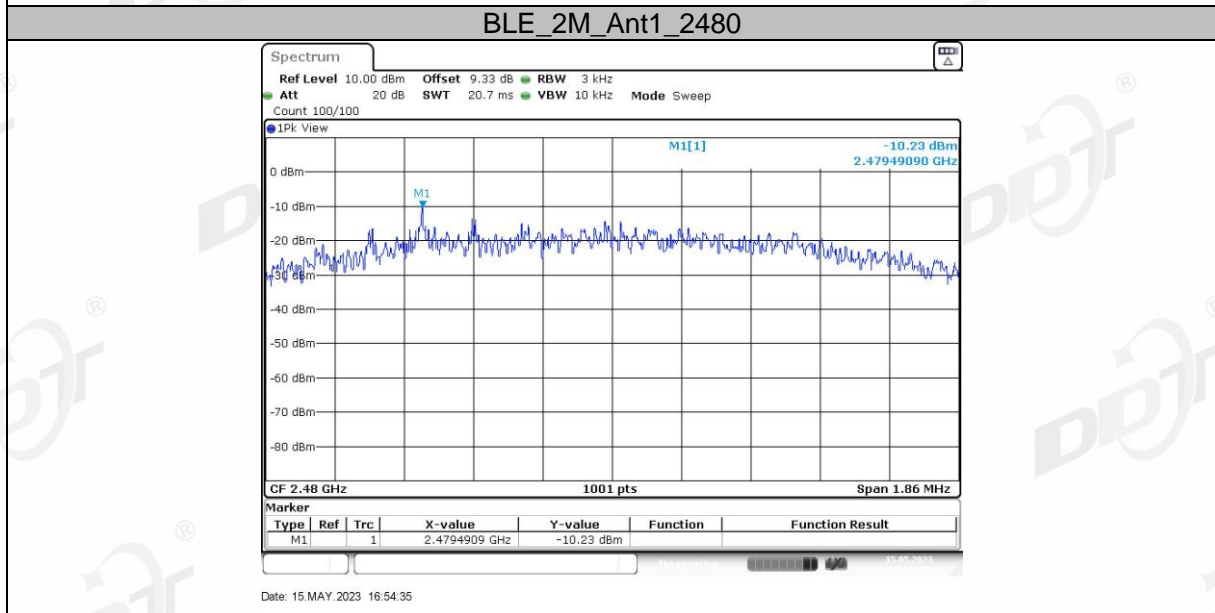
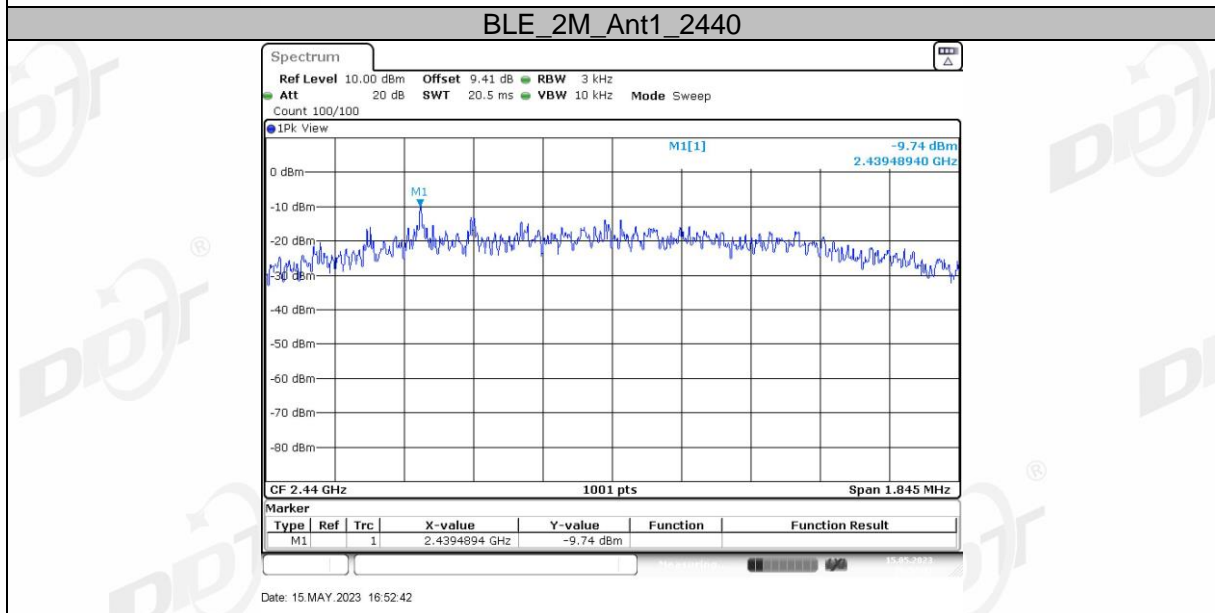
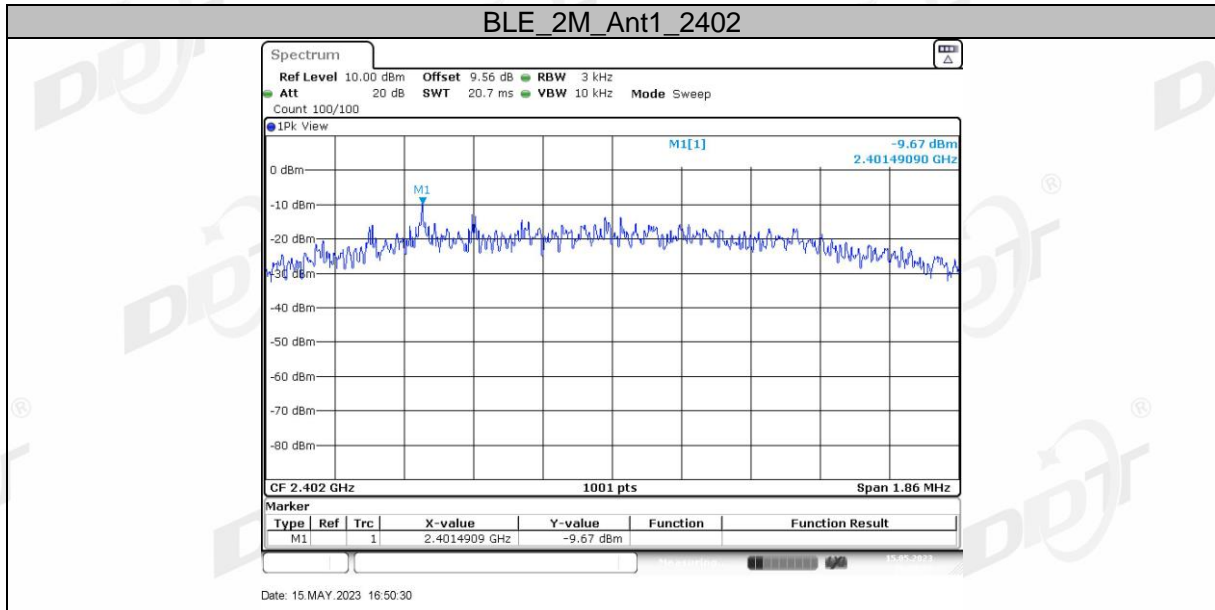

8. Band Edge Compliance (Conducted Method)

8.1. Block diagram of test setup

Same as 5.1.

8.2. Limits

In any 100 kHz bandwidth outside the frequency bands in which the spread spectrum intentional radiator is operating, the radio frequency power that is produced by the intentional radiator shall be at least 20 dB below that in the 100 kHz bandwidth within the band that contains the highest level of the desired power.

8.3. Test procedure

(1) Connect EUT's antenna output to spectrum analyzer by RF cable.

(2) Establish a reference level by using the following procedure:

Center frequency	DTS Channel center frequency
RBW:	100 kHz
VBW:	300 kHz
Span	1.5 times the DTS bandwidth
Detector Mode:	Peak
Sweep time:	Auto
Trace mode	Max hold

(3) Allow the trace to stabilize, use the peak marker function to determine the maximum peak power level to establish the reference level.

(4) Set the spectrum analyzer as follows:

RBW:	100 kHz
VBW:	300 kHz
Span	Encompass frequency range to be measured
Number of measurement points	$\geq \text{span}/\text{RBW}$
Detector Mode:	Peak
Sweep time:	Auto
Trace mode	Max hold

(5) Allow the trace to stabilize, use the peak marker function to determine the maximum amplitude of all unwanted emissions outside of the authorized frequency band.

8.4. Test result

EUT Set Mode	Channel or Frequency	Measured Range	Verdict
BLE_1M	CH0	2.310 GHz - 2.410 GHz	Pass
	CH39	2.470 GHz - 2.500 GHz	Pass
BLE_2M	CH0	2.310 GHz - 2.410 GHz	Pass
	CH39	2.470 GHz - 2.500 GHz	Pass

8.5. Test graphs

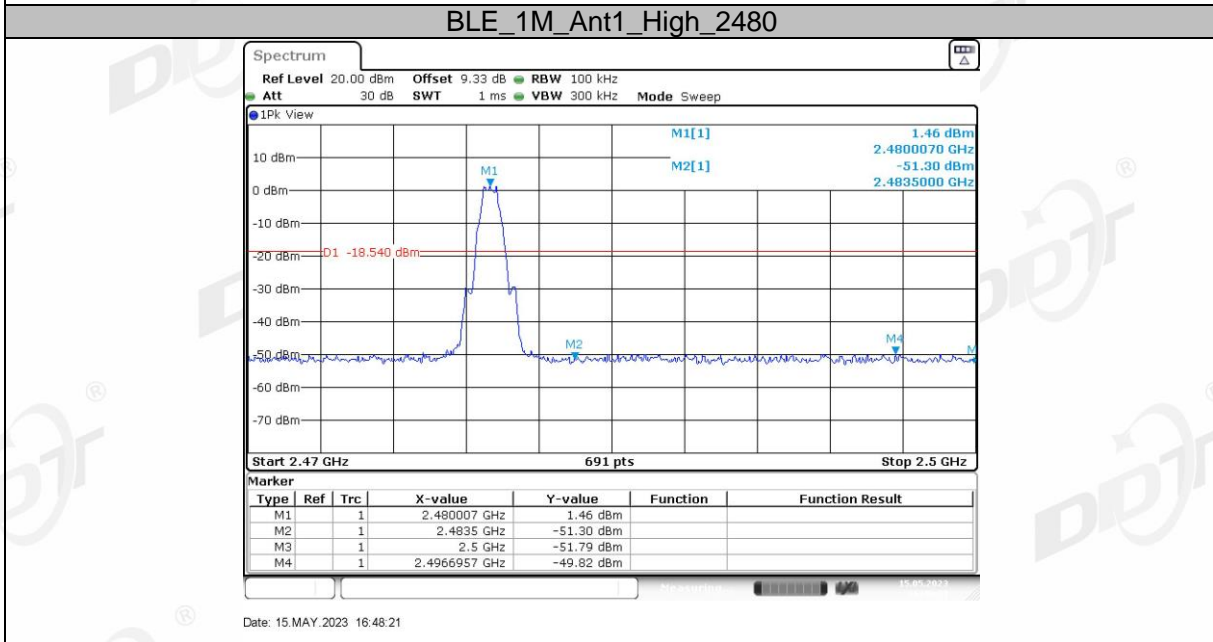
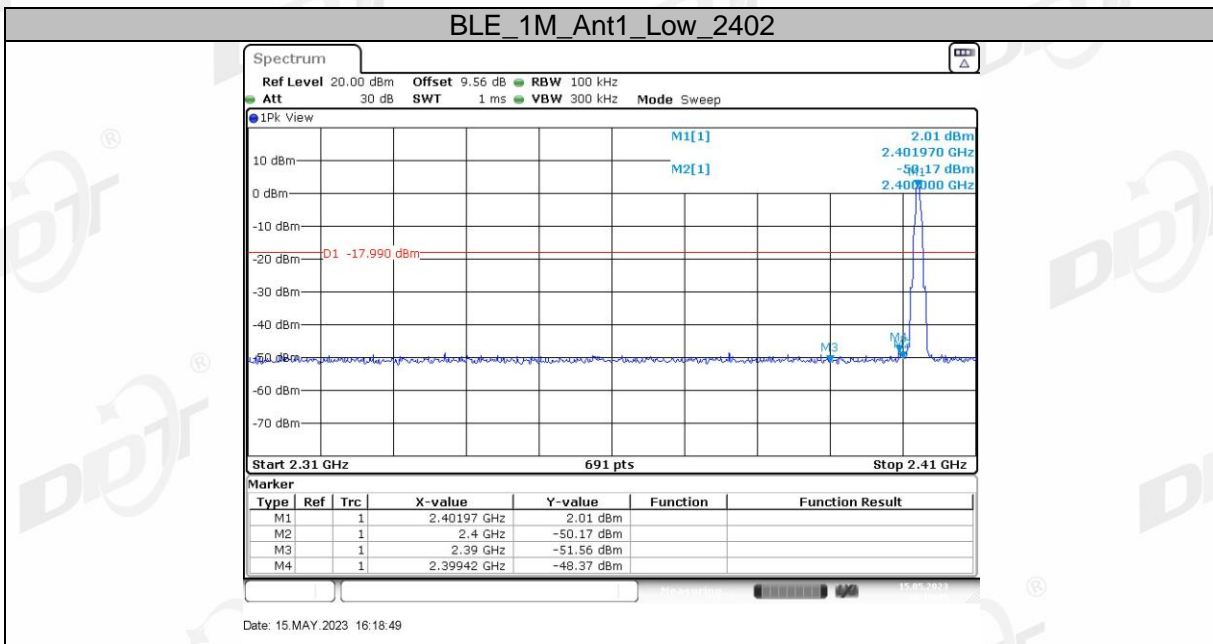

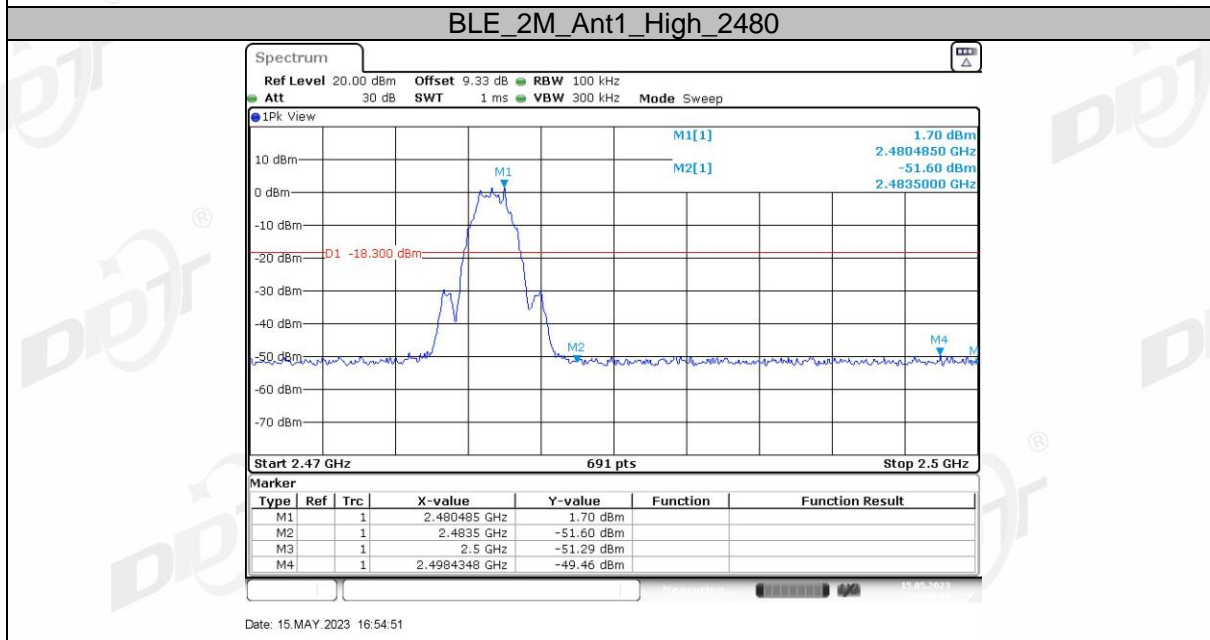
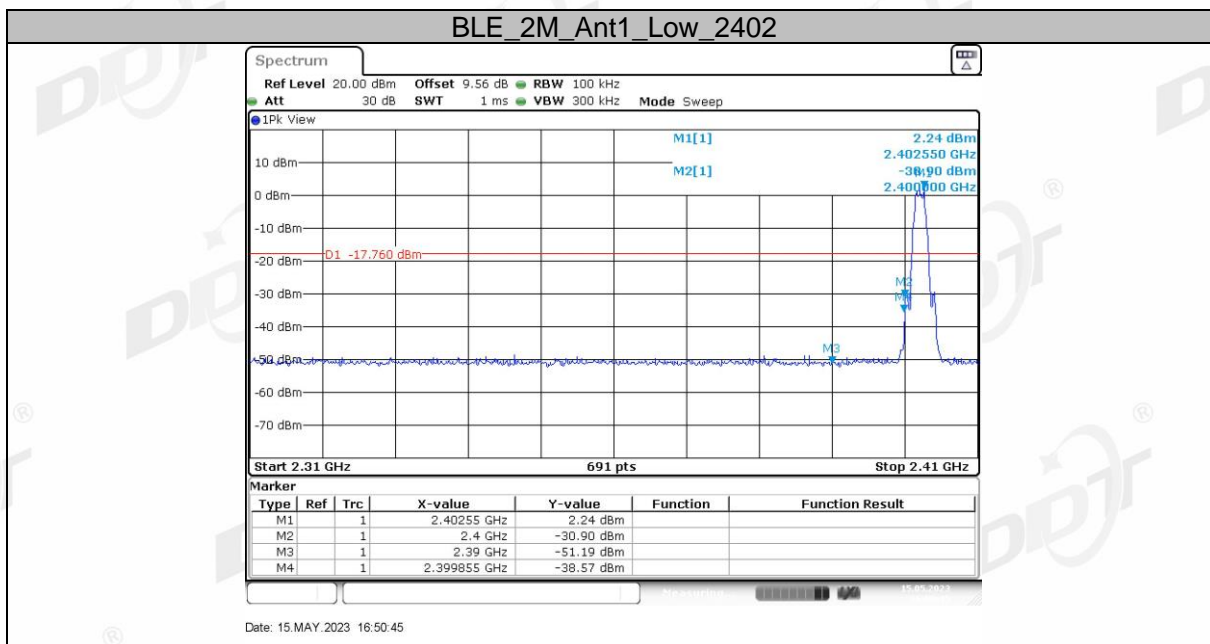

9. Radiated Emission

9.1. Block diagram of test setup

In 3 m Anechoic Chamber, test setup diagram for 9 kHz - 30 MHz:

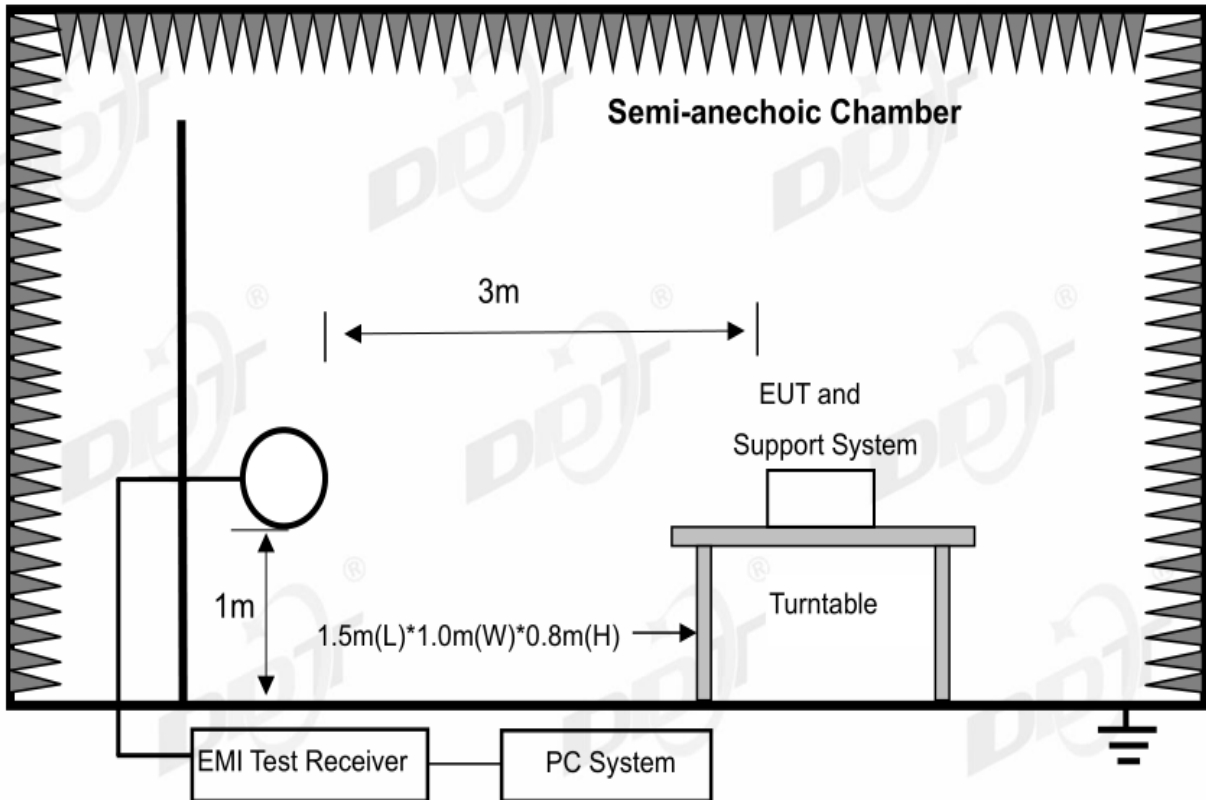

In 3 m Anechoic Chamber, test setup diagram for 30 MHz - 1 GHz:

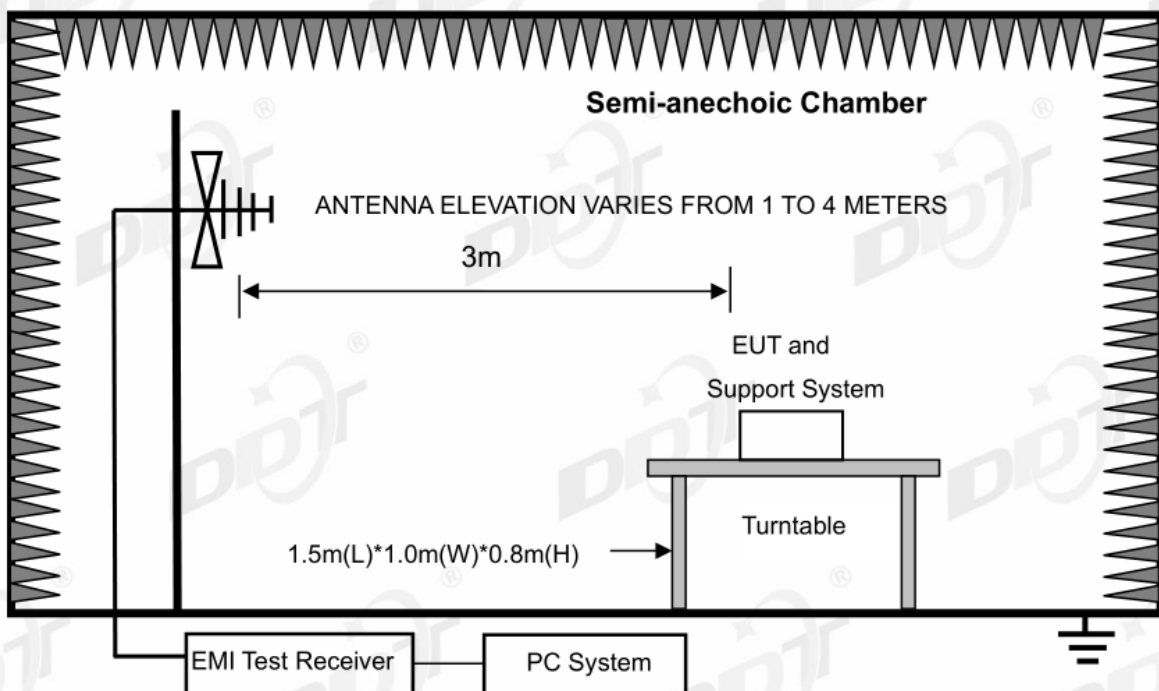

In 3 m Anechoic Chamber, test setup diagram for frequency above 1 GHz:

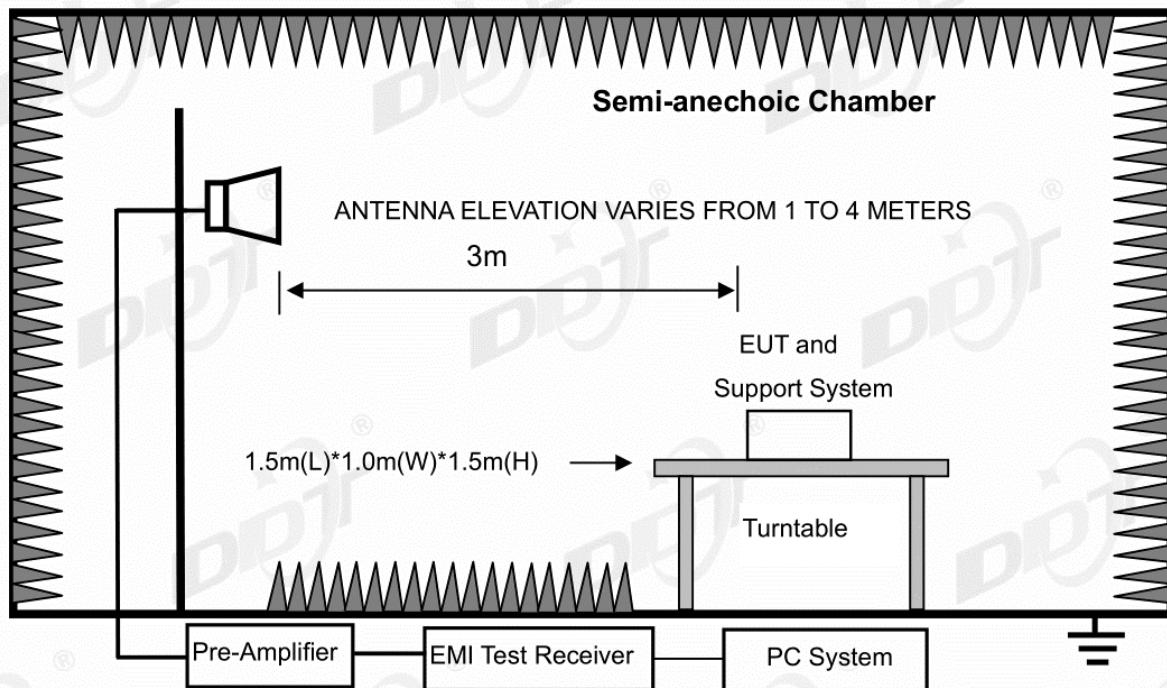

Note: For harmonic emissions test an appropriate high pass filter was inserted in the input port of AMP.

9.2. Limit

(1) FCC 15.205 Restricted frequency band

MHz	MHz	MHz	GHz
0.090-0.110	16.42-16.423	399.9-410	4.5-5.15
¹ 0.495-0.505	16.69475-16.69525	608-614	5.35-5.46
2.1735-2.1905	16.80425-16.80475	960-1240	7.25-7.75
4.125-4.128	25.5-25.67	1300-1427	8.025-8.5
4.1772&4.17775	37.5-38.25	1435-1626.5	9.0-9.2
4.2072&4.20775	73-74.6	1645.5-1646.5	9.3-9.5
6.215-6.218	74.8-75.2	1660-1710	10.6-12.7
6.26775-6.26825	108-121.94	1718.8-1722.2	13.25-13.4
6.31175-6.31225	123-138	2200-2300	14.47-14.5
8.291-8.294	149.9-150.05	2310-2390	15.35-16.2
8.362-8.366	156.52475-156.52525	2483.5-2500	17.7-21.4
8.37625-8.38675	156.7-156.9	2690-2900	22.01-23.12
8.41425-8.41475	162.0125-167.17	3260-3267	23.6-24.0
12.29-12.293	167.72-173.2	3332-3339	31.2-31.8
12.51975-12.52025	240-285	3345.8-3358	36.43-36.5
12.57675-12.57725	322-335.4	3600-4400	(²)
13.36-13.41			

¹Until February 1, 1999, this restricted band shall be 0.490-0.510 MHz.

²Above 38.6

RSS-Gen section 8.10 Restricted frequency bands*

MHz	MHz	MHz	GHz
0.090-0.110	12.51975-12.52025	240-285	3.5-4.4
0.495-0.505	12.57675-12.57725	322-335.4	4.5-5.15
2.1735-2.1905	13.36-13.41	399.9-410	5.35-5.46
3.020-3.026	16.42-16.423	608-614	7.25-7.75
4.125-4.128	16.69475-16.69525	960-1427	8.025-8.5
4.1772&4.17775	16.80425-16.80475	1435-1626.5	9.0-9.2
4.2072&4.20775	25.5-25.67	1645.5-1646.5	9.3-9.5
5.677-5.683	37.5-38.25	1660-1710	10.6-12.7
6.215-6.218	73-74.6	1718.8-1722.2	13.25-13.4
6.26775-6.26825	74.8-75.2	2200-2300	14.47-14.5
6.31175-6.31225	108-138	2310-2390	15.35-16.2
8.291-8.294	149.9-150.05	2483.5-2500	17.7-21.4
8.362-8.366	156.52475-156.52525	2655-2900	22.01-23.12
8.37625-8.38675	156.7-156.9	3260-3267	23.6-24.0
8.41425-8.41475	162.0125-167.17	3332-3339	31.2-31.8
12.29-12.293	167.72-173.2	3345.8-3358	36.43-36.5
			Above 38.6

* Certain frequency bands listed in table and in bands above 38.6 GHz are designated for licence-exempt applications. These frequency bands and the requirements that apply to related devices are set out in the 200 and 300 series of RSSs.

(2) FCC 15.209 Limit & RSS-Gen section 8.9 Limit

FREQUENCY (MHz)	DISTANCE Meters	FIELD STRENGTHS LIMIT	
		$\mu\text{V}/\text{m}$	$\text{dB}(\mu\text{V})/\text{m}$
0.009 ~ 0.490	300	2400/F(kHz)	67.6-20log(F)
0.490 ~ 1.705	30	24000/F(kHz)	87.6-20log(F)
1.705 ~ 30.0	30	30	29.54
30 ~ 88	3	100	40.0
88 ~ 216	3	150	43.5
216 ~ 960	3	200	46.0
960 ~ 1000	3	500	54.0
Above 1000	3	74.0 $\text{dB}(\mu\text{V})/\text{m}$ (Peak) 54.0 $\text{dB}(\mu\text{V})/\text{m}$ (Average)	

Note: (1) The emission limits shown in the above table are based on measurements employing a CISPR QP detector except for the frequency bands 9 - 90 kHz, 110 - 490 kHz and above 1000 MHz. Radiated emissions limits in these three bands are based on measurements employing an average detector.

(2) At frequencies below 30 MHz, measurement may be performed at a distance closer than that specified, and the limit at closer measurement distance can be extrapolated by below formula:

$$\text{Limit}_{3\text{m}}(\text{dB}\mu\text{V}/\text{m}) = \text{Limit}_{30\text{m}}(\text{dB}\mu\text{V}/\text{m}) + 40\text{Log}(30\text{m}/3\text{m})$$

(3) Limit for this EUT

The emissions appearing within 15.205 restricted frequency bands shall not exceed the limits shown in 15.209, and the emissions appearing within RSS-Gen section 8.10 Restricted frequency bands shall not exceed the limits shown in RSS-Gen section 8.9, all the other emissions shall be at least 20 dB below the fundamental emissions or comply with 15.209 limits and RSS-Gen section 8.9 limits.

9.3. Test Procedure

- (1) EUT was placed on a non-metallic table, 80 cm above the ground plane inside a semi-anechoic chamber for below 1 G and 150 cm above the ground plane inside a semi-anechoic chamber for above 1 G.
- (2) Test antenna was located 3 m from the EUT on an adjustable mast, and the antenna used as below table.

Test frequency range	Test antenna used	Test antenna distance
9 kHz - 30 MHz	Active Loop antenna	3 m
30 MHz - 1 GHz	Trilog Broadband Antenna	3 m
1 GHz - 18 GHz	Double Ridged Horn Antenna (1 GHz - 18 GHz)	3 m
18 GHz - 40 GHz	Horn Antenna (18 GHz - 40 GHz)	1 m

According ANSI C63.10:2013 clause 6.4.4.2 and 6.5.3, for measurements below 30 MHz, the loop antenna was positioned with its plane vertical from the EUT and rotated about its vertical axis for maximum response at each azimuth position around the EUT. And the loop antenna also is positioned with its plane horizontal at the specified distance from the EUT. The center of the loop is 1 m above the ground. For measurement above 30 MHz, the Trilog Broadband Antenna or Horn Antenna was located 3 m from EUT, Measurements were made with the antenna positioned in both the horizontal and vertical planes of Polarization, and the measurement antenna was varied from 1 m to 4 m. in height above the reference ground plane to obtain the maximum signal strength.

- (3) Below pre-scan procedure was first performed in order to find prominent frequency spectrum radiated emissions from 9 kHz to 25 GHz:
- (a) Scanning the peak frequency spectrum with the antenna specified in step (3), and the EUT was rotated 360 degree, the antenna height was varied from 1 m to 4 m (Except loop antenna, it's fixed 1 m above ground.)
 - (b) Change work frequency or channel of device if practicable.
 - (c) Change modulation type of device if practicable.
 - (d) Change power supply range from 85% to 115% of the rated supply voltage
 - (e) Rotated EUT though three orthogonal axes to determine the attitude of EUT arrangement produces highest emissions.

Spectrum frequency from 9 kHz to 25 GHz (tenth harmonic of fundamental frequency) was investigated, and no any obvious emission were detected from 9 kHz to 30 MHz and 18 GHz to 25 GHz, so below final test was performed with frequency range from 30 MHz to 18 GHz.

- (4) For final emissions measurements at each frequency of interest, the EUT was rotated and the antenna height was varied between 1 m and 4 m in order to maximize the emission. Measurements in both horizontal and vertical polarities were made and the data was recorded. In order to find the maximum emission, the relative positions of equipments and all of the interface cables were changed according to ANSI C63.10:2013 on Radiated Emission test.
- (5) The emissions from 9 kHz to 1 GHz were measured based on CISPR QP detector except for the frequency bands 9 - 90 kHz, 110 - 490 kHz, for emissions from 9 kHz - 90 kHz, 110 kHz - 490 kHz and above 1 GHz were measured based on average detector, for emissions above 1 GHz, peak emissions also be measured and need comply with Peak limit.
- (6) The emissions from 9 kHz to 1 GHz, QP or average values were measured with EMI receiver with below RBW

Frequency band	RBW
9 kHz - 150 kHz	200 Hz
150 kHz - 30 MHz	9 kHz
30 MHz - 1 GHz	120 kHz

- (7) For emissions above 1 GHz, both Peak and Average level were measured with Spectrum Analyzer, and the RBW is set at 1 MHz, VBW is set at 3 MHz for Peak measure; According ANSI C63.10:2013 clause 4.1.4.2.2 procedure for average measure.

9.4. Test result

Pass. (See below detailed test result)

All the emissions except fundamental emission from 9 kHz to 25 GHz were comply with 15.209 limits and RSS-Gen section 8.9 limits.

Note1: According exploratory test, the emission levels are 20 dB below the limit detected from 9 kHz to 30 MHz and 18 GHz to 25 GHz, so the final test was performed with frequency range from 30 MHz to 18 GHz and recorded in below.

Note2: For emissions below 1 GHz, according exploratory explorer test, when change Tx mode and channel, have no distinct influence on emissions level, so for emissions below 1 GHz, the final test was only performed with EUT working in the worst channel: 2402MHz.

Note3: For emissions above 1 GHz. If peak results comply with AV limit, AV Result is deemed to comply with AV limit.

Radiated Emission test (below 1 GHz)

TR-4-E-009 Radiated Emission Test Result

Test Date: 2023-05-19 **Tested By:** Bairong
EUT: LCD Smart Projector **Model:** XMM2101
Test Mode: TX Mode **Number:** XMM2101
Condition: Temp:23.5°C;Humi:66.7% **Power Supply:** AC 120V/60Hz
File Path: d:\ts\2023 report data\Q23042304-2E XMM2101\FCC BELOW 1G\20230519-023958_H
Memo: BLE 1M **Test Site:** DDT 3# Chamber

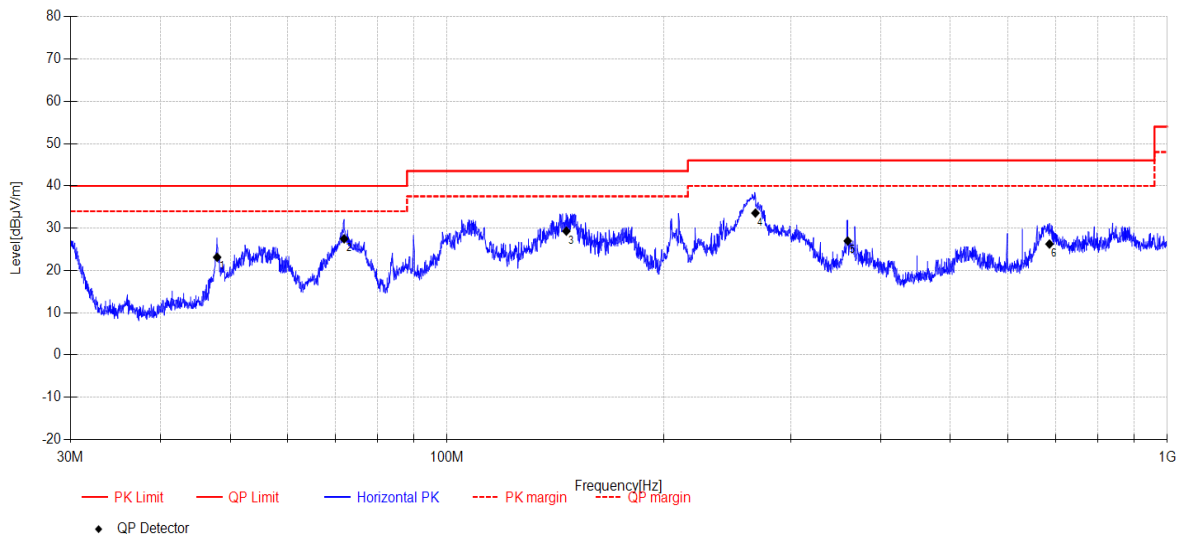

Final Data List										
NO.	Freq. [MHz]	Reading [dBµV/m]	Antenna Factor [dB]	Cable Loss [dB]	AMP [dB]	Result [dBµV/m]	Limit [dBµV/m]	Margin [dB]	Detector	Polarity
1	47.96	37.5	13.20	4.70	-32.28	23.12	40.00	16.88	QP	Horizontal
2	71.97	47.02	7.91	4.80	-32.26	27.47	40.00	12.53	QP	Horizontal
3	146.43	48.78	7.40	5.30	-32.18	29.30	43.50	14.20	QP	Horizontal
4	267.99	47.14	12.66	6.02	-32.25	33.57	46.00	12.43	QP	Horizontal
5	360.02	38.04	14.80	6.48	-32.34	26.98	46.00	19.02	QP	Horizontal
6	686.24	31.56	19.82	7.70	-32.84	26.24	46.00	19.76	QP	Horizontal

Note:

1. Result Level = Reading + Cable loss + Antenna Factor + AMP
2. If Peak Result complies with QP limit, QP Result is deemed to comply with QP limit.
3. Test setup: RBW: 120 kHz, VBW: 300 kHz, Sweep time: auto.

TR-4-E-009 Radiated Emission Test Result

Test Date: 2023-05-19 **Tested By:** Bairong
EUT: LCD Smart Projector **Model:** XMM2101
Test Mode: TX Mode **Number:**
Condition: Temp:23.5°C;Humi:66.7% **Power Supply:** AC 120V/60Hz
File Path: d:\ts\2023 report data\Q23042304-2E XMM2101\FCC BELOW 1G\20230519-024040_V
Memo: BLE 1M

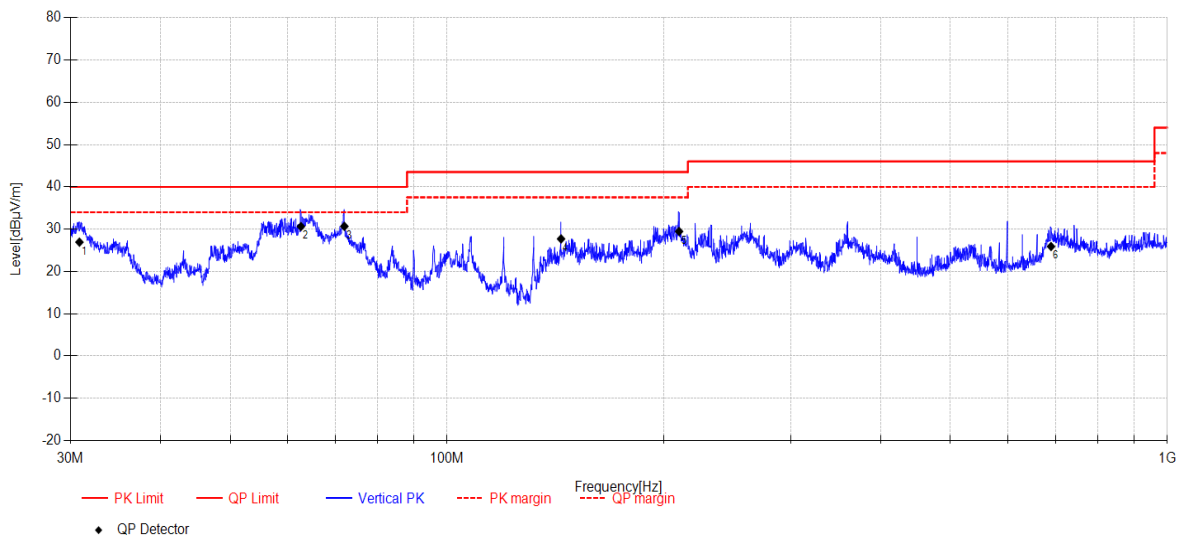

Final Data List										
NO.	Freq. [MHz]	Reading [dBµV/m]	Antenna Factor [dB]	Cable Loss [dB]	AMP [dB]	Result [dBµV/m]	Limit [dBµV/m]	Margin [dB]	Detector	Polarity
1	30.88	44.45	10.29	4.48	-32.29	26.93	40.00	13.07	QP	Vertical
2	62.69	46.94	11.19	4.77	-32.27	30.63	40.00	9.37	QP	Vertical
3	72.02	50.24	7.89	4.80	-32.26	30.67	40.00	9.33	QP	Vertical
4	143.99	47.2	7.40	5.29	-32.19	27.70	43.50	15.80	QP	Vertical
5	209.97	45.04	10.90	5.77	-32.24	29.47	43.50	14.03	QP	Vertical
6	689.62	31.14	19.89	7.72	-32.85	25.90	46.00	20.10	QP	Vertical

Note:

1. Result Level = Reading + Cable loss + Antenna Factor + AMP
2. If Peak Result complies with QP limit, QP Result is deemed to comply with QP limit.
3. Test setup: RBW: 120 kHz, VBW: 300 kHz, Sweep time: auto.

TR-4-E-009 Radiated Emission Test Result

Test Date: 2023-05-19 **Tested By:** Bairong
EUT: LCD Smart Projector **Model:** XMM2101
Test Mode: TX Mode **Number:** XMM2101
Condition: Temp:23.5°C;Humi:66.7% **Power Supply:** AC 120V/60Hz
File Path: d:\ts\2023 report data\Q23042304-2E XMM2101\FCC BELOW 1G\20230519-024133_H
Memo: BLE 2M **Test Site:** DDT 3# Chamber

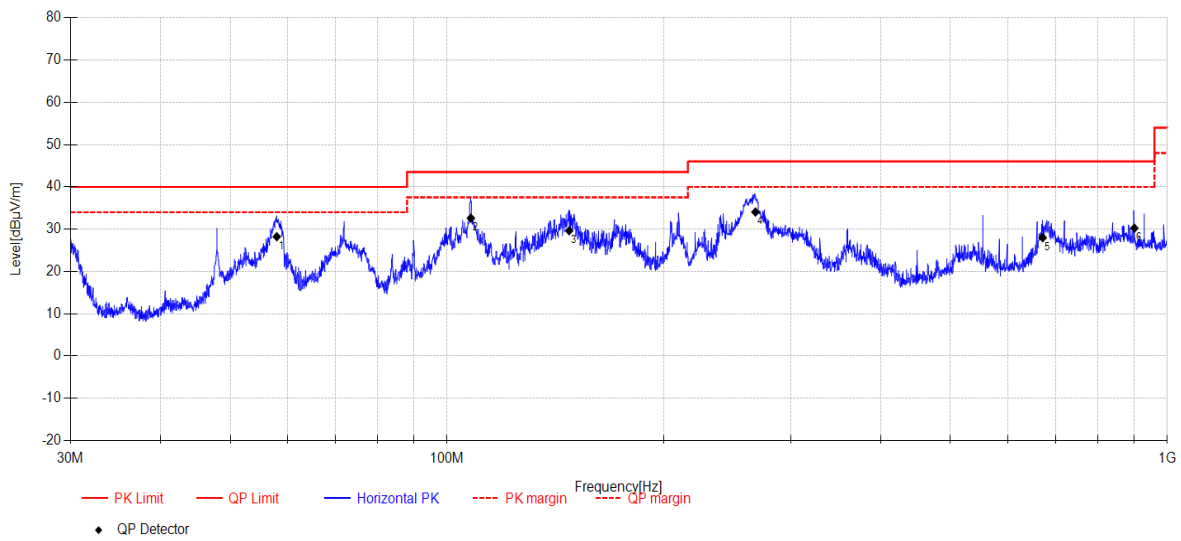

Final Data List										
NO.	Freq. [MHz]	Reading [dBµV/m]	Antenna Factor [dB]	Cable Loss [dB]	AMP [dB]	Result [dBµV/m]	Limit [dBµV/m]	Margin [dB]	Detector	Polarity
1	58.03	43.54	12.20	4.75	-32.27	28.22	40.00	11.78	QP	Horizontal
2	107.94	49	10.71	5.11	-32.23	32.59	43.50	10.91	QP	Horizontal
3	147.77	49.02	7.48	5.31	-32.18	29.63	43.50	13.87	QP	Horizontal
4	267.99	47.62	12.66	6.02	-32.25	34.05	46.00	11.95	QP	Horizontal
5	671.48	33.54	19.63	7.64	-32.82	27.99	46.00	18.01	QP	Horizontal
6	900.17	31.72	22.40	8.34	-32.23	30.23	46.00	15.77	QP	Horizontal

Note:

1. Result Level = Reading + Cable loss + Antenna Factor + AMP
2. If Peak Result complies with QP limit, QP Result is deemed to comply with QP limit.
3. Test setup: RBW: 120 kHz, VBW: 300 kHz, Sweep time: auto.

TR-4-E-009 Radiated Emission Test Result

Test Date: 2023-05-19 **Tested By:** Bairong
EUT: LCD Smart Projector **Model:** XMM2101
Test Mode: TX Mode **Number:**
Condition: Temp:23.5°C;Humi:66.7% **Power Supply:** AC 120V/60Hz
File Path: d:\ts\2023 report data\Q23042304-2E XMM2101\FCC BELOW 1G\20230519-024213_V
Memo: BLE 2M

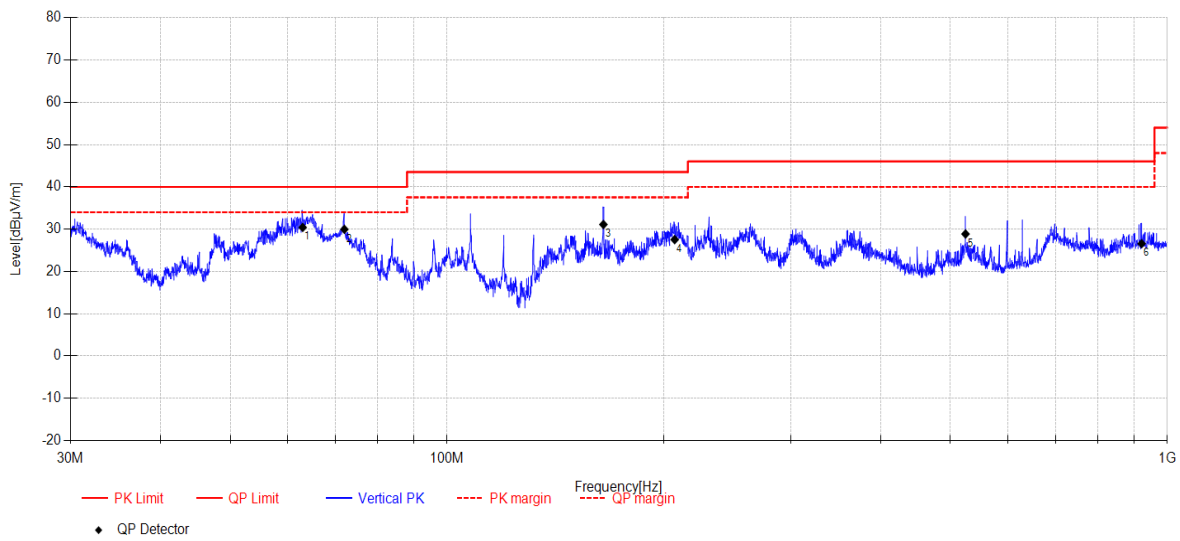

Final Data List										
NO.	Freq. [MHz]	Reading [dBµV/m]	Antenna Factor [dB]	Cable Loss [dB]	AMP [dB]	Result [dBµV/m]	Limit [dBµV/m]	Margin [dB]	Detector	Polarity
1	63.04	46.82	11.09	4.77	-32.27	30.41	40.00	9.59	QP	Vertical
2	72.02	49.52	7.89	4.80	-32.26	29.95	40.00	10.05	QP	Vertical
3	164.85	49.58	8.29	5.44	-32.21	31.10	43.50	12.40	QP	Vertical
4	207.04	43.17	10.84	5.76	-32.25	27.52	43.50	15.98	QP	Vertical
5	524.62	37.02	17.39	7.03	-32.58	28.86	46.00	17.14	QP	Vertical
6	921.24	27.63	22.50	8.41	-31.98	26.56	46.00	19.44	QP	Vertical

Note:

1. Result Level = Reading + Cable loss + Antenna Factor + AMP
2. If Peak Result complies with QP limit, QP Result is deemed to comply with QP limit.
3. Test setup: RBW: 120 kHz, VBW: 300 kHz, Sweep time: auto.

Radiated Emission test (above 1 GHz) TR-4-E-009 Radiated Emission Test Result

Test Date: 2023-05-10 **Tested By:** Bairong
EUT: LCD Smart Projector **Model Number:** XMM2101
Test Mode: TX Mode **Power Supply:** AC 120V/60Hz
Condition: Temp:23.5°C;Humi:66.7% **Test Site:** DDT 3# Chamber
File Path: d:\ts\2023 report data\Q23042304-2E XMM2101\FCC ABOVE 1G\7
Memo: BLE 1M 2402

Test Graph

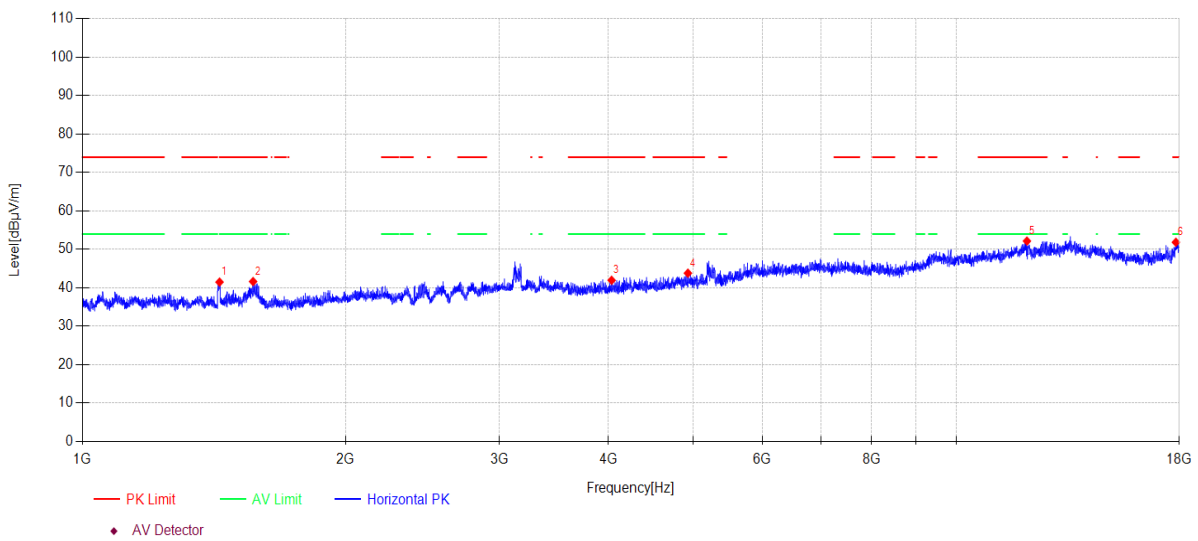

Suspected Data List										
NO	Freq. [MHz]	Reading [dBµV/m]	Cable loss [dB]	Antenna Factor [dB]	AMP [dB]	Level [dBµV /m]	Limit [dBµV /m]	Margin [dB]	Detector	Polarity
1	1435.14	51.29	3.46	25.60	-38.85	41.50	74.00	32.50	PK	Horizontal
2	1567.84	51.61	3.68	25.40	-39.05	41.64	74.00	32.36	PK	Horizontal
3	4032.82	46.85	5.74	30.77	-41.39	41.97	74.00	32.03	PK	Horizontal
4	4931.36	46.17	6.03	32.73	-41.12	43.81	74.00	30.19	PK	Horizontal
5	12048.49	43.69	8.43	39.00	-38.95	52.17	74.00	21.83	PK	Horizontal
6	17839.45	39.94	11.78	40.78	-40.64	51.86	74.00	22.14	PK	Horizontal

Note:

1. Level = Reading + Cable loss + Antenna Factor + AMP
2. If Peak Result complies with AV limit, AV Result is deemed to comply with AV limit.
3. Test setup: RBW: 1 MHz, VBW: 3 MHz, Sweep time: auto.

TR-4-E-009 Radiated Emission Test Result

Test Date: 2023-05-10 **Tested By:** Bairong
EUT: LCD Smart Projector **Model Number:** XMM2101
Test Mode: TX Mode **Power Supply:** AC 120V/60Hz
Condition: Temp:23.5°C;Humi:66.7% **Test Site:** DDT 3# Chamber
File Path: d:\ts\2023 report data\Q23042304-2E XMM2101\FCC ABOVE 1G\8
Memo: BLE 1M 2402

Test Graph

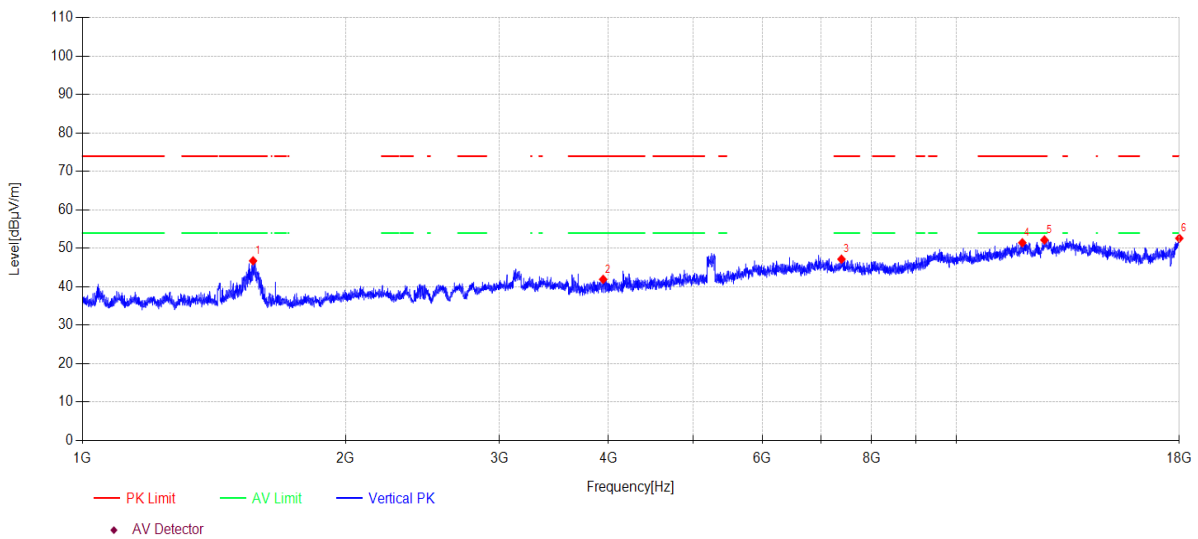

Suspected Data List										
NO	Freq. [MHz]	Reading [dBµV/m]	Cable loss [dB]	Antenna Factor [dB]	AMP [dB]	Level [dBµV/m]	Limit [dBµV/m]	Margin [dB]	Detector	Polarity
1	1567.84	56.74	3.68	25.40	-39.05	46.77	74.00	27.23	PK	Vertical
2	3944.06	47.03	5.70	30.59	-41.37	41.95	74.00	32.05	PK	Vertical
3	7390.73	44.52	7.17	36.50	-41.00	47.19	74.00	26.81	PK	Vertical
4	11903.12	43.38	8.35	38.80	-39.06	51.47	74.00	22.53	PK	Vertical
5	12618.71	43.51	8.96	39.24	-39.52	52.19	74.00	21.81	PK	Vertical
6	18000.00	39.52	12.00	41.80	-40.70	52.62	74.00	21.38	PK	Vertical

Note:

1. Level = Reading + Cable loss + Antenna Factor + AMP
2. If Peak Result complies with AV limit, AV Result is deemed to comply with AV limit.
3. Test setup: RBW: 1 MHz, VBW: 3 MHz, Sweep time: auto.

TR-4-E-009 Radiated Emission Test Result

Test Date: 2023-05-10 **Tested By:** Bairong
EUT: LCD Smart Projector **Model Number:** XMM2101
Test Mode: TX Mode **Power Supply:** AC 120V/60Hz
Condition: Temp:23.5°C;Humi:66.7% **Test Site:** DDT 3# Chamber
File Path: d:\ts\2023 report data\Q23042304-2E XMM2101\FCC ABOVE 1G\9
Memo: BLE 1M 2440

Test Graph

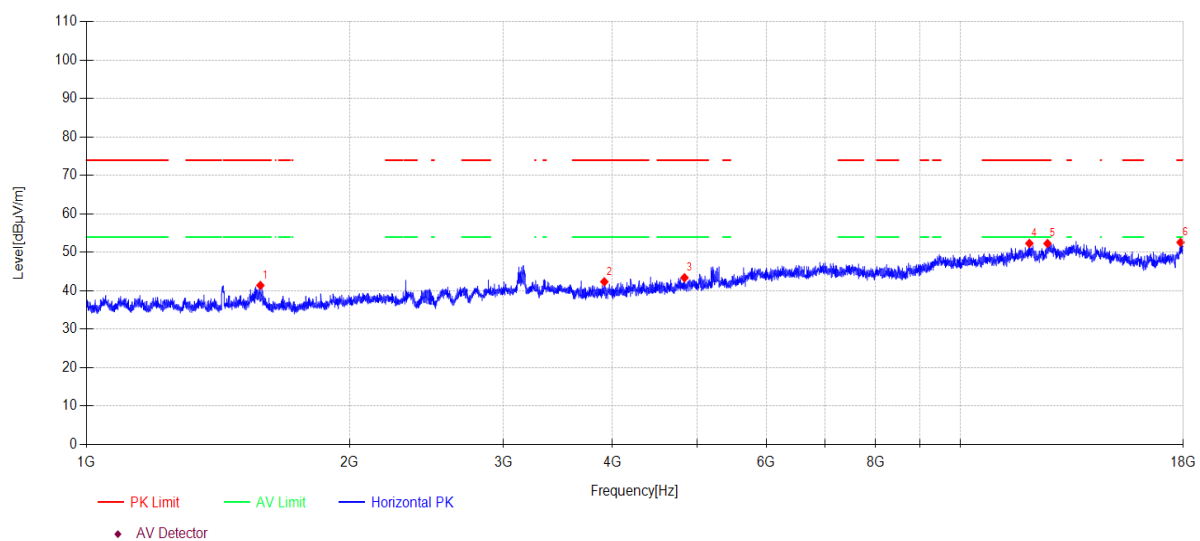

Suspected Data List										
NO	Freq. [MHz]	Reading [dBμV/m]	Cable loss [dB]	Antenna Factor [dB]	AMP [dB]	Level [dBμV/m]	Limit [dBμV/m]	Margin [dB]	Detector	Polarity
1	1581.49	51.38	3.70	25.40	-39.07	41.41	74.00	32.59	PK	Horizontal
2	3914.54	47.50	5.68	30.53	-41.35	42.36	74.00	31.64	PK	Horizontal
3	4835.39	46.11	6.00	32.44	-41.15	43.40	74.00	30.60	PK	Horizontal
4	11999.84	43.96	8.38	38.90	-38.90	52.34	74.00	21.66	PK	Horizontal
5	12585.93	43.68	8.93	39.19	-39.49	52.31	74.00	21.69	PK	Horizontal
6	17870.42	40.43	11.83	40.99	-40.65	52.60	74.00	21.40	PK	Horizontal

Note:

- Level = Reading + Cable loss + Antenna Factor + AMP
- If Peak Result complies with AV limit, AV Result is deemed to comply with AV limit.
- Test setup: RBW: 1 MHz, VBW: 3 MHz, Sweep time: auto.

TR-4-E-009 Radiated Emission Test Result

Test Date: 2023-05-10 **Tested By:** Bairong
EUT: LCD Smart Projector **Model Number:** XMM2101
Test Mode: TX Mode **Power Supply:** AC 120V/60Hz
Condition: Temp:23.5°C;Humi:66.7% **Test Site:** DDT 3# Chamber
File Path: d:\ts\2023 report data\Q23042304-2E XMM2101\FCC ABOVE 1G\10
Memo: BLE 1M 2440

Test Graph

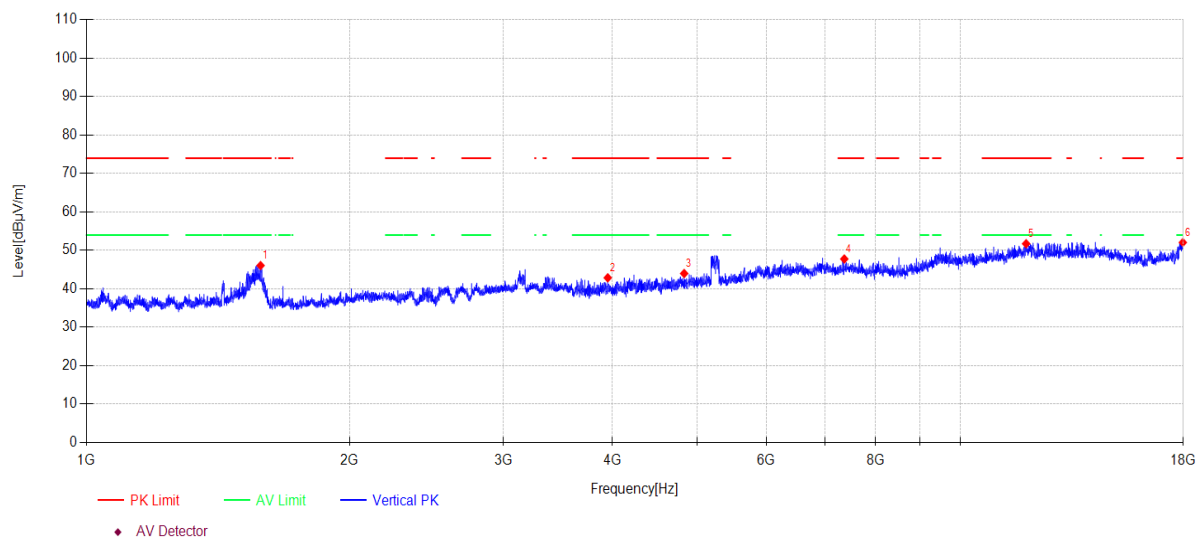

Suspected Data List										
NO	Freq. [MHz]	Reading [dBμV/m]	Cable loss [dB]	Antenna Factor [dB]	AMP [dB]	Level [dBμV/m]	Limit [dBμV/m]	Margin [dB]	Detector	Polarity
1	1582.40	56.02	3.71	25.40	-39.07	46.06	74.00	27.94	PK	Vertical
2	3949.77	47.94	5.70	30.60	-41.37	42.87	74.00	31.13	PK	Vertical
3	4831.20	46.72	6.00	32.42	-41.15	43.99	74.00	30.01	PK	Vertical
4	7367.27	45.08	7.18	36.50	-41.00	47.76	74.00	26.24	PK	Vertical
5	11896.25	43.66	8.34	38.80	-39.07	51.73	74.00	22.27	PK	Vertical
6	17979.20	39.09	11.97	41.68	-40.69	52.05	74.00	21.95	PK	Vertical

Note:

1. Level = Reading + Cable loss + Antenna Factor + AMP
2. If Peak Result complies with AV limit, AV Result is deemed to comply with AV limit.
3. Test setup: RBW: 1 MHz, VBW: 3 MHz, Sweep time: auto.

TR-4-E-009 Radiated Emission Test Result

Test Date: 2023-05-10 **Tested By:** Bairong
EUT: LCD Smart Projector **Model Number:** XMM2101
Test Mode: TX Mode **Power Supply:** AC 120V/60Hz
Condition: Temp:23.5°C;Humi:66.7% **Test Site:** DDT 3# Chamber
File Path: d:\ts\2023 report data\Q23042304-2E XMM2101\FCC ABOVE 1G\11
Memo: BLE 1M 2480

Test Graph

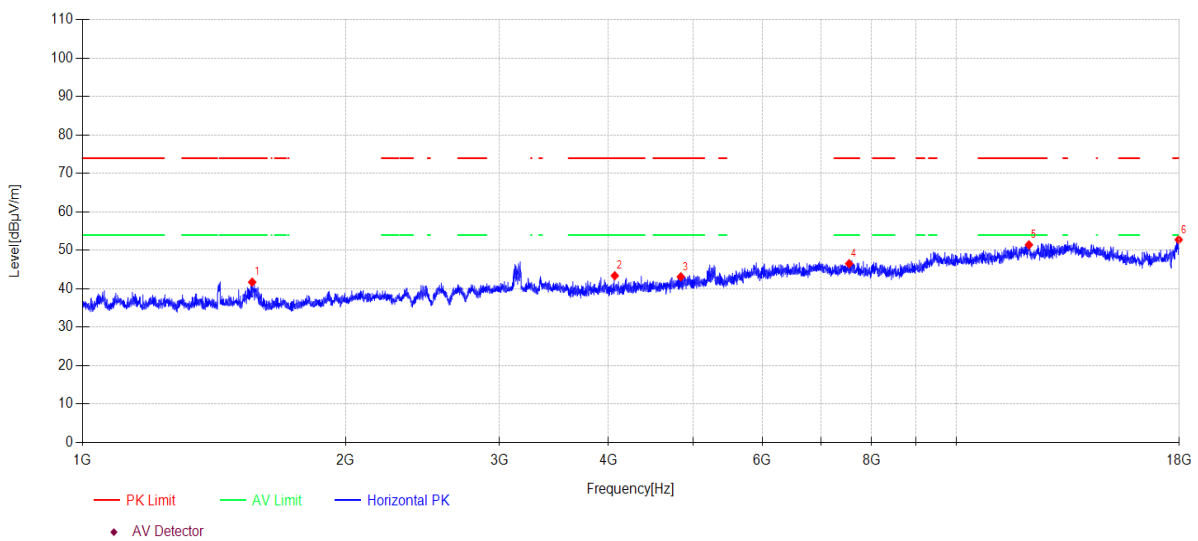

Suspected Data List										
NO	Freq. [MHz]	Reading [dBµV/m]	Cable loss [dB]	Antenna Factor [dB]	AMP [dB]	Level [dBµV/m]	Limit [dBµV/m]	Margin [dB]	Detector	Polarity
1	1564.22	51.71	3.68	25.40	-39.05	41.74	74.00	32.26	PK	Horizontal
2	4066.76	48.21	5.75	30.83	-41.38	43.41	74.00	30.59	PK	Horizontal
3	4839.59	45.82	6.00	32.46	-41.15	43.13	74.00	30.87	PK	Horizontal
4	7541.77	44.01	7.14	36.40	-41.00	46.55	74.00	27.45	PK	Horizontal
5	12111.33	42.87	8.48	39.10	-39.01	51.44	74.00	22.56	PK	Horizontal
6	17974.01	39.86	11.96	41.64	-40.69	52.77	74.00	21.23	PK	Horizontal

Note:

1. Level = Reading + Cable loss + Antenna Factor + AMP
2. If Peak Result complies with AV limit, AV Result is deemed to comply with AV limit.
3. Test setup: RBW: 1 MHz, VBW: 3 MHz, Sweep time: auto.

TR-4-E-009 Radiated Emission Test Result

Test Date: 2023-05-10 **Tested By:** Bairong
EUT: LCD Smart Projector **Model Number:** XMM2101
Test Mode: TX Mode **Power Supply:** AC 120V/60Hz
Condition: Temp:23.5°C;Humi:66.7% **Test Site:** DDT 3# Chamber
File Path: d:\ts\2023 report data\Q23042304-2E XMM2101\FCC ABOVE 1G\12
Memo: BLE 1M 2480

Test Graph

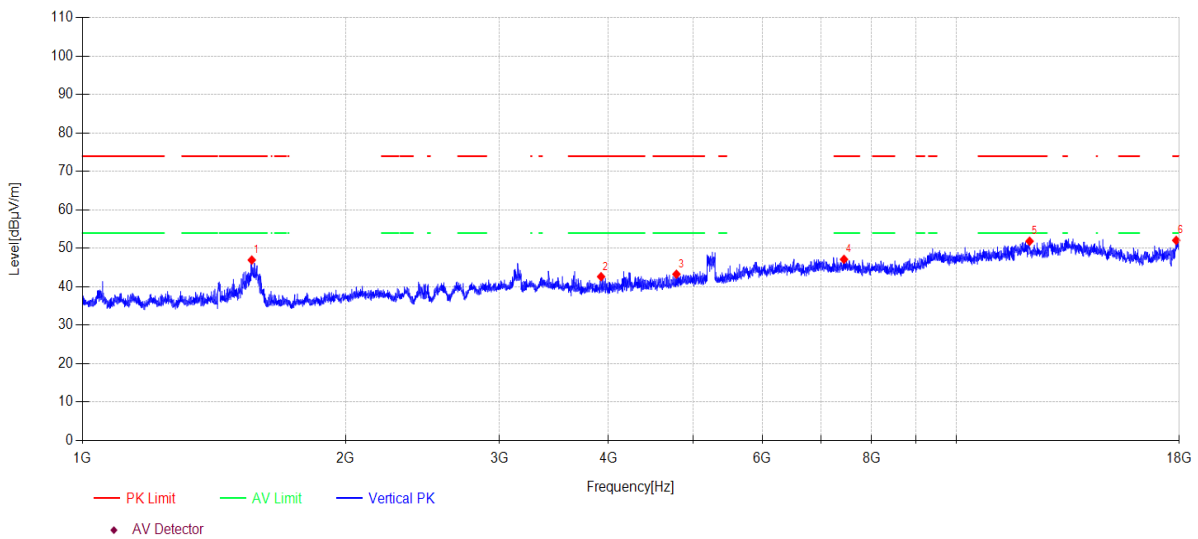

Suspected Data List										
NO	Freq. [MHz]	Reading [dBµV/m]	Cable loss [dB]	Antenna Factor [dB]	AMP [dB]	Level [dBµV/m]	Limit [dBµV/m]	Margin [dB]	Detector	Polarity
1	1562.41	56.94	3.67	25.40	-39.04	46.97	74.00	27.03	PK	Vertical
2	3922.46	47.76	5.69	30.54	-41.35	42.64	74.00	31.36	PK	Vertical
3	4783.96	46.23	5.98	32.24	-41.16	43.29	74.00	30.71	PK	Vertical
4	7440.02	44.49	7.16	36.50	-41.00	47.15	74.00	26.85	PK	Vertical
5	12132.35	43.30	8.50	39.10	-39.03	51.87	74.00	22.13	PK	Vertical
6	17854.93	40.04	11.80	40.88	-40.64	52.08	74.00	21.92	PK	Vertical

Note:

1. Level = Reading + Cable loss + Antenna Factor + AMP
2. If Peak Result complies with AV limit, AV Result is deemed to comply with AV limit.
3. Test setup: RBW: 1 MHz, VBW: 3 MHz, Sweep time: auto.

TR-4-E-009 Radiated Emission Test Result

Test Date: 2023-05-10 **Tested By:** Bairong
EUT: LCD Smart Projector **Model Number:** XMM2101
Test Mode: TX Mode **Power Supply:** AC 120V/60Hz
Condition: Temp:23.5°C;Humi:66.7% **Test Site:** DDT 3# Chamber
File Path: d:\ts\2023 report data\Q23042304-2E XMM2101\FCC ABOVE 1G\13
Memo: BLE 2M 2402

Test Graph

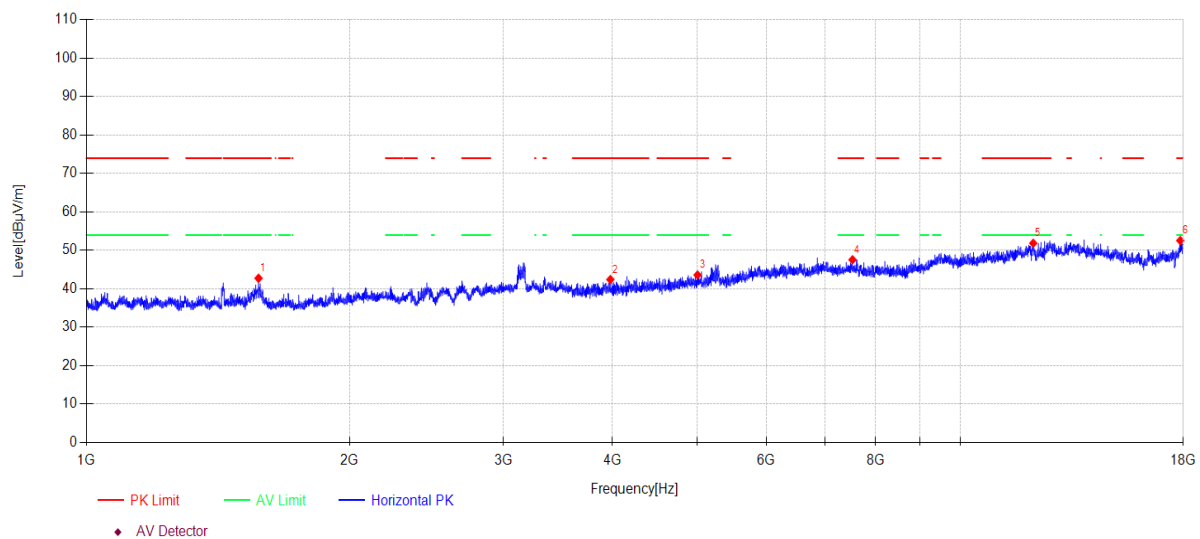

Suspected Data List										
NO	Freq. [MHz]	Reading [dBµV/m]	Cable loss [dB]	Antenna Factor [dB]	AMP [dB]	Level [dBµV/m]	Limit [dBµV/m]	Margin [dB]	Detector	Polarity
1	1573.74	52.72	3.69	25.40	-39.06	42.75	74.00	31.25	PK	Horizontal
2	3977.26	47.44	5.72	30.65	-41.39	42.42	74.00	31.58	PK	Horizontal
3	5004.58	45.84	6.06	32.81	-41.10	43.61	74.00	30.39	PK	Horizontal
4	7528.70	45.02	7.14	36.40	-41.00	47.56	74.00	26.44	PK	Horizontal
5	12121.84	43.30	8.49	39.10	-39.02	51.87	74.00	22.13	PK	Horizontal
6	17860.09	40.46	11.81	40.92	-40.64	52.55	74.00	21.45	PK	Horizontal

Note:

- Level = Reading + Cable loss + Antenna Factor + AMP
- If Peak Result complies with AV limit, AV Result is deemed to comply with AV limit.
- Test setup: RBW: 1 MHz, VBW: 3 MHz, Sweep time: auto.

TR-4-E-009 Radiated Emission Test Result

Test Date: 2023-05-10 **Tested By:** Bairong
EUT: LCD Smart Projector **Model Number:** XMM2101
Test Mode: TX Mode **Power Supply:** AC 120V/60Hz
Condition: Temp:23.5°C;Humi:66.7% **Test Site:** DDT 3# Chamber
File Path: d:\ts\2023 report data\Q23042304-2E XMM2101\FCC ABOVE 1G\14
Memo: BLE 2M 2402

Test Graph

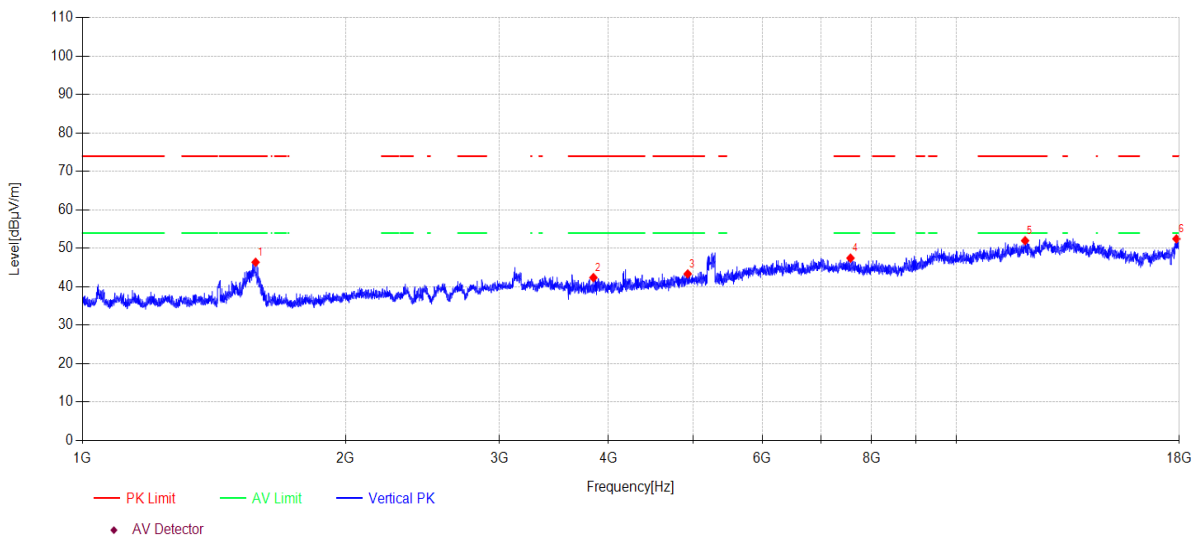

Suspected Data List										
NO	Freq. [MHz]	Reading [dBµV/m]	Cable loss [dB]	Antenna Factor [dB]	AMP [dB]	Level [dBµV/m]	Limit [dBµV/m]	Margin [dB]	Detector	Polarity
1	1578.29	56.36	3.70	25.40	-39.07	46.39	74.00	27.61	PK	Vertical
2	3843.91	47.67	5.65	30.39	-41.31	42.40	74.00	31.60	PK	Vertical
3	4928.51	45.74	6.03	32.71	-41.12	43.36	74.00	30.64	PK	Vertical
4	7567.97	44.93	7.14	36.40	-41.00	47.47	74.00	26.53	PK	Vertical
5	11989.44	43.65	8.38	38.89	-38.92	52.00	74.00	22.00	PK	Vertical
6	17865.25	40.35	11.82	40.96	-40.65	52.48	74.00	21.52	PK	Vertical

Note:

1. Level = Reading + Cable loss + Antenna Factor + AMP
2. If Peak Result complies with AV limit, AV Result is deemed to comply with AV limit.
3. Test setup: RBW: 1 MHz, VBW: 3 MHz, Sweep time: auto.

TR-4-E-009 Radiated Emission Test Result

Test Date: 2023-05-10 **Tested By:** Bairong
EUT: LCD Smart Projector **Model Number:** XMM2101
Test Mode: TX Mode **Power Supply:** AC 120V/60Hz
Condition: Temp:23.5°C;Humi:66.7% **Test Site:** DDT 3# Chamber
File Path: d:\ts\2023 report data\Q23042304-2E XMM2101\FCC ABOVE 1G\15
Memo: BLE 2M 2440

Test Graph

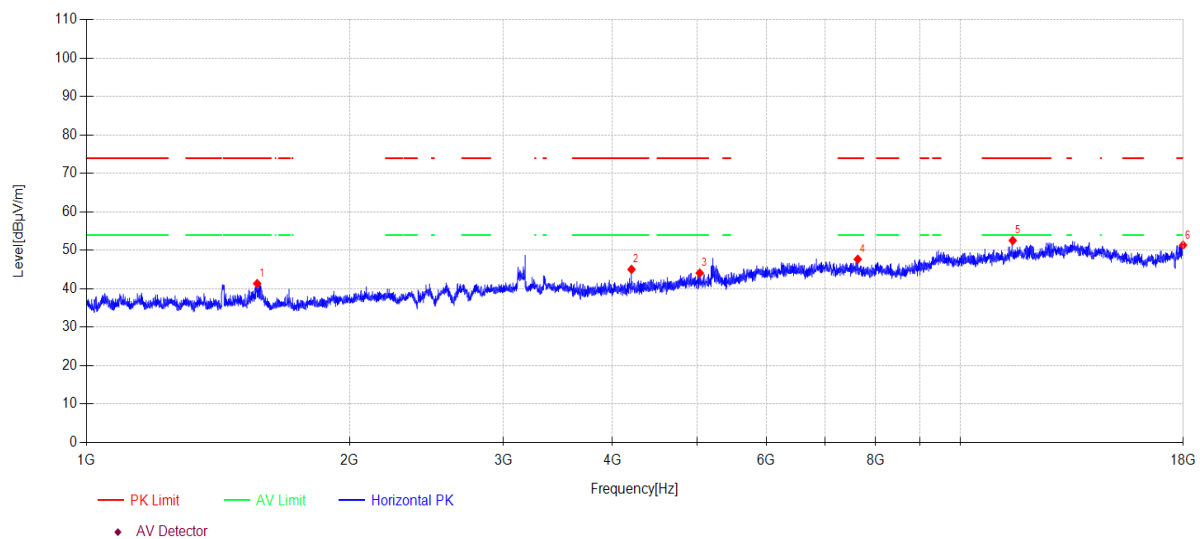

Suspected Data List										
NO	Freq. [MHz]	Reading [dBμV/m]	Cable loss [dB]	Antenna Factor [dB]	AMP [dB]	Level [dBμV/m]	Limit [dBμV/m]	Margin [dB]	Detector	Polarity
1	1568.29	51.34	3.68	25.40	-39.05	41.37	74.00	32.63	PK	Horizontal
2	4205.41	49.49	5.80	31.11	-41.34	45.06	74.00	28.94	PK	Horizontal
3	5033.59	46.21	6.12	32.87	-41.09	44.11	74.00	29.89	PK	Horizontal
4	7633.87	45.10	7.12	36.47	-41.00	47.69	74.00	26.31	PK	Horizontal
5	11484.10	45.08	8.19	39.02	-39.73	52.56	74.00	21.44	PK	Horizontal
6	17989.60	38.33	11.99	41.74	-40.70	51.36	74.00	22.64	PK	Horizontal

Note:

1. Level = Reading + Cable loss + Antenna Factor + AMP
2. If Peak Result complies with AV limit, AV Result is deemed to comply with AV limit.
3. Test setup: RBW: 1 MHz, VBW: 3 MHz, Sweep time: auto.

TR-4-E-009 Radiated Emission Test Result

Test Date: 2023-05-10 **Tested By:** Bairong
EUT: LCD Smart Projector **Model Number:** XMM2101
Test Mode: TX Mode **Power Supply:** AC 120V/60Hz
Condition: Temp:23.5°C;Humi:66.7% **Test Site:** DDT 3# Chamber
File Path: d:\ts\2023 report data\Q23042304-2E XMM2101\FCC ABOVE 1G\16
Memo: BLE 2M 2440

Test Graph

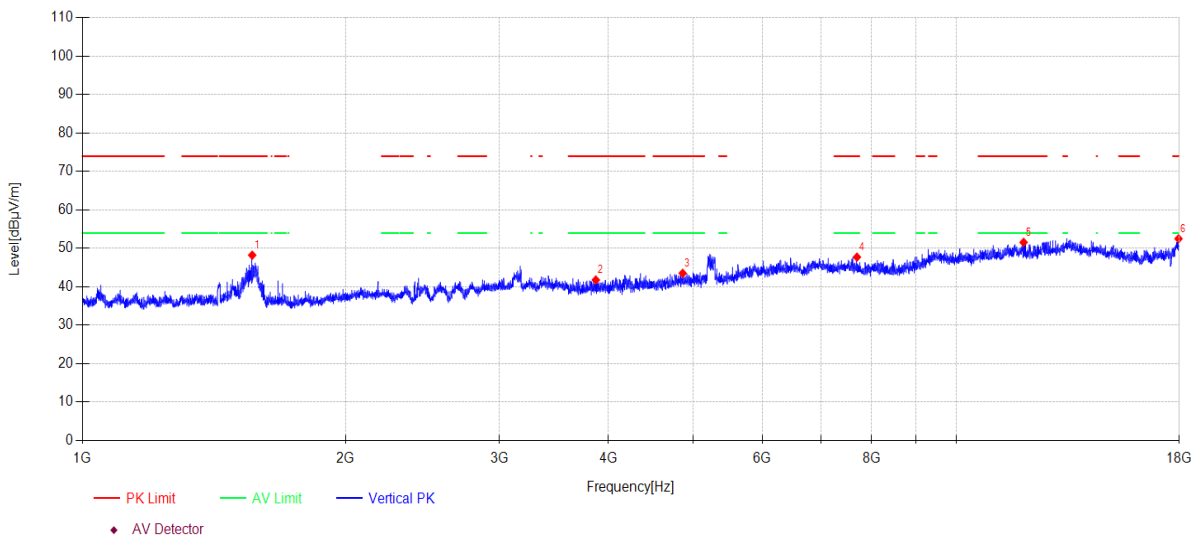

Suspected Data List										
NO	Freq. [MHz]	Reading [dBµV/m]	Cable loss [dB]	Antenna Factor [dB]	AMP [dB]	Level [dBµV/m]	Limit [dBµV/m]	Margin [dB]	Detector	Polarity
1	1564.22	58.20	3.68	25.40	-39.05	48.23	74.00	25.77	PK	Vertical
2	3868.43	47.01	5.66	30.44	-41.32	41.79	74.00	32.21	PK	Vertical
3	4863.42	46.12	6.01	32.53	-41.14	43.52	74.00	30.48	PK	Vertical
4	7698.12	45.03	7.11	36.60	-41.00	47.74	74.00	26.26	PK	Vertical
5	11944.48	43.36	8.36	38.84	-38.99	51.57	74.00	22.43	PK	Vertical
6	17963.62	39.67	11.95	41.58	-40.69	52.51	74.00	21.49	PK	Vertical

Note:

1. Level = Reading + Cable loss + Antenna Factor + AMP
2. If Peak Result complies with AV limit, AV Result is deemed to comply with AV limit.
3. Test setup: RBW: 1 MHz, VBW: 3 MHz, Sweep time: auto.

TR-4-E-009 Radiated Emission Test Result

Test Date: 2023-05-10 **Tested By:** Bairong
EUT: LCD Smart Projector **Model Number:** XMM2101
Test Mode: TX Mode **Power Supply:** AC 120V/60Hz
Condition: Temp:23.5°C;Humi:66.7% **Test Site:** DDT 3# Chamber
File Path: d:\ts\2023 report data\Q23042304-2E XMM2101\FCC ABOVE 1G\17
Memo: BLE 2M 2480

Test Graph

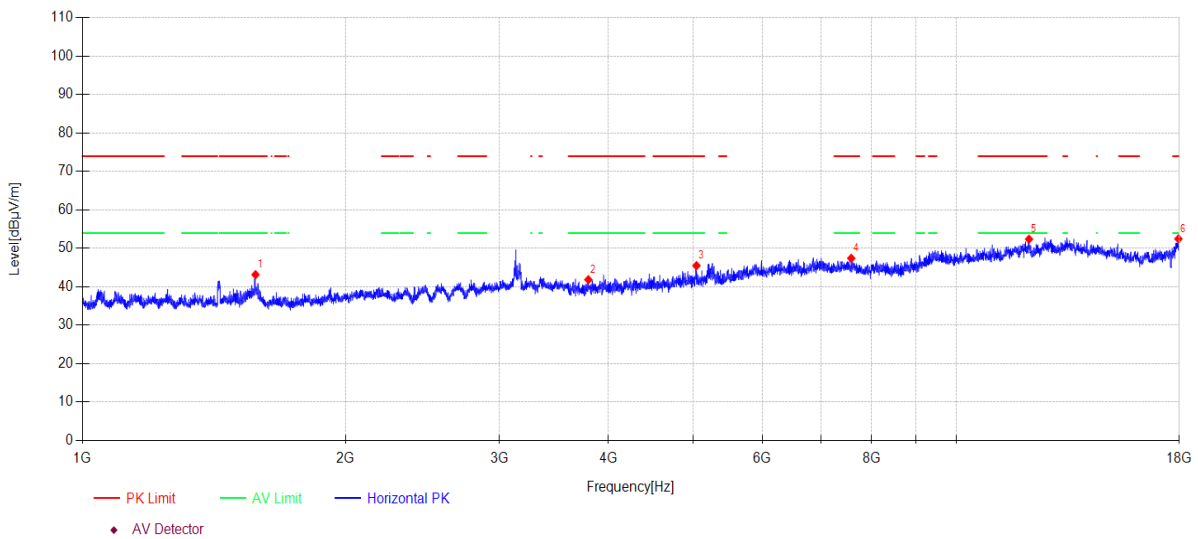

Suspected Data List										
NO	Freq. [MHz]	Reading [dBµV/m]	Cable loss [dB]	Antenna Factor [dB]	AMP [dB]	Level [dBµV/m]	Limit [dBµV/m]	Margin [dB]	Detector	Polarity
1	1577.84	53.13	3.70	25.40	-39.07	43.16	74.00	30.84	PK	Horizontal
2	3793.14	47.25	5.62	30.27	-41.28	41.86	74.00	32.14	PK	Horizontal
3	5043.79	47.56	6.14	32.89	-41.08	45.51	74.00	28.49	PK	Horizontal
4	7583.30	44.89	7.13	36.40	-41.00	47.42	74.00	26.58	PK	Horizontal
5	12114.83	43.81	8.49	39.10	-39.01	52.39	74.00	21.61	PK	Horizontal
6	17958.43	39.66	11.94	41.55	-40.68	52.47	74.00	21.53	PK	Horizontal

Note:

1. Level = Reading + Cable loss + Antenna Factor + AMP
2. If Peak Result complies with AV limit, AV Result is deemed to comply with AV limit.
3. Test setup: RBW: 1 MHz, VBW: 3 MHz, Sweep time: auto.

TR-4-E-009 Radiated Emission Test Result

Test Date: 2023-05-10 **Tested By:** Bairong
EUT: LCD Smart Projector **Model Number:** XMM2101
Test Mode: TX Mode **Power Supply:** AC 120V/60Hz
Condition: Temp:23.5°C;Humi:66.7% **Test Site:** DDT 3# Chamber
File Path: d:\ts\2023 report data\Q23042304-2E XMM2101\FCC ABOVE 1G\18
Memo: BLE 2M 2480

Test Graph

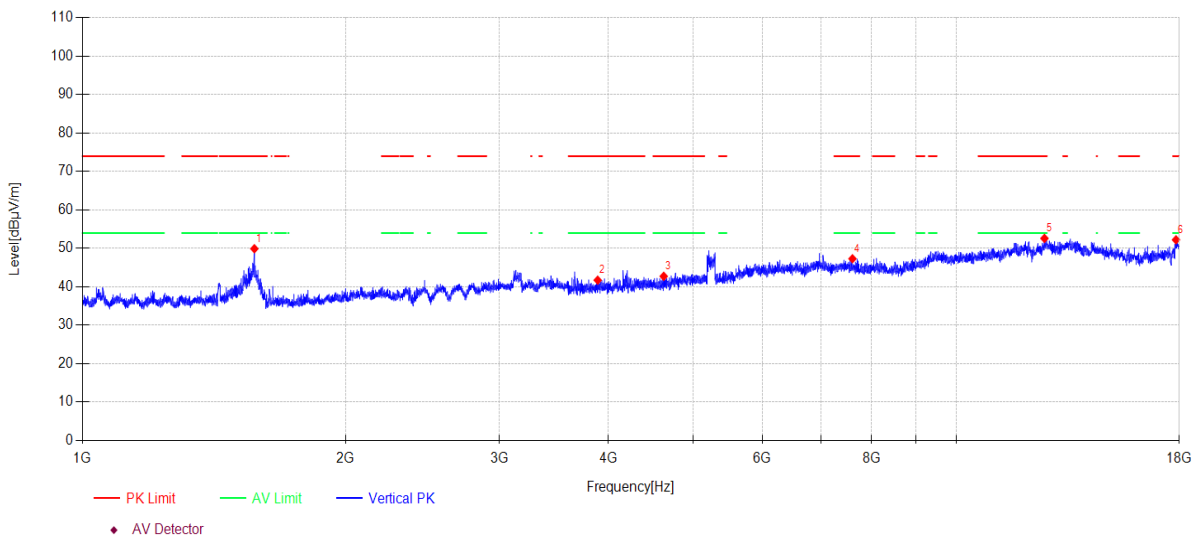

Suspected Data List										
NO	Freq. [MHz]	Reading [dBµV/m]	Cable loss [dB]	Antenna Factor [dB]	AMP [dB]	Level [dBµV/m]	Limit [dBµV/m]	Margin [dB]	Detector	Polarity
1	1573.28	59.88	3.69	25.40	-39.06	49.91	74.00	24.09	PK	Vertical
2	3887.48	46.92	5.67	30.47	-41.33	41.73	74.00	32.27	PK	Vertical
3	4626.24	46.27	5.93	31.75	-41.21	42.74	74.00	31.26	PK	Vertical
4	7607.44	44.77	7.13	36.41	-41.00	47.31	74.00	26.69	PK	Vertical
5	12618.71	43.92	8.96	39.24	-39.52	52.60	74.00	21.40	PK	Vertical
6	17844.61	40.27	11.79	40.81	-40.64	52.23	74.00	21.77	PK	Vertical

Note:

1. Level = Reading + Cable loss + Antenna Factor + AMP
2. If Peak Result complies with AV limit, AV Result is deemed to comply with AV limit.
3. Test setup: RBW: 1 MHz, VBW: 3 MHz, Sweep time: auto.