

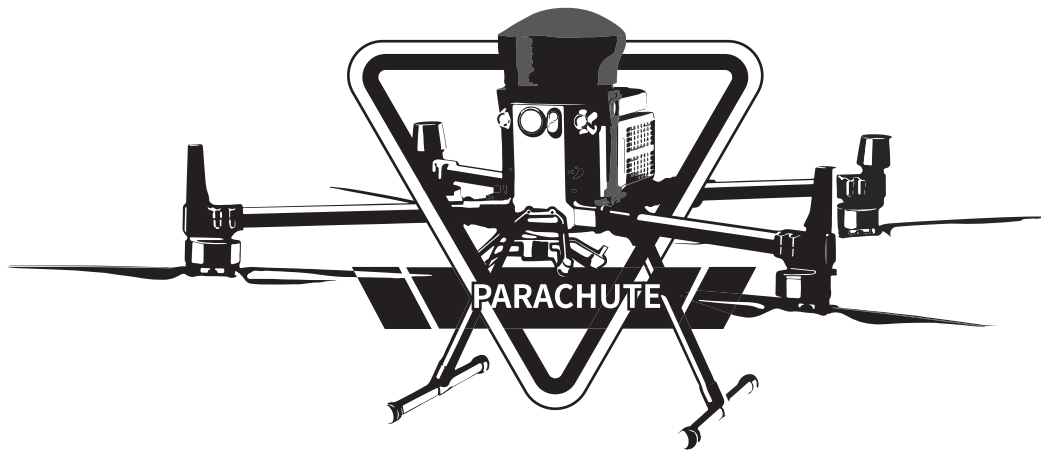

DRONE SAFETY SYSTEM
MATRICE 300 RTK



Flyfire.

WWW.IDOFUTURE.COM



FOREWORD

Thank you very much for choosing (OWL), the parachute of Flyfire applicable to M300 UAV (DJI Model:M300,FCC ID:SS3-M3001910 IC:11805A-M3001910 , DJI M300 Remote control Model:RM500-ENT, FCC ID:SS3-RM500E1910,IC:11805A-RM500E1910) To facilitate your use , we provide an instruction manual for you Please read this instruction manual carefully before use and keep it properly for reference. We reserve the rights to revise, alter or translate the user 's manual without prior notice. Therefore, we suggest that you visit our website at any time to understand the latest information.



SCAN THE CODE TO ENTER THE OFFICIAL WEBSITE

PLEASE READ THIS INSTRUCTION MANUAL CAREFULLY BEFORE USING THE PRODUCT AND KEEP IT PROPERLY

This device complies with Part 15 of the FCC Rules. Operation is subject to the following two conditions: (1) this device may not cause harmful interference, and (2) this device must accept any interference received, including interference that may cause undesired operation.

Changes or modifications to this unit not expressly approved by the party responsible for compliance could void the user's authority to operate the equipment.

NOTE: This equipment has been tested and found to comply with the limits for a Class B digital device, pursuant to Part 15 of the FCC Rules. These limits are designed to provide reasonable protection against harmful interference in a residential installation. This equipment generates uses and can radiate radio frequency energy and, if not installed and used in accordance with the instructions, may cause harmful interference to radio communications.

However, there is no guarantee that interference will not occur in a particular installation. If this equipment does cause harmful interference to radio or television reception, which can be determined by turning the equipment off and on, the user is encouraged to try to correct the interference by one or more of the following measures:

- Reorient or relocate the receiving antenna.*
- Increase the separation between the equipment and receiver.*
- Connect the equipment into an outlet on a circuit different from that to which the receiver is connected.*
- Consult the dealer or an experienced radio/TV technician for help.*

Remarks: The following applies to safe parachute

This equipment complies with FCC radiation exposure limits set forth for an uncontrolled environment. This equipment should be installed and operated with a minimum distance of 20cm between the radiator & your body. This transmitter must not be co-located or operating in conjunction with any other antenna or transmitter. ⚠️ The distance between RCOWL and DJI remote controller (RC) should be greater than 10cm when both RCs are turned on.

DEAR CONSUMERS:

OWL is an emergency parachute system developed by Flyfire, which is applicable to MATRICE 300RTK UAV. If you have any questions about the product in use, please send an email to support@idofuture.com, and we will solve it for you as soon as possible.

SAFETY INSTRUCTIONS:

Please read this manual carefully before use. The OWL related parts complies with the relevant regulations of DOT and flight rule lithium battery. ① Please use it in the correct way. Important contents are recorded in this manual to enable you to use the product safely and correctly and to prevent personal injury or property loss to you and others. Please keep it properly so that users of this product can read it at any time.



WARNING INDICATES THAT FAILURE TO FOLLOW THIS INSTRUCTION OR OPERATE IMPROPERLY MAY CAUSE CASUALTIES.



NOTE INDICATES THAT FAILULRE TO FOLLOW THIS INSTRUCTION OR OPERATE IMPROPERLY MAY CAUSE PRODUCT DAMAGE AND PERSONNEL INJURY.



HEADS UP

- It is strictly forbidden to aim the OWL parachute at human body at any time.
- Please do not transport in a violent way and do store it properly.
- Do not open the shell forcibly, if you disassemble the parachute bay by yourself, the parachute will be locked. Please contact the maintenance point to return to the factory for repair and unlocking. Use authorized accessories to install OWL, and follow the installation procedure of the manual. For assembly details and precautions, please refer to the OWL assembly section of the manual.
- When the product is not in use, put it back into the seal box to ensure that it will not be squeezed or be affected with damp during the storage process.
- Please strictly follow the operation instructions of DJI UAV. Please do not use unauthorized accessories in conjunction with the parachute. Please consult local UAV flight laws and regulations before flight.
- Do not block the M300 heat emission hole and install it strictly according to the instructions.
- It is strictly forbidden to place heavy objects on the OWL parachute bay, otherwise it may cause fracture and failure.

- Any damaged parts need to be troubleshoot and evaluated for repair. Please contact the maintenance point.
- During the ground test, personnel are supposed to evacuate to a distance beyond 10m due to the kinetic energy of injury in the launch direction of the parachute. The reacting force may damage the M300. Please do not try to conduct a ground test on the drone.
- Do not expose OWL to direct sunlight, fire or high temperature for long, which may cause product deformation.
- Do not use communication equipment in the same frequency band so as not to interfere with the remote control signal.

WARNINGS

- It is strictly forbidden to point the spraying direction of OWL parachute at the human body at any time.
- It is forbidden to disassemble, repair or modify the parachute, otherwise the product warranty will not be invalid.
- Lithium battery is contained, so improper use of battery will lead to leakage or explosion. Please transport and store it properly.
- Do not open the shell forcibly. If the parachute bay is disassembled by yourself, the parachute will be locked. Please contact the dealer to return to the factory for maintenance and unlocking.
- Non-professionals should not carry out the ground parachute-opening test. Please ensure the safety of personnel before the test.



SINK
RATE **3.5m/s**

■ **WARRANTY SERVICE REGULATIONS**

1) Dear users, thank you for buying the products of Flyfire. With this card and valid invoices or other valid vouchers specified in the warranty, users could enjoy the repair, replacement and return services provided by the authorized service outlets of Flyfire (hereinafter referred to as “service outlets”) in accordance with the relevant national laws and regulations. (hereinafter referred to as “warranty service”)

2) Within 7 days from the purchase of the device, in case of product quality problems with OWL, consumers can choose to refund at one time according to the invoice price or replace OWL of the same model and specification. To apply for a return within 7 days without reason, please make sure that the OWL package is complete and the accessories are complete with no stains and obvious traces of use in the product and its packaging.

3) If there are any quality problems with the OWL within 15 days of purchasing the machine, consumers can return to the service outlets to troubleshoot the problems and replace a brand-new OWL.

4) The warranty term of whole OWL device is one year.

5) This manual will not be reissued once lost, so please take good care of it. In necessity, you can download the electronic version from the official website.

6) This manual assumes no other liability, including, but not limited to, occasional or consequential damage or expected benefits or loss of profits, any liability resulted from work stoppage or damage caused by the use or inability to use the product.

7) The parts replaced in the service outlets will not be returned to users.

Flyfire.

WARRANTY

■ CASES THAT DO NOT MEET THE REQUIREMENTS OF THE WARRANTY SERVICE.

1) Failure to present the warranty card and invoice or other valid documents specified in the warranty.

2) The warranty card is altered or the product is inconsistent with the information on the card.

3) Normal use, wear and aging of the worn materials during the use of the product.

4) Disassembling and assembling voluntarily or dismantling, refitting and repairing by a third party not certified by Flyfire.

5) Failure to use, maintain and store in strict accordance with the requirements of the product manual.

6) Damage caused by force majeure such as accident, flood, lightning strike, fire, etc.

7) The validity period of the warranty service has expired.

■ HEADQUARTER OF AFTER-SALES SERVICE OUTLETS

* Dongguan Flyfire Technology Product Technical Service Center, Building C, Songshan Lake Ecological Park, Shipai Town, Dongguan, China

CONTENTS

FLYFIRE OWL

BEFORE USE

Safety Precautions	4
Provisions on "Three Guarantees"	5
Part Name	8
Quick Assembly Guide	9

OPERATING GUIDE

Safe Start	13
Indicator of Remote Control	14
Indicator of Parachute Bay	15
Tutorial for the Activation of M300 OSDK	16
Code Matching between Parachute Bay and Remote Controller	19
Parachute-opening Mode	20
Ground Parachute-opening Test	21

MAINTENANCE GUIDE

Firmware update	22
Recovery and storage	23
Specification parameter	24

1: OWL PARACHUTE

After opening the package, please check the list of items. (The number in 1 stands for the number of items)

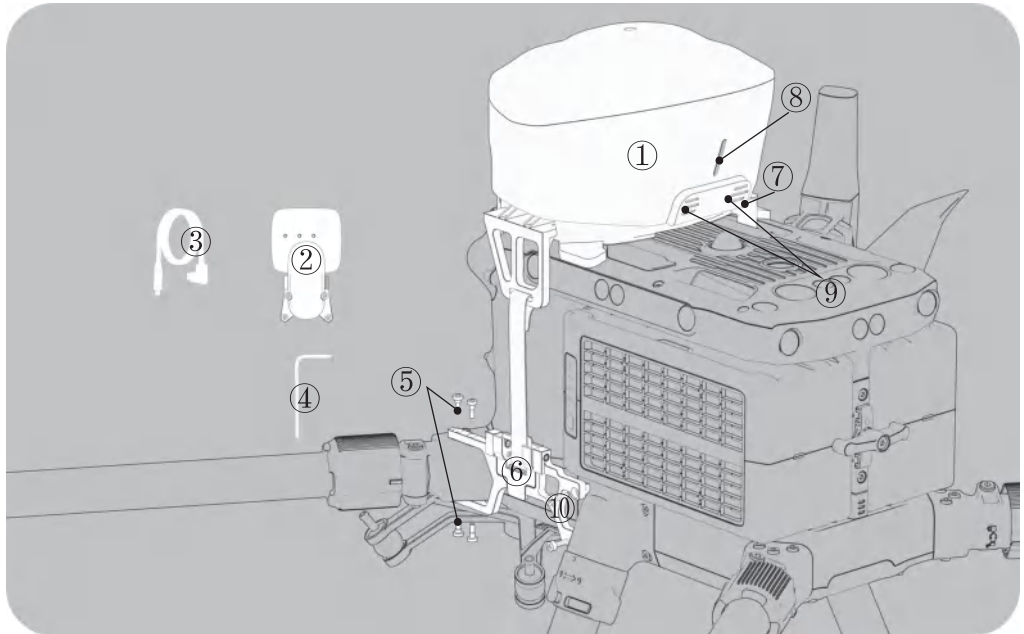

- | | |
|--|--|
| 1 Safe parachute | 2 Remote control |
| 3 Remote control data cable | 4 Hexagon Screwdriver (* 2) |
| 5 Hexagon socket screws (M3X12MM * 4/M3X22MM * 2{ m2.5X10MM * 4 remote control screws, | |
| 6 Self-locking buckle of fixing belt | 7 OSDK connecting cable of parachute bay |
| 8 Indicator | 9 Buzzer |
| 10 Bottom hanger | |

2:OWL QUICK ASSEMBLY GUIDE



SCAN THE CODE TO
WATCH THE VIDEO TUTORIAL

1 Take down the screws for fixing the arm, and install the bottom hanger in place with OWL accessory screws.

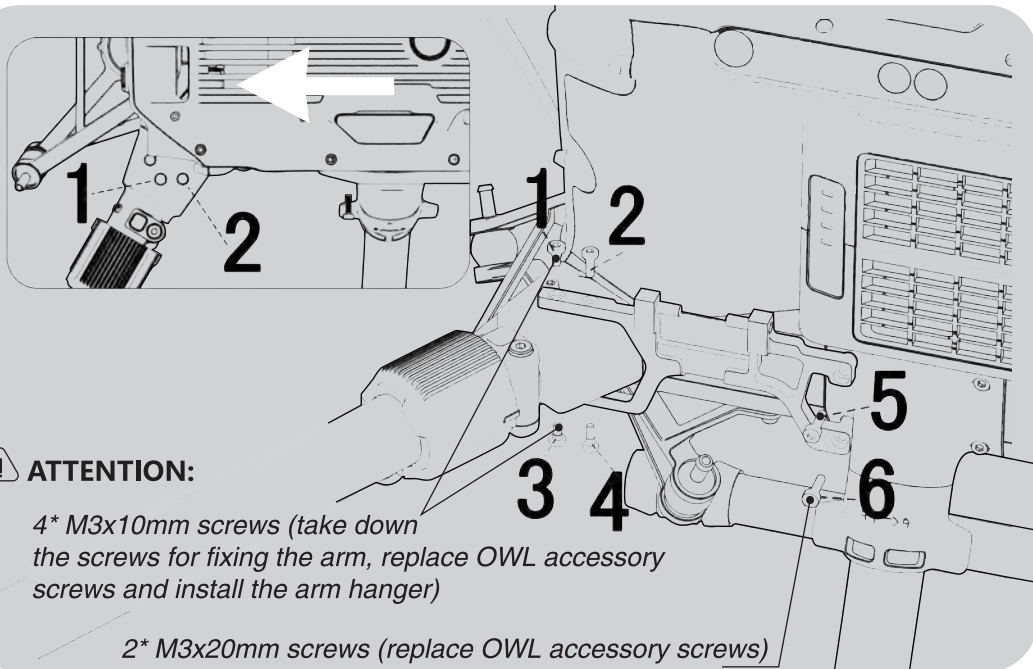

2 Insert the OSDK connecting cable of parachute bay into the OSDK interface of M300.

3 Align the parachute bay with the positioning hole and fix it;

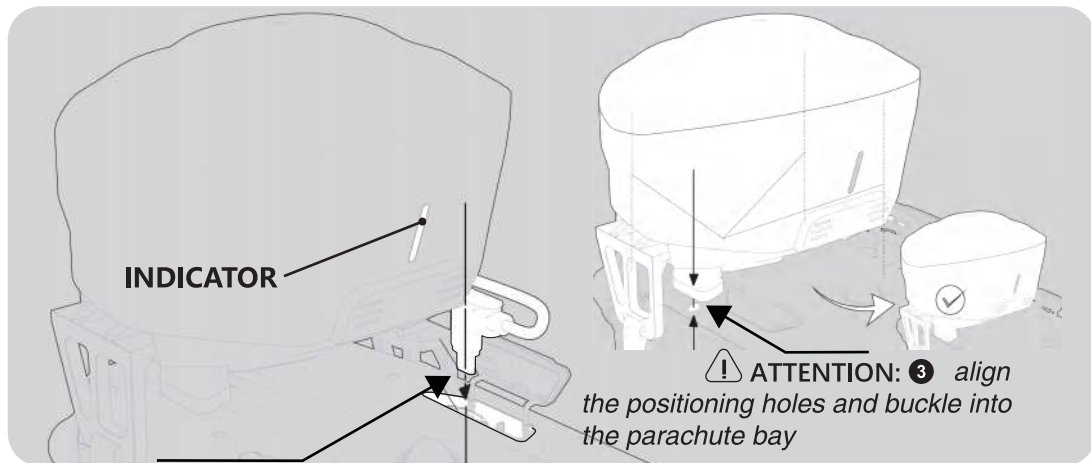

! ATTENTION: 2 insert OSDK interface of M300.

4 Lock the self-locking buckle of the fixing belt of the parachute to the bottom hanger;

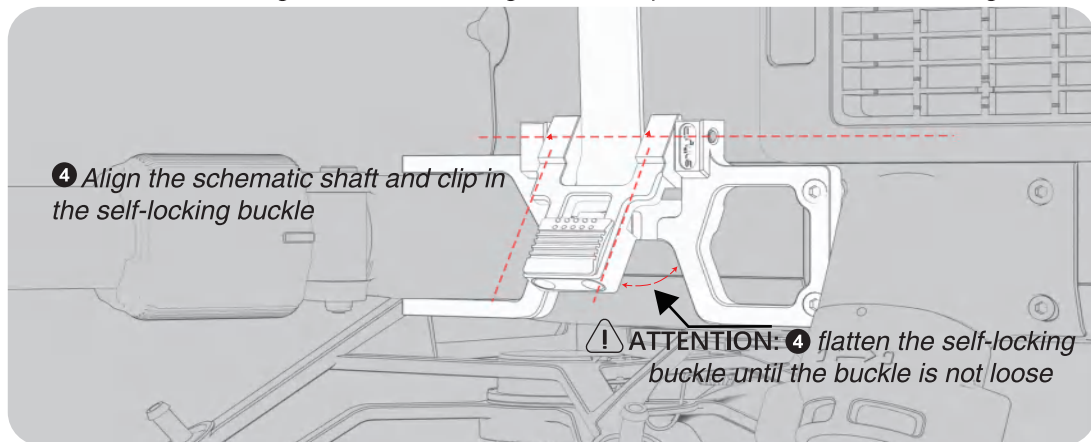

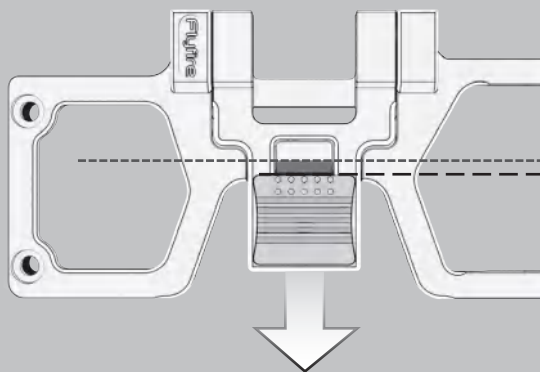

UNLOCK



【PRESS DOWN TO UNLOCK】

⚠ **NOTE:** ④ when installing OWL, please strictly check the self-locking buckle of the arm hanger and fixing belt, so as to ensure that there is no looseness.

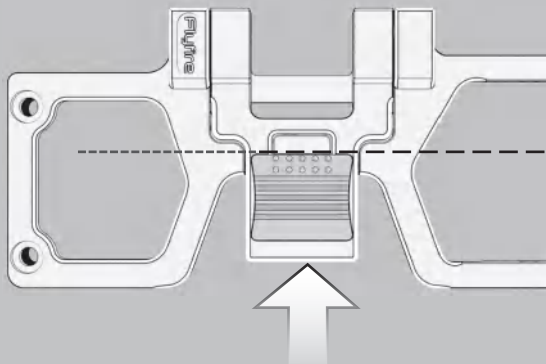

LOCK



【LOCKED】

5 Check after locking, so as to ensure that there is no sign of slippage and looseness in OWL parachute bay.

6 Correctly install the OWL remote control to the M300 remote control and connect USB.

5 **!** *Check whether the parachute bay is loose after the bottom hanger is fully installed.*

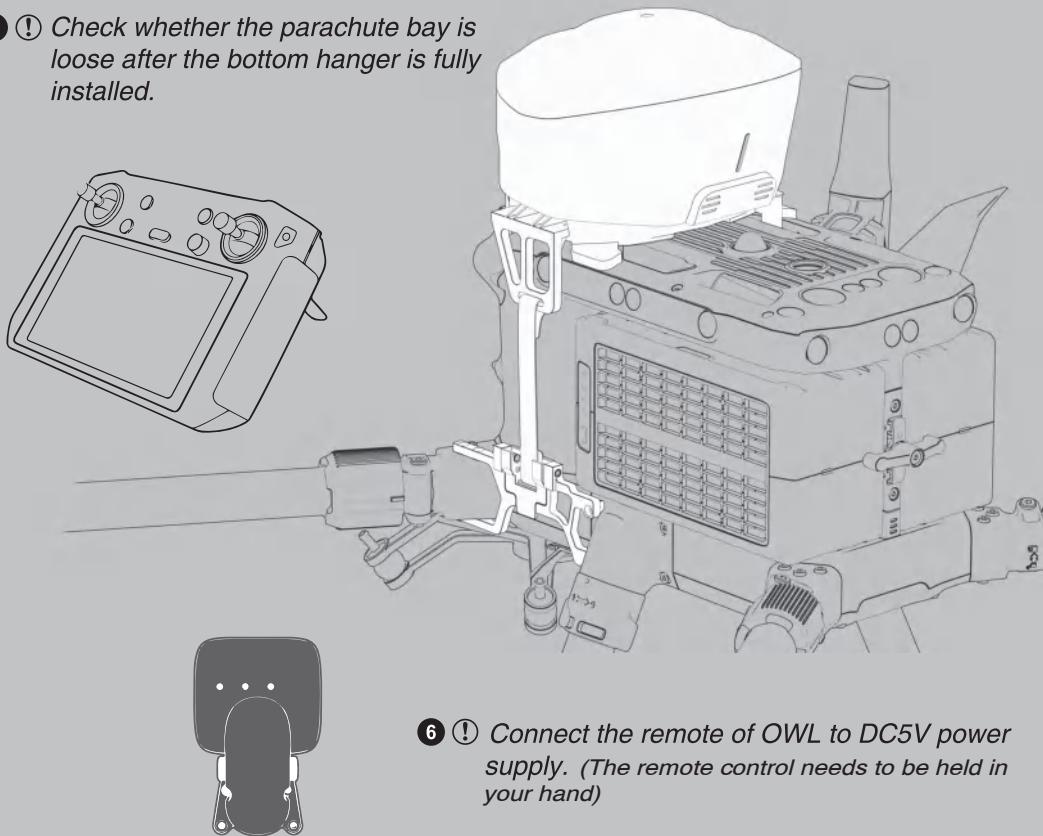

6 **!** *Connect the remote of OWL to DC5V power supply. (The remote control needs to be held in your hand)*

3: SAFE START

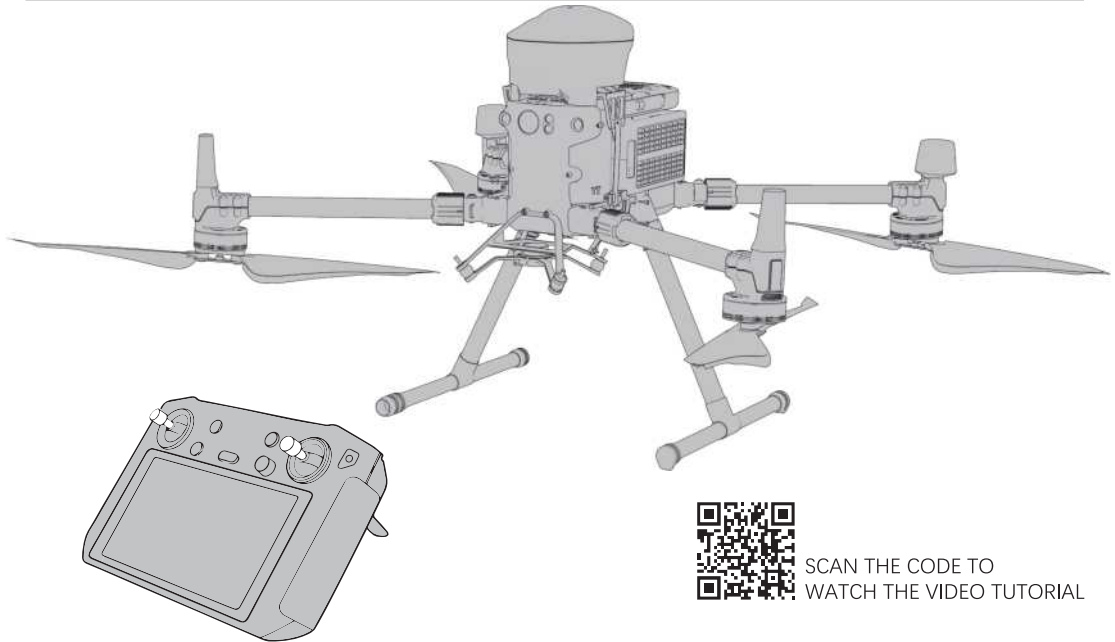

SCAN THE CODE TO
WATCH THE VIDEO TUTORIAL

1) OWL starts automatically after M300 is started. After the initialization of UAV is completed, the indicator light of the parachute bay changes from yellow breathing light to green breathing light. (it has been connected to M300 and the self-checking result is normal, so it can be used for takeoff)

2) Please confirm that the surrounding environment is safe before takeoff.

4:REMOTE CONTROL INDICATOR

Check the status of the parachute/remote control with the indicator light.

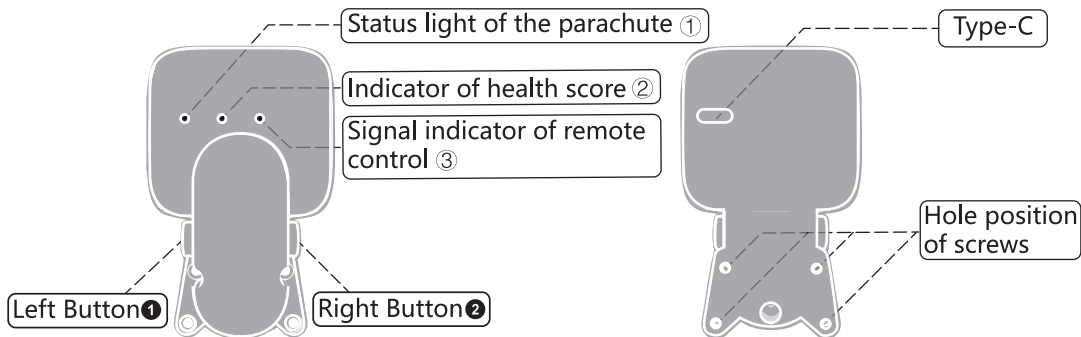

■ STATUS LIGHT OF THE PARACHUTE ①

It is being tested before take-off.

Y Yellow breathing light

The parachute bay and remote control are normal and it can be used to take off.

G Green breathing light

M300 has been lifted off, and it is below the alert height ².(the parachute can be opened remotely, but automatic parachute-opening is not activated)

G Green flashing

M300 has attained the alert height ².(automatic parachute-opening has awakened)

G Green light on

The parachute is locked or opened. ⚠️ WARNING

R Red light on

Code matching succeeded. Please restart the parachute bay and exit the code matching mode.





B Blue light on

The firmware of the remote controller is being upgraded.





O Orange flashing

Wireless connection between remote control and parachute has been disconnected.  Lights off

■ PARACHUTE HEALTH SCORE ②

Safe	 Green light on
Comparatively dangerous.	 Yellow light on
The system judges that M300 is out of control to open the parachute.	 Red light on
The firmware of the remote controller is being upgraded.	 Orange flashing
Wireless connection between remote control and parachute has been disconnected.	 Lights off

■ SIGNAL INDICATOR OF REMOTE CONTROL ③

Entering code matching mode.	 Blue flashing
The signal is normal.	 Green light on
The remote control signal can be connected normally, but the distance is long or the interference is too large.	 Yellow light on
When the remote control signal is disconnected, the remote control sounds once.(not connected to the parachute)	 Red light on
The firmware of the remote controller is being upgraded.	 Orange flashing

5:ORANGE FLASHING

Check various states of the parachute via indicator lights

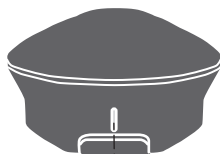

OWL INDICATOR LIGHT

Firmware upgrade of parachute bay.	O Orange flashing
Enter the code matching mode.(refer to Page 18)	B Blue flashing
Code matching between remote control and parachute bay succeeded. Restart parachute to exit code matching mode.	B Blue light on
Connecting to the M300.	Y Yellow breathing light
Connected to M300. Self-check is normal.	G Green breathing light
M300 has taken off and is below the alert height.(automatic parachute-opening is not awakened)	G Green flashing
M300 has taken off and is above the alert height.(automatic parachute-opening is awakened)	G Green light on
Invalid remote control parachute-opening operation.(click the left key to cancel parachute-opening)	R Red flashing
The parachute has been opened or automatically locked.(please contact the maintenance point for unlocking)	R Red light on
M300 OSDK is not activated [®] , please activate OSDK before using it.	Y Yellow flashing

Flyfire OSDK ACTIVATION PROCESS

[Activation requires your PC to have an Internet connection.🌐]

1: Download, install and open the computer.[DJI Assistant 2 For Matrice.]



SCAN THE CODE TO
WATCH THE VIDEO TUTORIAL

2: Connect M300 Type-C debugging interface to computer with a Type-C data cable and start M300.



3: The software displays "connected to the equipment" [latitude and longitude M300 RTK], then click the "Settings" button in the upper right corner of the software.

4:1>Open the "DJI equipment information".

2>Open the "Onboard SDK APP ID".

3>Close the "Settings" page.

Data Authorization

DJI and third party partners will access the following information to ensure that the software functions properly

DJI account information

For device activation, firmware upgrade, data upload, Payload SDK and other services.



DJI device information

For device activation and data upload services



Payload SDK Product ID and License information

For Payload SDK binding and unbinding services



Onboard SDK APP ID

For Onboard SDK activation service

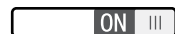

5: Click on [latitude and longitude M300 RTK]

dji ASSISTANT

CONNECTED DEVICES

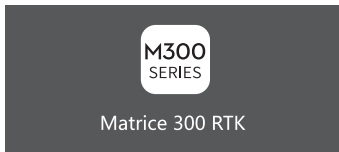

- 6:1 > Click on the "Onboard SDK" Tabs on the left
- 2 > Check the "Start API Control".
- 3 > Select "230400" for "Baud Rate".

DJI Onboard SDK

Enable API Control Ground Station Status Enable SDK Failsafe Action

Baud & Data Transmission Rates

Baud Rate: 230400

Timestamp: Do Not Send

Attitude Quaternions: Do Not Send

Acceleration: Do Not Send

Velocity(Ground Frame): Do Not Send

Angular Velocity(Body Frame): Do Not Send

Position: Do Not Send

GPS: Do Not Send

RTK: Do Not Send

Magnetometer: Do Not Send

Remote Controller Channel Data: Do Not Send

Gimbal Data: Do Not Send

Flight Status: Do Not Send

Battery Level: Do Not Send

Data Type

ACC: Ground Frame Fusion Data

GYRO: Data Fusion

ALTI: Data Fusion

HEIGHT: Altitude to Home Point

SDK Failsafe Action Settings

SDK FAILSAFE ACTION: Hover

MC Output

Privacy Policy
Terms Of Use

English
Login

7: Insert the connection cable of OWL parachute bay into the OSDK expansion interface of M300 (do not disconnect M300 from the computer), and wait for the indicator light of the parachute bay to turn into green breathing light, and then the activation operation is finished. [Activation requires your PC to have an Internet connection.]

6:CODE MATCHING BETWEEN PARACHUTE AND REMOTE CONTROL

! NOTE: when multiple parachutes are used within one kilometer, please open parachutes remotely with different frequency bands.

1. Invert the parachute bay and connect the OSDK cable of the parachute bay to the M300 OSDK port, then start M300, and the blue light of the parachute bay indicator flashes.(The parachute bay has entered the code matching mode)
2. Press the right key of the remote control for 10 seconds, and the signal indicator ③ of the remote control will turn blue. At this time, right-click to switch different frequency bands, and wait for the blue light to flash after determining the frequency band.(The remote control has entered the code matching mode of this frequency band)
3. The indicator light of the parachute bay and the indicator light of the remote control in this frequency band turn blue and normally on, and both sound once. (The signal between the remote control and the parachute bay has been connected normally, and the code matching succeeded)
4. Disconnect the OSDK connecting cable of the parachute bay, exit the code matching mode, and install OWL following the steps. (The code matching steps have been finished, and please start using your OWL)



SCAN THE CODE TO
WATCH THE VIDEO TUTORIAL

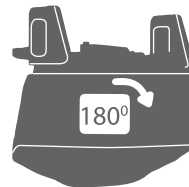
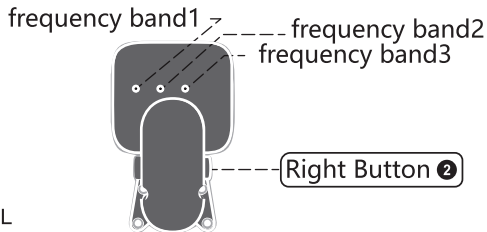

After the code matching is finished, it is necessary to restart the parachute bay, restart the M300 UAV or re-plug the OSDK connecting cable of parachute bay to exit the code matching mode.

Note: The frequency band of remote control ③ has been set before leaving the factory. If multiple parachutes are used within one kilometer, please select parachute-opening signals of remote control in different frequency bands.

Flyfire.

PARACHUTE-OPENING MODE

7:PARACHUTE OPEN MODE

{1} OWL AUTOMATIC PARACHUTE-OPENING MODE

 Program judgment ④, automatic parachute-opening in case of danger.

{1} OWL REMOTELY CONTROLLED PARACHUTE-OPENING MODE.

 Open the parachute by remote control in case of emergency, and open the parachute by remote control in the air by double-clicking the left key and right key simultaneously. (Note: Ensure the safety height is 25m or above ⑤)

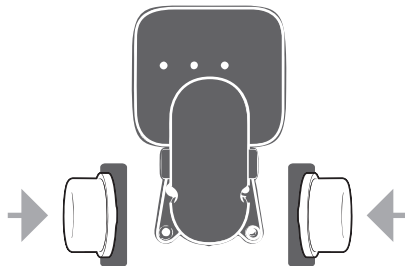

 **NOTE:** Double-click the left key ① and right key ② simultaneously to open the parachute remotely in the air.

 Before M300 takes off, the parachute-opening operation of manual remote control is invalid; at this time, double-click the parachute-opening button, and the red indicator of the parachute bay flashes to report an error; click the left key to exit this mode.

GROUND PARACHUTE-OPENING MODE

8: GROUND PARACHUTE-OPENING TEST (Do not conduct ground test by carrying on M300)

 **WARNING:** This test is faced with certain safety risks, so non-professionals are forbidden to operate it. Please carry out this experiment while ensuring the safety of personnel.

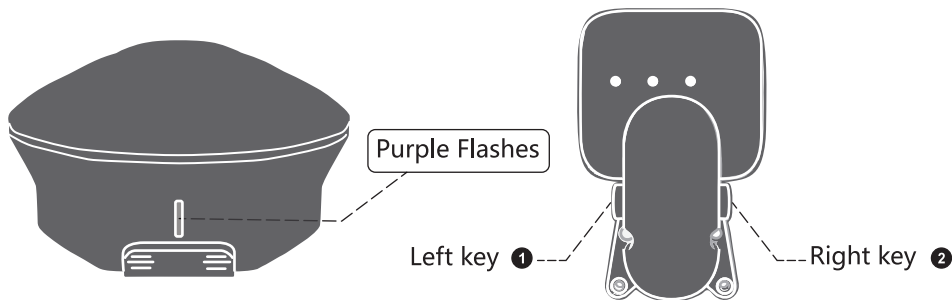
 **STEPS OF GROUND TRIGGER TEST MODE**

1: Evacuate to a safe area, by pressing the right key **2** for ten consecutive times, the indicator light of the parachute bay turns purple and flashes. At this time, it has entered the preparation state of ground parachute opening. (Note: click the left key **1** to exit the ground parachute opening mode at this time)

2: Double-click the left and right keys simultaneously to open the parachute on the ground. After opening the parachute, please cut off the power (unplug the OSDK connecting cable of parachute bay) to turn off the parachute buzzer.

3: After the test is finished, please contact replace the worn parts and refill them at the maintenance point.

9: UPDATE



SCAN THE CODE TO
WATCH THE VIDEO TUTORIAL

1> To ensure the smooth upgrade of the remote control, before upgrading, make sure that the remote control and OWL parachute bay can be connected normally! (This step can be omitted without the remote control version)

2> Log in to the official website of Flyfire WWW.IDOFUTURE.COM, click [Download] in the navigation bar, and select the latest firmware of OWL and download it to the local hard disk.

3> Connect M300 remote control with OWL remote control and start it, and connect OWL parachute bay and computer by using USB Type-C data cable.

Correct connection: when the indicator light of OWL parachute bay turns blue, the computer prompts that a new USB flash drive is connected, and then copy the file to the root directory of the USB flash drive.

Wrong connection: when the indicator light of OWL parachute bay turns white, please change the direction of Type-C interface and try again.

4> After the file transfer is finished, do not disconnect the Type-C data cable, and the OWL parachute bay will automatically start firmware upgrade. During the process, the indicator light of OWL parachute bay flashes orange.(During which the upgraded firmware will be transmitted to the OWL remote control)

5> OWL remote control automatically starts upgrading, during which the indicator lights of remote control (all) flash in orange, suggesting that the upgrade is in progress. After the upgrade is finished, the indicator lights of remote control will turn green.

6> When the light of OWL parachute bay turns white, at this time, the connection between the parachute bay and the computer can be disconnected, and the firmware upgrade is finished.

NOTE: During the upgrade, please do not cut off the power of the parachute bay and remote control, and keep the parachute bay and remote control within 10 meters; otherwise, the upgrade may be unsuccessful. After the firmware upgrade is finished, the indicator light of the parachute bay and the remote control will turn white. This status suggests that the upgrade is finished and the connection can be disconnected.

Flyfire.

RECYCLING AND STORAGE

10: RECYCLING AND STORAGE

 NOTE: when not in use for a long time, please place OWL in a sealed box.

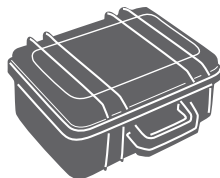

DAMP



HIGH TEMPERATURE



DISASSEMBLY



SQUEEZING

Please keep away from damp, high temperature and places with fire hazards during storage. At any time, it is forbidden to allow users to disassemble OWL parachute bay by themselves, which will do irreversible damage to OWL products. Should the above situation happens, please send it back to the designated dealer for unlocking and maintenance.

Please check this manual when there is any problem or query.

We will inform you of the application update and the latest version number by email. For more information, please refer to the following website: WWW.IDOFUTURE.COM

SPECIFICATION PARAMETERS

Area of parachute fabric	7. 29m ²	Application	MATRICE 300 RTK
NET weight	780g ^⑥	Working temperature	-20°C ~50°C
Volume	19dm ³	Working altitude	≤3500M
		Reaction Time	500 ~700ms
		Reaction distance	8. 59m~20. 96m
MATRICE 300 RTK (9kg)		Protection grade	IP45
The lowering speed of OWL parachute-opening test is 3.5m/s ^⑦		Classification of wind resistance	W-7

-
- ① The OWL Gas Generator met the DOT (US Department of Transportation) UN 6(d) test criteria, and the lithium battery met the UN38.3 test report criteria.
 - ② The alert height is 15 meters. If it is lower than the alert height, the parachute can be opened remotely, but the parachute will not be opened automatically. Flyfire with a height below 15 meters cannot ensure that the parachute fabric is fully unfolded to fulfill the ideal slow-down effect. Please open the parachute manually with caution.
 - ③ Lease unlock OSDK, otherwise the parachute will not be connected to M300.
 - ④ When dangerous situations such as power loss and impact occur during the flight of M300, automatic parachute opening will be triggered.
 - ⑤ Twenty-five meters is the safety height. The greater the height value, the higher the success rate of airplane rescue will be.
 - ⑥ Net weight of parachute bay.
 - ⑦ This reduction of speed is the average value of multiple times of measurements.

Flyfire[®]

WWW.IDOFUTURE.COM

Manufacturer: Dongguan Flyfire Technology

Address: Dongguan Flyfire Technology Product Technical Service Center,
Building C, Songshan Lake Ecological Park, Shipai Town, Dongguan, China





ITEM LIST

Before using this product, please check whether the product package contains all of the following items. If anything is missing, please contact Flyfire or your local agent.



X1

OWL parachute bay



X1

Remote control data cable



X1

Remote Control



X2

Bottom hanger



X1

Parachute bay protective cover



X16

Screw



X2

Screwdriver

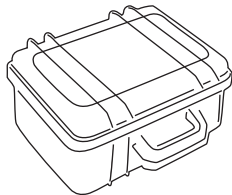

X1

Seal box

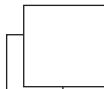

X1

Product manual and warranty

Flyfire.



F20210125

火萤公司
中国印刷