

# Antenna Performance

## ▪ Radiation Pattern and Gain

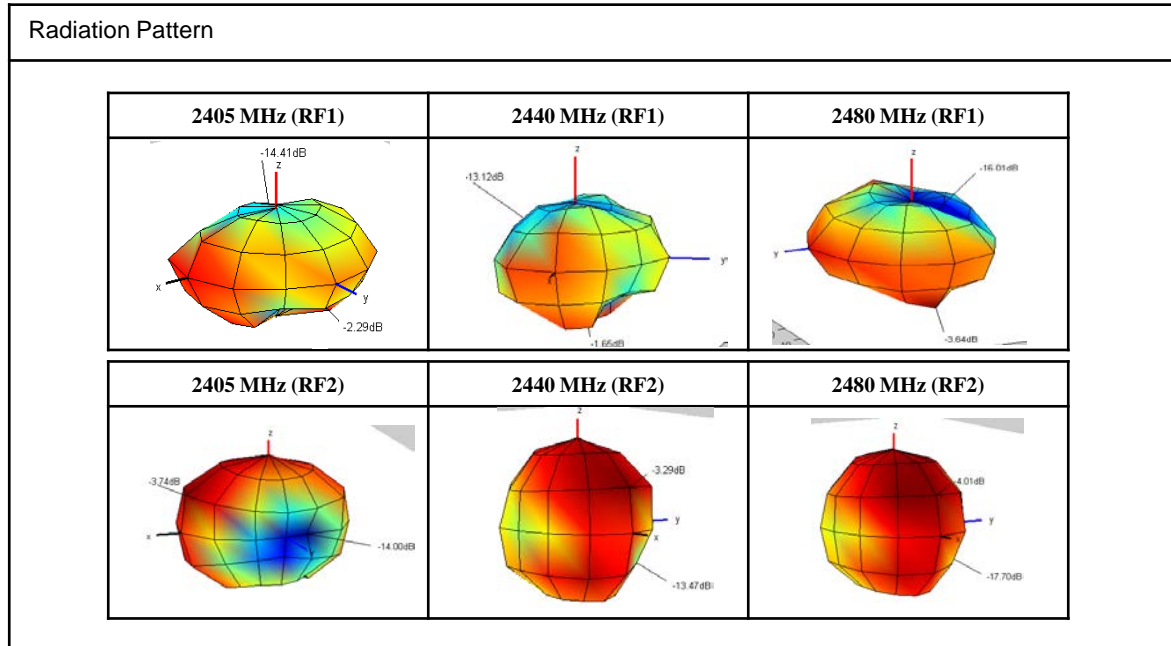
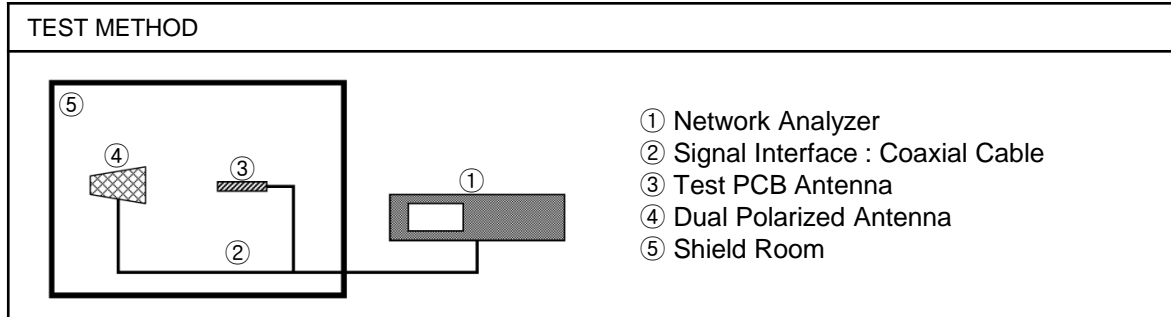

Efficiency

	RF1				RF2			
	2405	2440	2480	TOTAL	2405	2440	2480	TOTAL
Frequency(MHz)	2405	2440	2480	<b>TOTAL</b>	2405	2440	2480	<b>TOTAL</b>
Efficiency(dB)	-6.75	-6.56	-8.15	<b>-7.06</b>	<b>-6.89</b>	<b>-6.33</b>	<b>-7.11</b>	<b>-6.72</b>
Efficiency(%)	21.1	22.1	15.3	19.68	20.6	23.3	19.5	21.29