

Antenna Performance

▪ Radiation Pattern and Gain

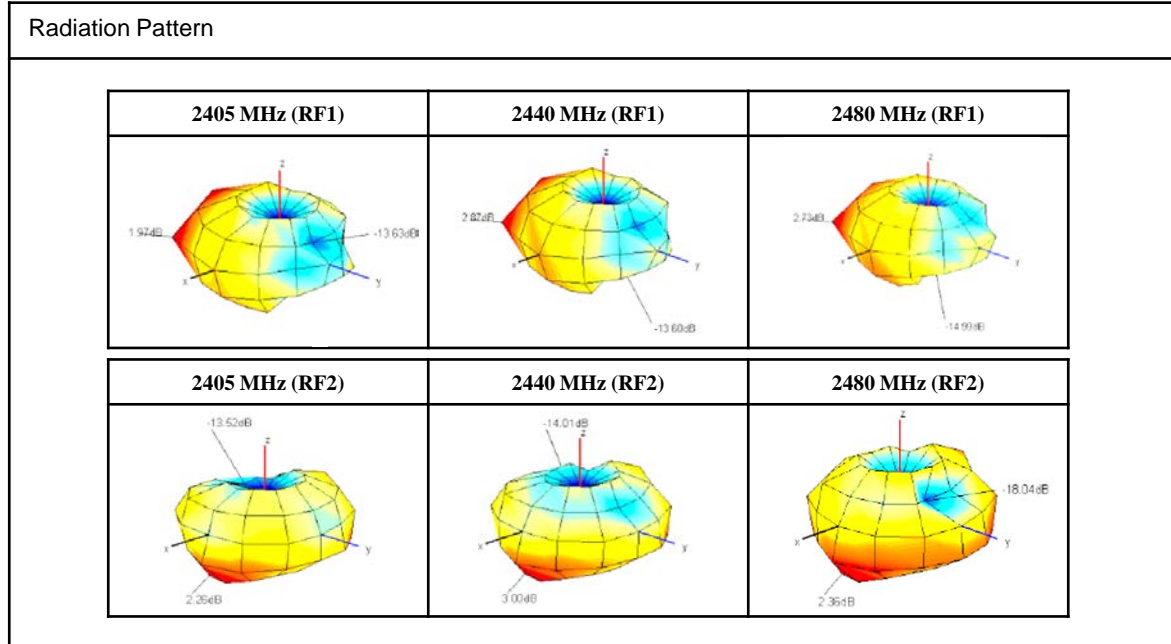
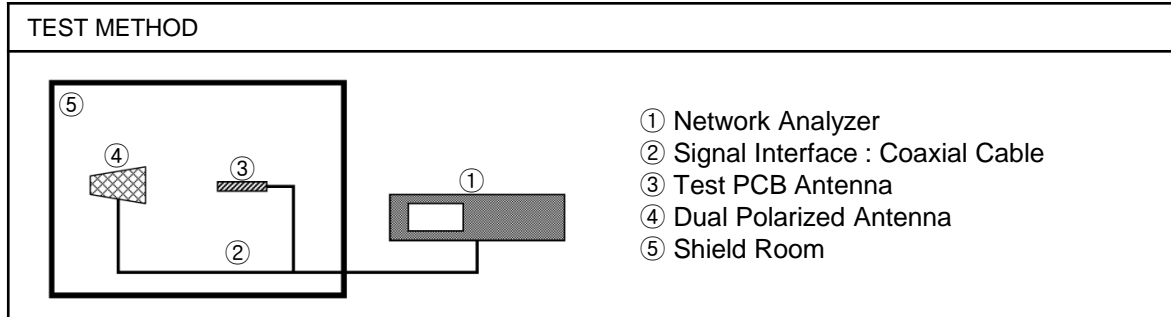

Efficiency

	RF1			RF2		
	2405	2440	2480	2405	2440	2480
Frequency(MHz)	2405	2440	2480	2405	2440	2480
Efficiency(dB)	-3.78	-3.07	-3.50	-3.98	-3.69	-3.93
Efficiency(%)	41.84	49.28	44.65	39.96	42.77	40.46