

Antenna Performance

▪ Radiation Pattern and Gain

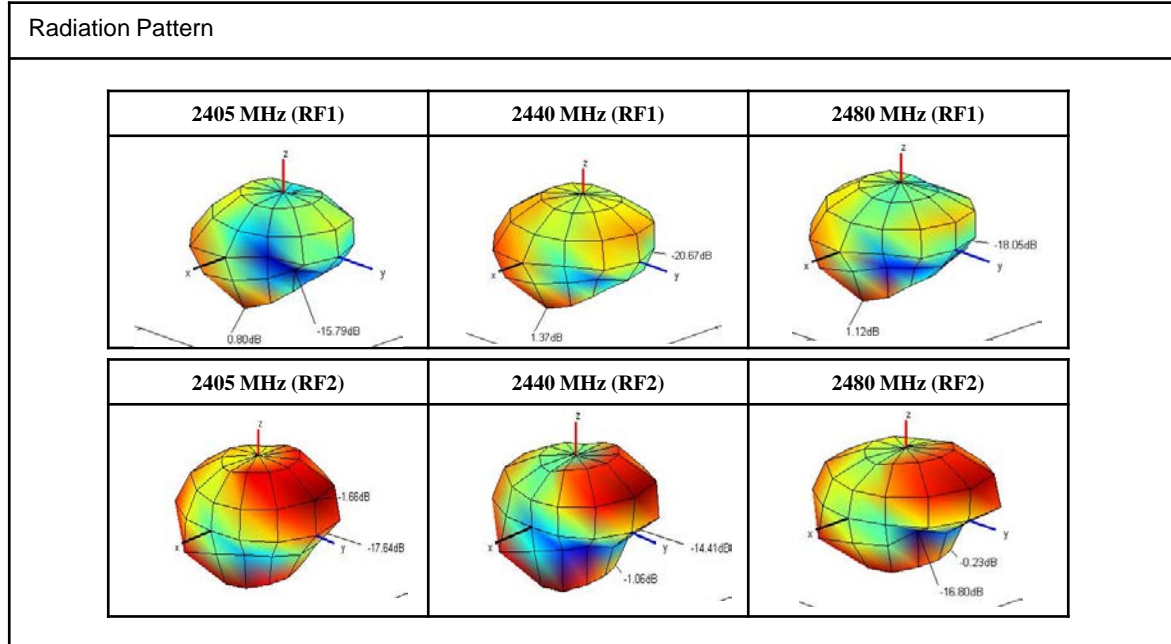
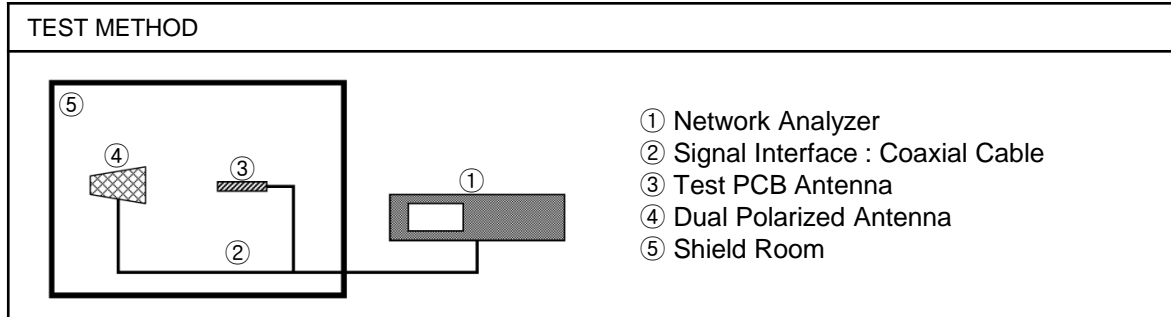

Efficiency

	RF1				RF2			
	2405	2440	2480	TOTAL	2405	2440	2480	TOTAL
Frequency(MHz)	2405	2440	2480	TOTAL	2405	2440	2480	TOTAL
Efficiency(dB)	-6.99	-6.46	-6.85	-6.82	-5.84	-5.46	-5.18	-5.58
Efficiency(%)	20.0	22.6	20.6	20.82	26.1	28.4	30.3	27.69