

CUSTOMER : Standard

DATE : 2020. 06. 22

REV : Rev. 1.0

SPECIFICATIONS FOR APPROVAL

REBE-TZ29C

Model	Part Number	Customer P/N
2.9" 3-Color Graphic LED	REBE-TZ29C	-



APPROVAL	REMARK	APPENDIX

DESIGNED	CHECKED	APPROVED
2020.06.19	2020.06.19	2020.06.22
K.S.AN	H.H.HAN	I.U.KIM

TABLE OF CONTENTS

1. Application	3/21
2. Quality	3/21
3. Appearance and Characteristics	3/21
4. Overall Service Scenario	4/21
5. General Features	5/21
6. Absolute Maximum Rating	7/21
7. Electrical Specification	8/21
8. Mechanical Information	9/21
9. Packaging	13/21
10. User Quick Manual	16/21
11. RoHS Compliance	18/21
12. Related Certification	19/21
13. Disclaimers	20/21
14. Ordering Information	21/21

1. Application

This Specification is applied to ATEC IOT Wireless Electronic Shelf Label. (REBE-TZ29C)

REBE-TZ29C is used by retailers for displaying product pricing on shelves. Typically, electronic display modules are attached to the front edge of retail shelving. These modules use Electrophoretic Display (EPD) or similar screen technologies to show the current product price to the customer.

A communication network allows the price display to be automatically updated whenever a product price is changed.

2. Quality

Quality should meet each condition which mentioned on this specification. However, the items which are not mentioned on this specification follow the inspection agreements and standards which are agree with both companies.

3. Appearance and Characteristics

3.1. Appearance

Appearance should not be contaminated by harmful materials and should not have cracks, etc. Mechanical dimensions should meet the contents of clause 9.

3.2. Characteristic

Electrical Characteristics should meet the contents of clause 7.

4. Overall Service Scenario

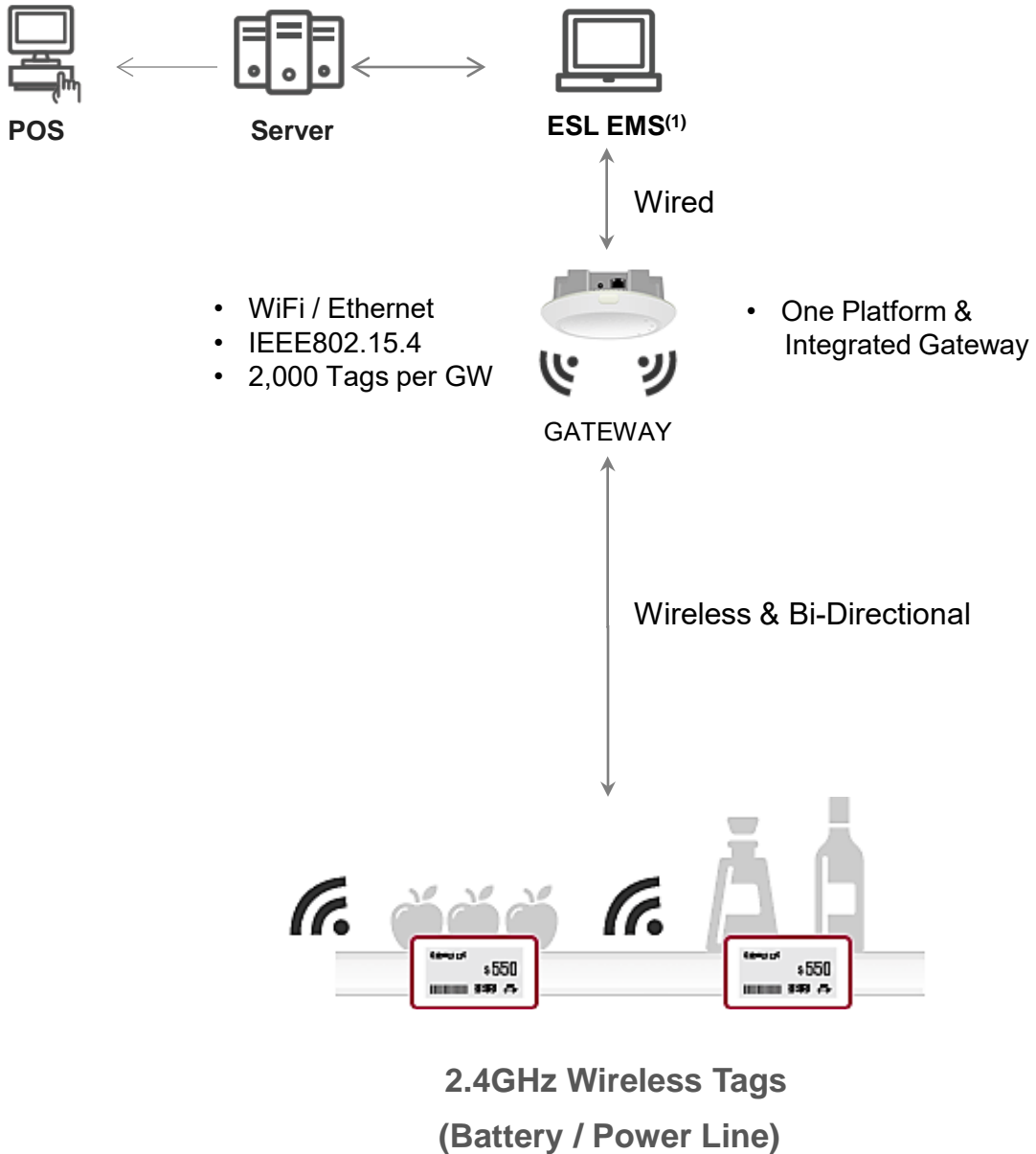

(1) EMS : ESL Management Software

5. General Features

5.1. Description

Item	Description	
Size	90.3 x 42.3 x 12.5 mm	
Weight	Typ. 48.8g (Include Battery - Battery 13.5g)	
Digital Display	Type : Electrophoretic Display Size / DPI : 66.9(H) x 29.06(V) (mm) / 112	
Display Color	3-Color (Red/Black/White) ⁽¹⁾	
Indicator Color	3-Color (Red/Green/Blue) ⁽²⁾	
Power	Rate : 3.0 V / 100 mA CR2450 Coin Battery 2in1 PKG* 1 set (Removable) Battery Capacity : Max. 1,100 mAh Battery life time: 5 year at 23 °C and 55% RH ⁽³⁾ (Image update 2 times per day)	
NFC	Operating frequency of 13.56 MHz	
Network	802.15.4	2.4GHz IEEE802.15.4 compliant RF Transceiver
	Security	Robust wireless network (ATEC IOT own protocol)
	Protocol	Compatible with ATEC IOT protocol communication devices
	Comm. Range	Max. 30m (Under LoS) ⁽⁴⁾⁽⁵⁾

- [Notice]** (1) If the background of display is red, display quality can be decreased.
Generally, we recommend that the portion of red color has less than 50%.
- (2) The LED luminous intensity depends on operating voltage.
- (3) The battery life time depends on operating conditions
(Temperature, humidity, wireless environment, image update count, Indicator...etc)
- (4) LoS (Line of Sight) : Without any sort of an obstacle between a gateway and end devices.
- (5) Communication Range depends on surrounding environment.

6. Absolute Maximum Rating

6.1. Environmental Conditions

The normal operating environmental conditions are those as below. In such conditions, ESL must be in conformity with the present specification. The conformity to such requirement must be certified by the manufacturer.

Parameter	Condition	Min.	Typ.	Max.	Unit
Operating Environment	Temperature	10	23	30	℃
	Humidity	45	55	65	%RH
Storage Environment	Temperature	0	23	40	℃
	Humidity	45	55	65	%RH

- [Notice]**
- (1) Tag can operate at 0~40℃. But only assure the image quality of EPD at 10~30℃.
 - (2) Depending on the characteristic of the EPD, it may become reddish by passing time.
 - (3) Moisture and liquid can damage the tag and reduce its life time.
 - (4) Getting a magnetic close to the tag can be degraded the performance.
(wireless communication, remote controller, etc)
 - (5) When storing the tag, change it to a white screen, and maintain the proper temperature and humidity.
 - (6) After receiving the product, it should be installed within 3 months.
 - (7) The display glass may break when it is dropped or bumped on a hard surface.
(fragile by external impact)

6.2. Electrical Conditions

The operating electrical conditions are those as below. In such conditions the ESL must be in conformity with the present specification. All devices can be damaged or non-operated over the specification as below. The conformity to such requirement must be certified by the manufacturer.

Parameter	Condition	Min	Typ.	Max	Unit
Supply Voltage	DC Power Supply	2.3	3.0	3.3	V
Power Consumption	@ 3.0~3.3V	-	-	100	mA
ESD Protection	Air Condition @Soft Fail	-8	-	+8	kV

7. Electrical Specification

7.1. IEEE802.15.4

The REBE-TZ29C supports IEEE802.15.4.

7.2. General Specification

- Standard : Only IEEE802.15.4 PHY
- Frequency : 2405 ~ 2480MHz
- Channel : 16CH. (5MHz Spacing)
- Modulation : DSSS/O-QPSK
- Max. Data Rate : 250Kbps

7.3. Electrical Specification

- Channel power depend on each country regulations (EX. KC, etc)
- The electrical specification which is shown below is ATEC IOT internal specification.
- All values depend on surrounding environment and current statement of access point

RF Performance					
Parameter	Condition	Min	Typ	Max	Unit
Output Power	-	-24	-	-	dBm
Receiver Sensitivity	PER=1% (Required -85dBm)	-85	-	-	dBm
Maximum Input Level	PER=1% (Required -20dBm)	-	-	-20	dBm
Frequency Tolerance	Required Max. ± 75 kHz	-75	-	75	kHz
Error Vector Magnitude	Required Max. 22%	-	14	22	%





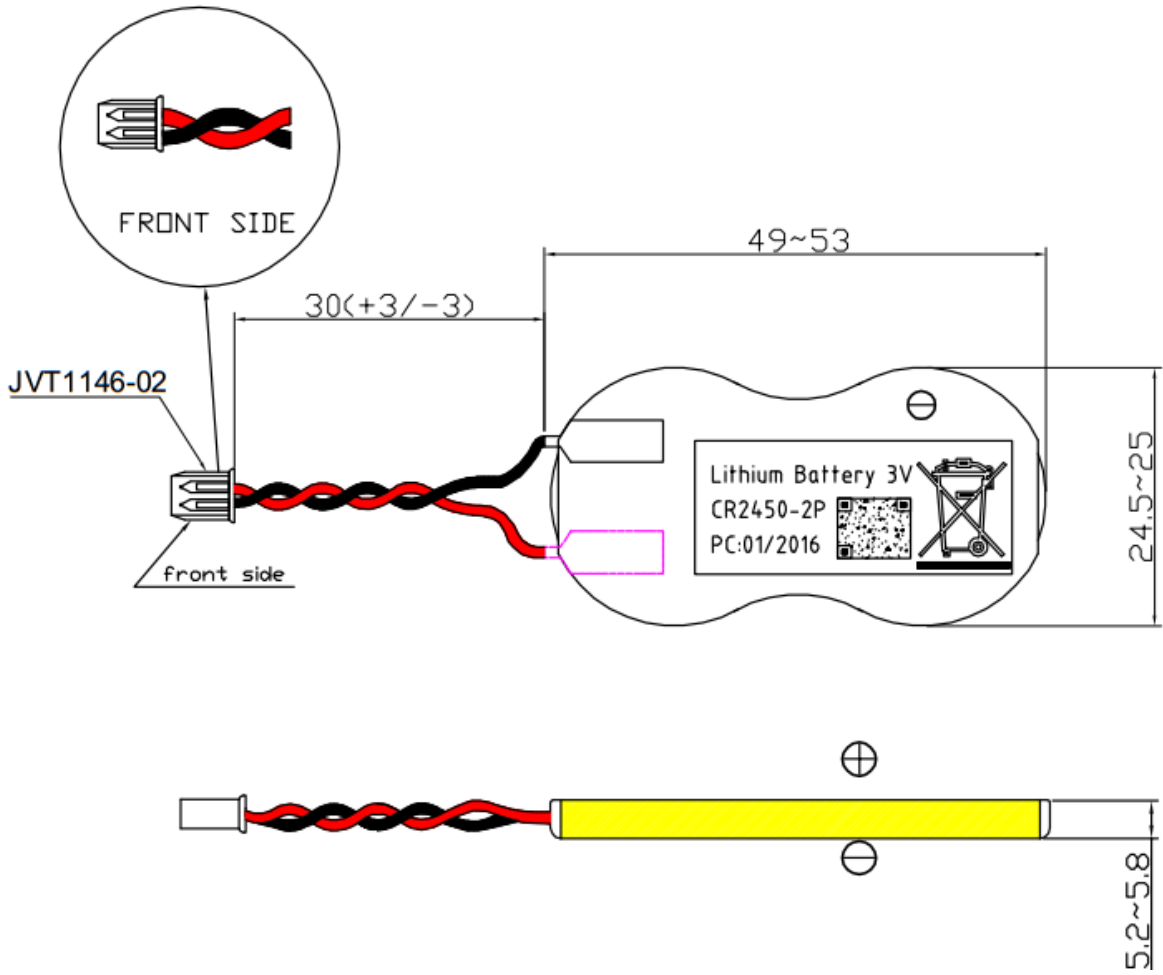







8. Mechanical Information

8.2. Battery Dimension



10. User Quick Manual

10.1. Tag Information

Symbol	Mode	Function	Image
	Deep Sleep	Initial Mode	
	Connected	Connected to Gateway	
	Disconnected	Disconnected to Gateway	
	Low Battery	Battery replacement alarm	
	Empty Battery	Battery Discharged	
	Busy	Ready to image download	

[Notice]

- * In this status of low battery, we can not ensure any normal operations.
- * After change battery, the tag's display will be changed to normal status within next keep alive interval

10.2. Description & Key Function

Remote control device provides customer with several functions as below

- Waking Tag up from sleep mode
- Updating new purchase image on Tag
- Deleting purchase image on Tag
- Returning a Tag to be factory settings

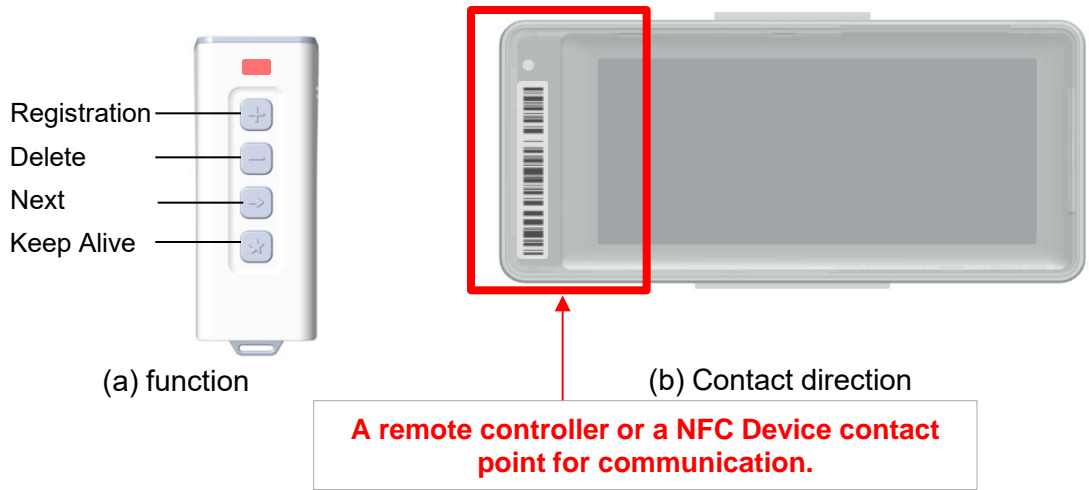

< Remote control device >

11. RoHS Compliance

REBE-TZ29C devices meet the requirements of Directive 2002/95/EC of the European Parliament and of the Council on the Restriction of Hazardous Substance (RoHS)

13. Disclaimers

- *ATEC IOT* is not responsible for any damages caused by any accidents or operational environments exceeding the absolute maximum ratings.
- Consultation with *ATEC IOT* is recommended for unassured environments or operations to avoid any possible malfunctions or damages of the products or risk of life or health.
- Any unauthorized, without prior written consents from *ATEC IOT*, disassembly is prohibited if purposed for reverse-engineering. All defected devices must be reported to *ATEC IOT* and not to be disassembled or analyzed.
- The product information can be modified and upgraded without prior notice.

ATEC IoT CO., LTD.

Model : REBE-TZ29C

Rated Voltage : 3 V

FCC ID : 2AZKWREBE-TZ29C

Made in CHINA

a. Rule Part 15.19(a)(3): This device complies with part 15 of the FCC Rules. Operation is subject to the following two conditions: (1) This device may not cause harmful interference, and (2) this device must accept any interference received, including interference that may cause undesired operation.

b. Rule Part 15.21: The users manual or instruction manual for an intentional or unintentional radiator shall caution the user that changes or modifications not expressly approved by the party responsible for compliance could void the user's authority to operate the equipment.

This equipment has been tested and found to comply with the limits for a Class A digital device, pursuant to part 15 of the FCC Rules. These limits are designed to provide reasonable protection against harmful interference when the equipment is operated in a commercial environment. This equipment generates, uses, and can radiate radio frequency energy and, if not installed and used in accordance with the instruction manual, may cause harmful interference to radio communications. Operation of this equipment in a residential area is likely to cause harmful interference in which case the user will be required to correct the interference at his own expense