

Benutzerhandbuch | Manuel d'Utilisation | Manual del usuario |
Manuale d' Utilizzo

User Manual

SOLAR POWER PANK

MODEL: T1IPWX

[U358]

✉ : chargers@support20h.com

f : Top Outdoor Products Support

Kindly Remind:

If you encounter a problem when using this product, but the return window has been closed. You can contact us via the [Service Email \(chargers@support20h.com\)](mailto:chargers@support20h.com), we will send you a Replacement or Refund.



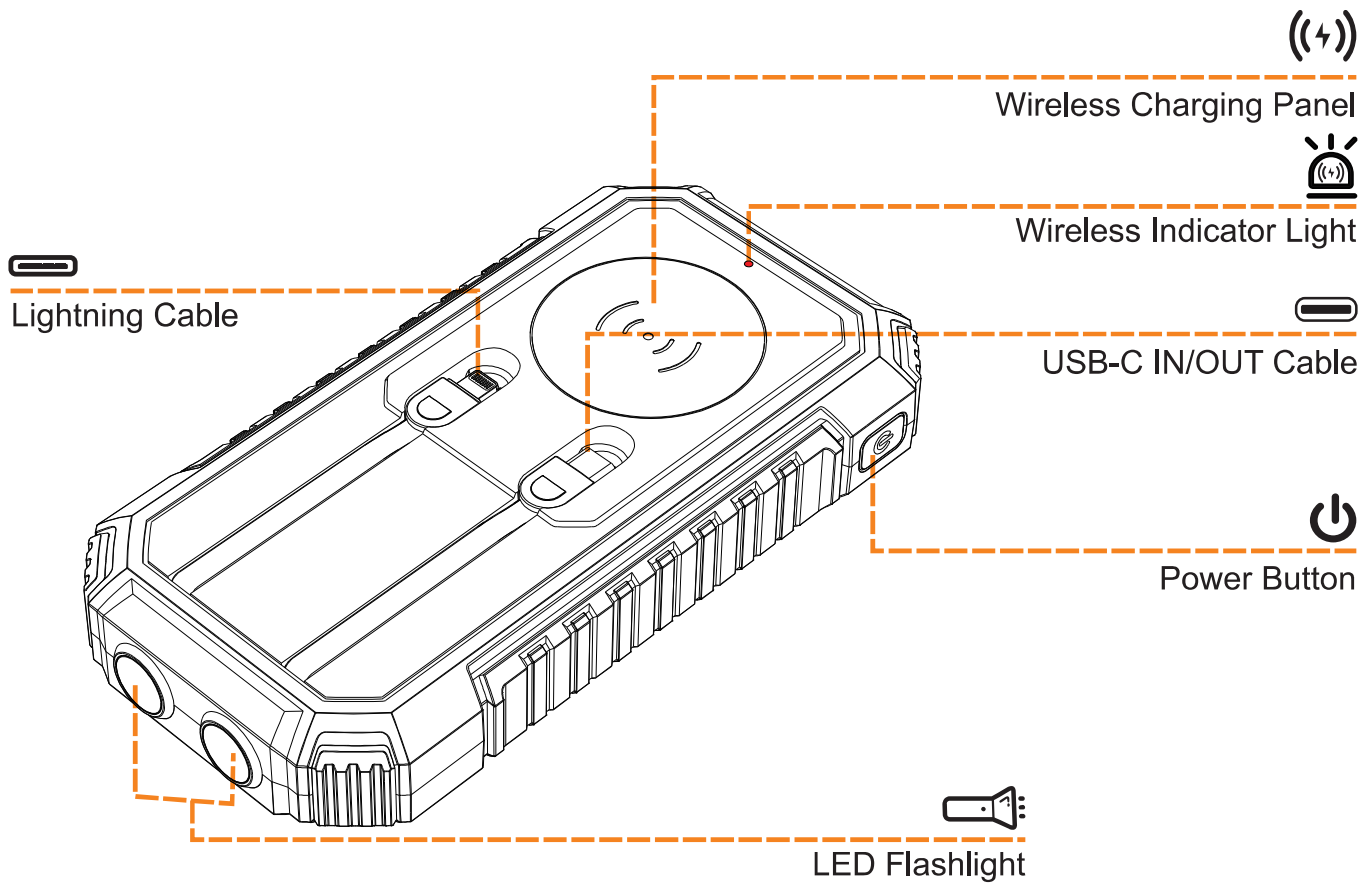
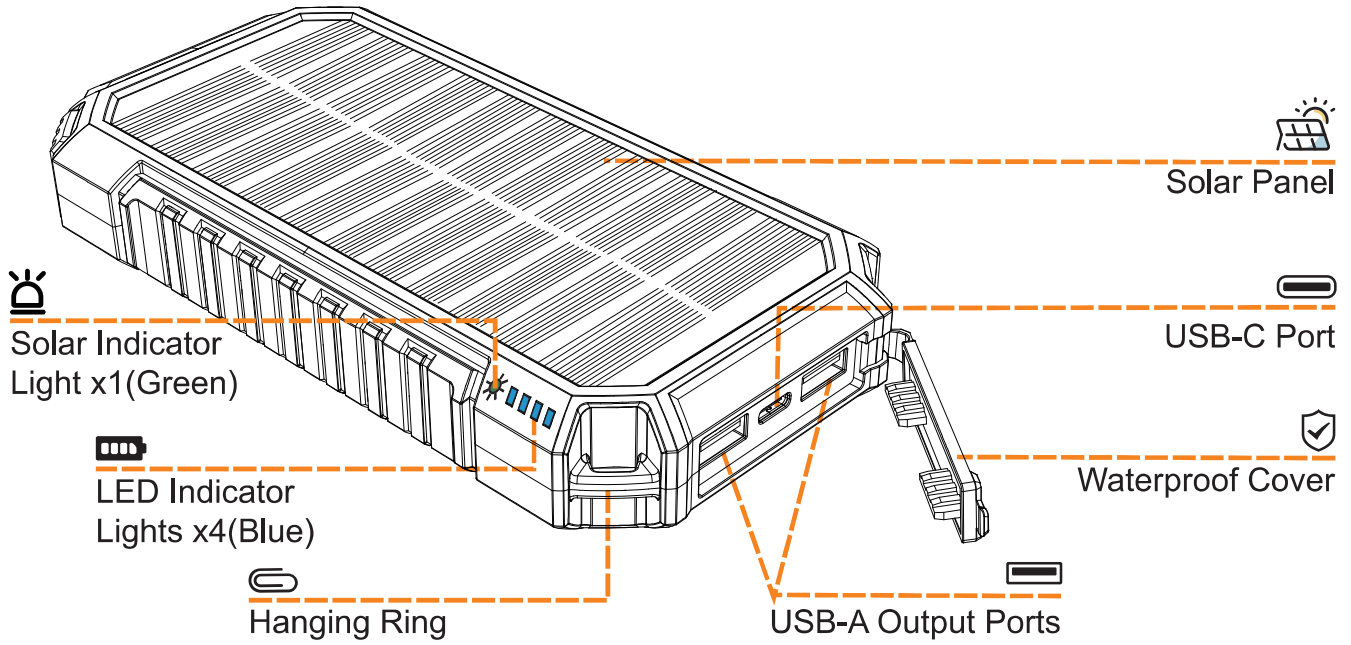

Layout

DE: Layout | FR : Disposition | ES : Diseno | IT: Layout



Specification

DE : Spezifikation | FR : Spécification | ES: Especificación | IT: Specifiche

Item	T11PWX
 Solar panel	1.9W
 Output	OUT1: 5V=3A 9V=2.22A 12V=1.67A OUT2: 5V=3A OUT3: 5V=3A 9V=2A 12V=1.5A 5V=4.5A 4.5V=5A OUT4: 5V=2.4A OUT5: 5V=3A 9V=2.22A 12V=1.67A
 Input	IN1/2: 5V=3A 9V=2A 12V=1.5A
 Wireless charger	15W(MAX)
 Dimensions	6.93X3.50X1.17in (176X89X29.6mm)

LED Flashlight with 3 Modes.

DE: LED Taschenlampe mit 3 Stufen.

FR: Lampe de poche à LED avec 3 modes.

ES: Linterna LED con 3 modos.

IT: Torcia a LED con 3.

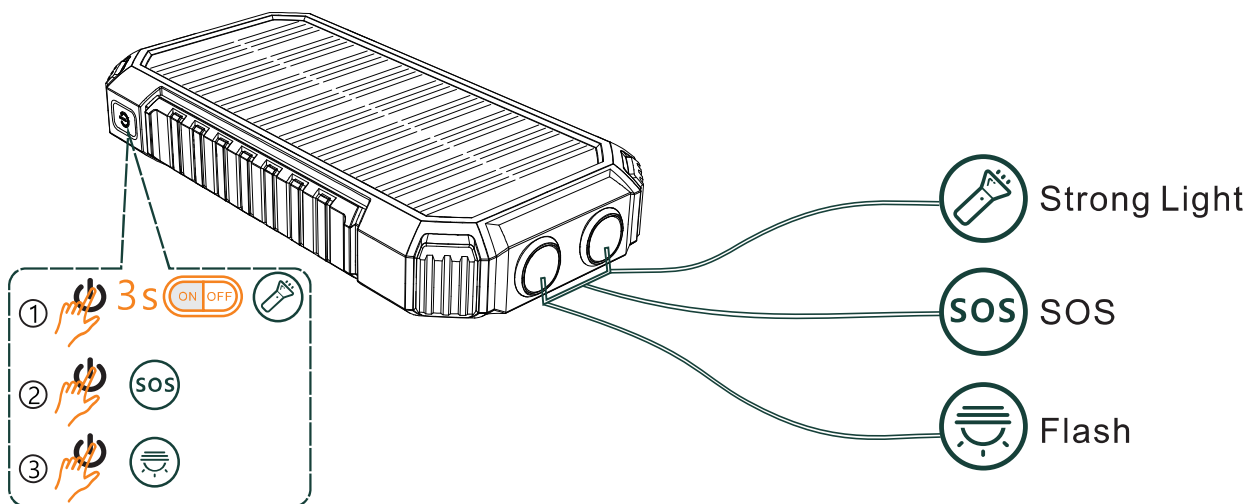

Check Remaining Power.

DE: Überprüfen Sie Ihren Akku.

FR: Vérifiez la puissance restante.

ES: Revisar la energía restante.

IT: Controlla la carica rimanente.

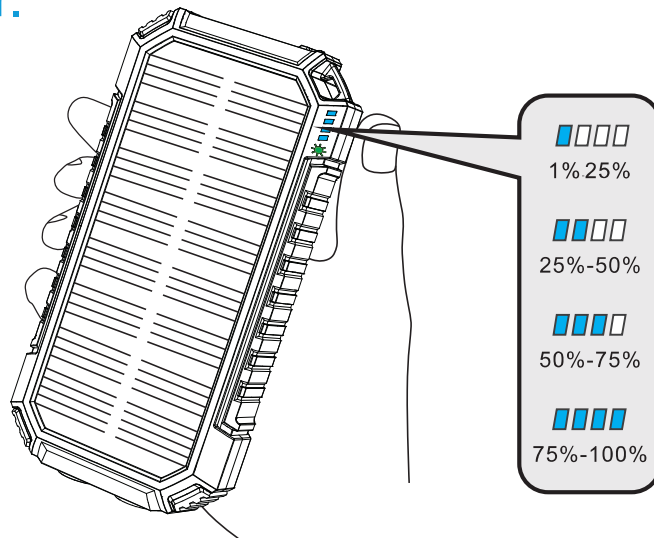

Charge Your Phone or Tablet.

DE: Laden Sie Ihr Handy oder Tablet.

FR: Rechargez votre téléphone ou votre tablette.

ES: Cargar tu teléfono o tableta.

IT: Carica il tuo telefono o tablet.

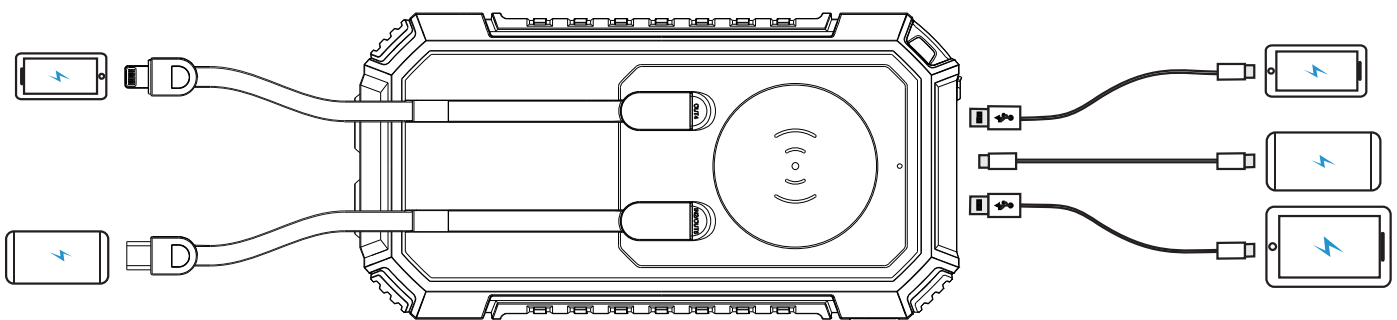

Three Recharging Methods

DE: Drei Lademethoden | **FR:** Trois méthodes de recharges

ES: Tres métodos de recarga | **IT:** Tre metodi di ricarica

1. By USB Cable (Use PD/QC adapter to achieve faster charging).

DE: Per USB-Kabel (Verwenden Sie den PD/QC-Adapter, um noch chnseller zu laden.).

FR: Par câble USB (Utiliser l'adaptateur PD/QC pour avoir une charge rapide.).

ES: Mediante el cable USB (Usa adaptador PD/QC para lograr una carga más rápida.).

IT: Con cavo USB (Utilizzando l'adattatore PD/QC per ottenere la ricarica veloce.).

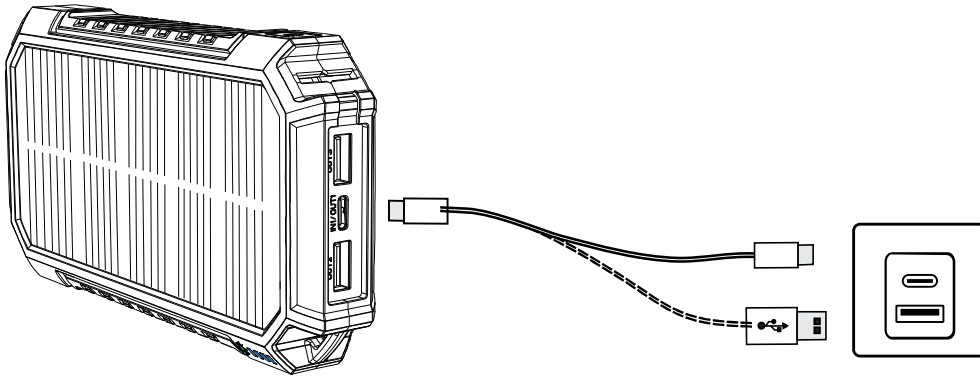

2. By Built-in USB-C Cable

DE: Durch integriertes USB-C-Kabel | **FR:** Via le câble USB - C intégré

ES: Por cable USB-C incorporado | **IT:** Tramite cavo USB-C integrato

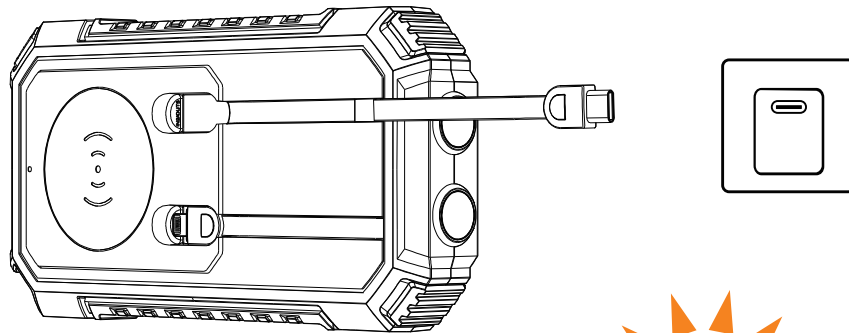

3. By Sunlight

DE: Per Sonnenlicht

FR: Par la lumière du Soleil

ES: Mediante la luz del sol

IT: Alla luce del sole

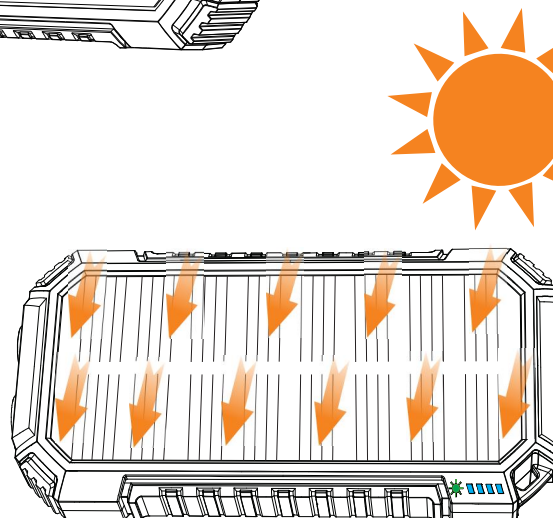

How to Charge Your Phone by Wireless Charging Function?

P.S. Your phone must be equipped with Qi charging function.

DE: Wie lade ich mein Handy mit der Drahtlos-Funktion?

(Achtung: Ihr Handy muss mit Qi Funktion ausgestattet sein.)

FR: Comment recharger votre téléphone grâce à la fonction de recharge sans fil ?

(N.B: Votre téléphone doit être équipé de la fonction de recharge Qi.)

ES: ¿Cómo cargar su teléfono mediante la función de carga inalámbrica?

(P.D . su teléfono debe estar equipado con la función de carga Qi.)

IT: Come caricare il telefono tramite la funzione di ricarica wireless?

(P.S. Il telefono deve essere dotato della funzione di ricarica Qi.)

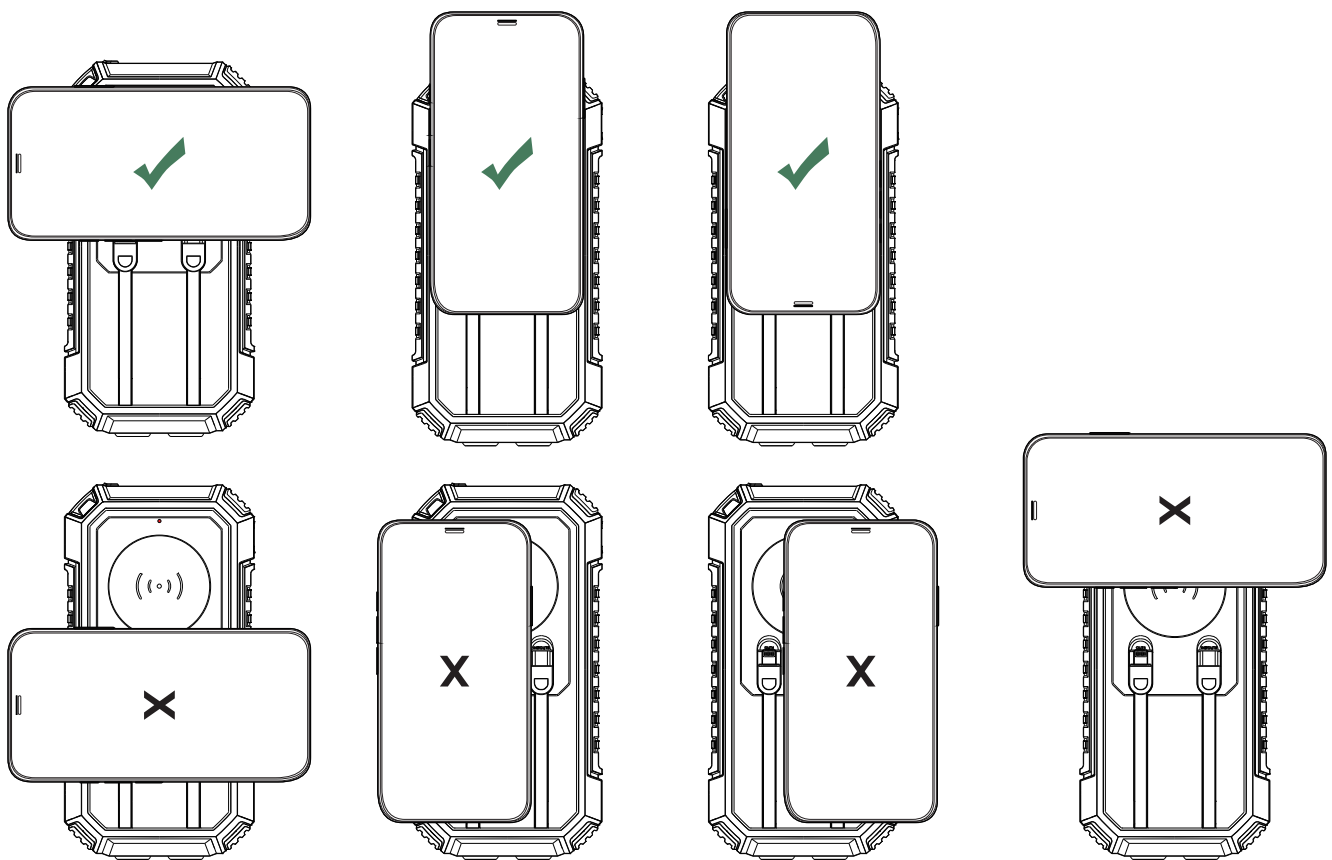

EN:

1. Press the Power Button to activate the wireless charging function, then the wireless charging indicator will light up. Place your phone on the wireless charging panel, making sure that the center of the phone is aligned with the center of the wireless charging panel. In this way, your phone will be charged within 2s, if not, please adjust the location of the phone.
2. The distance between the phone and the wireless charging panel must be less than 3mm, if the phone case is too thick, it will affect the wireless charging function.
3. No metal objects, such as metal phone case, coins, metal sheet etc., can be placed between the device to be charged and the wireless charging panel.

DE:

1. Drücken Sie den Power Knopf, um das drahtlose Ladegerät zu aktivieren, dann wird die blaue Ladelampe aufleuchten. Platzieren Sie Ihr Handy auf dem drahtlosen Ladefeld und versichern Sie sich, dass das Handy mittig im Zentrum des Felds liegt. So wird Ihr Handy nach 2 Sekunden aufladen. Falls nicht, justieren Sie die Position des Handys.
2. Die Entfernung zwischen Handy und drahtlosem Ladefeld muss weniger als 3mm betragen. Sollte die Hülle des Handys zu dick sein wird sich dies auf die Ladefunktion auswirken.
3. Keine metallischen Objekte, wie zum Beispiel metallene Handyhüllen, Münzen, sonstige Metallstücke etc. dürfen zwischen dem zu ladenden Gerät und dem drahtlosen Ladefeld platziert werden.

FR:

1. Appuyez sur le bouton d'alimentation pour activer la fonction de chargement sans fil, puis le témoin de chargement sans fil s'allume. Placez votre téléphone sur le panneau de chargement sans fil, en vous assurant que le centre du téléphone est aligné avec le centre du panneau de chargement sans fil. De cette façon, votre téléphone sera chargé dans les 2s, si ce n'est pas le cas, veuillez ajuster l'emplacement du téléphone.
2. La distance entre le téléphone et le panneau de chargement sans fil doit être inférieure à 3 mm, si le boîtier du téléphone est trop épais, cela affectera la fonction de chargement sans fil.
3. Aucun objet métallique, tel qu'un étui de téléphone en métal, des pièces de monnaie, une feuille de métal, etc. ne peut être placé entre l'appareil à charger et le panneau de chargement sans fil.

ES:

1. Presione el botón de encendido para activar la función de carga inalámbrica, luego se encenderá el indicador de carga inalámbrica. Coloque su teléfono en el panel de carga inalámbrico, asegurándose de que el centro del teléfono esté alineado con el centro del panel de carga inalámbrico. De esta manera, su teléfono se cargará en 2 segundos, si no, ajuste la ubicación del teléfono.
2. La distancia entre el teléfono y el panel de carga inalámbrica debe ser inferior a 3 mm, si la carcasa del teléfono es demasiado gruesa, afectará la función de carga inalámbrica.
3. No se pueden colocar objetos metálicos, como estuches metálicos para teléfonos, monedas, láminas de metal, etc., entre el dispositivo que se va a cargar y el panel de carga inalámbrico.

IT:

1. Premere il pulsante di accensione per attivare la funzione di ricarica wireless, posizionare il telefono sul pannello di ricarica wireless, accertandosi che il centro del telefono sia allineato con il centro del pannello di ricarica wireless. In questo modo, il telefono verrà addebitato entro 2 secondi, in caso contrario, regolare la posizione del telefono.
2. La distanza tra il telefono e il pannello di ricarica wireless deve essere inferiore a 3 mm, se la custodia del telefono è troppo spessa, ciò influirà sulla funzione di ricarica wireless.
3. Nessun oggetto metallico, come custodia del telefono in metallo, monete, lamiera ecc., Può essere posizionato tra il dispositivo da caricare e il pannello di ricarica wireless.

When your solar charger is fully recharged, the indicator lights will stay on and no flashing.

DE: Wenn Ihre Power Bank vollständig aufgeladen ist, leuchtet die Anzeige weiter.

FR: Lorsque votre Power Bank est totalement rechargé, l'indicateur de charge reste activé.

ES: Cuando tu banco de energía esté completamente lleno, el indicador permanecerá encendido.

IT: Quando la power bank sarà completamente ricaricata, l'indicatore rimarrà acceso.

Please fully charge the solar charger before first use.

DE: Bitte laden Sie die Power Bank vollständig auf, bevor Sie sie zum ersten Mal verwenden.

FR: Veuillez recharger complètement le Power Bank avant de l'utiliser pour la première fois.

ES: Por favor cargue completamente el banco de energía antes de usarlo por primera vez.

IT: Si prega di caricare completamente la power bank prima di utilizzarla per la prima volta.

Attention

DE: Achtung | ES: Atención | IT: Attenzione



To preserve lifespan, recharge every 3 months.

DE: Laden Sie das Gerät alle 3 Monate auf, um die Lebensdauer zu verlängern.

FR: Afin de préserver la durée de vie de votre Power Bank, il est recommandé de le recharger tous les 3 mois.

ES: Para preservar la vida útil recargue cada 3 meses.

IT: Per preservare la durata della batteria, ricaricate ogni 3 mesi.

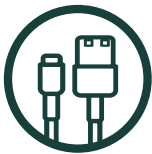

Use original or certified cables.

DE: Verwenden Sie original- oder zertifizierte Kabel.

FR: Utilisez uniquement des câbles originaux ou certifiés.

ES: Use los cables originales o certificados.

IT: Utilizzate cavi originali o certificati.



Don't expose to liquids.

DE: Darf keinen Flüssigkeiten ausgesetzt werden.

FR: Ne pas l'exposer aux liquides.

ES: No se exponga a los líquidos.

IT: Non esporre a liquidi.



Don't disassemble.

DE: Darf nicht auseinandergebaut werden.

FR: Ne pas le démonter.

ES: No desarma.

IT: Non smontare.



Avoid dropping/scratch.

DE: Vermeiden Sie Fallenlassen/Kratzer.

FR: Evitez de le faire tomber ou de le rayer.

ES: Evite dejarlo caer/rayarlo.

IT: Evita di far cadere/graffiare.



Avoid extreme temperatures.

DE: Vermeiden Sie extreme Temperaturen.

FR: Evitez les températures extrêmes.

ES: Evite temperaturas extremas.

IT: Evita temperature estreme.

FCC Compliance Statement

This device complies with Part 15 of the FCC Rules. Operation is subject to the following two conditions: (1) this device may not cause harmful interference, and (2) this device must accept any interference received, including interference that may cause undesired operation.

NOTE: This equipment has been tested and found to comply with the limits for a Class B digital device, pursuant to Part 15 of the FCC Rules. These limits are designed to provide reasonable protection against harmful interference in a residential installation. This equipment generates, uses and can radiate radio frequency energy and, if not installed and used in accordance with the instructions, may cause harmful interference to radio communications. However, there is no guarantee that interference will not occur in a particular installation. If this equipment does cause harmful interference to radio or television reception, which can be determined by turning the equipment off and on, the user is encouraged to try to correct the interference by one or more of the following measures:

- Reorient or relocate the receiving antenna.
- Increase the separation between the equipment and receiver.
- Connect the equipment into an outlet on a circuit different from that to which the receiver is connected.
- Consult the dealer or an experienced radio/TV technician for help.

CAUTION: Changes or modifications not expressly approved by the party responsible for compliance could void the user's authority to operate the product.