

Lisowod

USER MANUAL

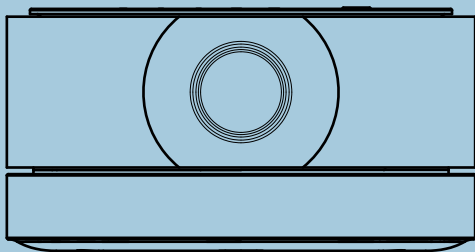

An1 VIDEO PROJECTOR

Where Quality Meets Innovation

<http://www.ultraprojection.com>

LP

Dear customer,

Welcome to our projector's official website!

<http://www.ultraprojection.com>

We are a professional projector manufacturer committed to providing customers with high-quality projection experiences.

By logging into our official website, you can **activate your three-year warranty service online**. If you need to replace parts, our official website also provides **free** options for you to choose from.

You can find more information on our official website, including but not limited to verifying the authenticity of your purchased projector, contacting us online to solve your after-sales problems, and getting electronic manuals and various instructional videos for projectors.

When we launch new products, we will first look for volunteers on our official website to try our latest research and development products. Your feedback is our greatest motivation for continuous improvement.

CONTENTS

CONTACT US	001
TROUBLE SHOOTING	002
PACKING LIST	006
FUNCTION OVERVIEW	007
REMOTE CONTROL	010
CONNECTION OVERVIEW	011
QUICK START	014
Miracast and DLNA	016
-PC Miracast	017
-Android Miracast	020
-IOS Miracast	021
-DLNA Miracast	021
INPUT SOURCE	022
-HDMI Connection	022
MULTIMEDIA	023
-USB Connection	023
SETTING	023
-Picture Setting	023
-Brightness Mode	024
-System Setting	024
-Other Setting	025
-Warranty Card	026
BLUETOOTH CONNECTION	026
INSTALLATION	029
-Projection Distance and Size	029
-Installation Method	030
Mount Ceiling Method	031
PROJECTOR SPECIFICATIONS	032

Please contact Lisowod official to verify the authenticity of your Lisowod projector, here are the official email addresses:

 **US: Support_us@Lisowod.com**

 **JP: Support_jp@Lisowod.com**

WE ARE

constantly optimizing and upgrading our products, the pictures and descriptions in the manual are for reference only may differ from the actual product, please refer to the actual product. You can get the latest version through online upgrade. Thank you for your understanding.

Our High qualified and responsible customer service team is waiting to hear from you and answer any of your questions **24/7**.

We are happy to receive your message about the problems you met so that we can help you to get out of the trouble. We are even happier to hear your praise about our wonderful projector and to see the happy moments our projector have brought to your life!

The fastest and most efficient way to contact us?

Method 1- Via email:

🇺🇸 **US: Support_us@Lisowod.com**

● **JP: Support_jp@Lisowod.com**

Method 2:

Your Orders > The order has a problem > Choose a topic from list displayed > Select Contact seller

Please come. Please~~~



CONTACT US

Thank you very much for supporting Lisowod! Hope our products and services bring you a pleasant journey of audio-visual enjoyment.

Lisowod promises a 3-Year Warranty and Lifetime Technical Support, please

do not worry when encountering any problems. **Any buyer with any questions who comes to contact us will have our promise to get a satisfactory solution + an Extra 6-Month Warranty to thanks for your support!**

By the way, we are racking our brains to develop a new projector. If you have any ideas about projector, such as user experience, parameters, features, colors and appearance, we warmly invite you to tell us in detail. We value all voices, and you won't imagine how much we look forward to your ideas. **Once your idea is adopted, as a thank you, I will apply to send one to you for FREE as the first tester when the new product is developed.**

Looking forward to your messages!

Lisowod Support Team

Scan QR code below, start chatting with us!!!



Scan this code, learn how to operate the projector visually on YouTube!!!



US:Support_us@Lisowod.com



JP:Support_jp@Lisowod.com



YouTube: Search "Lisowod" on YouTube



TROUBLE SHOOTING

Our high-qualified customer services team is waiting to hear from you and answer any of your questions 24 hours a day and 7 days a week. We are happy to receive your message about the problems you met so that we can help you to get out of the trouble. You can contact us through email.

 **US: Support_us@Lisowod.com**

 **JP: Support_jp@Lisowod.com**

Q: Where can I find the instructional videos on how to set up the projector?

A: We have prepared detailed operation videos on YouTube, which contains almost every step of operating the projector, like WiFi connection, wired connection and so on. Just search "Lisowod" on YouTube and you will find them

Q: I can't play Netflix video on the projector, why?

A: There are quite a few video platforms like Netflix, Disney+, and Hulu are under HDCP copyright protection, and thus do not support being displayed on a projector, this is the same situation for all projectors. You would need a Roku/TV stick to enjoy these video platforms.

Q: The projector is not that bright when using it, how should I do?

A: ① Use rechargeable mode as much as possible: In order to obtain the best brightness and projection effect, it is recommended that users use the rechargeable mode as much as possible when using the projector. Using the battery mode may cause a decrease in brightness and a deterioration in the projection effect.

② Ensure the battery is fully charged: Before using the projector, please ensure that the battery is fully charged. Using an uncharged battery may affect the brightness and projection effect.

③ Avoid over-discharging: Please avoid over-discharging the battery. When the battery level is below a certain preset value, the projector may automatically shut down to protect the battery. Over-discharging the battery may damage the battery and affect its life and performance.

Q: I adjust the focus with the remote control but the picture is still blurry, what should do?

A: ① The recommended projection distance is 4ft-9.5ft(1.2m-3m). ② Please adjust your projection distance accordingly and adjust the focus until you reach the best image quality.

Q: I connect the projector and my phone with same WiFi, but I can't find the projector's name when I want to do screen mirroring.

A: ① Please make sure your WiFi is in good running speed.

② You can try to reset WiFi or restart the projector, or restore factory default. You can find the operation videos on our "Lisowod" channel on YouTube.

③ If you tried the above ways and still can't solve the problem, please send emails to our support team along with your order number. We will find solutions for you.

Q: I can't connect the projector with my sound bar. How should I fix this problem?

① Please make sure you followed our operation steps correctly. And make sure your sound bar has not connected to any other Bluetooth devices.

② Since there are so many different kinds of Bluetooth speakers on the market, this is a challenge all the projectors are facing with and working to improve. Please email us for further instructions.

Q: I received the projector but it has no remote control. Could you send it to me?

A: If the product you receive is missing any accessories, please let us know what accessory you miss. We will send them to you as soon as possible.

Q: The projector worked for ten minutes and suddenly shut down. What should I do?

A: We promise that our projector has been carefully checked before shipping. However, the long time and distance shipping may cause damage to the projector. If your projector can not work, please contact us and we will offer you a satisfactory solution.

Q: I contacted the customer service team as suggested, but has not received any reply. Why?

A: We promise that we will reply to all the emails within 24 hours. If you haven't received any reply from us more than one day, then maybe our email has been blocked or has gone to the spam email box. Please send us email again or contact us by Instagram (see QR code on Page 01). Thank you for your understanding.

Q: There appear big brown spots in the projector's screen after I use it for about 3 months. Can I have this problem solved?

A: ① This phenomenon is often caused by overheating of the projector. Please make sure the projector's ventilation inlet and outlet are uncovered to ensure that the projector can dissipate heat properly.

② Please turn off the projector, wait for a few hours until it totally cooled off. And then restart the projector.

③ If you can not solve your problem, please feel free to contact us. Our projector offers three-year warranty. We will be responsible for any quality problem of it.

Tips: To prolong the life of the projector, we recommend you to clean or exchange the dustproof net every two months. If you need the dustproof nets, please email us, we will send 10 Pieces of Dust-Proof Net for you for free so that you could replace it regularly.

 **US: Support_us@Lisowod.com**

 **JP: Support_jp@Lisowod.com**

Activate 3-Year Warranty

Dear customer,

Thank you for choosing Jimveo. We are here to invite you to activate your 3-Year warranty.

Please send **[order number + An1 + activate 3 years warranty]** to us! BTW, we have prepared some warm tips and surprises for you.

Extra Surprise - Free Gift

To improve your user experience, we have prepared 4 kinds of free gifts for you to choose from. If you need any one of them, please email us with **[Order Number + Projector Model + Gift You Want]** via **Support_us@Lisowod.com** to get more info.

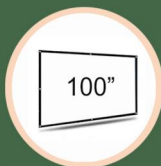

Option 1: 100" screen

Option 2: \$20 Gift Card

Option 3: Projector Ceiling Mount

Option 4: 1-year Extra Warranty

 Support_us@Lisowod.com

 Support_jp@Lisowod.com





Join Jimveo VIP Club What will you get?

VIP

1. **Free test** when our new upgraded projector or other product is available.
2. If you like our projector, please recommend it to your friends. You can get a **\$10 gift card** for each order and your friends can get a **5% discount**.
3. An extra **\$30 Gift Card** on your birthday month.

Tips: To prolong the life of the projector, we recommend you to clean or exchange the dustproof net every two months. If you need the dustproof nets, please email us, we will send **10 Pieces of Dust-Proof Net** for you for free so that you could replace it regularly.

Has your Jimveo left you unsatisfied?

Do not hesitate to tell us! Your personal Jimveo expert will reply to you and you will definitely get a satisfactory solution. Our team is ready and waiting to help should you have any questions!

Best regards,
Jimveo Customer Team

 Support_us@Lisowod.com

 Support_jp@Lisowod.com



PACKING LIST

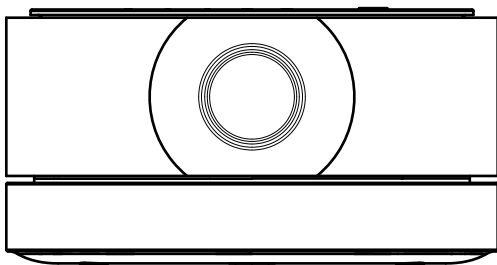

An1



Remote

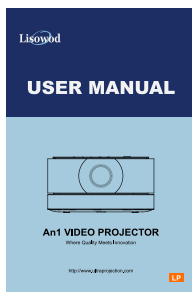

User Manual

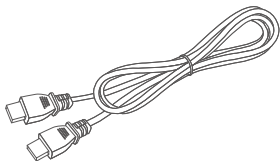

HD Cable



Power Cable

FUNCTION OVERVIEW

Top View



Control Panel

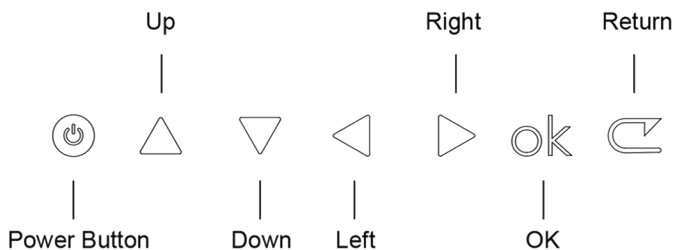

Side View

A. Left side

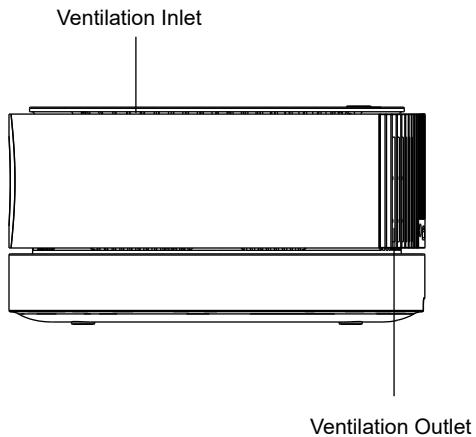

B. Right side

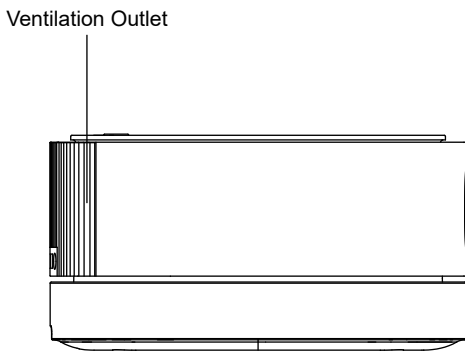

Rear View

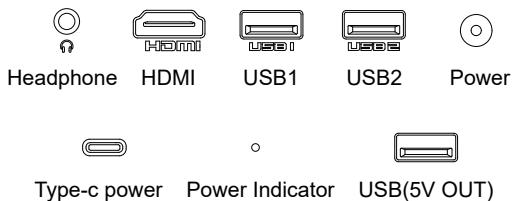
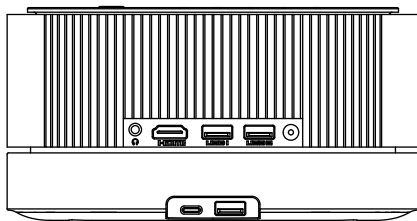

Bottom View

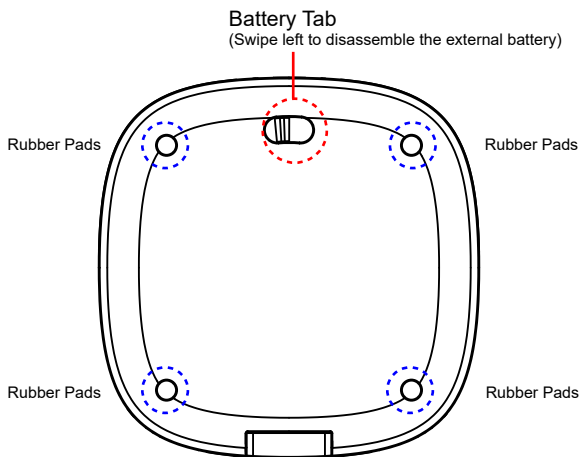

REMOTE CONTROL

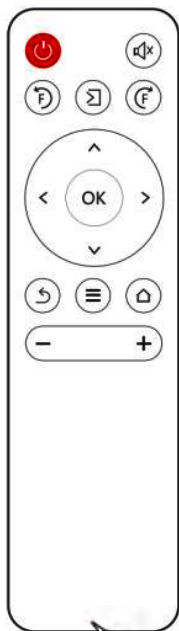
Power button:

Turn on/off

Mute button:

Mute

Focus button:

Adjust focal distance

Signal source button:

Choose to enter the Application Center, HDMI

Return button:

return to last step

Menu button:

enter the setting page

Home button:

short press and return to the homepage

Direction Buttons:

- Up ● Down
- Left ● Right
- OK

Volume button:

Volume-, Volume+

If the remote control is damaged
 or lost, please contact the email
 address in the upper right corner.

Installation of the remote control

1. Install 2 pieces of AAA batteries into the remote before using it. Do not combine new batteries with old ones in a remote controller, which can cause operation failure due to insufficient power supply.
2. When using the remote controller, please make sure that the signal transmitter of the remote controller aims at the infrared signal receiver of the projector.

CONNECTION OVERVIEW

The An1 projector consists of two parts: the projector body and the external battery base. The battery base can be used alone as a battery. It can also be combined with the projector body to make it a battery-powered projector.

• Combined use

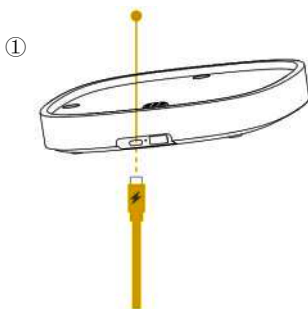

① Use the Type-C port to charge the battery. When the battery is being charged, the indicator light stays on in red. When the battery is fully charged, the indicator light turns off.

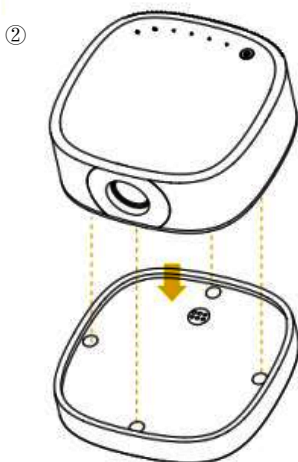

② The battery can be combined with the projector body. Place the projector body on the battery base and press gently. Make sure the body is tightly linked to the base from all sides.

③



Combined charging

③When combined together, the battery can power the projector so that you can use the projector without a power cable. **Please note that the brightness of the projector would decrease at this mode to ensure the projector can work for a longer time.** (You can still use the power cable under the combined mode. The brightness would go back to normal range.)

Notes:

1.It is estimated to take 3.5 hours to charge the battery base alone, and 11.5 hours to charge the battery under combined mode when the projector is working.

2.When the indicator light is flashing, it might be the charging time is too long/ fault alarm/ battery abnormality, etc. You can re-plug the power supply.

• Take it apart and use

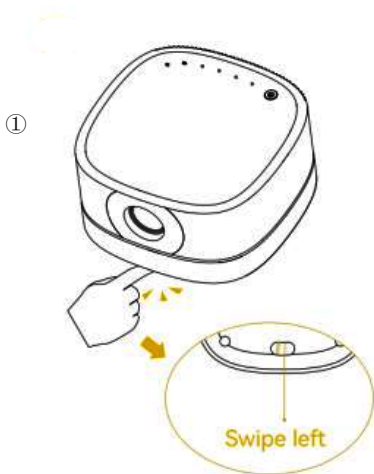

① Swipe left the battery tab at the bottom of the base to disassemble the external battery.

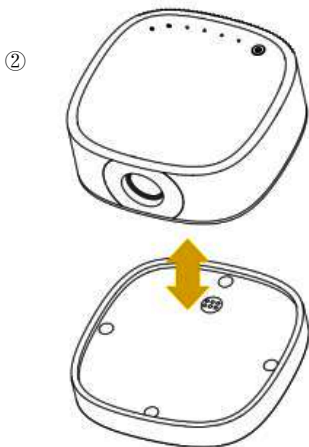

② The projector body and the battery base can be taken apart and be used separately.

③ Can be externally charged to a variety of devices

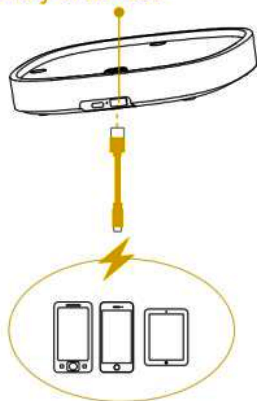

③ The battery can charge a variety of devices via the USB port.

QUICK START

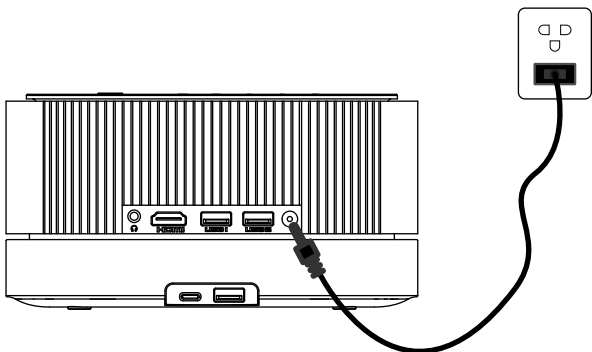

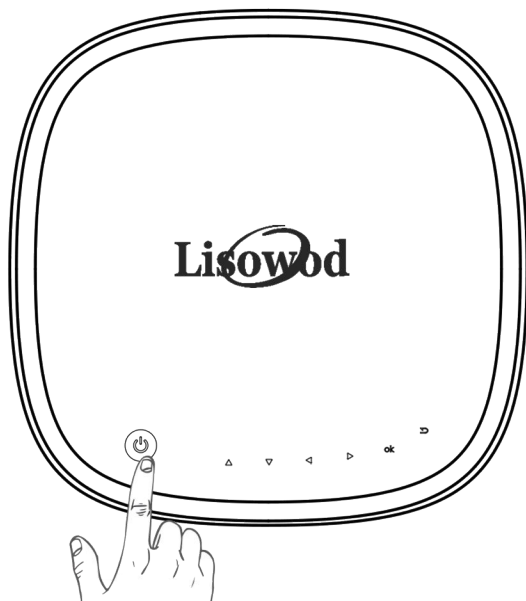

1. Plug the power cord into an outlet.

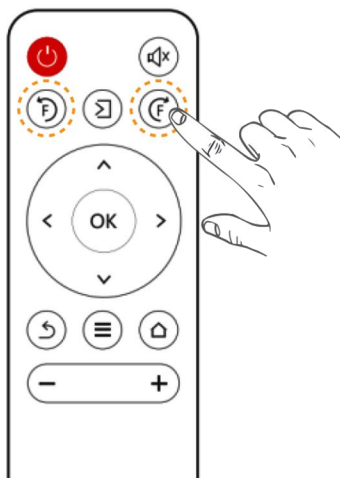

2. Press the power button to turn on the projector.



3. Press the “” “” button on the remote to get the best image performance.



4. Press the power button twice to turn off the projector.

Miracast and DLNA

Warming Tips:

- ① The fluency of screen mirroring with wireless connection will be affected by the network environment. A bandwidth of 100Mbit or more is recommended when using screen mirroring.
- ② Make sure your mobile device is close to the projector when using wireless connection. A distance within 1 meter is recommended.
- ③ Some mobile devices may not support screen mirroring due to the compatibility.
- ④ Any questions, please feel free to email **Lisowod** via

Support_us@lisowod.com

Support_jp@lisowod.com

• PC Miracast

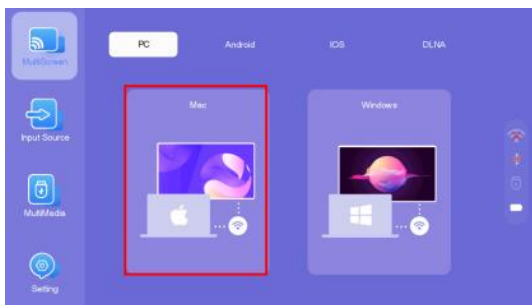

For MacBook:

1. Connect your laptop with Router's wifi
2. Click the apple logo on the top left, choose [System Preference]
3. Click [Sharing] on the appearing page
4. Check the box [Screen Sharing]. Close the page.
5. Click on the AirPlay Display on the top right, choose [AN1-XXXX] to connect

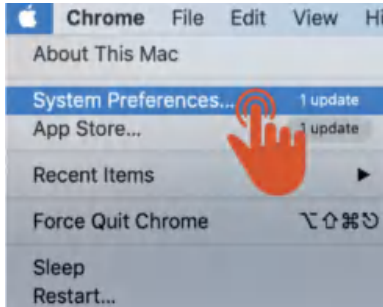

The casting identification varies among different software versions.



For Windows Laptop:

1. Connect your laptop with Router's wifi
2. Click [Win+P] or [Win+K] on the PC to enter the projection settings
3. Choose the [Duplicate] Mode
4. Click [Connect to a wireless display]
5. Among the available devices, choose [AN1-XXXX] to connect

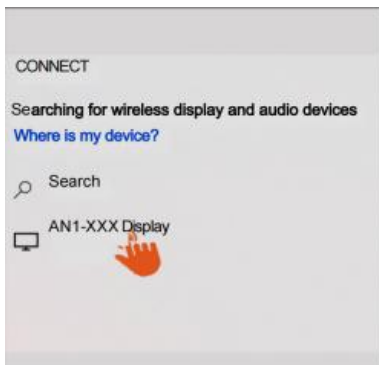
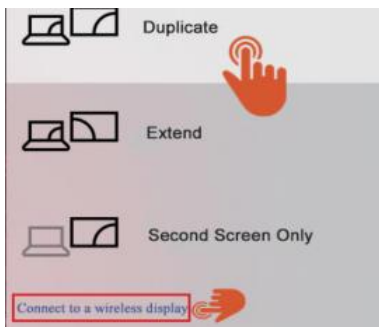

• Android Miracast

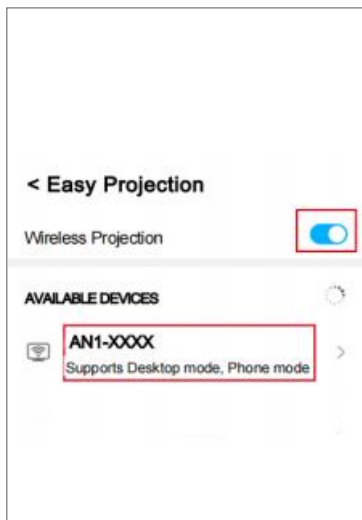
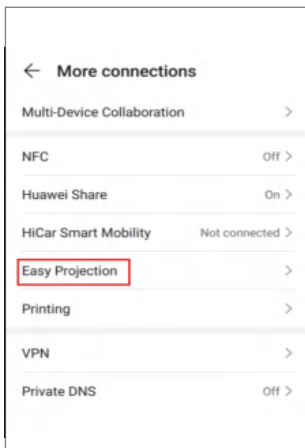
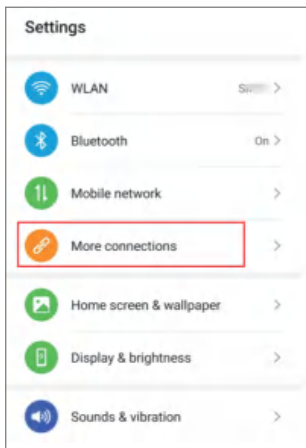

• IOS Miracast

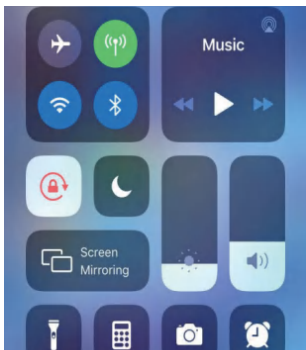

• DLNA

1. Connect your mobile/Pad device and projector with the same Router's wifi
2. Open your video player app
3. Click the TV icon and select the projection name
4. Among the available devices, choose [AN1-XXXX] to connect



INPUT SOURCE

In the home page, press the “” on the remote to open the HDMI connection page.

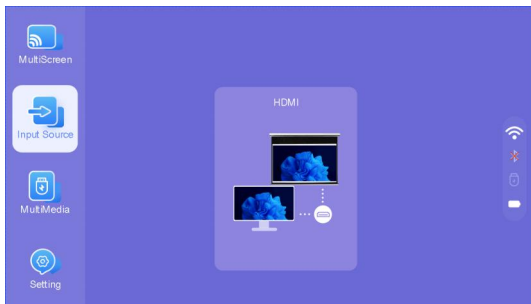

HDMI Connection

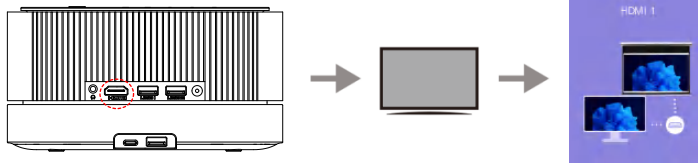

1. Connect one end of the HDMI cable to the HDMI output port on the device you want to connect, and insert the other end into the HDMI input port on the projector.
2. Clicking HDMI on the homepage screen, you can play video through HDMI.

MULTIMEDIA

USB Connection

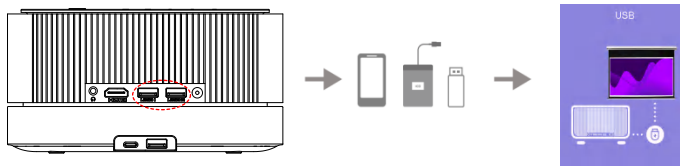

1. Insert the USB memory into the projector. If the connection is successful, the USB indicator light on the top right of the homepage will light up.
2. By selecting "Text," "Movie," "Music," or "Photo" on the homepage screen, you can play files from the USB.

Speaker Connection

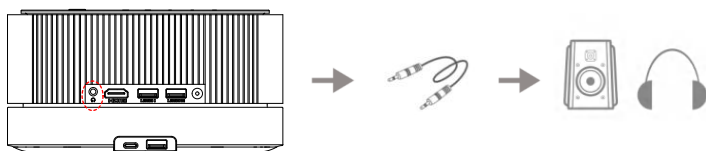

1. Connect the speakers/headphones to the projector via a 3.5 mm audio cable.

SETTINGS

In the home page, press the “” on the remote to open the setting page.

• Picture Setting

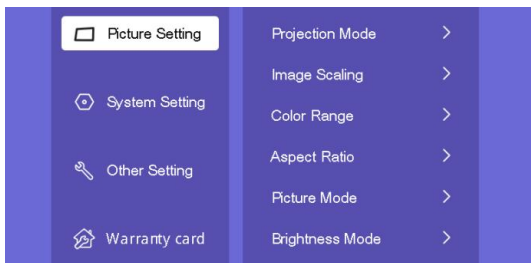

Item	Option	Function
Projection Mode	Normal Front/ Normal Back/ Invert Front/ Invert Back	Set projection directions
Image Scaling	100% to 75%	Zoom the picture from 100% to 75%
Color Range	Auto/ 16-235/ 0-255	Available when connected to PC via HDMI
Aspect Ratio	Auto/ 4:3/ 16:9	Set projection aspect ratio
Picture Mode	User/Standard/ Dynamic/ Mild	Set picture mode
Brightness Mode	Normal Mode/Green Mode/ Custom Mode(1-10)	Adjust the projector brightness

• Brightness Mode

Normal Mode: Highest Brightness. Default mode of the projector. Equal to the custome mode 10 brightness.

Green Mode: Lowest Brightness. Equal to the customer mode 0 brightness.

Custom Mode: Adjust the projector brightness from 0-10

• System Setting

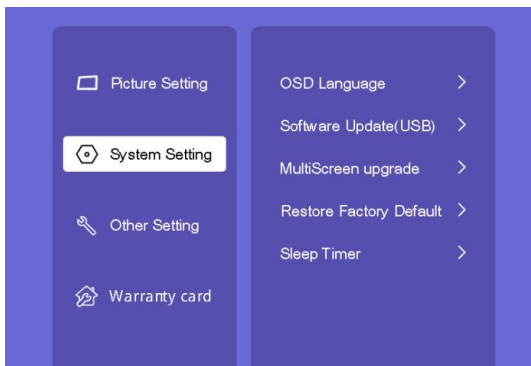

Item	Option	Function
OSD Language	English/ Spanish/ Chinese/ Japan etc.	Set language. 26 languages for you to choose from
Software Update(USB)	/	Update software via USB
MultiScreen Upgrade	/	Update the MultiScreen System
Restore Factory Default	/	Restore the projector to factory default
Sleep Timer	Off/10 Min/30 Min/ 60 Min/ 90 Min/ custom	Set designated time to turn off the projector

• Other Setting

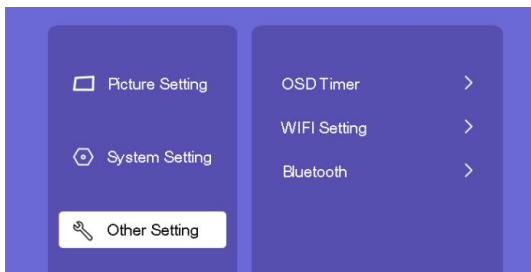

Item	Option	Function
OSD Timer	5 Sec/10 Sec/ 15 Sec/ Off	Set OSD time
WIFI Setting	/	Turn on/off wifi, Search and connect to wifi.
Bluetooth	/	Turn on/off Bluetooth, Search and connect to bluetooth device

• Warranty card

Activate Your 3-Year Warranty

Please email us to Activate your warranty and ensure your benefits below!

When Key-Win turn

- 24/7 customer service, reply to all messages within 24 hours.
- Promise to get your problem resolved and an Extra 6-month warranty when you contact us.
- Upgrade software if a new one is available.
- Detailed and Instructive operation videos.

3年間の保証期間も有効にしましょう！

メールにてご連絡いただければ、保証も有効にするほか、下記の特典も受け取れます。

お客様が望む

- 24時間年中無休で安心なスタッフより迅速に対応いたします。
- ご連絡いただければ、最中かに問題を解決するほか、余分 12 か月の保証を提供いたします。
- New versionも発売する場合、upgrade softwareも提供いたします。
- 詳しい操作ビデオを提供いたします。







Support_us@Lisowod.com
Support@Lisowod.com

Contact manufacturer to activate your 3-year warranty

BLUETOOTH CONNECTION

Bluetooth Mode: Connect to external speakers

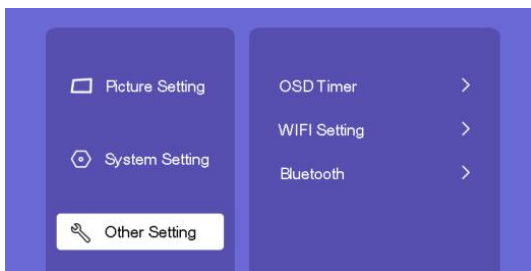
Step 1: On the home page, go to [Setting]---[Other Setting]---[Bluetooth]. Press [OK] button to enter.



Step 2: On the Bluetooth page, press right button to turn Bluetooth on. Click [Search BT] to search for available devices to connect. When it shows [Connected], the speaker was connected to the projector successfully.

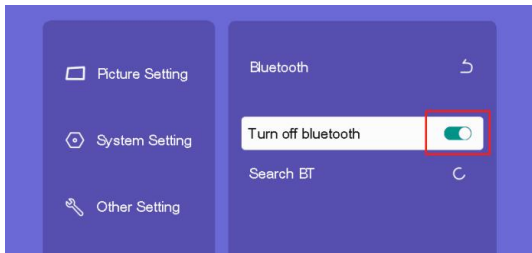

Notes: If it shows [Saved] or [Paired], it has not connected successfully. In this case, please contact customer service for help.

 Support_us@lisowod.com

 Support_jp@lisowod.com

Speaker Mode: Projector works as a speaker and play music from your mobile devices.

Step 1: Long press the Power button for 3 seconds. Choose the "Speaker Mode" on the right.

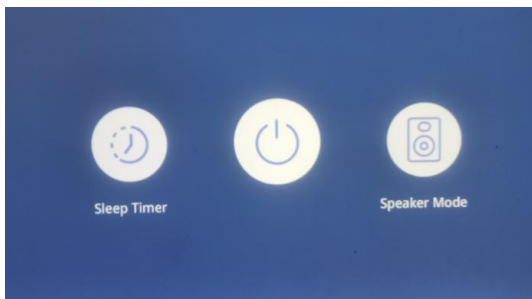

Step 2: Stay at the Bluetooth speaker page. Open the Bluetooth function on your mobile phone, search for available devices, choose "BT6556PJ" to connect.

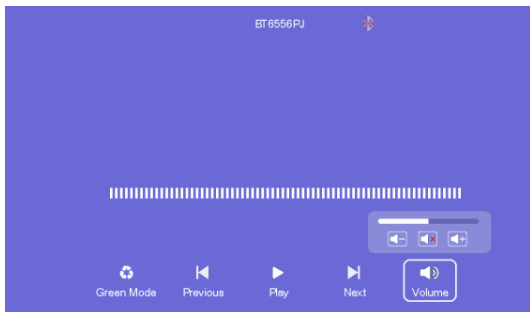

Step 3: Open the music apps on your phone. Now the projector can work as a speaker and plays the musics.

Notes: When the projector work as a speaker, you can choose the "Green Mode" on bottom left, under which the projector will turn off the light to save power.

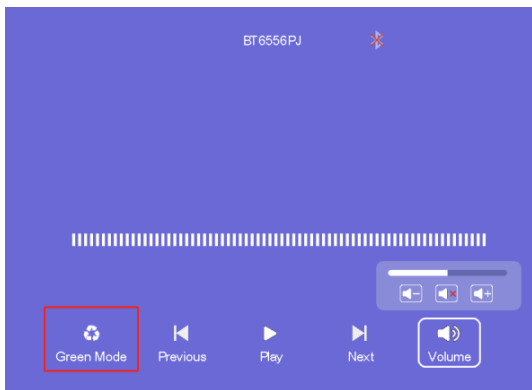

Installation

1. Projection Distance and Size

Please follow the data in chart below, to adjust the image size and the distance.

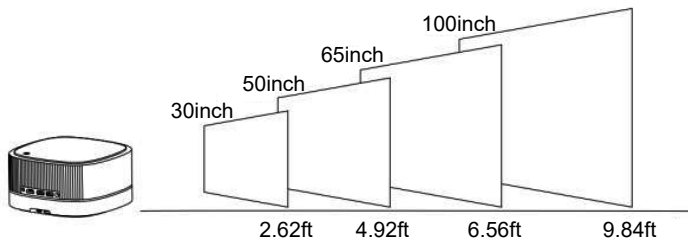

AN1 Projection Size and Distance

Projection Size (Inch)	30	50	65	100	160	200
Projection Distance(ft)	2.62	4.92	6.56	9.84	16.4	19.69

Please note that the best image quality would be achieved with a projection distance of 6.5-9.8ft. A larger screen size would affect the image quality in a certain degree.

2.Installation Method

The projector support front and rear projection, it can be table mounted and ceiling mounted. In the home page, go to [Setting]---[PictureSetting]---[Projection Mode]. Choose your desired projection mode. There are four modes here:Front Table/Rear Table/ Front Ceiling/Rear Ceiling.

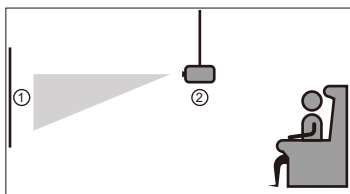
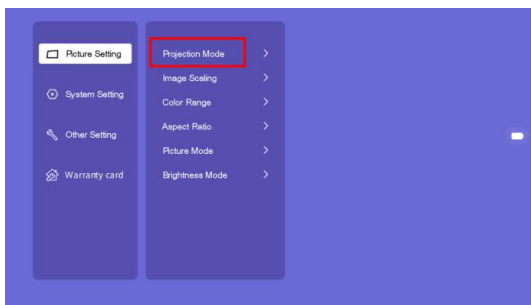

Front/ceiling

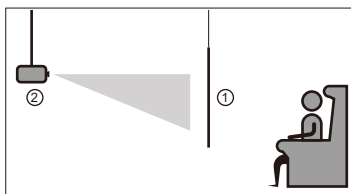

Rear/ceiling

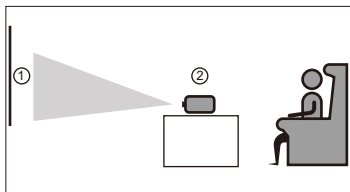

Front

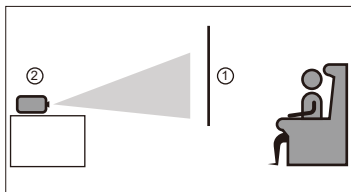

Rear

Please keep the projector at a height where its lens is axial symmetry to the screen.

*Any buyer with any questions who comes to contact us will have our promise to get a satisfactory solution + an Extra 6 Month Warranty to thanks for your support!

 Support_us@lisowod.com

 Support_jp@lisowod.com

Mount Ceiling Method

Please note that our projector only support the one-hole ceiling mount

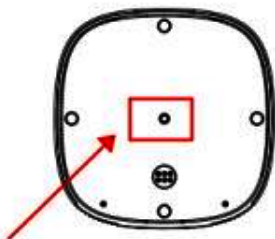

Ceiling Mount Hole

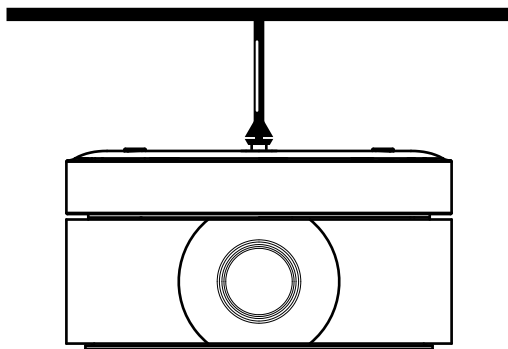

PROJECTOR SPECIFICATIONS

Imaging technology	TFT LCD
Power input of battery base	16V/1.3A
Native resolution	1920*1080P
Input	USB*2/HDMI*1
Light source	LED
Output	Earphone/USB(5V OUT)
Focus mode	Electronic focus
Output interface of battery base	USB(5V OUT)
Projection distance	2.62ft-19.69ft
Colour	White/Grey
Screen size	30-200 inches
Unit size	180*180*94mm
Aspect ratio	16:9 and 4:3 and Auto-fit
Net Weight	1.39KG
Power input	19V/3.42A
Throw Ratio	1.4:1

Please note:

1. The best image quality would be achieved with a projection distance of 6.5-8.5ft. A larger screen size would affect the image quality in a certain degree. 2. The image size depends on the distance between projector and screen, there may be 3% deviation among above listed data. Different settings cause various distances.

FCC STATEMENT :

This device complies with Part 15 of the FCC Rules. Operation is subject to the following two conditions:

- (1) This device may not cause harmful interference, and
- (2) This device must accept any interference received, including interference that may cause undesired operation.

Warning: Changes or modifications not expressly approved by the party responsible for compliance could void the user's authority to operate the equipment.

NOTE: This equipment has been tested and found to comply with the limits for a Class B digital device, pursuant to Part 15 of the FCC Rules. These limits are designed to provide reasonable protection against harmful interference in a residential installation. This equipment generates uses and can radiate radio frequency energy and, if not installed and used in accordance with the instructions, may cause harmful interference to radio communications. However, there is no guarantee that interference will not occur in a particular installation. If this equipment does cause harmful interference to radio or television reception, which can be determined by turning the equipment off and on, the user is encouraged to try to correct the interference by one or more of the following measures: Reorient or relocate the receiving antenna. Increase the separation between the equipment and receiver. Connect the equipment into an outlet on a circuit different from that to which the receiver is connected.

Consult the dealer or an experienced radio/TV technician for help.

FCC Radiation Exposure Statement:

This equipment complies with FCC radiation exposure limits set forth for an uncontrolled environment. This equipment should be installed and operated with minimum distance 20cm between the radiator & your body.

Please read the notes carefully:

- To ensure stable power supply, please use national standard power cable and power cord with grounding;
- Please use the type of power supply indicated on the projector and the supplied power supply for power supply;
- Please do not disassemble the machine yourself, otherwise the company will not undertake warranty service;
- Do not look directly at the projector lens while the machine is working, it might cause damage to your eyes;
- To prevent clogging the projector vents, do not cover them with cloth, carpet or other materials;
- This projector does not have waterproof function, please keep it away from rain, moisture and other items containing liquid such as vase, cup, etc;
- To prevent electric shock, please keep the projector away from rain, water or moisture;
Cut off the power supply if do not use this projector for a long time;
- Use the original foam or other anti-shock material to protect projector if you need transport this projector;
- If you find the projector has problems, please contact with the supplier, do not repair by yourself;
- To extend the projector life span and protect your eyesight, we suggest you may have a break after 3-4 hours using.

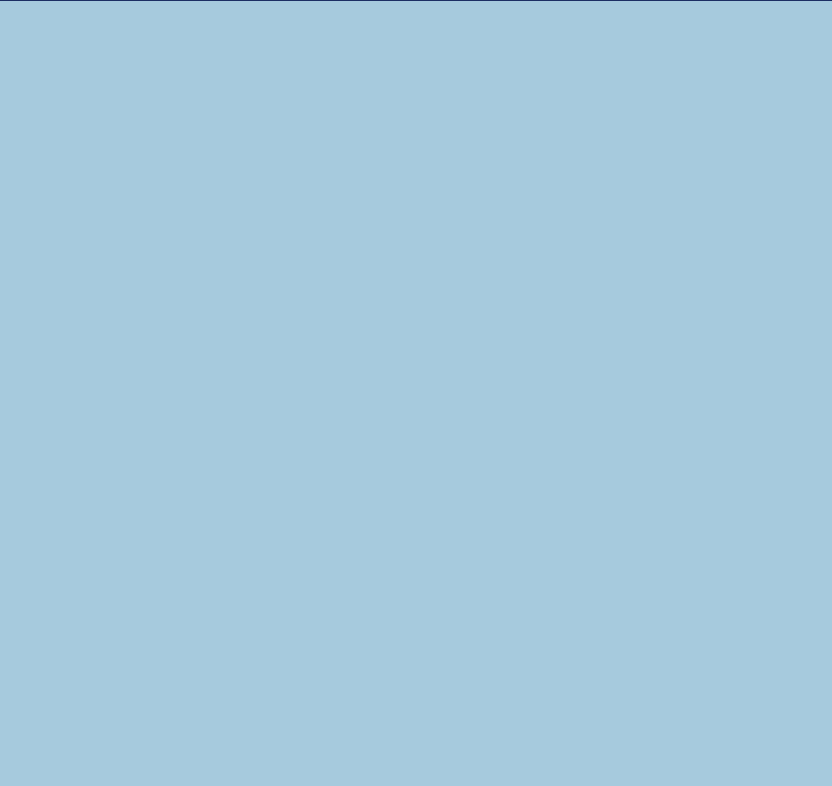

This equipment has been tested and found to comply with the limits for a Class B digital device, pursuant to part 15 of the FCC Rules. These limits are designed to provide reasonable protection against harmful interference in a residential installation. This equipment generates, uses and can radiate radio frequency energy and, if not installed and used in accordance with the instructions, may cause harmful interference to radio communications. However, there is no guarantee that interference will not occur in a particular installation. If this equipment does cause harmful interference to radio or television reception, which can be determined by turning the equipment off and on, the user is encouraged to try to correct the interference by one or more of the following measures:

- Reorient or relocate the receiving antenna.
- Increase the separation between the equipment and receiver.
- Connect the equipment into an outlet on a circuit different from that to which the receiver is connected.
- Consult the dealer or an experienced radio/TV technician for help.

Caution: Any changes or modifications to this device not explicitly approved by manufacturer could void your authority to operate this equipment.

This device complies with part 15 of the FCC Rules. Operation is subject to the following two conditions: (1) This device may not cause harmful interference, and (2) this device must accept any interference received, including interference that may cause undesired operation.

The device has been evaluated to meet general RF exposure requirement. This equipment complies with FCC radiation exposure limits set forth for an uncontrolled environment.

This equipment should be installed and operated with minimum distance 20cm between the radiator & your body.

IC warning statements:

-English Warning Statement:

RSS-GEN ISSUE 5, 8.4 User manual notice

This device contains licence-exempt transmitter(s)/receiver(s) that comply with Innovation, Science and Economic Development Canada's license exempt RSS(s). Operation is subject to the following two conditions:

- (1) This device may not cause interference.
- (2) This device must accept any interference, including interference that may cause undesired operation of the device.

The digital apparatus complies with Canadian CAN ICES-3 (B)/NMB-3(B).

-French Warning Statement:

RSS - Gen version 5, 8.4 avis du manuel de l'utilisateur

Cet appareil contient un émetteur / récepteur sans licence conforme au RSS sans licence d'innovation, science et développement économique Canada. L'opération doit satisfaire aux deux conditions suivantes:

Cet équipement peut ne pas causer d'interférence.

L'équipement doit accepter toute interférence, y compris toute interférence qui pourrait entraîner un fonctionnement indésirable de l'équipement.

This equipment complies with IC radiation exposure limits set forth for an uncontrolled environment and meets RSS-102 of the IC radio frequency (RF) Exposure rules. This equipment has very low levels of RF energy that are deemed to comply without testing of specific absorption ratio (SAR).

Cet équipement est conforme aux limites d'exposition aux rayonnements énoncées pour un environnement non contrôlé et respecte les règles d'exposition aux fréquences radio électriques (RF) CNR-102 de l'IC. Cet équipement émet une énergie RF très faible qui est considérée conforme sans évaluation du débit d'absorption spécifique (DAS).

This equipment should be installed and operated with minimum distance 20cm between the radiator & your body.

Lors de l'installation et du fonctionnement de cet équipement, la distance minimale entre le radiateur et le corps doit être de 20 cm.