

**FCC/IC - TEST REPORT**

Report Number : **68.950.21.0337.01** Date of Issue: **2021-05-25**

Model : **B181**

FCC ID : **2AZEQ-B181**

IC : **27102-B181**

Product Type : **Earphone**

Product name : **ear(1)**

Applicant : **NOTHING TECHNOLOGY LIMITED**

Address : **11 Staple Inn, London, WC1V 7QH, United Kingdom**

Manufacturer : **NOTHING TECHNOLOGY LIMITED**

Address : **11 Staple Inn, London, WC1V 7QH, United Kingdom**

Test Result :  **Positive**  **Negative**

Total pages including  
Appendices : **61**

*Any use for advertising purposes must be granted in writing. This technical report may only be quoted in full. This report is the result of a single examination of the object in question and is not generally applicable evaluation of the quality of other products in regular production. For further details please see testing and certification regulation, chapter A-3.4.*



# 1 Table of Contents

- 1 Table of Contents .....2
- 2 Details about the Test Laboratory .....3
- 3 Description of the Equipment Under Test .....4
- 4 Summary of Test Standards .....5
- 5 Summary of Test Results .....6
- 6 General Remarks .....7
- 7 Test Setups .....8
- 8 Systems test configuration .....9
- 9 Technical Requirement ..... 10
  - 9.1 Conducted peak output power and e.i.r.p. .... 10
  - 9.2 20 dB bandwidth and 99% Occupied Bandwidth ..... 17
  - 9.3 Carrier Frequency Separation ..... 27
  - 9.4 Number of hopping frequencies ..... 30
  - 9.5 Dwell Time..... 32
  - 9.6 Spurious RF conducted emissions..... 36
  - 9.7 Band edge testing ..... 47
  - 9.8 Spurious radiated emissions for transmitter ..... 52
- 10 Test Equipment List..... 60
- 11 System Measurement Uncertainty ..... 61



## 2 Details about the Test Laboratory

### Details about the Test Laboratory

#### Test Site 1

Company name: TÜV SÜD Certification and Testing (China) Co., Ltd. Shenzhen Branch  
 Building 12&13, Zhiheng Wisdomland Business Park,  
 Nantou Checkpoint Road 2, Nanshan District,  
 Shenzhen City, 518052,  
 P. R. China

FCC Designation Number: CN5009

FCC Registration No.: 514049

IC Registration Number: 10320A

Telephone: 86 755 8828 6998

Fax: 86 755 8828 5299

#### Report Version:

Revision	Release Date	History/Memo.
N/A	2021-05-25	Initial Release

### 3 Description of the Equipment Under Test

Product:	ear(1)
Model no.:	B181
FCC ID:	2AZEQ-B181
IC:	27102-B181
PMN:	ear(1)
HVIN:	B181R
Rating:	3.7V
RF Transmission Frequency:	2402MHz-2480MHz
No. of Operated Channel:	79
Modulation:	GFSK, $\pi/4$ -DQPSK, 8DPSK
Antenna Type:	Internal antenna
Antenna Gain:	-3dBi max for 2.4GHz
Description of the EUT:	The Equipment Under Test (EUT) is Earphone with Bluetooth Low Energy/Bluetooth BDR+EDR functions.

## 4 Summary of Test Standards

Test Standards	
FCC Part 15 Subpart C 10-1-2020 Edition	PART 15 - RADIO FREQUENCY DEVICES Subpart C - Intentional Radiators
RSS-Gen Issue 5, Amendment 2, February 2021	General Requirements and Information for the Certification of Radio Apparatus
RSS-247 Issue 2 February 2017	Digital Transmission Systems (DTSS), Frequency Hopping Systems (FHSS) and License-Exempt Local Area Network (LE-LAN) Devices

All the test methods were according to Public Notice DA 00-705 -Frequency Hopper Spread Spectrum Test Procedure, KDB558074 D01 v05r02 and ANSI C63.10-2013.

## 5 Summary of Test Results

Technical Requirements				
FCC Part 15 Subpart C/ RSS-247 Issue 2/RSS-Gen Issue 5				
Test Condition			Test Site	Test Result
§15.207	RSS-GEN 8.8	Conducted emission AC power port	--	N/A
§15.247(b)(1)	RSS-247 Clause 5.4(b)	Conducted peak output power and e.i.r.p.	Site 1	PASS
§15.247(e)	RSS-247 Clause 5.2(b)	Power spectral density	--	N/A
§15.247(a)(2)	RSS-247 Clause 5.2(a)	6dB bandwidth	--	N/A
§15.247(a)(1)	RSS-247 Clause 5.1(a) & RSS-Gen 6.7	20dB bandwidth and 99% Occupied Bandwidth	Site 1	PASS
§15.247(a)(1)	RSS-247 Clause 5.1(b)	Carrier frequency separation	Site 1	PASS
§15.247(a)(1)(iii)	RSS-247 Clause 5.1(d)	Number of hopping frequencies	Site 1	PASS
§15.247(a)(1)(iii)	RSS-247 Clause 5.1(d)	Dwell Time	Site 1	PASS
§15.247(d)	RSS-247 Clause 5.5	Spurious RF conducted emissions	Site 1	PASS
§15.247(d)	RSS-247 Clause 5.5	Band edge	Site 1	PASS
§15.247(d) & §15.209 & §15.205	RSS-247 Clause 5.5 & RSS-GEN 6.13 RSS-GEN 8.9 RSS-GEN 8.10	Spurious radiated emissions for transmitter and receiver	Site 1	PASS
§15.203	RSS-GEN 6.8	Antenna requirement	See note 2	PASS

Note 1: N/A=Not Applicable.

Note 2: The EUT uses a monopole antenna, which gain is -3dBi. In accordance to §15.203 and RSS-GEN 6.8, it is considered sufficiently to comply with the provisions of this section.



## 6 General Remarks

### Remarks

This submittal(s) (test report) is intended for FCC ID: 2AZEQ-B181, IC: 27102-B181, complies with Section 15.205, 15.209, 15.247 of the FCC Part 15, Subpart C and RSS-247 issue 2 and RSS-Gen issue 5 rules.

The Equipment Under Test (EUT) is Earphone with Bluetooth Low Energy/Bluetooth BDR+EDR functions.

Note: The report is for BDR+EDR only.

### SUMMARY:

All tests according to the regulations cited on page 5 were

■ - Performed

□ - **Not** Performed

The Equipment Under Test

■ - **Fulfills** the general approval requirements.

□ - **Does not** fulfill the general approval requirements.

Sample Received Date: 2021-04-30

Testing Start Date: 2021-04-30

Testing End Date: 2021-05-14

- TÜV SÜD Certification and Testing (China) Co., Ltd. Shenzhen Branch –

Reviewed by:

Prepared by:

Tested by:



John Zhi  
Project Manager

Joe Gu  
Project Engineer

Carry Cai  
Test Engineer

## 7 Test Setups

### 7.1 Radiated test setups

#### Below 1GHz

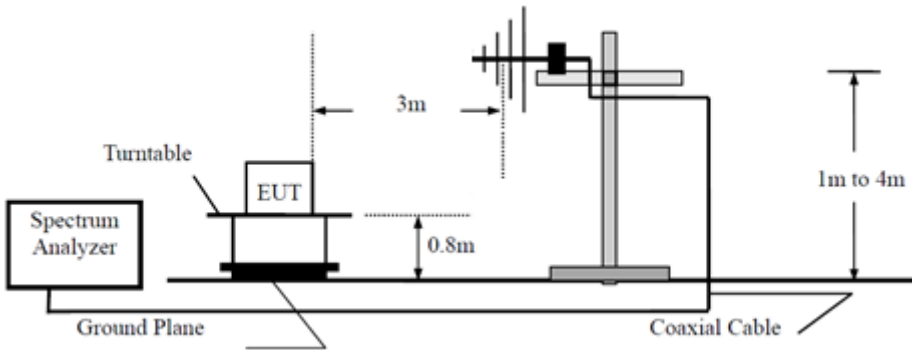

#### Above 1GHz

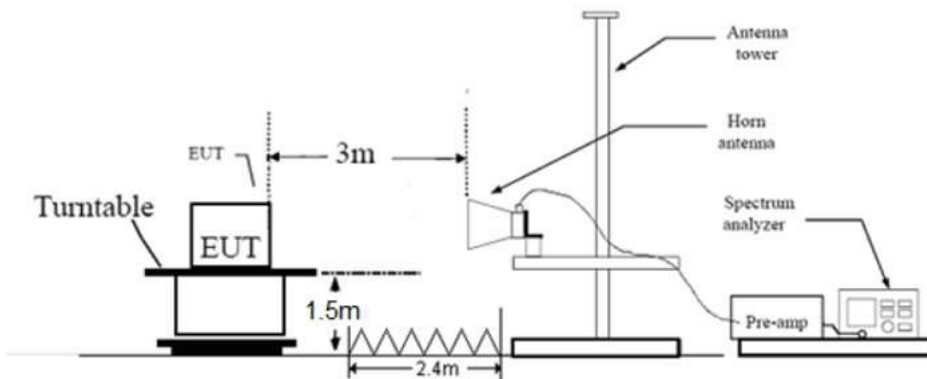

### 7.2 Conducted RF test setups

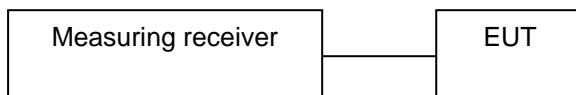



## 8 Systems test configuration

Auxiliary Equipment Used during Test:

Name	Model	Manufacturer	S/N	Cal Due Date
Notebook	X220	Lenovo	--	--

The system was configured to hopping mode and non-hopping mode.

Hopping mode: typical working mode (normal hopping status)

Non-hopping mode: The system was configured to operate at a signal channel transmitting. The test software allows the configuration and operation at the worst-case duty and the highest transmit power.

## 9 Technical Requirement

### 9.1 Conducted peak output power and e.i.r.p.

#### Test Method

1. The EUT was placed on 0.8m height table, the RF output of EUT was connected to the test receiver by RF cable. The path loss was compensated to the results for each measurement.
2. Use the following spectrum analyzer settings:  
Span = approximately 5 times the 20dB bandwidth, centered on a hopping channel  
RBW > the 20dB bandwidth of the emission being measured, VBW ≥ RBW,  
Sweep = auto, Detector function = peak, Trace = max hold
3. Allow the trace to stabilize. Use the marker-to-peak function to set the marker to the peak of the emission. The indicated level is the peak output power

#### Limits

Conducted Peak Output Power:

Frequency Range MHz	Limit W	Limit dBm
2400-2483.5	≤1	≤30

For e.i.r.p.:

Frequency Range MHz	Limit W	Limit dBm
2400-2483.5	≤4	≤36

**Conducted peak output power**

**Bluetooth Mode GFSK modulation Test Result**

Frequency MHz	Conducted Peak Output Power dBm	Antenna Gain dBi	EIRP dBm	Result
Low channel 2402MHz	11.61	-3	8.61	Pass
Middle channel 2441MHz	11.32	-3	8.32	Pass
High channel 2480MHz	11.41	-3	8.41	Pass

Low channel 2402MHz

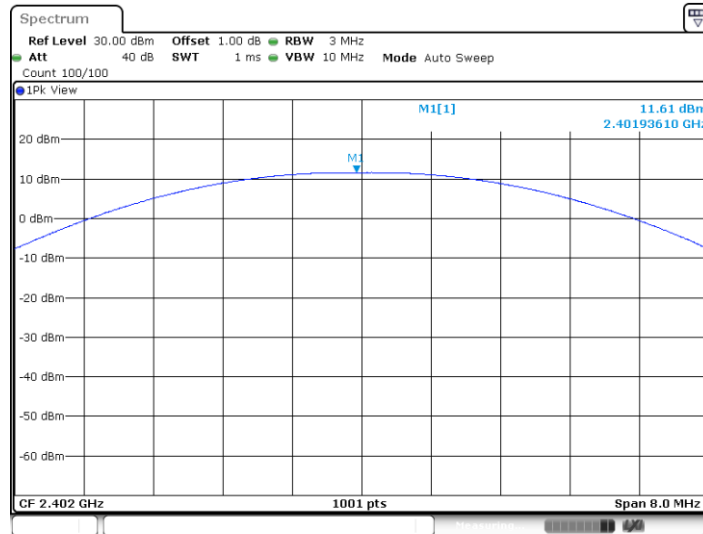

Date: 11.MAY.2021 20:04:27

### Middle channel 2441MHz

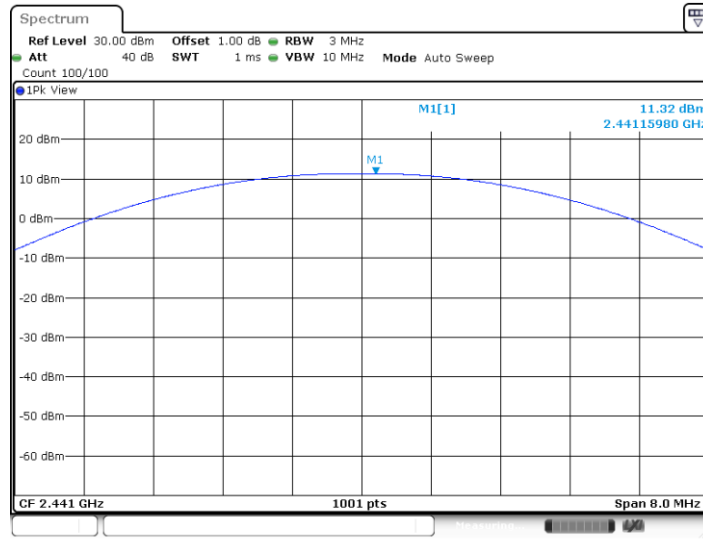

Date: 11.MAY.2021 20:05:57

### High channel 2480MHz

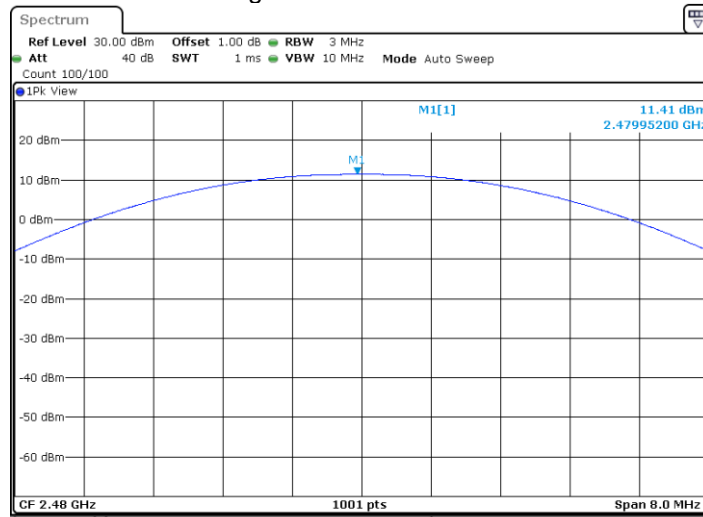

Date: 11.MAY.2021 20:06:22



Bluetooth Mode  $\pi/4$ -DQPSK modulation Test Result

Frequency MHz	Conducted Peak Output Power dBm	Antenna Gain dBi	EIRP dBm	Result
Low channel 2402MHz	11.61	-3	8.61	Pass
Middle channel 2441MHz	11.37	-3	8.37	Pass
High channel 2480MHz	11.45	-3	8.45	Pass

Low channel 2402MHz

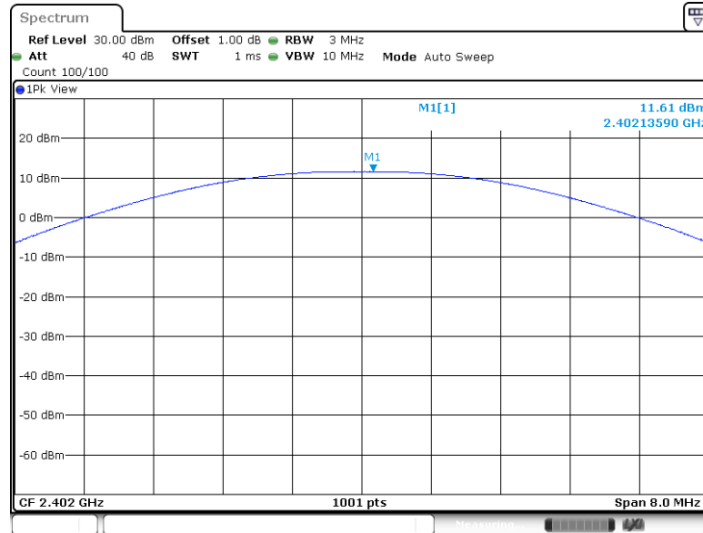

Date: 11.MAY.2021 20:06:50

### Middle channel 2441MHz

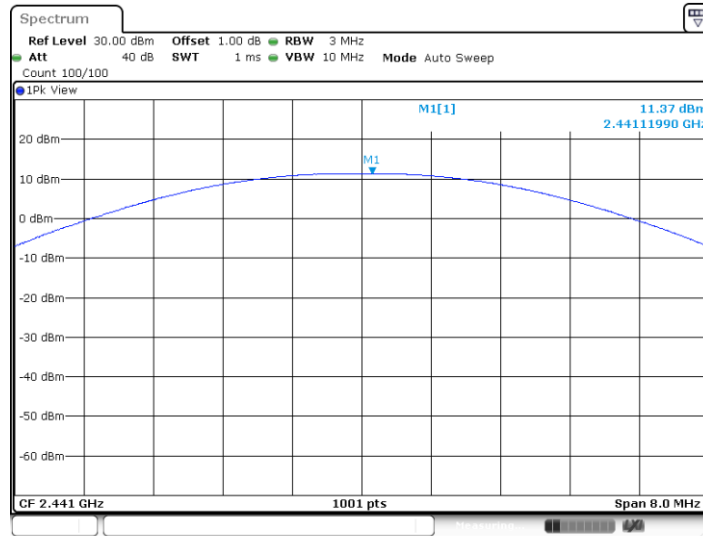

Date: 11.MAY.2021 20:07:17

### High channel 2480MHz

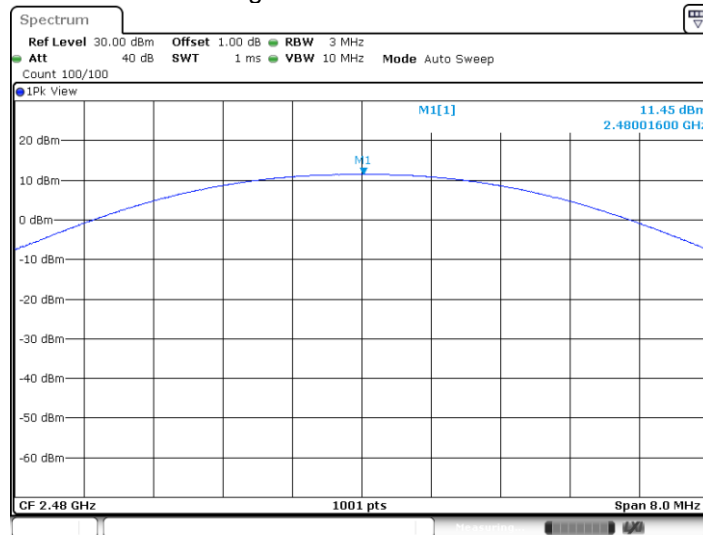

Date: 11.MAY.2021 20:07:42



Bluetooth Mode 8DPSK modulation Test Result

Frequency MHz	Conducted Peak Output Power dBm	Antenna Gain dBi	EIRP dBm	Result
Low channel 2402MHz	11.61	-3	8.61	Pass
Middle channel 2441MHz	11.34	-3	8.34	Pass
High channel 2480MHz	11.42	-3	8.42	Pass

Low channel 2402MHz

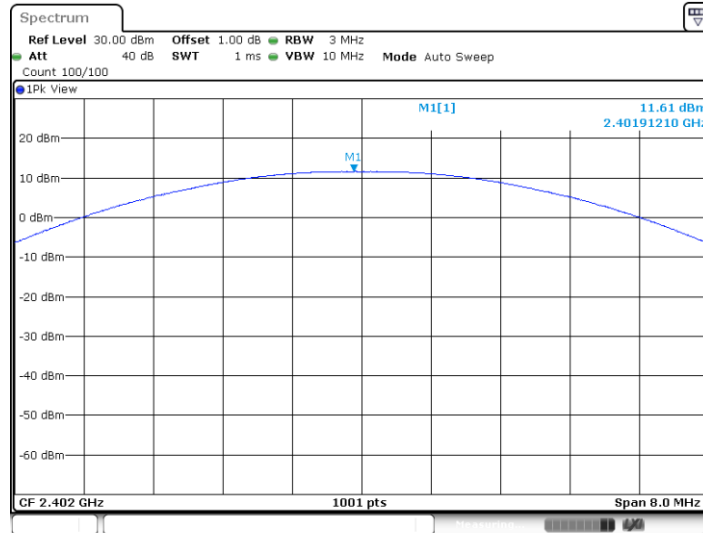

Date: 11.MAY.2021 20:08:09

### Middle channel 2441MHz

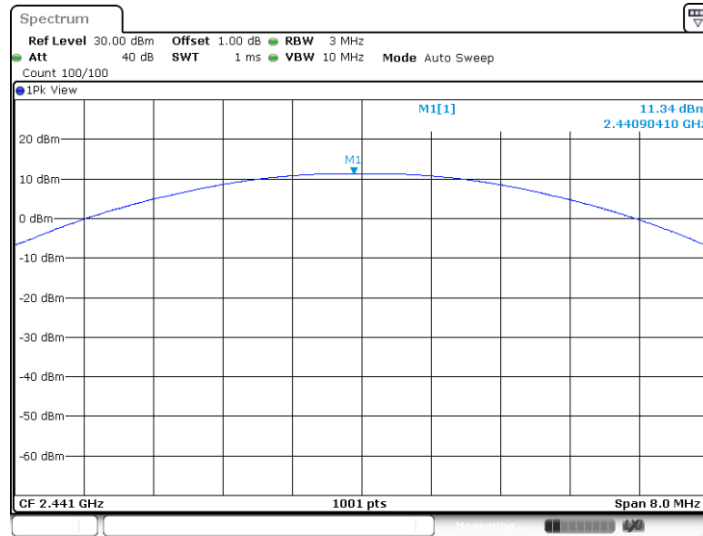

Date: 11.MAY.2021 22:54:55

### High channel 2480MHz

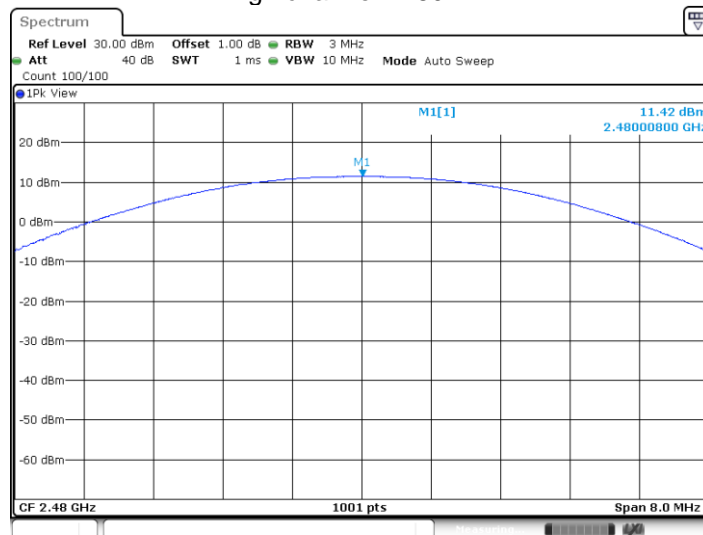

Date: 11.MAY.2021 22:55:15



## 9.2 20 dB bandwidth and 99% Occupied Bandwidth

### Test Method

1. Check the calibration of the measuring instrument using either an internal calibrator or a known signal from an external generator.
2. Position the EUT without connection to measurement instrument. Turn on the EUT and connect it to measurement instrument. Then set it to any one convenient frequency within its operating range. Set a reference level on the measuring instrument equal to the highest peak value.
3. Measure the frequency difference of two frequencies that were attenuated 20 dB from the reference level. Record the frequency difference as the emission bandwidth.
4. Repeat above procedures until all frequencies measured were complete.

### Limit

Limit [kHz]

---

N/A

## 20 dB bandwidth and 99% Occupied Bandwidth

### Bluetooth Mode GFSK Modulation test result

Frequency MHz	20 dB Bandwidth kHz	99% Bandwidth kHz	Limit kHz	Result
2402	1107	905	--	Pass
2441	1104	905	--	Pass
2480	1104	908	--	Pass

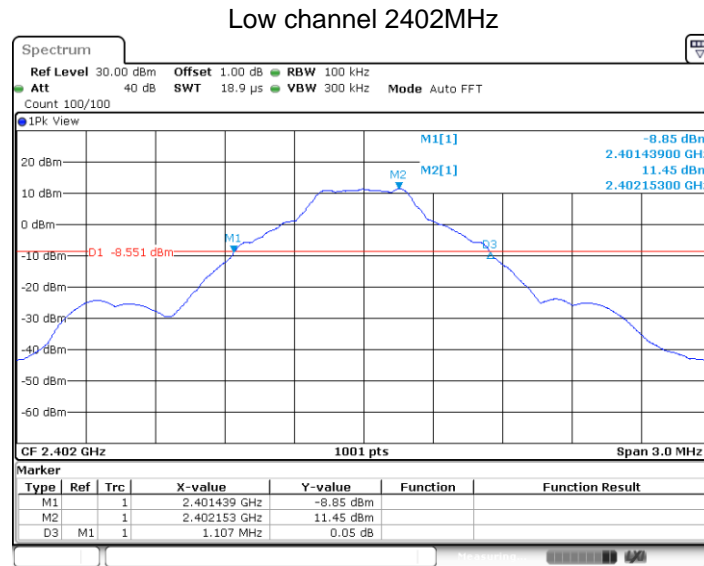

Date: 11.MAY.2021 19:13:27

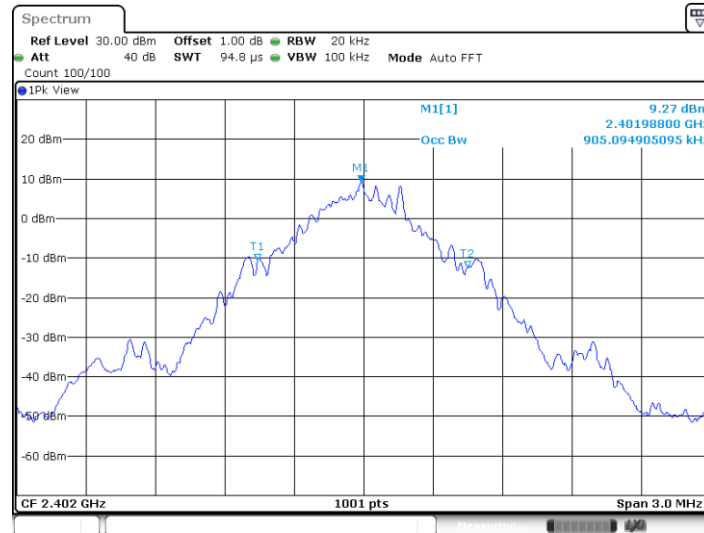

Date: 11.MAY.2021 19:13:37

Middle channel 2441MHz

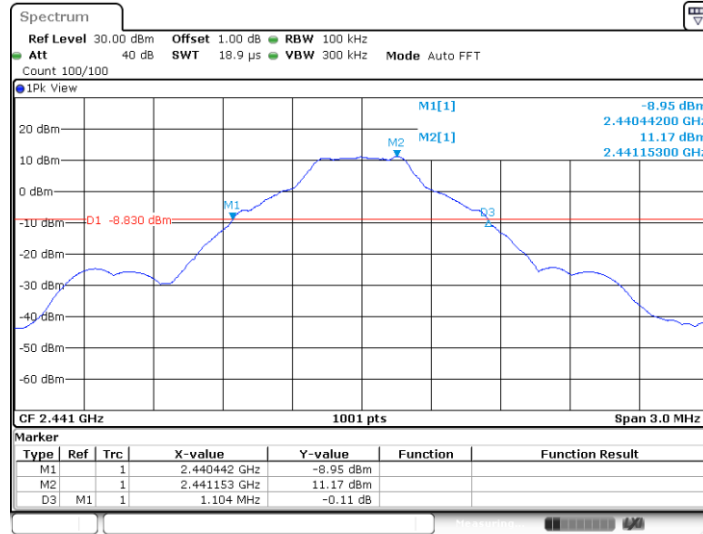

Date: 11.MAY.2021 19:17:40



Date: 11.MAY.2021 19:17:51

### High channel 2480MHz

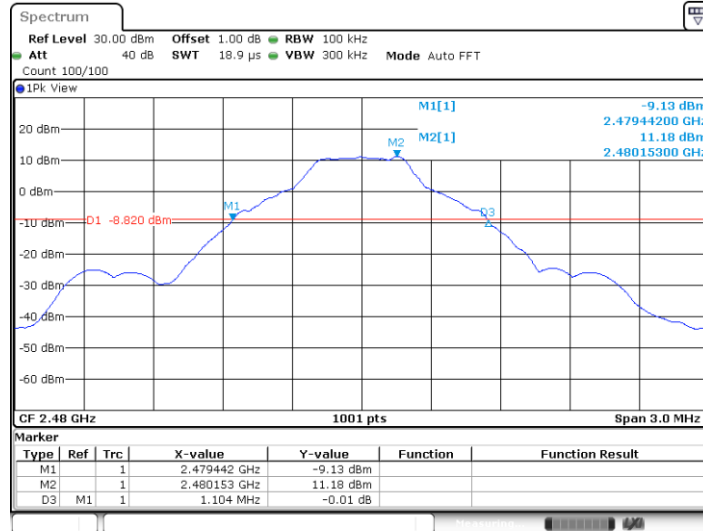

Date: 11.MAY.2021 19:20:35



Date: 11.MAY.2021 19:20:46

## 20 dB bandwidth and 99% Occupied Bandwidth

### Bluetooth Mode $\pi/4$ -DQPSK Modulation test result

Frequency MHz	20 dB Bandwidth kHz	99% Bandwidth kHz	Limit kHz	Result
2402	1404	1199	--	Pass
2441	1395	1193	--	Pass
2480	1380	1178	--	Pass

Low channel 2402MHz

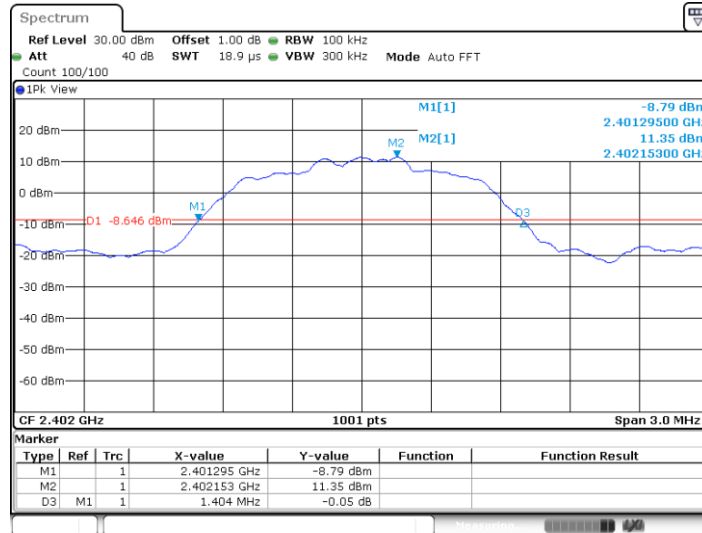

Date: 11.MAY.2021 19:22:42



Date: 11.MAY.2021 19:22:53

### Middle channel 2441MHz

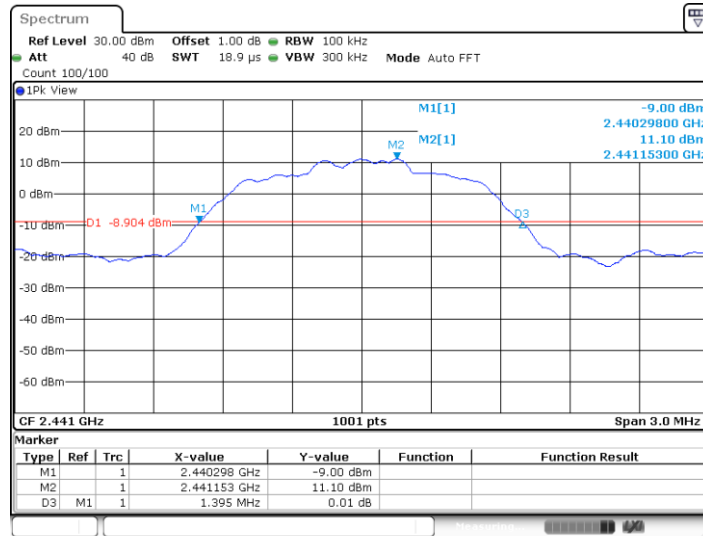

Date: 11.MAY.2021 19:24:54



Date: 11.MAY.2021 19:25:05

### High channel 2480MHz

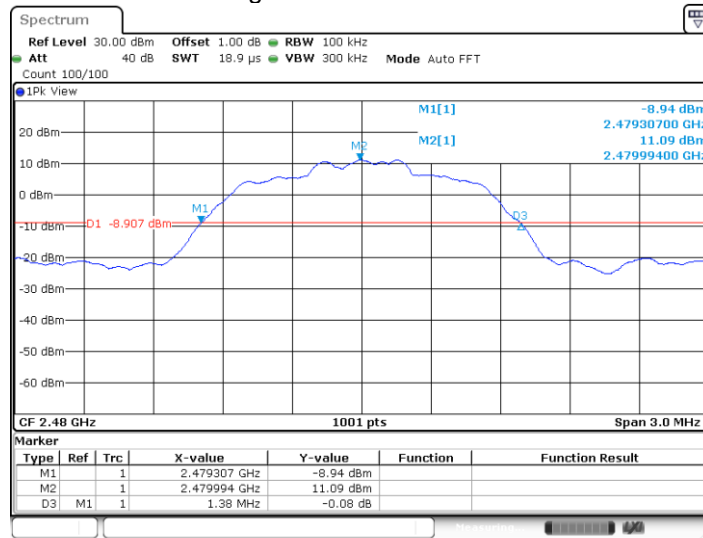

Date: 11.MAY.2021 19:27:11



Date: 11.MAY.2021 19:27:22

## 20 dB bandwidth and 99% Occupied Bandwidth

### Bluetooth Mode 8DPSK Modulation test result

Frequency MHz	20 dB Bandwidth kHz	99% Bandwidth kHz	Limit kHz	Result
2402	1392	1211	--	Pass
2441	1395	1205	--	Pass
2480	1374	1184	--	Pass

Low channel 2402MHz

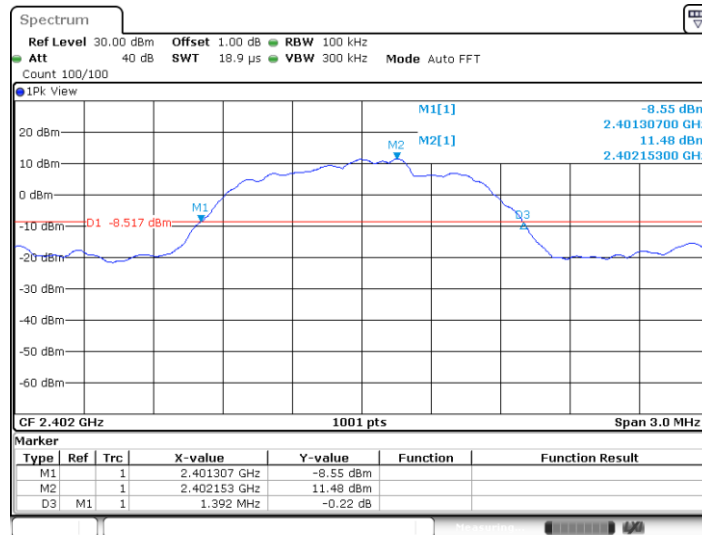

Date: 11.MAY.2021 19:29:04



Date: 11.MAY.2021 19:29:15



Middle channel 2441MHz

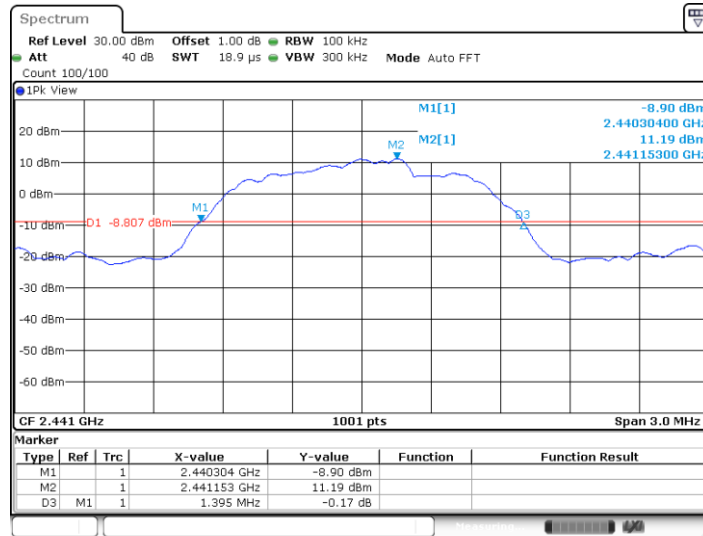

Date: 11.MAY 2021 19:30:52

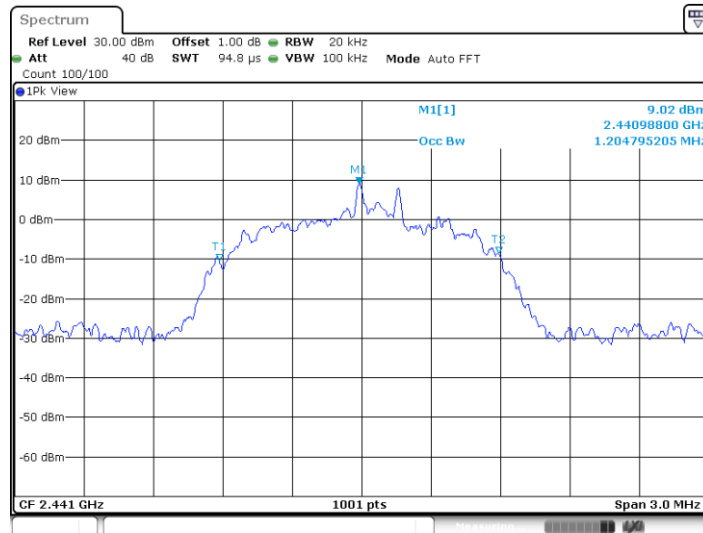

Date: 11.MAY 2021 19:31:02

### High channel 2480MHz

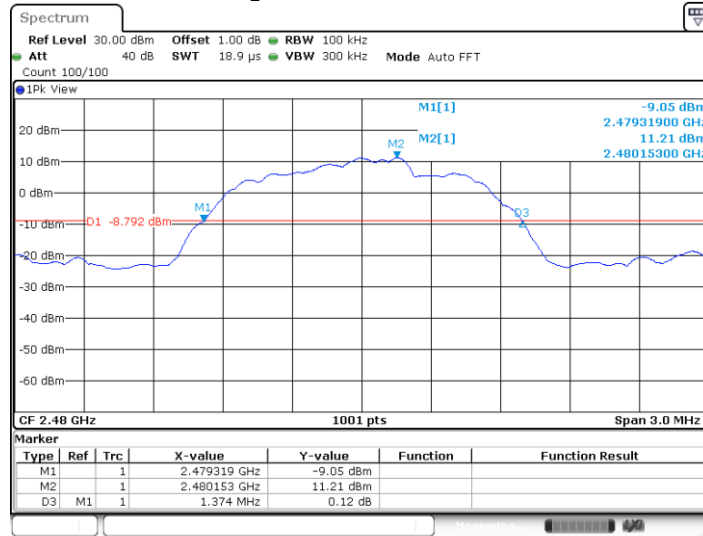

Date: 11.MAY.2021 19:33:25

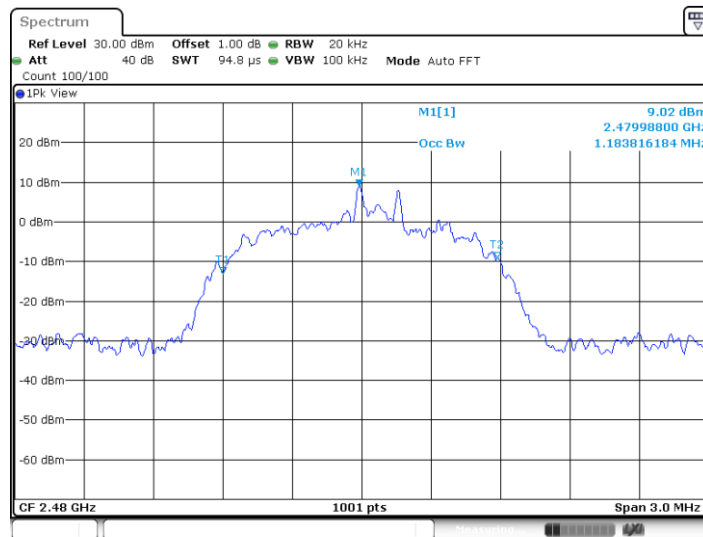

Date: 11.MAY.2021 19:33:36

## 9.3 Carrier Frequency Separation

### Test Method

1. Use the following spectrum analyzer settings:  
Span = wide enough to capture the peaks of two adjacent channels,  $RBW \geq 1\%$  of the span,  $VBW \geq RBW$ , Sweep = auto, Detector function = peak
2. By using the Max-Hold function record the separation of two adjacent channels.
3. Measure the frequency difference of these two adjacent channels by spectrum analyzer marker function.
4. Repeat above procedures until all frequencies measured were complete.

### Limit

Limit  
kHz

---

$\geq 25\text{kHz}$  or  $2/3$  of the 20 dB bandwidth which is greater

### Carrier Frequency Separation

TestMode	Channel	Result[MHz]	Limit[MHz]	Verdict
DH5	Hop	1.014	>=0.738	PASS
2DH5	Hop	1.157	>=0.936	PASS
3DH5	Hop	1.003	>=0.930	PASS

#### DH5

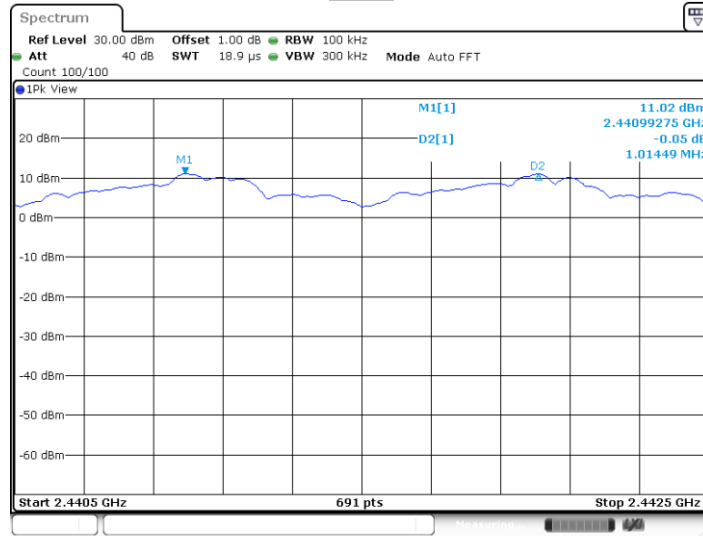

Date: 11.MAY.2021 19:35:30

### 2DH5

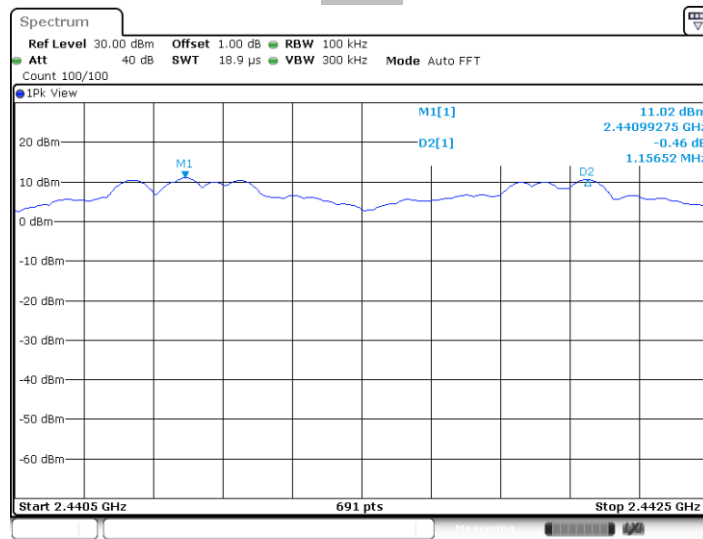

Date: 11.MAY.2021 22:58:32

### 3DH5

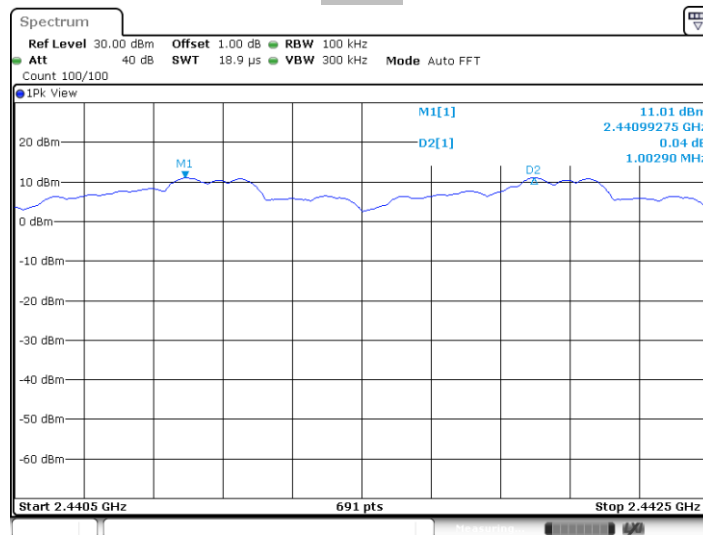

Date: 11.MAY.2021 20:01:18

## 9.4 Number of hopping frequencies

### Test Method

1. Use the following spectrum analyzer settings:  
Span = wide enough to capture the peaks of two adjacent channels,  $RBW \geq 1\%$  of the span,  $VBW \geq RBW$ , Sweep = auto, Detector function = peak
2. Set the spectrum analyzer on Max-Hold Mode, and then keep the EUT in hopping mode.
3. Record all the signals from each channel until each one has been recorded.
4. Repeat above procedures until all frequencies measured were complete.

### Limit

Limit  
number  
—————  
 $\geq 15$

## Number of hopping frequencies

Test result: The measurement was performed with the typical configuration (normal hopping status), and the total hopping channels is constant for the all modulation mode according with the Bluetooth Core Specification. Here GFSK modulation mode was used to show compliance.

Number of hopping frequencies	Result
79	Pass

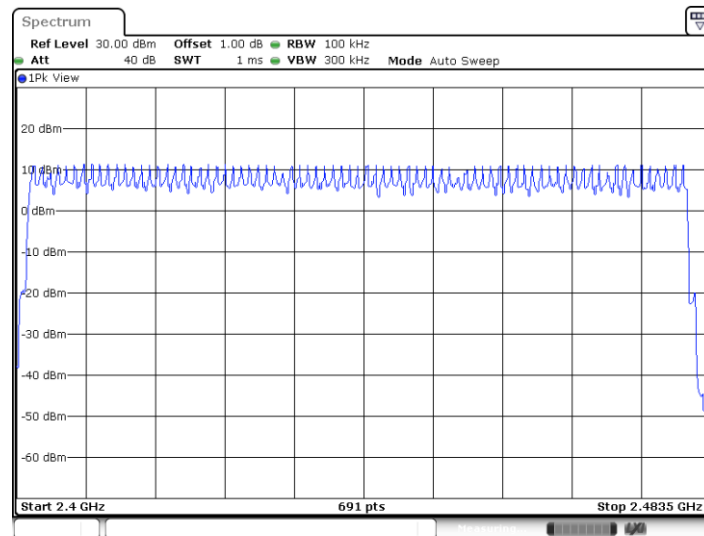

Date: 11.MAY.2021 19:36:05

## 9.5 Dwell Time

### Test Method

1. Connect EUT antenna terminal to the spectrum analyzer with a low loss cable.  
Equipment mode: Spectrum analyzer
2. RBW: 1MHz; VBW: 1MHz; SPAN: Zero Span
3. Adjust the center frequency of spectrum analyzer on any frequency be measured.
4. Measure the Dwell Time by spectrum analyzer Marker function.
5. Repeat above procedures until all frequencies measured were complete.

### Limit

The average time of occupancy on any frequency shall not be greater than 0.4 seconds within a period of 0.4 seconds multiplied by the number of hopping channels employed.



## Dwell Time

### Dwell time

The maximum dwell time shall be 0.4 s.

The Dwell Time = Burst Width \* Total Hops. The detailed calculations are showed as follows:  
 The duration for dwell time calculation: 0.4 [s] \* hopping number = 0.4 [s] \* 79 [ch] = 31.6 [s\*ch];

### Test Result

TestMode	Channel	BurstWidth (ms)	TotalHops	Result(s)	Limit(s)	Verdict
DH5	Hop	2.89	100	0.289	<=0.4	PASS
2DH5	Hop	2.89	110	0.318	<=0.4	PASS
3DH5	Hop	2.89	90	0.260	<=0.4	PASS

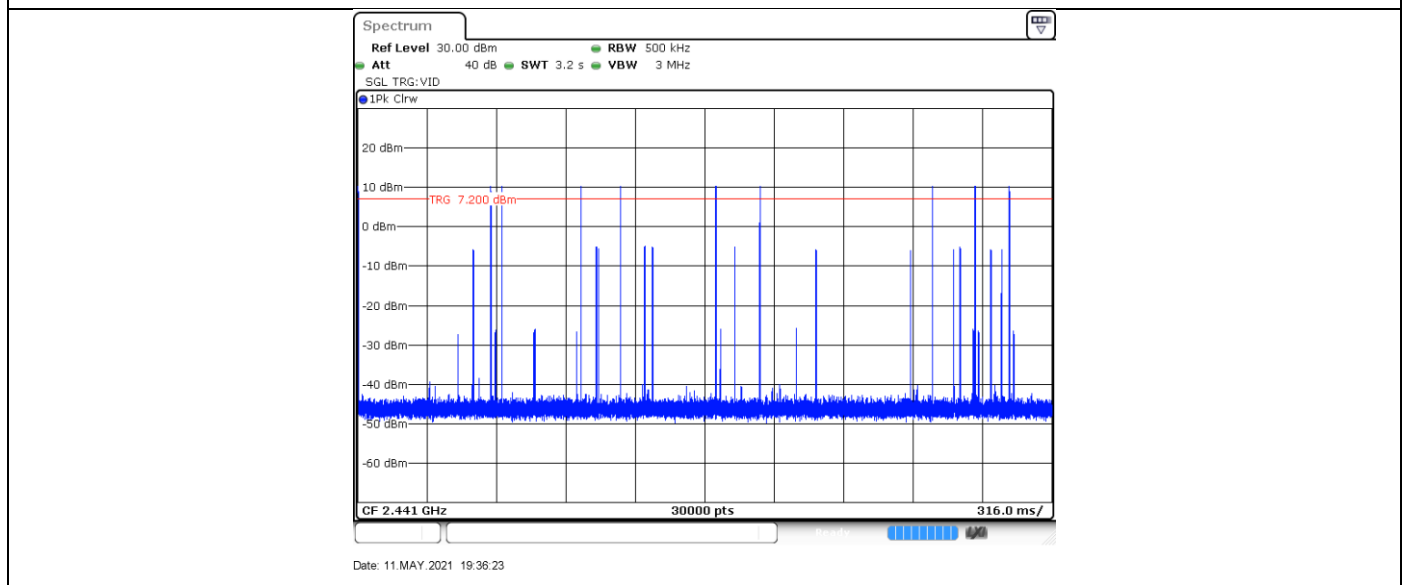
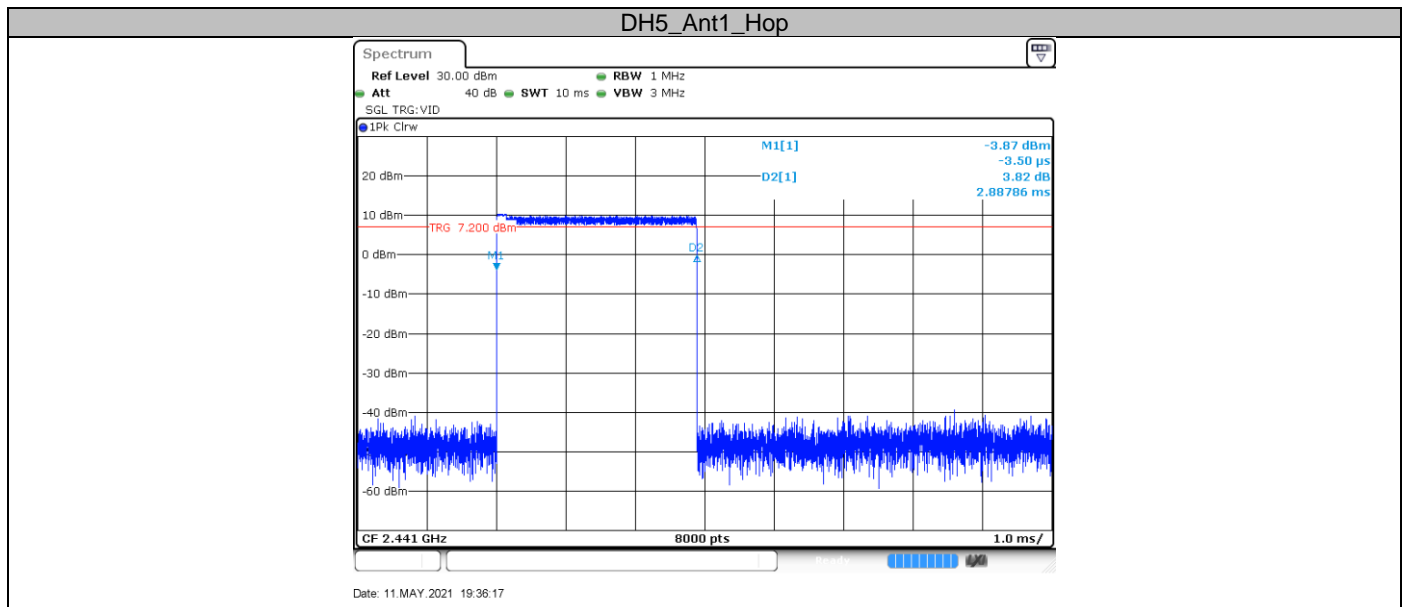

### 2DH5\_Ant1\_Hop

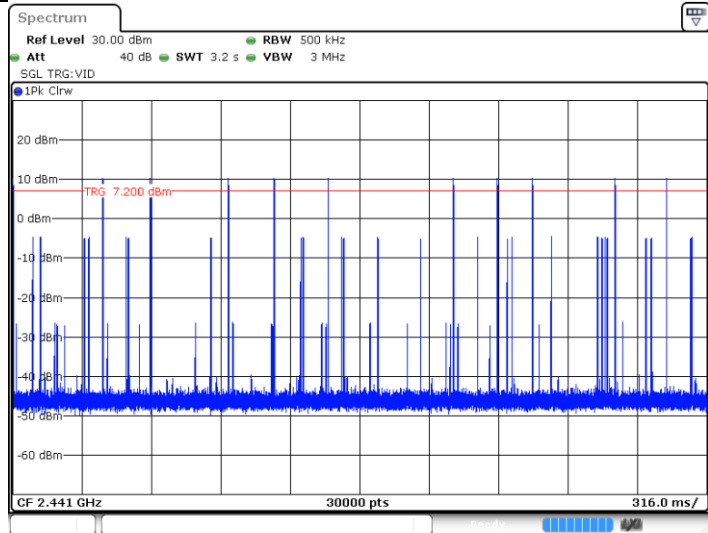
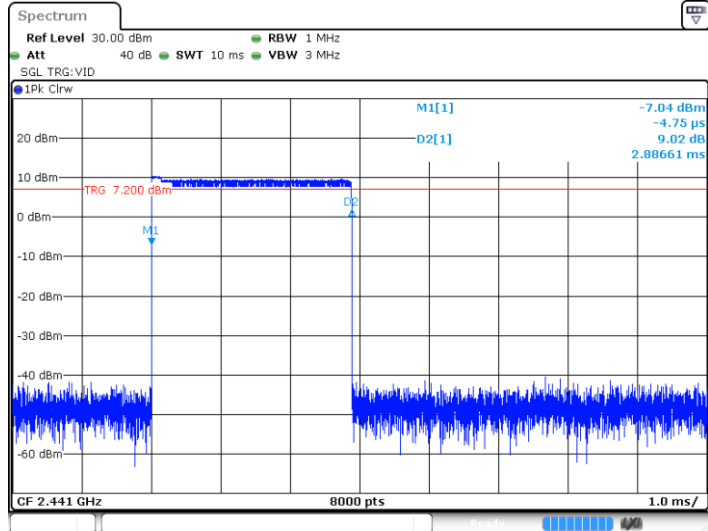

### 3DH5\_Ant1\_Hop

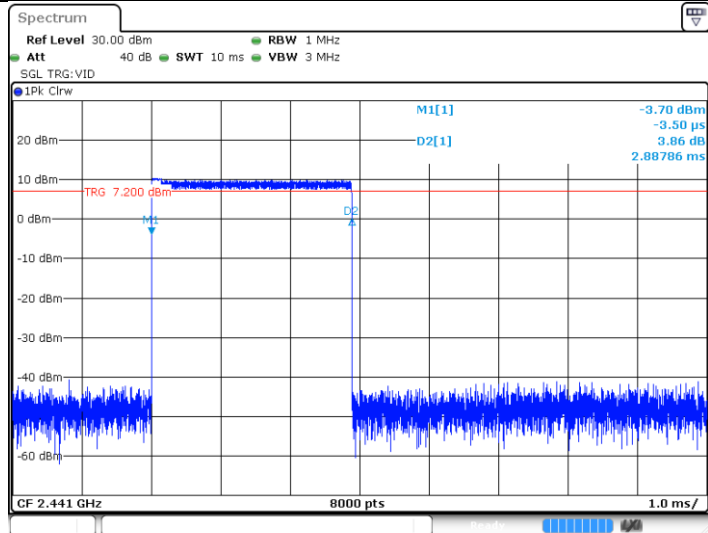

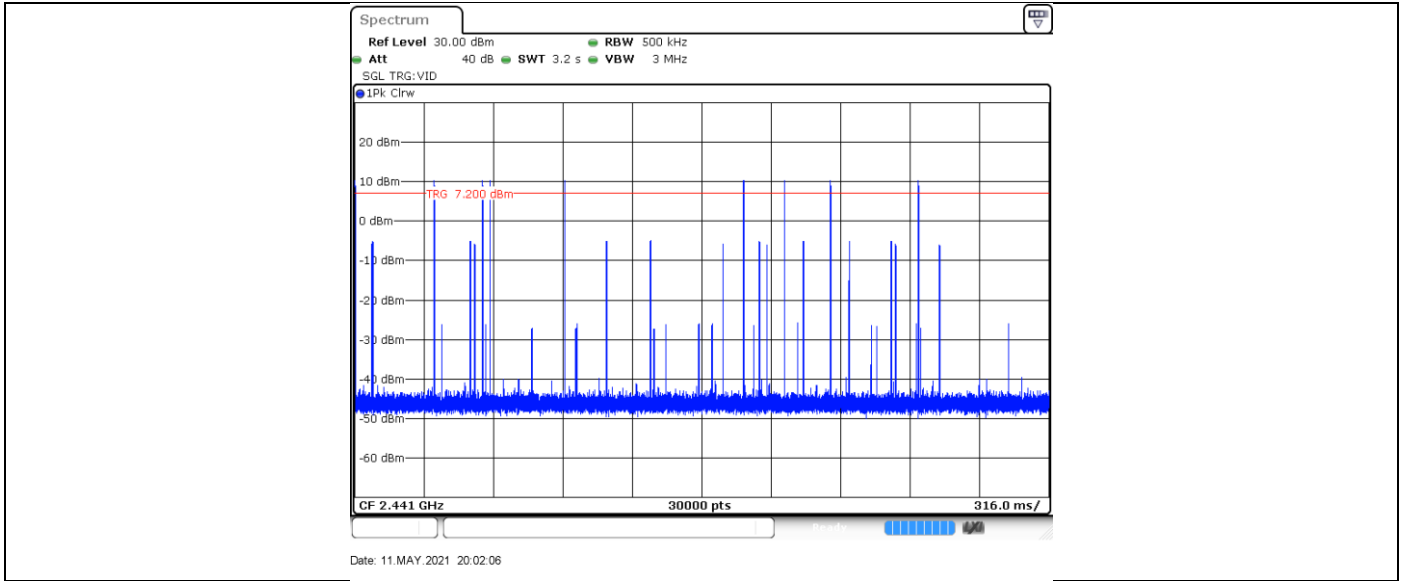

## 9.6 Spurious RF conducted emissions

### Test Method

1. Use the following spectrum analyzer settings:  
Span = wide enough to capture the peak level of the in-band emission and all spurious emissions (e.g., harmonics) from the lowest frequency generated in the EUT up through the 10<sup>th</sup> harmonic. Typically, several plots are required to cover this entire span.  
RBW = 100 kHz, VBW $\geq$ RBW, Sweep = auto, Detector function = peak, Trace = max hold
2. Allow the trace to stabilize. Set the marker on the peak of any spurious emission recorded.
3. The level displayed must comply with the limit specified in this Section. Submit these plots.
4. Repeat above procedures until all frequencies measured were complete.

### Limit

Frequency Range MHz	Limit (dBc)
30-25000	-20



**Spurious RF conducted emissions**

TestMode	Antenna	Channel(MHz)	FreqRange(MHz)	RefLevel	Result(dBm)	Limit(dBm)	Verdict
DH5	Ant1	2402	Reference	11.57(dBm)	11.57	---	PASS
			30~1000	30~1000(MHz)	-67.9	<=-8.43	PASS
			1000~26500	1000~26500(MHz)	-20.03	<=-8.43	PASS
		2441	Reference	11.06(dBm)	11.06	---	PASS
			30~1000	30~1000(MHz)	-67.95	<=-8.94	PASS
			1000~26500	1000~26500(MHz)	-23.08	<=-8.94	PASS
		2480	Reference	11.25(dBm)	11.25	---	PASS
			30~1000	30~1000(MHz)	-68.47	<=-8.75	PASS
			1000~26500	1000~26500(MHz)	-29.13	<=-8.75	PASS
2DH5	Ant1	2402	Reference	11.48(dBm)	11.48	---	PASS
			30~1000	30~1000(MHz)	-67.68	<=-8.52	PASS
			1000~26500	1000~26500(MHz)	-29.17	<=-8.52	PASS
		2441	Reference	10.97(dBm)	10.97	---	PASS
			30~1000	30~1000(MHz)	-67.94	<=-9.03	PASS
			1000~26500	1000~26500(MHz)	-31.4	<=-9.03	PASS
		2480	Reference	11.19(dBm)	11.19	---	PASS
			30~1000	30~1000(MHz)	-68.26	<=-8.81	PASS
			1000~26500	1000~26500(MHz)	-36.76	<=-8.81	PASS
3DH5	Ant1	2402	Reference	11.59(dBm)	11.59	---	PASS
			30~1000	30~1000(MHz)	-68.19	<=-8.41	PASS
			1000~26500	1000~26500(MHz)	-25.72	<=-8.41	PASS
		2441	Reference	11.08(dBm)	11.08	---	PASS
			30~1000	30~1000(MHz)	-68.76	<=-8.92	PASS
			1000~26500	1000~26500(MHz)	-33.44	<=-8.92	PASS
		2480	Reference	11.28(dBm)	11.28	---	PASS
			30~1000	30~1000(MHz)	-68.76	<=-8.72	PASS
			1000~26500	1000~26500(MHz)	-35.68	<=-8.72	PASS

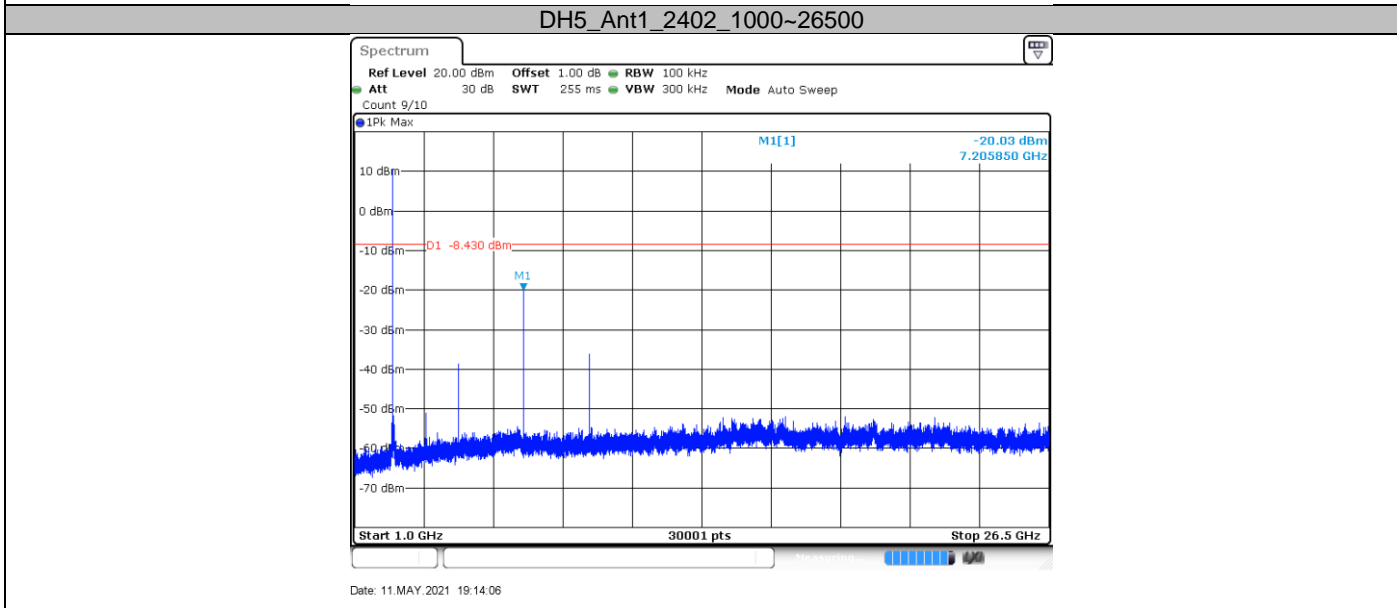
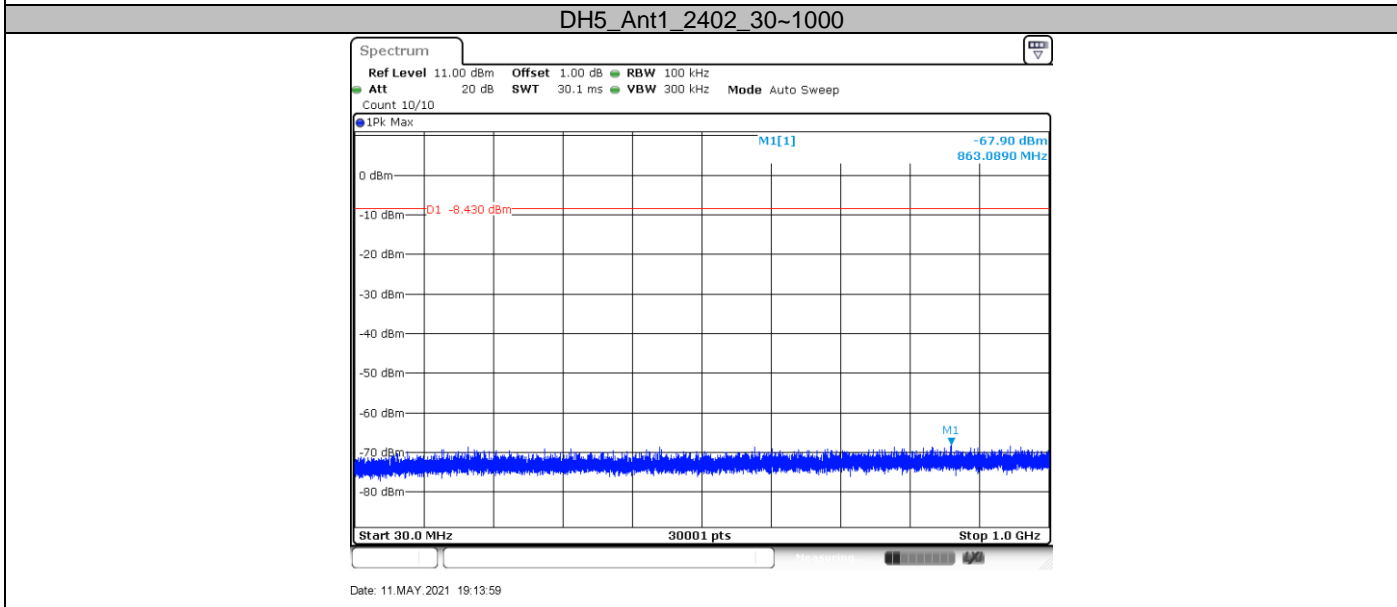
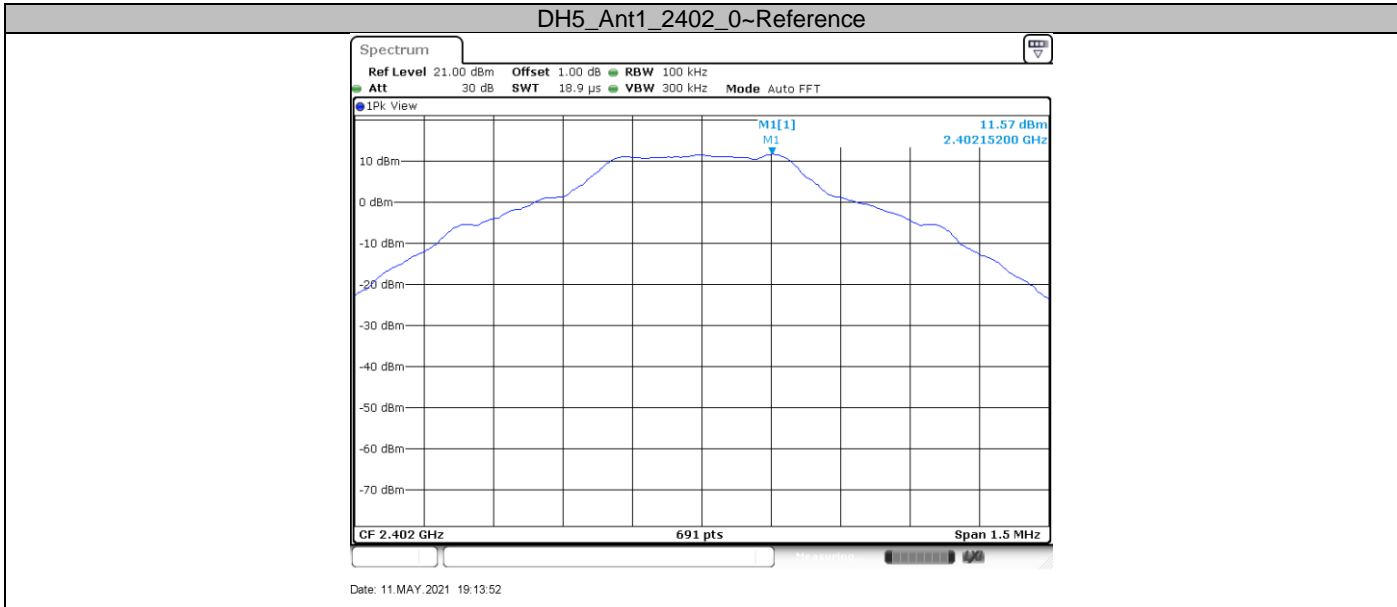

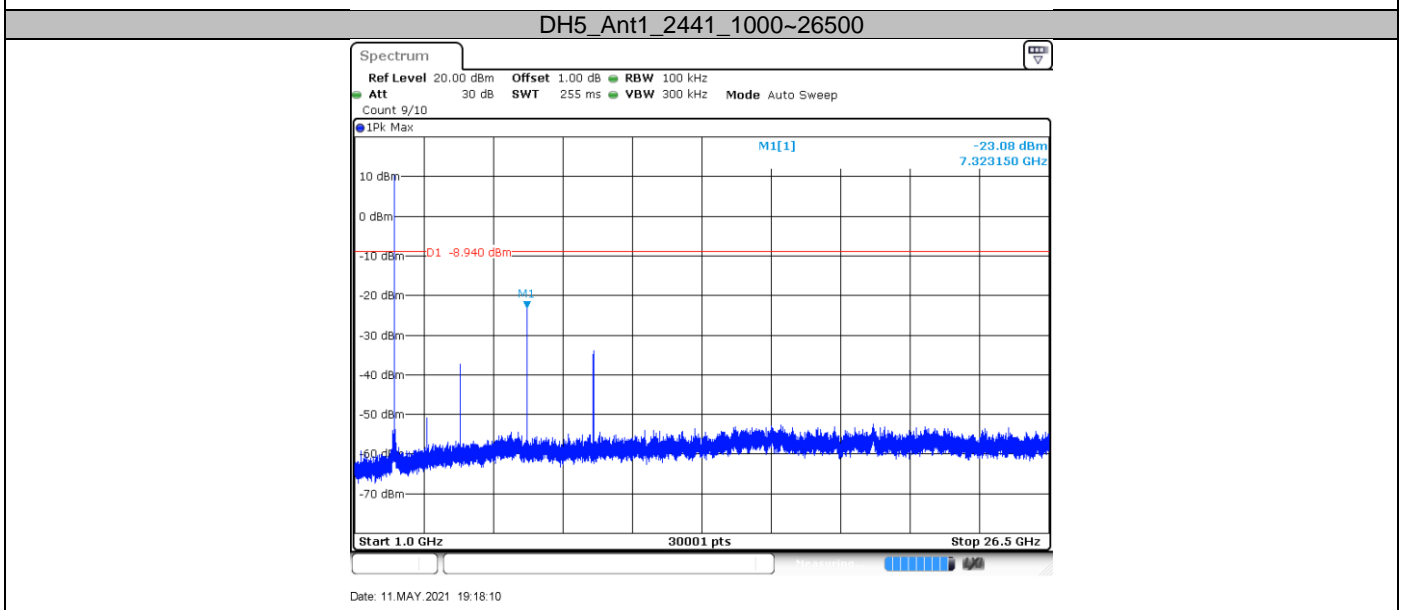
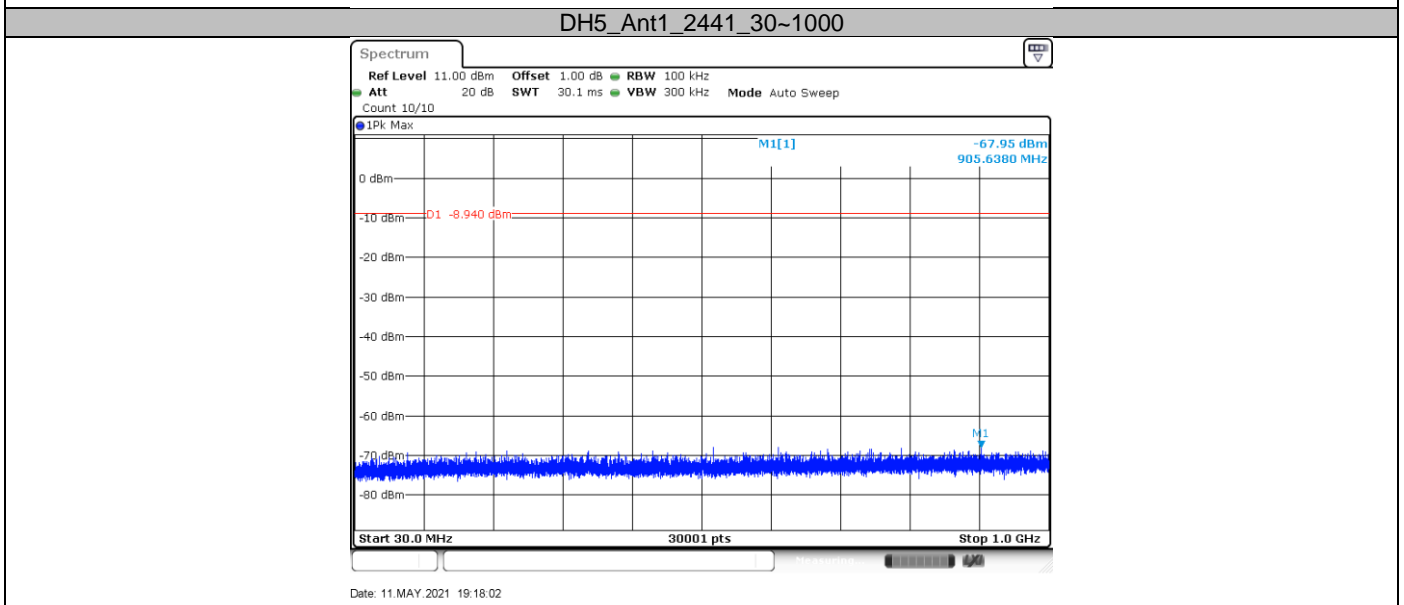
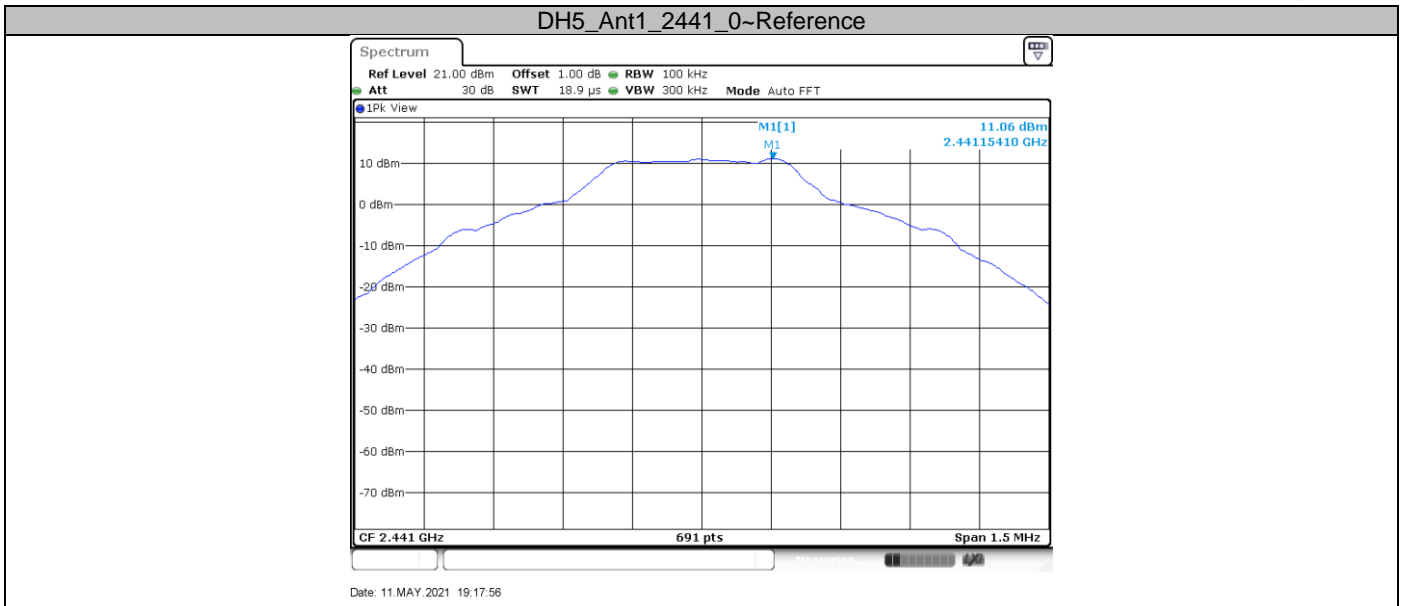

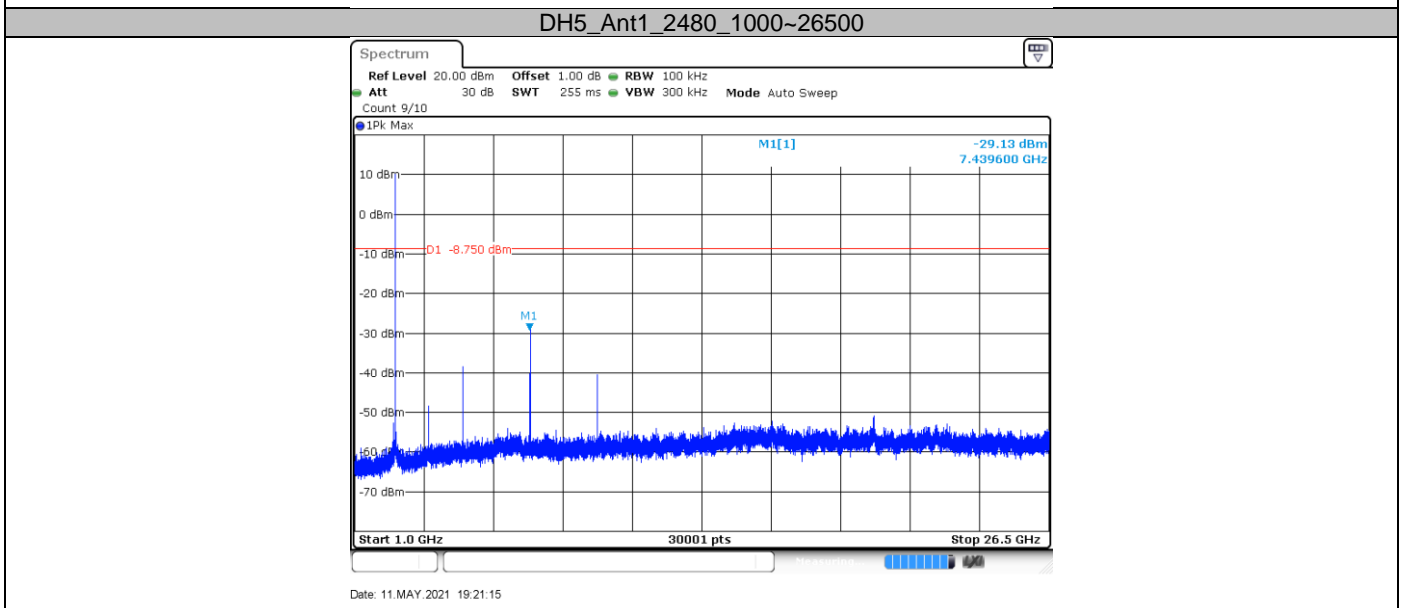
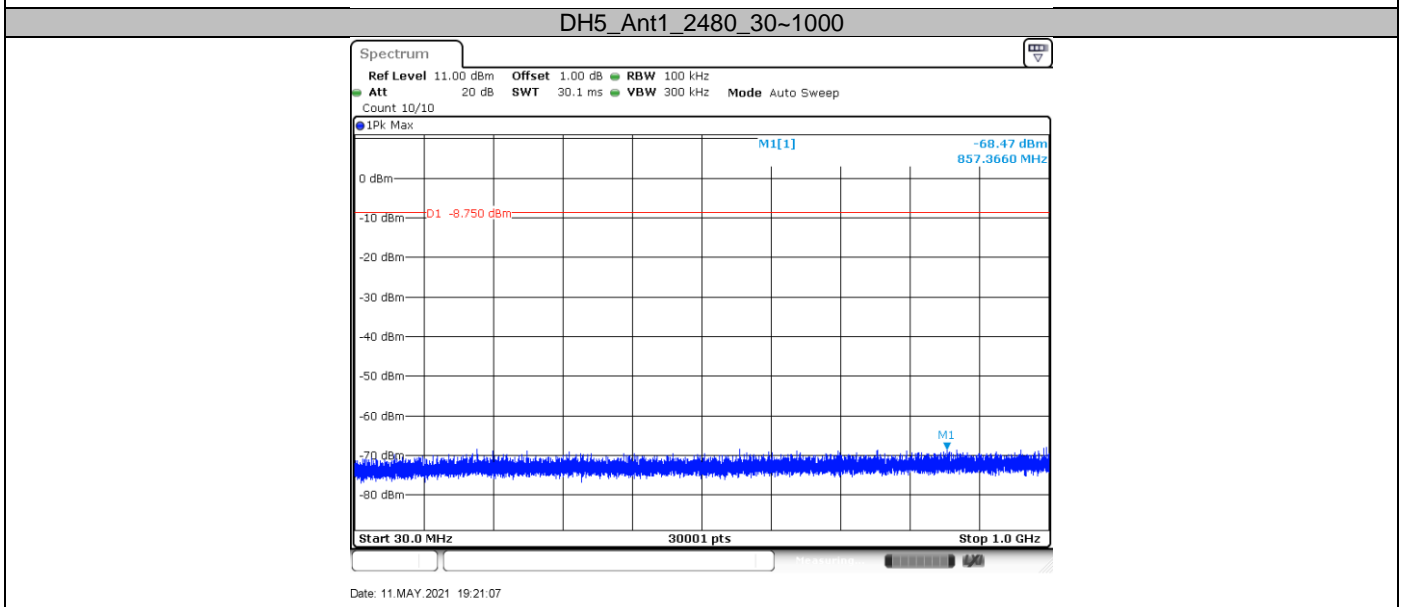
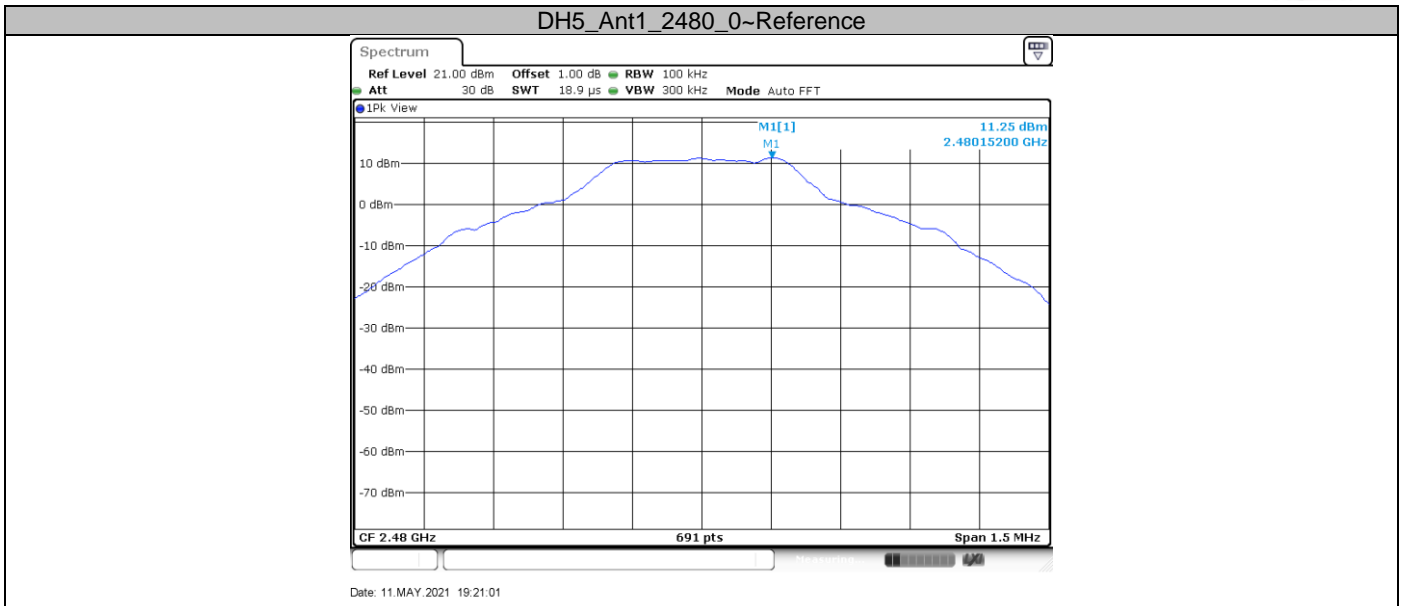



2DH5\_Ant1\_2402\_0~Reference

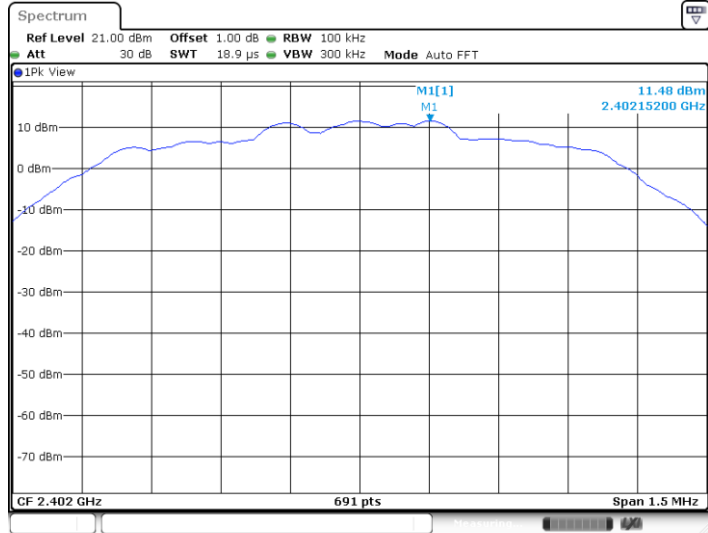

Date: 11.MAY.2021 19:23:08

2DH5\_Ant1\_2402\_30~1000

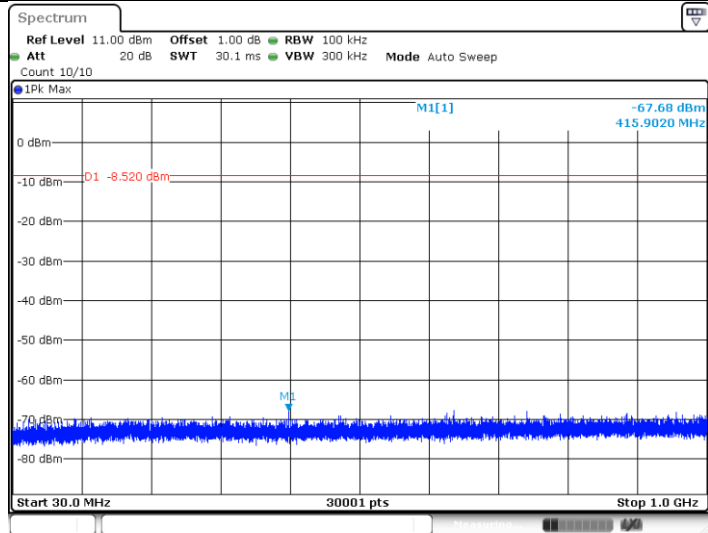

Date: 11.MAY.2021 19:23:14

2DH5\_Ant1\_2402\_1000~26500

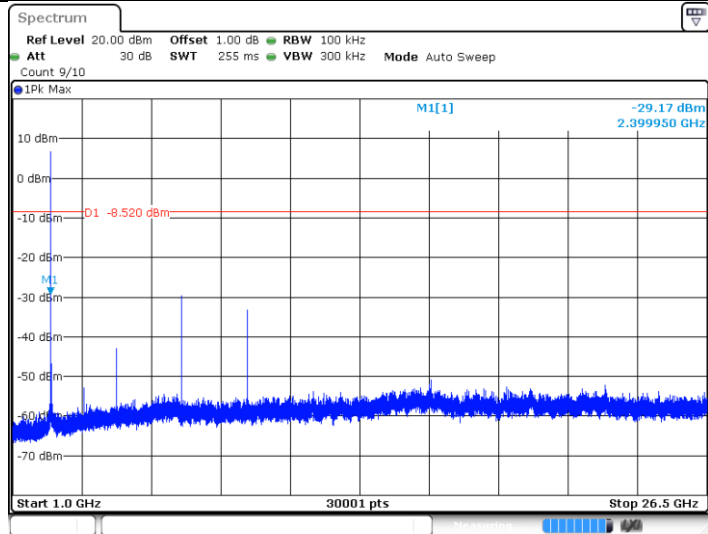

Date: 11.MAY.2021 19:23:21

2DH5\_Ant1\_2441\_0~Reference

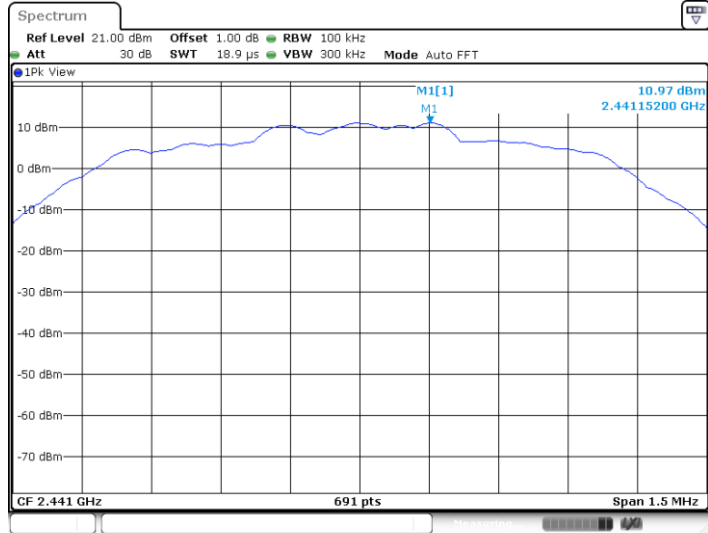

Date: 11.MAY.2021 19:25:11

2DH5\_Ant1\_2441\_30~1000

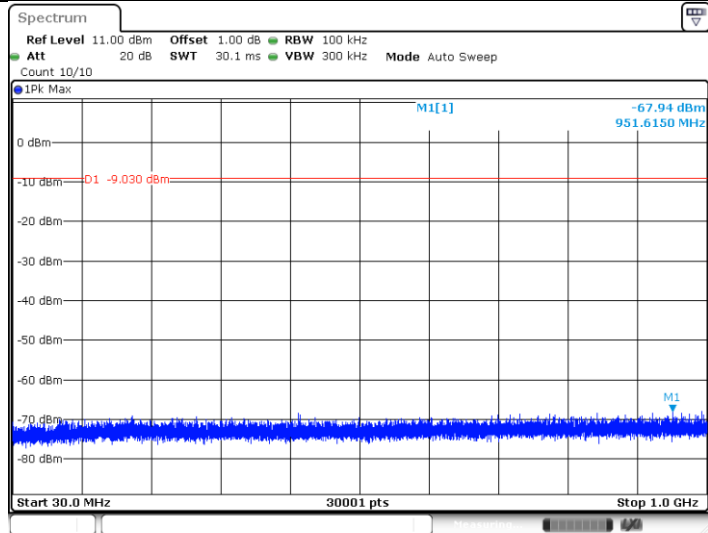

Date: 11.MAY.2021 19:25:17

2DH5\_Ant1\_2441\_1000~26500

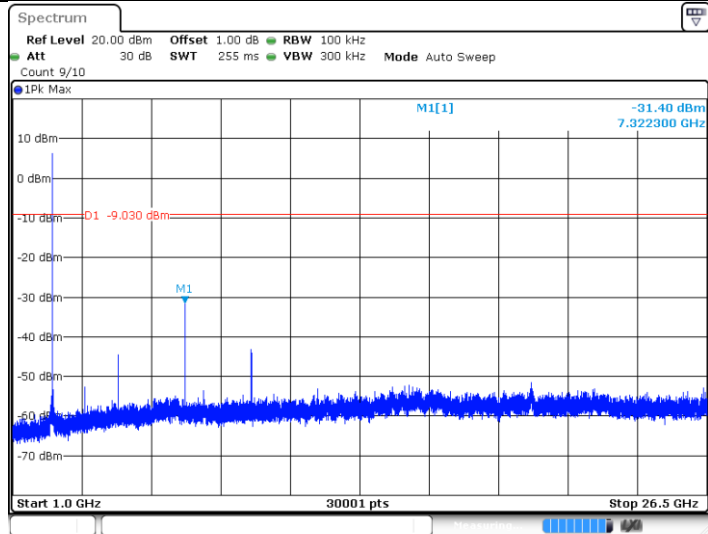

Date: 11.MAY.2021 19:25:25

2DH5\_Ant1\_2480\_0~Reference

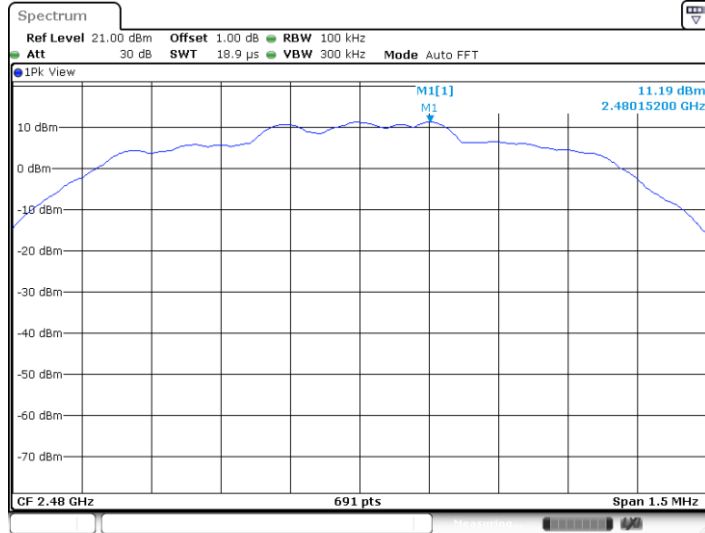

Date: 11.MAY.2021 19:27:37

2DH5\_Ant1\_2480\_30~1000

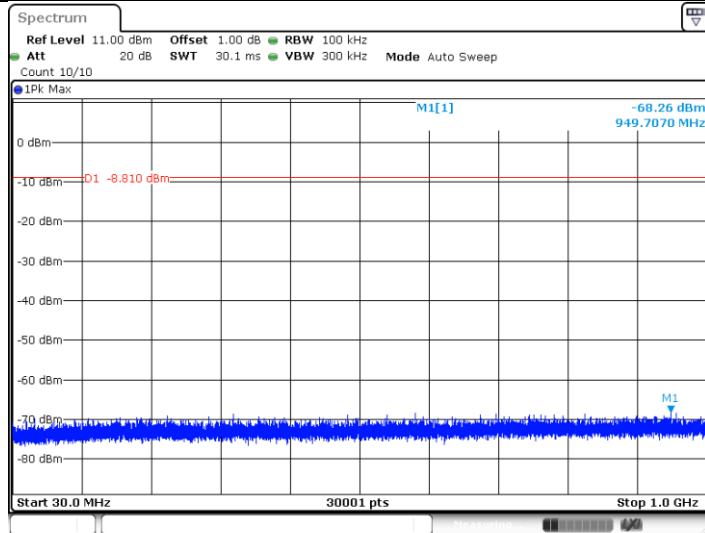

Date: 11.MAY.2021 19:27:43

2DH5\_Ant1\_2480\_1000~26500

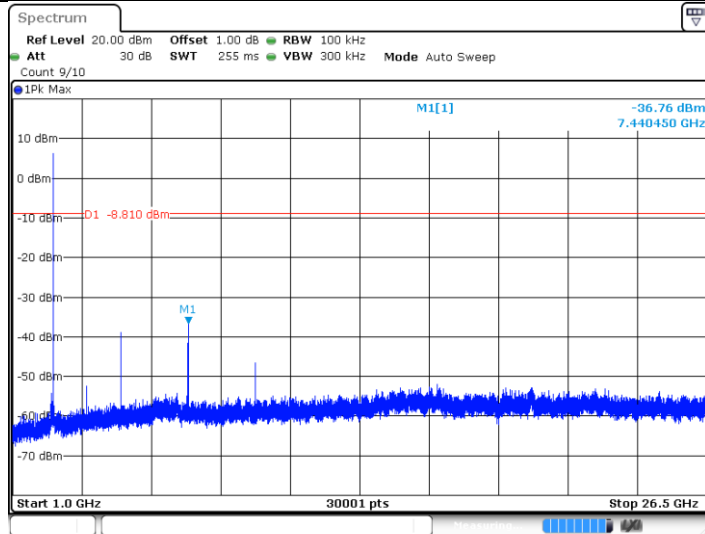

Date: 11.MAY.2021 19:27:51

3DH5\_Ant1\_2402\_0~Reference

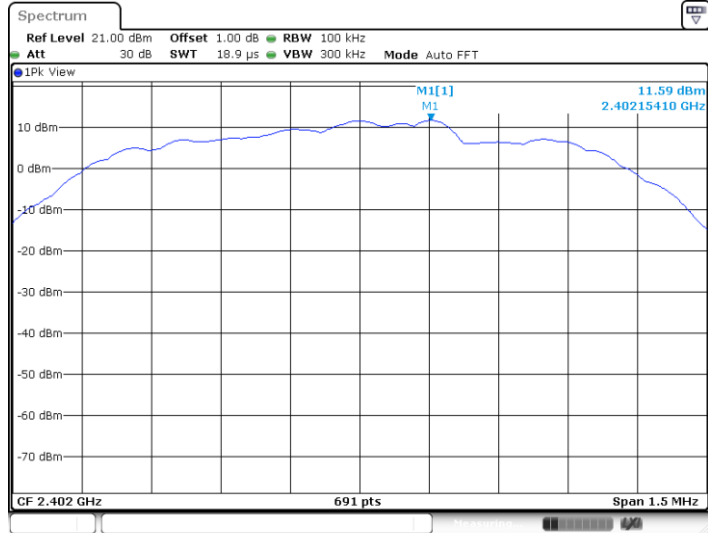

Date: 11.MAY.2021 19:29:29

3DH5\_Ant1\_2402\_30~1000

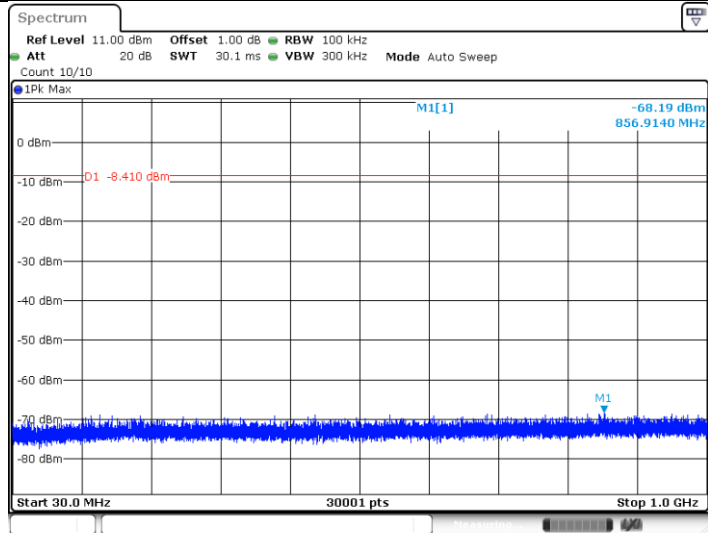

Date: 11.MAY.2021 19:29:35

3DH5\_Ant1\_2402\_1000~26500

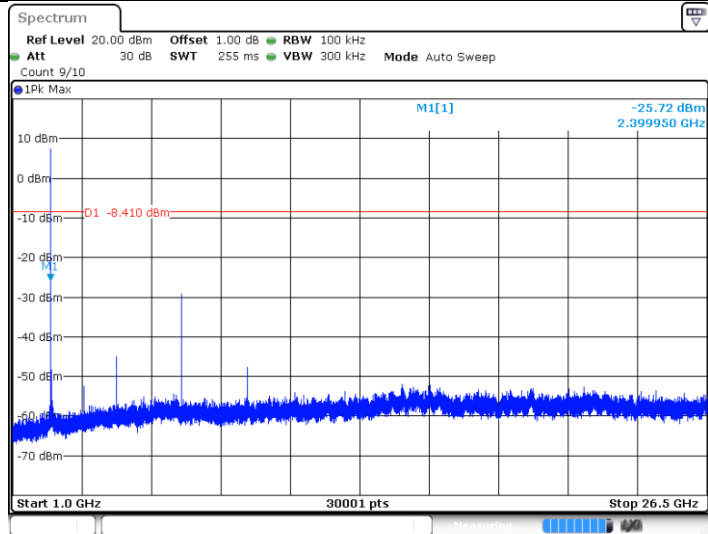

Date: 11.MAY.2021 19:29:43

3DH5\_Ant1\_2441\_0~Reference

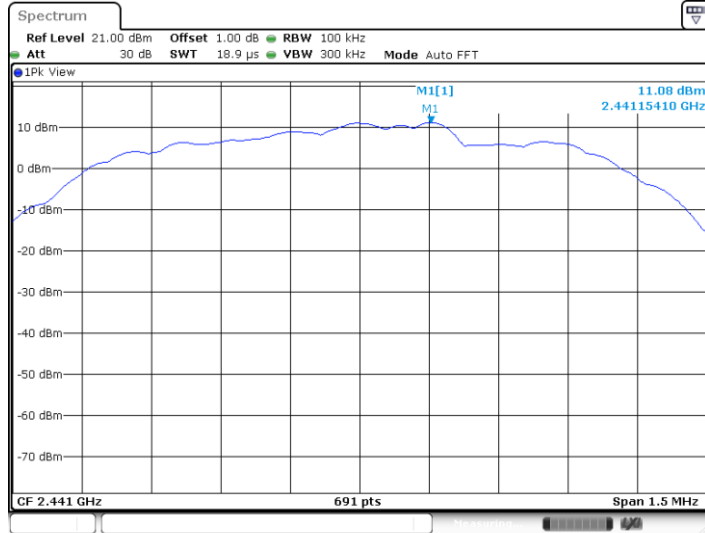

Date: 11.MAY.2021 19:31:08

3DH5\_Ant1\_2441\_30~1000

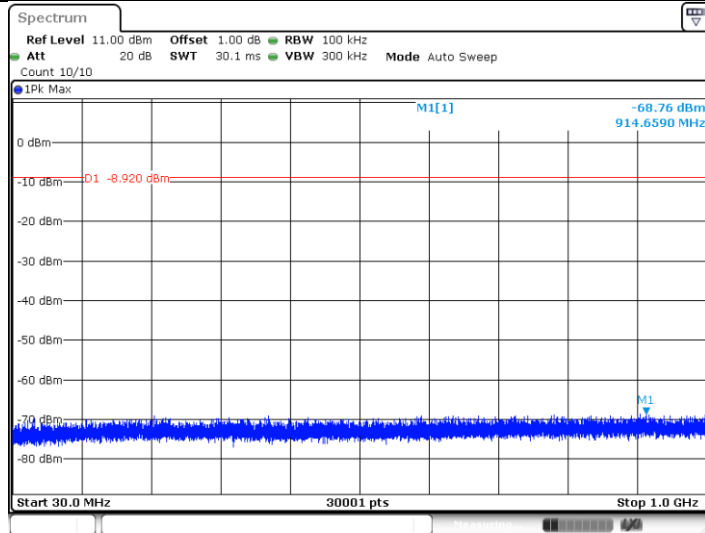

Date: 11.MAY.2021 19:31:14

3DH5\_Ant1\_2441\_1000~26500

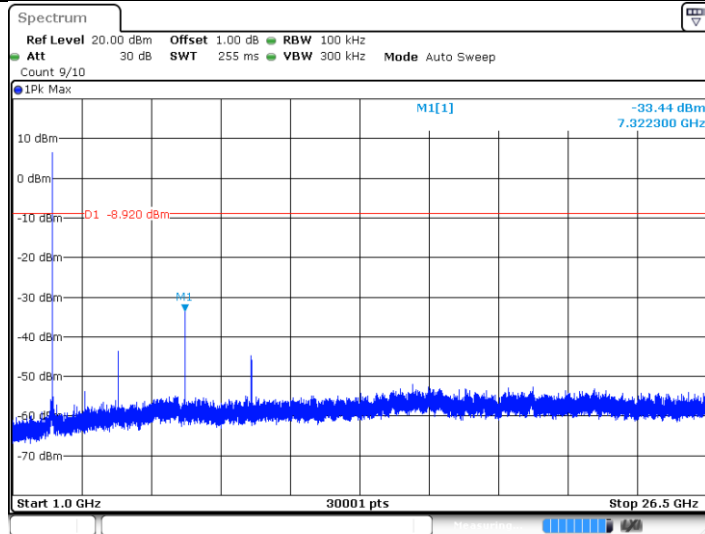

Date: 11.MAY.2021 19:31:22

3DH5\_Ant1\_2480\_0~Reference

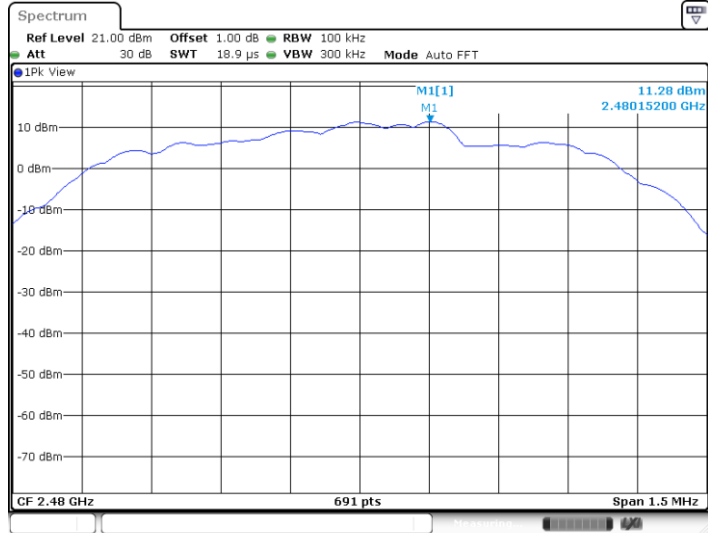

Date: 11.MAY.2021 19:33:51

3DH5\_Ant1\_2480\_30~1000

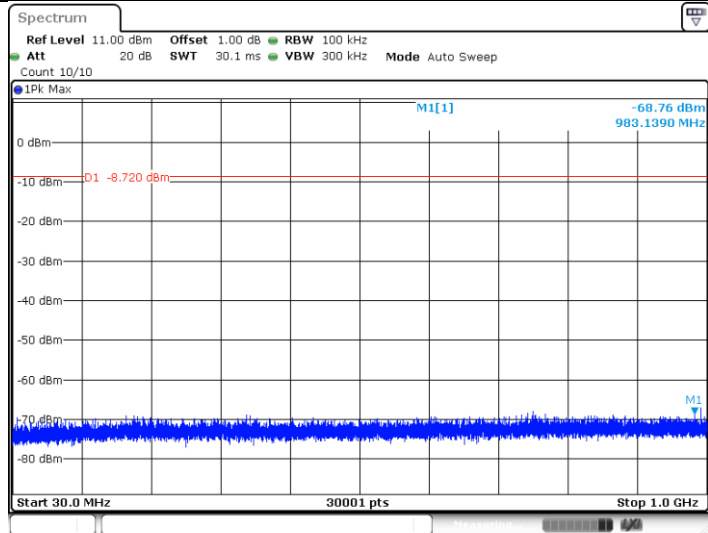

Date: 11.MAY.2021 19:33:57

3DH5\_Ant1\_2480\_1000~26500

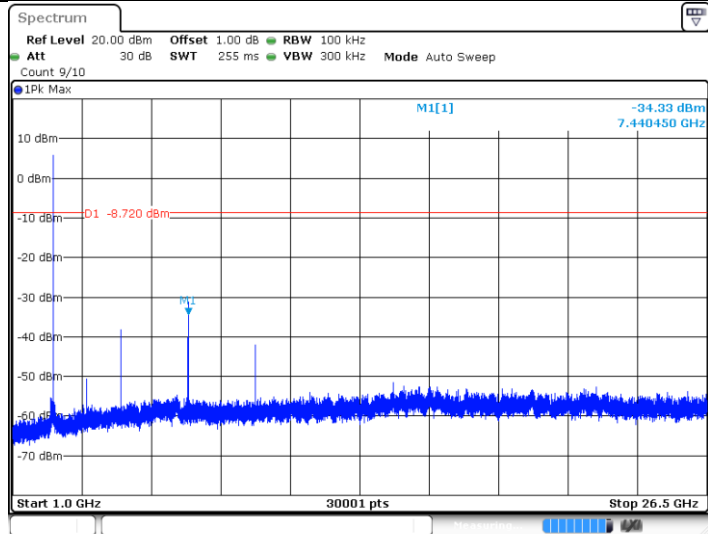

Date: 11.MAY.2021 19:34:05

## 9.7 Band edge testing

### Test Method

- 1 Use the following spectrum analyzer settings:  
Span = wide enough to capture the peak level of the in-band emission and all spurious  
RBW = 100 kHz, VBW  $\geq$  RBW, Sweep = auto, Detector function = peak, Trace = max hold
- 2 Allow the trace to stabilize, use the peak and delta measurement to record the result.
- 3 The level displayed must comply with the limit specified in this Section. .
- 4 Repeat the test at the hopping off and hopping on mode, submit all the plots.

### Limit:

In any 100 kHz bandwidth outside the frequency band in which the spread spectrum or digitally modulated device is operating, the RF power that is produced shall be at least 20 dB below that in the 100 kHz bandwidth within the band that contains the highest level of the desired power, based on either an RF conducted or a radiated measurement, provided that the transmitter demonstrates compliance with the peak conducted power limits.

DH5\_Ant1\_Low\_2402

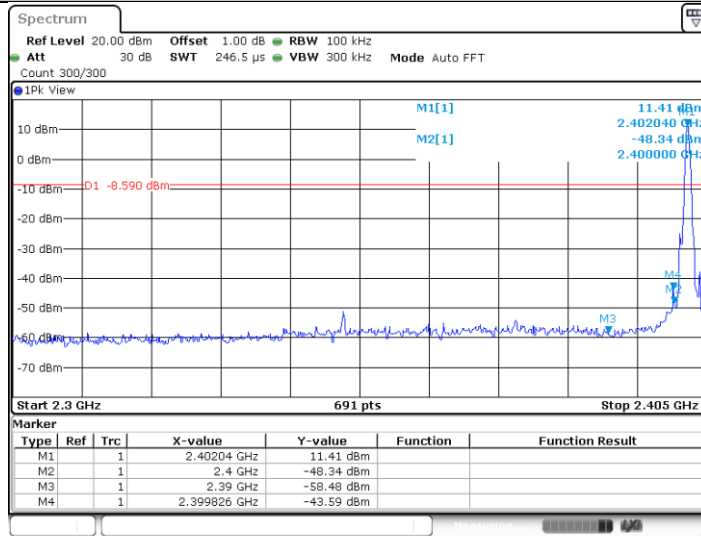

Date: 11.MAY.2021 19:13:47

DH5\_Ant1\_High\_2480

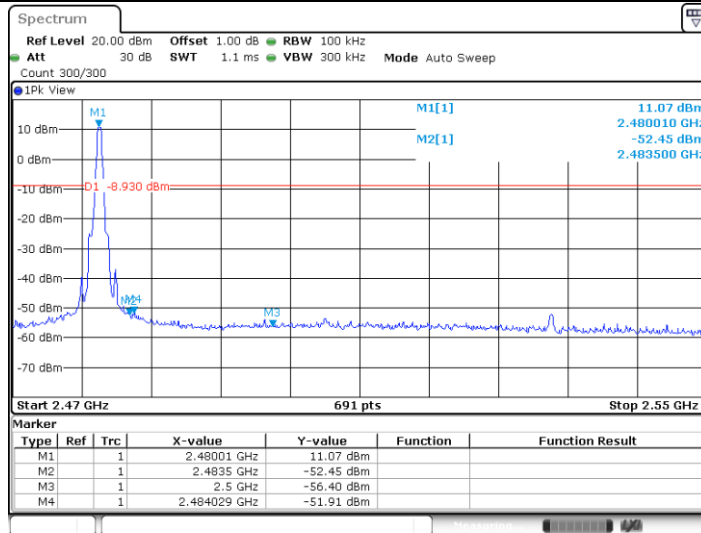

Date: 11.MAY.2021 19:20:55

DH5\_Ant1\_Low\_Hop\_2402

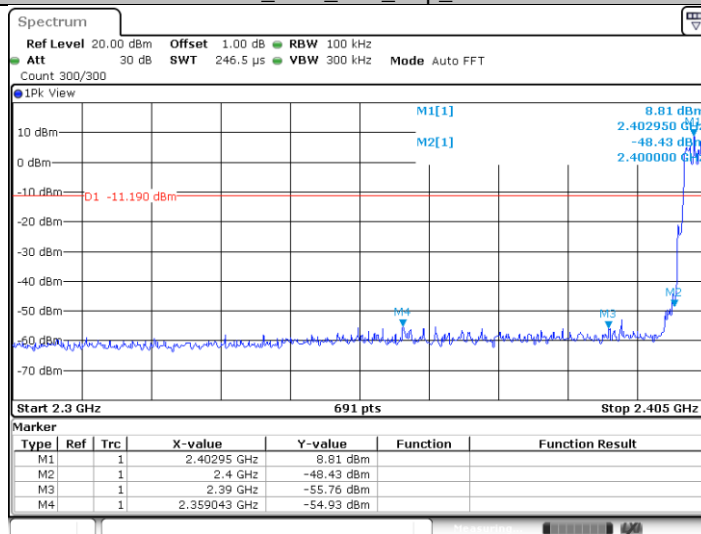

Date: 11.MAY.2021 19:34:56



DH5\_Ant1\_High\_Hop\_2480

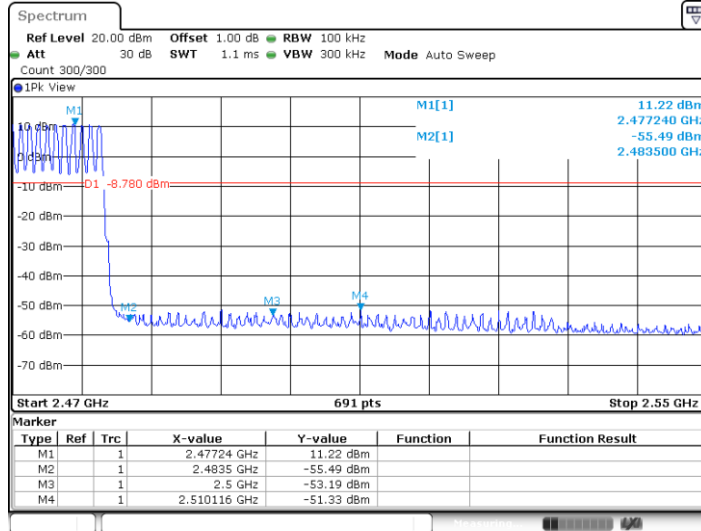

Date: 11.MAY.2021 19:38:19

2DH5\_Ant1\_Low\_2402

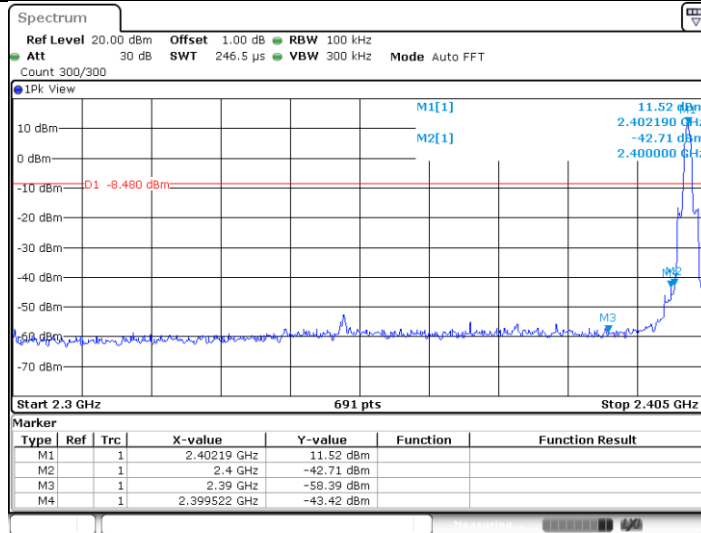

Date: 11.MAY.2021 19:23:02

2DH5\_Ant1\_High\_2480

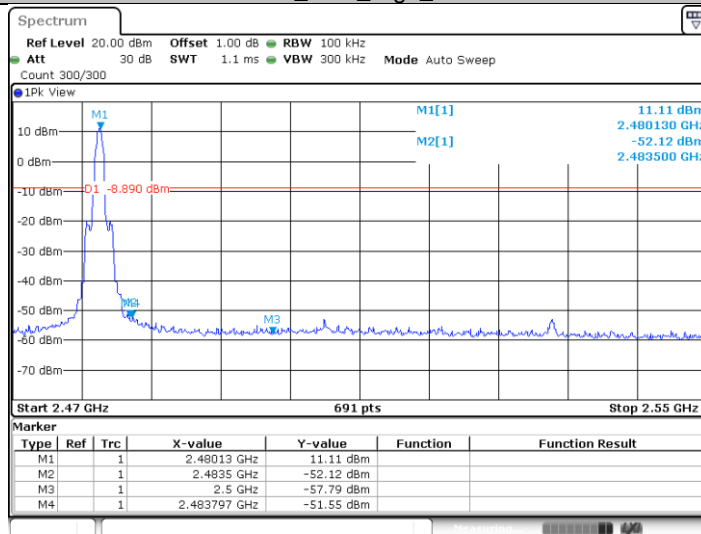

Date: 11.MAY.2021 19:27:31



2DH5\_Ant1\_Low\_Hop\_2402

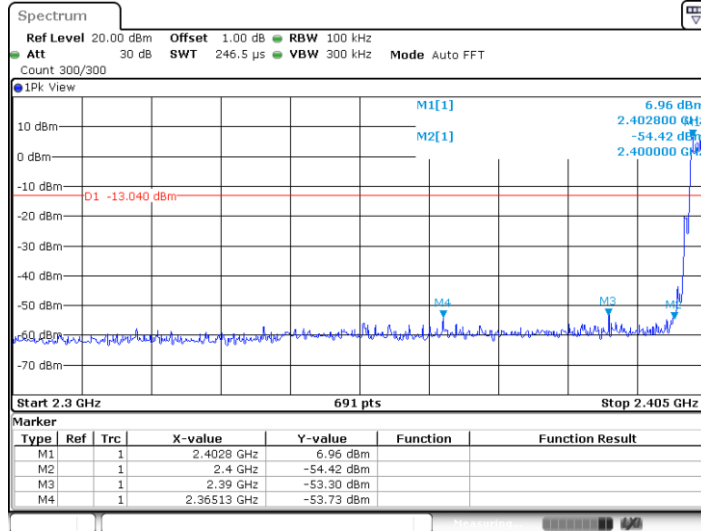

Date: 11.MAY.2021 19:55:35

2DH5\_Ant1\_High\_Hop\_2480

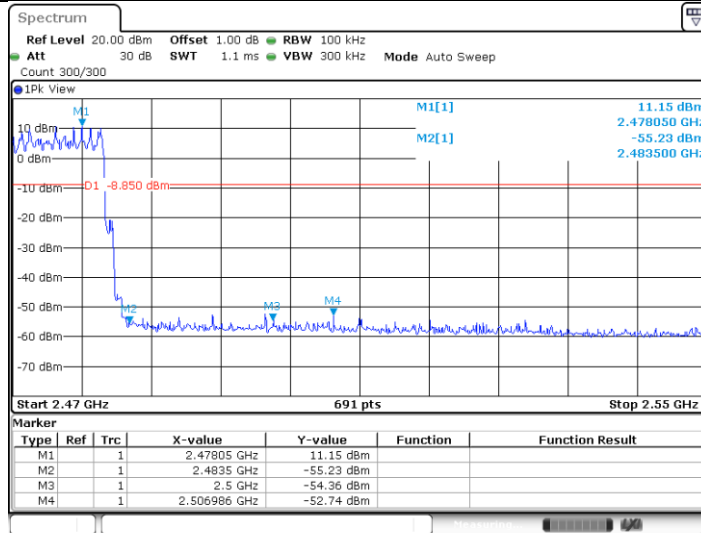

Date: 11.MAY.2021 19:59:30

3DH5\_Ant1\_Low\_2402

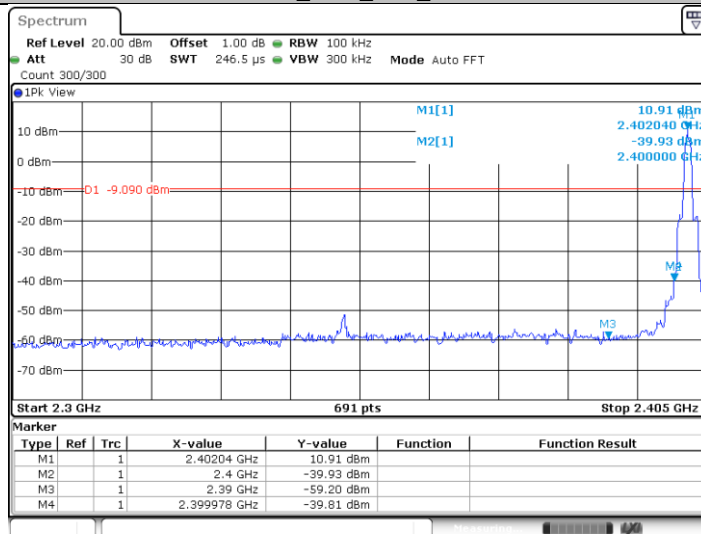

Date: 11.MAY.2021 19:29:24

### 3DH5\_Ant1\_High\_2480

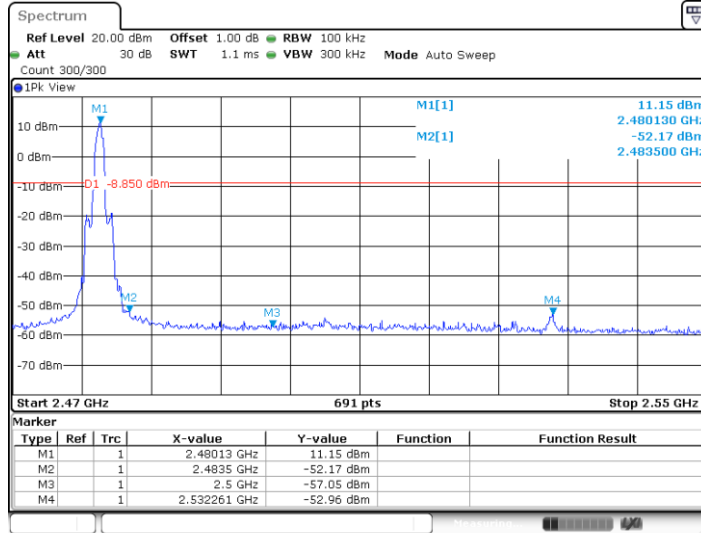

Date: 11.MAY.2021 19:33:45

### 3DH5\_Ant1\_Low\_Hop\_2402

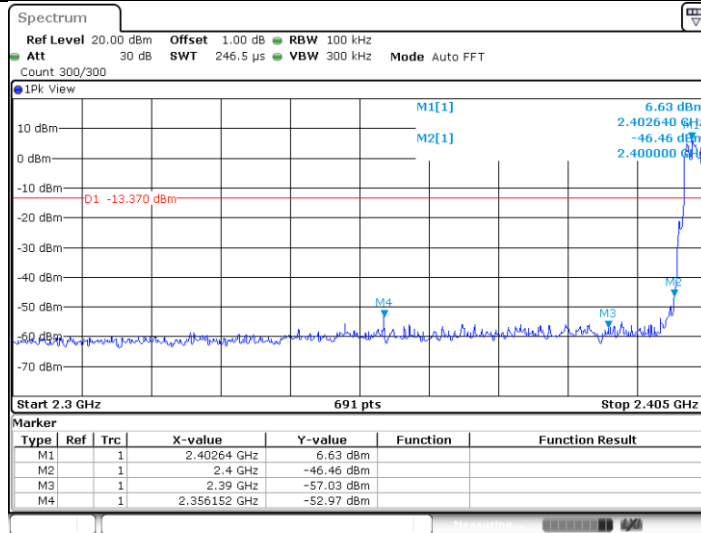

Date: 11.MAY.2021 20:00:08

### 3DH5\_Ant1\_High\_Hop\_2480

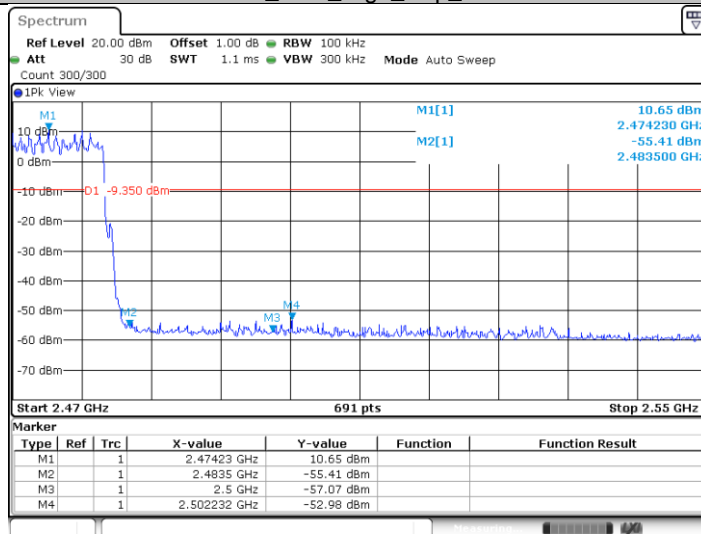

Date: 11.MAY.2021 20:03:53

## 9.8 Spurious radiated emissions for transmitter

### Test Method

- 1: The EUT was placed on a turn table which is 1.5m above ground plane for above 1GHz and 0.8m above ground for below 1GHz at 3 meter chamber room for test. The table was rotated 360 degrees to determine the position of the highest radiation.
- 2: The EUT was set 3 meters away from the interference – receiving antenna, which was mounted on the top of a variable – height antenna tower.
- 3: The height of antenna is varied from one meter to four meters above the ground to determine the maximum value of the field strength. Both horizontal and vertical polarizations of the antenna are set to make the measurement.
- 4: For each suspected emission, the EUT was arranged to its worst case and then the antenna was tuned to heights from 1 meter to 4 meters and the rotatable table was turned from 0 degrees to 360 degrees to find the maximum reading.
- 5: Use the following spectrum analyzer settings According to C63.10:

For Below 1GHz

Use the following spectrum analyzer settings:

Span = wide enough to capture the peak level of the in-band emission and all spurious  
RBW = 100 KHz to 120KHz, VBW $\geq$ RBW for peak measurement, Sweep = auto,  
Detector function = peak, Trace = max hold.

For Peak unwanted emissions Above 1GHz:

Span = wide enough to capture the peak level of the in-band emission and all spurious  
RBW = 1MHz, VBW $\geq$ RBW for peak measurement, Sweep = auto,  
Detector function = peak, Trace = max hold.

Procedures for average unwanted emissions measurements above 1000 MHz:

Span = wide enough to capture the peak level of the in-band emission and all spurious  
RBW = 1MHz, VBW=10Hz, Sweep = auto, Detector function = peak, Trace = max hold.  
If the dwell time per channel of the hopping signal is less than 100 ms, then the reading obtained with the 10 Hz VBW may be further adjusted by a “duty cycle correction factor”, derived from  $20\log(\text{dwell time}/100 \text{ ms})$ , in an effort to demonstrate compliance with the 15.209 limit.

If the emission is pulsed, modify the unit for continuous operation; use the settings shown above, then correct the reading by subtracting the peak-average correction factor, derived from the appropriate duty cycle calculation.

The setting method can refer to DA00-705.

## Limit

The radio emission outside the operating frequency band shall be at least 20 dB below that in the 100 kHz bandwidth within the band that contains the highest level of the desired power. Radiated emissions which fall in the restricted bands, as defined in section 15.205, must comply with the radiated emission limits specified in section 15.209.

In any 100 kHz bandwidth outside the frequency band in which the spread spectrum or digitally modulated device is operating, the RF power that is produced shall be at least 20 dB below that in the 100 kHz bandwidth within the band that contains the highest level of the desired power, based on either an RF conducted or a radiated measurement, provided that the transmitter demonstrates compliance with the peak conducted power limits. If the transmitter complies with the conducted power limits based on the use of root-mean-square averaging over a time interval, as permitted under section 5.4(d), the attenuation required shall be 30 dB instead of 20 dB. Attenuation below the general field strength limits specified in RSS-Gen is not required.

Frequency MHz	Field Strength uV/m	Field Strength dBµV/m	Detector
30-88	100	40	QP
88-216	150	43.5	QP
216-960	200	46	QP
960-1000	500	54	QP
Above 1000	500	54	AV
Above 1000	5000	74	PK

## Spurious radiated emissions for transmitter

According to C63.10, if the peak (or quasi-peak) measured value complies with the average limit, it is unnecessary to perform an average measurement, so AV emission value did not show in below table if the peak value complies with average limit.

The only worse case (GFSK mode) test result is listed in the report.

### Transmitting spurious emission test result as below:

Below 1G:

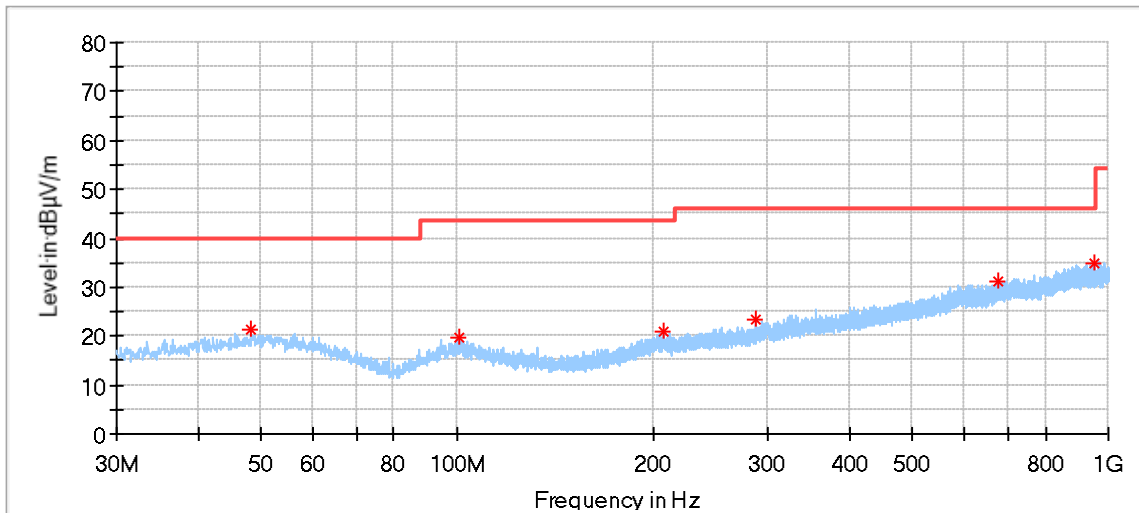

Frequency (MHz)	MaxPeak (dBµV/m)	Limit (dBµV/m)	Margin (dB)	Height (cm)	Pol	Azimuth (deg)	Corr. (dB/m)
48.106667	21.21	40.00	18.79	200.0	H	346.0	14.96
100.863889	19.77	43.50	23.73	200.0	H	289.0	12.70
206.863333	21.11	43.50	22.39	200.0	H	191.0	12.70
287.535000	23.25	46.00	22.75	200.0	H	42.0	14.58
677.313333	31.29	46.00	14.71	200.0	H	303.0	22.15
948.590000	35.01	46.00	10.99	200.0	H	241.0	25.54

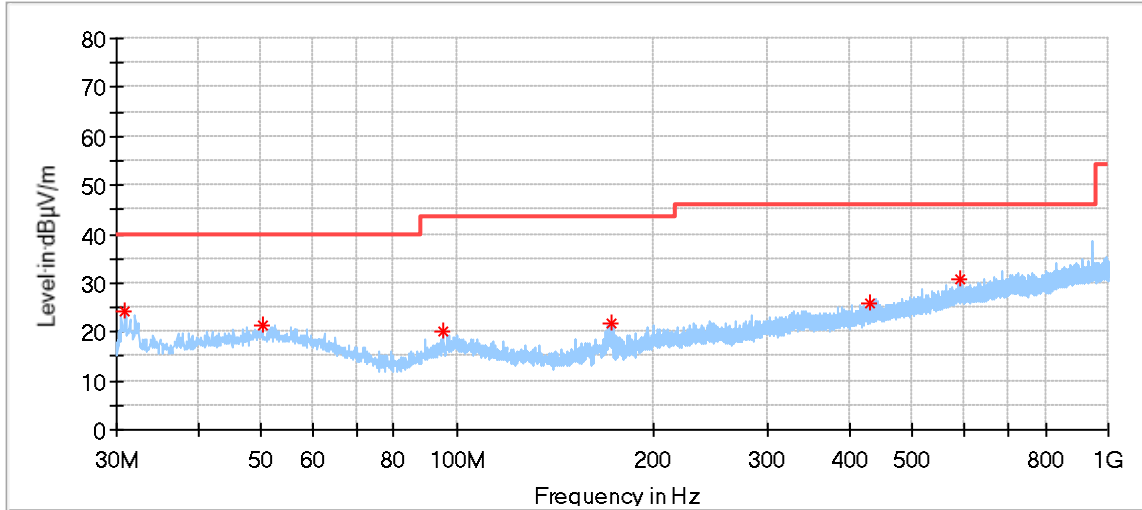

Frequency (MHz)	MaxPeak (dBµV/m)	Limit (dBµV/m)	Margin (dB)	Height (cm)	Pol	Azimuth (deg)	Corr. (dB/m)
30.970000	24.02	40.00	15.98	100.0	V	203.0	11.32
50.262222	21.20	40.00	18.80	100.0	V	64.0	15.23
95.367222	20.08	43.50	23.42	100.0	V	144.0	11.90
172.212778	21.72	43.50	21.78	100.0	V	286.0	10.33
431.202778	25.94	46.00	20.06	100.0	V	231.0	17.97
590.929444	30.62	46.00	15.38	100.0	V	1.0	21.04

Low channel 2402MHz

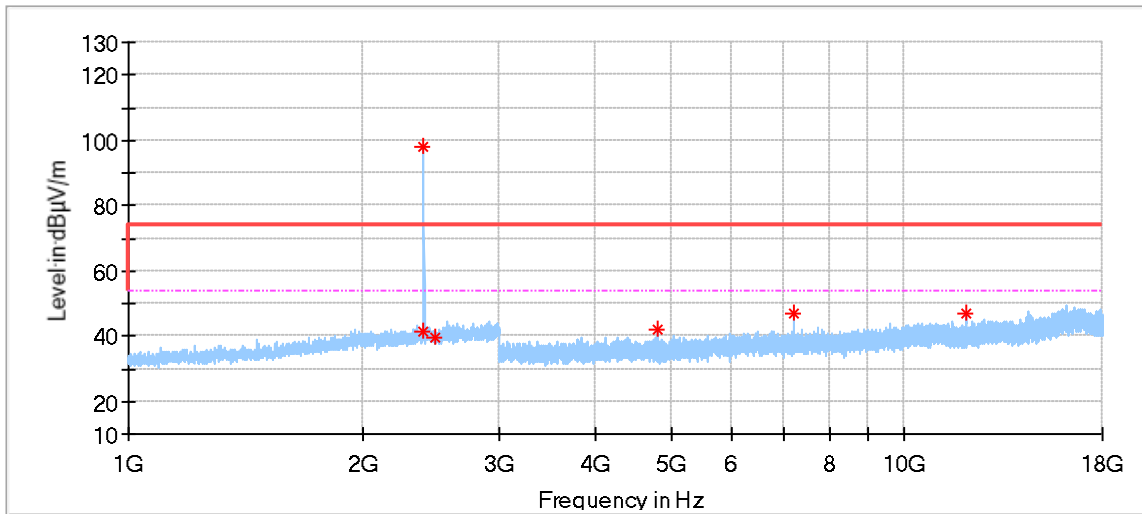

Frequency (MHz)	MaxPeak (dBµV/m)	Limit (dBµV/m)	Margin (dB)	Height (cm)	Pol	Azimuth (deg)	Corr. (dB/m)
2390.571429	41.34	74.00	32.66	150.0	H	266.0	-2.99
2402.380952	98.24	74.00	-24.24	150.0	H	279.0	-2.99
2483.809524	39.49	74.00	34.51	150.0	H	147.0	-2.69
4804.000000	42.01	74.00	31.99	150.0	H	353.0	2.18
7205.500000	46.89	74.00	27.11	150.0	H	158.0	6.80
12011.000000	46.75	74.00	27.25	150.0	H	308.0	10.30

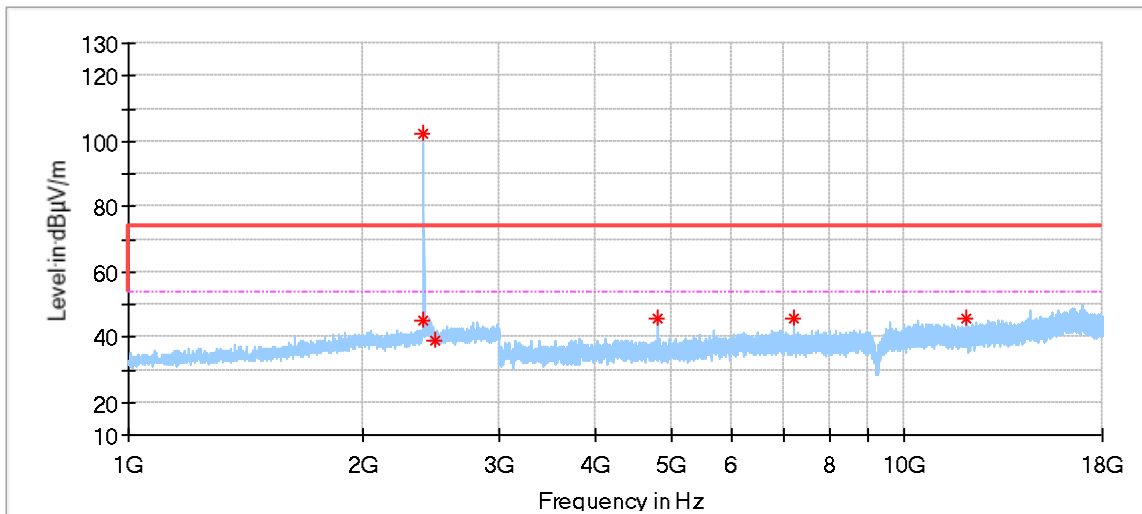

Frequency (MHz)	MaxPeak (dBµV/m)	Limit (dBµV/m)	Margin (dB)	Height (cm)	Pol	Azimuth (deg)	Corr. (dB/m)
2390.095238	44.77	74.00	29.23	150.0	V	207.0	-2.98
2402.380952	102.06	74.00	-28.06	150.0	V	141.0	-2.99
2483.809524	39.14	74.00	34.86	150.0	V	48.0	-2.69
4804.000000	45.56	74.00	28.44	150.0	V	137.0	2.18
7205.500000	45.79	74.00	28.21	150.0	V	185.0	6.80
12009.500000	45.50	74.00	28.50	150.0	V	61.0	10.29



Middle channel 2441MHz

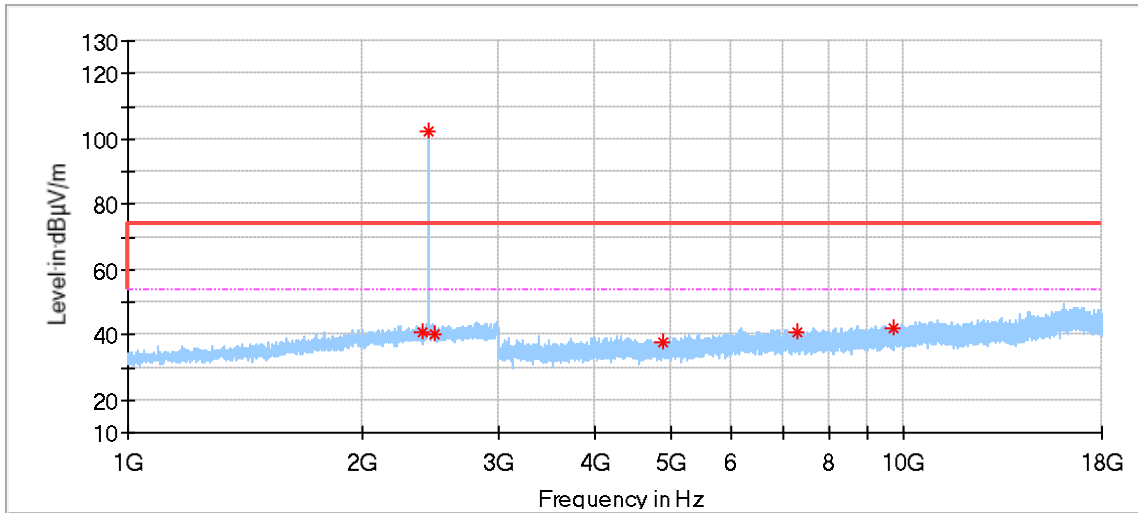

Frequency (MHz)	MaxPeak (dBµV/m)	Limit (dBµV/m)	Margin (dB)	Height (cm)	Pol	Azimuth (deg)	Corr. (dB/m)
2390.056955	40.97	74.00	33.03	150.0	H	89.0	-2.99
2441.428571	102.13	74.00	-28.13	150.0	H	63.0	-2.90
2483.809524	40.10	74.00	33.90	150.0	H	8.0	-2.69
4882.500000	37.44	74.00	36.56	150.0	H	356.0	2.37
7309.000000	40.81	74.00	33.19	150.0	H	329.0	7.03
9708.000000	42.28	74.00	31.72	150.0	H	226.0	9.47

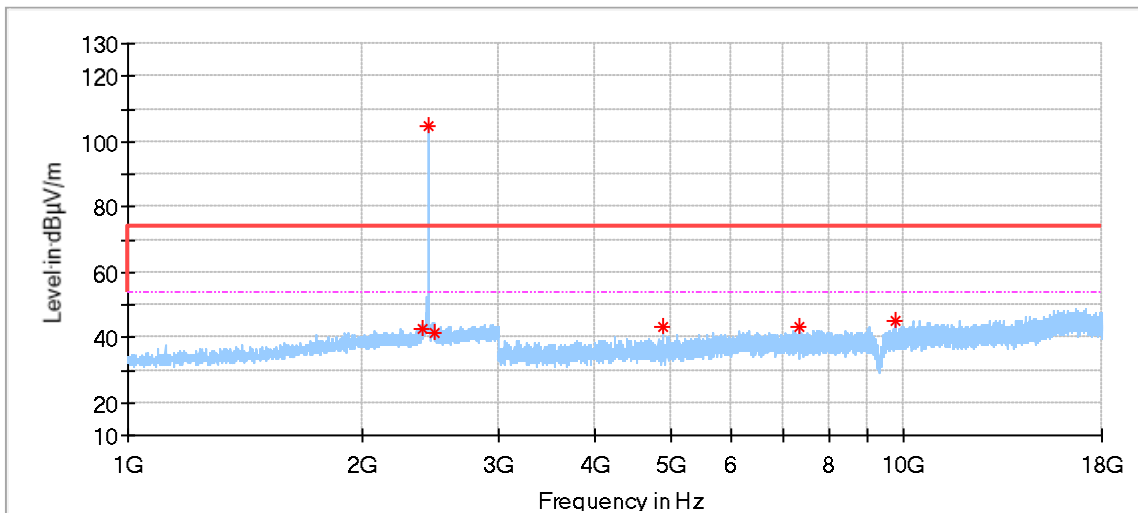

Frequency (MHz)	MaxPeak (dBµV/m)	Limit (dBµV/m)	Margin (dB)	Height (cm)	Pol	Azimuth (deg)	Corr. (dB/m)
2390.000000	42.56	74.00	31.44	150.0	V	8.0	-2.99
2441.428571	104.82	74.00	-30.82	150.0	V	128.0	-2.90
2483.809524	41.28	74.00	32.72	150.0	V	188.0	-2.69
4882.000000	43.43	74.00	30.57	150.0	V	329.0	2.37
7322.500000	43.22	74.00	30.78	150.0	V	329.0	7.05
9763.500000	44.87	74.00	29.13	150.0	V	153.0	9.70

High channel 2480MHz

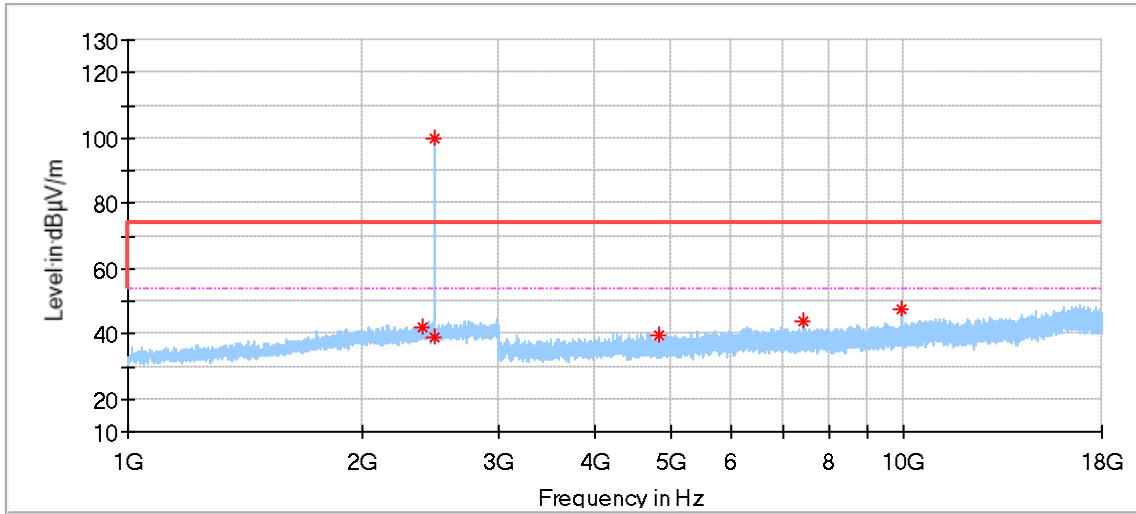

Frequency (MHz)	MaxPeak (dBµV/m)	Limit (dBµV/m)	Margin (dB)	Height (cm)	Pol	Azimuth (deg)	Corr. (dB/m)
2390.523810	42.06	74.00	31.94	150.0	H	31.0	-2.99
2480.476191	99.88	74.00	-25.88	150.0	H	88.0	-2.69
2483.809524	39.00	74.00	35.00	150.0	H	206.0	-2.69
4840.000000	39.53	74.00	34.47	150.0	H	356.0	2.30
7440.000000	43.55	74.00	30.45	150.0	H	176.0	7.22
9920.000000	47.73	74.00	26.27	150.0	H	103.0	9.56

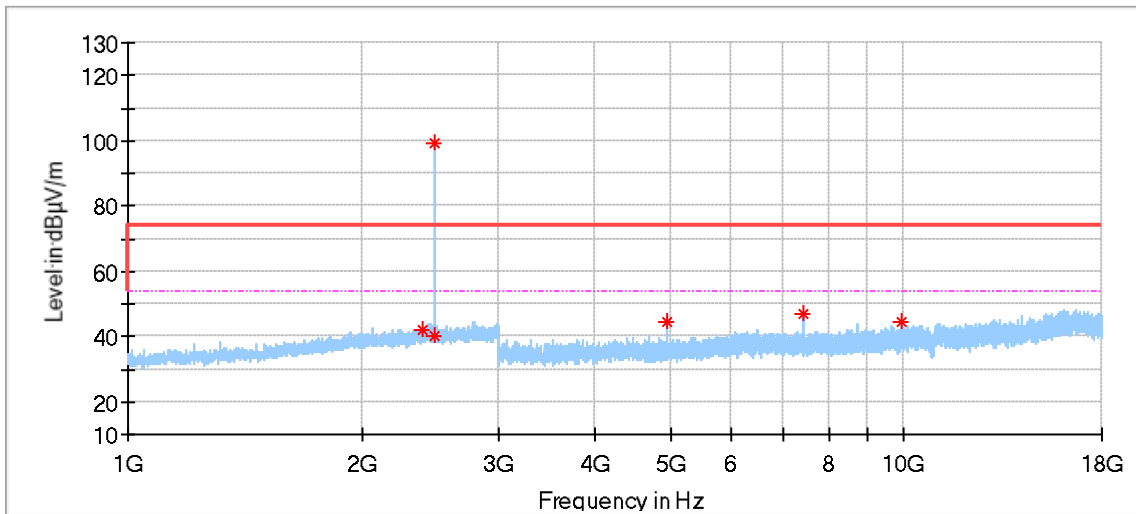

Frequency (MHz)	MaxPeak (dBµV/m)	Limit (dBµV/m)	Margin (dB)	Height (cm)	Pol	Azimuth (deg)	Corr. (dB/m)
2390.666667	42.16	74.00	31.84	150.0	V	327.0	-2.98
2480.476191	99.44	74.00	-25.44	150.0	V	256.0	-2.69
2483.809524	39.90	74.00	34.10	150.0	V	263.0	-2.69
4960.500000	44.17	74.00	29.83	150.0	V	8.0	2.55
7440.500000	47.08	74.00	26.92	150.0	V	55.0	7.22
9920.500000	44.77	74.00	29.23	150.0	V	226.0	9.56

Remark:

- (1) Data of measurement within frequency range 18-26GHz are the noise floor or attenuated more than 20dB below the permissible limits or the field strength is too small to be measured, so test data does not present in this report

- (2) Frequencies which exceed the limit are carrier frequency.
- (3) Level= Reading Level + Correction Factor
- (4) Above 1GHz: Corrector factor = Antenna Factor + Cable Loss- Amplifier Gain  
Below 1GHz: Corrector factor = Antenna Factor + Cable Loss  
(The Reading Level is recorded by software which is not shown in the sheet)

## 10 Test Equipment List

### Radiated Emission Test

Description	Manufacturer	Model no.	Equipment ID	Serial no.	cal interval (year)	cal. due date
EMI Test Receiver	Rohde & Schwarz	ESR 26	68-4-74-14-002	101269	1	2021-6-29
Trilog Super Broadband Test Antenna	Schwarzbeck	VULB 9162	68-4-80-19-003	284	1	2021-2-24
Wave Guide Antenna	ETS	3117	68-4-80-19-001	00218954	1	2021-6-15
Pre-amplifier	Rohde & Schwarz	SCU 18F	68-4-29-19-001	100745	1	2021-12-14
Pre-amplifier	Rohde & Schwarz	SCU 08F2	68-4-29-19-004	08400018	1	2021-12-14
Sideband Horn Antenna	Q-PAR	QWH-SL-18-40-K-SG	68-4-80-14-008	12827	1	2021-8-5
Pre-amplifier	Rohde & Schwarz	SCU 40A	68-4-29-14-002	100432	1	2021-7-30
3m Semi-anechoic chamber	TDK	9X6X6	68-4-90-19-006	----	3	2022-12-29
Test software	Rohde & Schwarz	EMC32	68-4-90-19-006-A01	Version10.35.02	N/A	N/A

### RF Conducted Test

Description	Manufacturer	Model no.	Equipment ID	Serial no.	cal interval (year)	cal. due date
Signal Analyzer	Rohde & Schwarz	FSV40	68-4-74-14-004	101030	1	2021-6-21

## 11 System Measurement Uncertainty

For a 95% confidence level, the measurement expanded uncertainties for defined systems, in accordance with the recommendations of ISO 17025 were:

System Measurement Uncertainty	
Test Items	Extended Uncertainty
Uncertainty for Conducted Emission 150kHz-30MHz (for test using AMN ENV432 or ENV4200)	3.62dB
Uncertainty for Radiated Emission 25MHz-3000MHz	Horizontal: 4.63dB; Vertical: 4.61dB;
Uncertainty for Radiated Emission 3000MHz- 18000MHz	Horizontal: 4.65dB; Vertical: 4.64dB;
Uncertainty for Radiated Emission 18000MHz- 40000MHz	Horizontal: 4.89dB; Vertical: 4.87dB;
Uncertainty for Conducted RF test	RF Power Conducted: 1.16dB Frequency test involved: $0.6 \times 10^{-7}$ or 1%

---THE END OF REPORT---