

FJDynamics Autosteering Kit

Hardware Installation Instruction



FJ Dynamics Technology Co., Ltd.

Aug 2020

Disclaimer

- ◆ The products, service or features that you have purchased are subject to commercial contracts and terms. Some products, service or features mentioned in this Instruction may not be within the range of purchasing or application. Unless otherwise specified in the contract, FJ Dynamics Technology Co., Ltd. (hereinafter referred to as FJ Dynamics) makes no express or implied statement about the content of this Instruction.
- ◆ This Instruction may be updated due to product upgrading or other reasons, and FJ Dynamics reserves the right to modify this document without notice.
- ◆ This Instruction is for reference only. FJ Dynamics has made all possible efforts for the accuracy and reliability of the information contained in this Instruction, but errors or omissions may be inevitable. All information in this Instruction does not constitute any express or implied warranty.

Foreword

Thanks for choosing products of FJDynamics. This Instruction provides detailed hardware installation instructions. If you have any problems during use, please contact local dealers.

Notes:

1. This device complies with part 15 of the FCC Rules. Operation is subject to the following two conditions:
 - (1).This device may not cause harmful interference,and
 - (2).This device must accept any interference received,including interference that may cause undesired operation.
2. This device complies with Innovation, Science and Economic Development Canada licence-exempt RSS standard(s). Operation is subject to the following two conditions:
 - (1) This device may not cause interference, and
 - (2) This device must accept any interference received, including interference that may cause undesired operation.

Technical support

Official website: <https://www.fjdynamics.com/>

Table of Contents

1. Introduction	1
2. Preparations	1
2.1 Safety Requirement.....	1
Electrical safety	1
2.2 Installation site requirements	2
2.3 Installation tools.....	3
2.4 Unpacking and inspection	4
3. Installation	6
3.1 Check before installation.....	6
3.2 Installation process.....	8
3.3 Precautions during installation.....	9
4. Installation steps	9
4.1 Installation of electrical steering wheel	9
4.1.1 Materials required for installation of electrical steering wheel.....	9
4.1.2 Installation steps of electrical steering wheel.....	11
4.2 Installation of angle sensor	14
4.2.1 Materials required for installation of angle sensor.....	14
4.2.2 Installation steps of angle sensor.....	15
4.3 Installation of antenna	18
4.3.1 Materials required for installation of antenna.....	18
4.3.2 Installation steps of antenna.....	19
4.4 Installation of IMU.....	23
4.4.1 Materials required for installation of IMU	23
4.4.2 Installation steps of IMU	23
4.5 Installation of control terminal.....	24
4.5.1 Materials required for installation control terminal	24
4.5.2 Installation steps of control terminal.....	25
4.6 Installation of cable harness.....	27
4.6.1 Materials required for installation of cable harness	27
4.6.2 Installation steps of cable harness	28
4.7 Installation of SIM card	29
4.7.1 Materials required for installation of SIM card.....	29
4.7.2 Installation of SIM card	30
5. System debugging	30

5.1 Debugging site requirements	30
5.2 Power-on and Startup	31
5.2.1 Inspection before power-on	31
5.2.2 Inspection after power-on	31
5.3 Parameter Calibration	31
6. Appendix	32
6.1 Main hardware and its specifications.....	32

1. Introduction

The FJDynamics autosteering kit for agricultural machinery, launched by FJDynamics, supports assisted straight-line driving and front-mounted fully unmanned transformation. The system can not only control the steering to realize the assisted driving of the vehicle, but also realize the fully unmanned transformation of agricultural machinery through the control of the vehicle's accelerator, brake, clutch, transmission, and operation unit. The system is composed of data communication equipment, in-vehicle display and control terminal, BeiDou high-precision positioning equipment, steering motor, angle sensor, attitude sensor, communication antenna, wiring harness, etc. Among them, the in-vehicle display and control terminal is equipped with autosteering software independently developed by FJDynamics.

2. Preparations

2.1 Safety Requirement

To avoid personal injury and equipment damage, please read the safety recommendations herein carefully before installation. The following safety recommendation does not cover all possible hazardous conditions.

Installation safety

- ◆ Do not install the product or perform debugging in the environment with high temperature, heavy dust, harmful gas, inflammable substances, explosive substances, electromagnetic interference (large radar station, transmitter station, substation), unstable voltage, high vibration or loud noise; otherwise, the equipment may be unable to operate normally.
- ◆ Do not install the equipment in places vulnerable to water accumulation, water seepage, water dripping, condensation, etc., so as to prevent the equipment from being damaged by water accumulated at the interface.

Removal safety

- ◆ After the equipment has been installed, do not remove it frequently for fear of unexpected damage.
- ◆ Before removal, please turn off all the power supplies and remove the battery cable to prevent damage to the equipment due to live operation.

Electrical safety

- ◆ Carry out electrical operations in accordance with local regulations and specifications by qualified electricians.
- ◆ Please carefully check the working area for potential hazards, such as wet floor.
- ◆ Before installation, identify the location of the emergency power switch. In case of an accident,

disconnect the power switch.

- ◆ Always make inspections carefully when it is necessary to turn off the power supply.
- ◆ Do not place the equipment in a humid place, and keep it away from liquids.
- ◆ Keep it away from high power wireless equipment such as wireless transmitter, radar transmitter, high frequency and current devices, microwave oven.
- ◆ Prevent direct or indirect contact with high voltage power supply or mains supply for fear of fatal hazard.

2.2 Installation site requirements

To ensure the normal operation of the equipment, the installation site shall meet the following requirements.

Installation requirements

- ◆ Ensure that the installation location is firm enough to support the control terminals and accessories.
- ◆ Ensure that the installation location is big enough for the installation of the control terminal, and that the control terminal is free from other obstructions and barriers.

Temperature and humidity requirements

- ◆ In order to ensure the normal operation and service life of the equipment, the working environment shall be of natural temperature and humidity, and high humidity and temperature shall be avoided. In case of direct sunlight in the summer, it is recommended to take simple shading means, but please keep it spaced from the control terminal appropriately.
- ◆ The equipment shall not be operated in the environment not up to the temperature and humidity requirements for a long time, otherwise, it will be damaged.
- ◆ If the equipment is operated in the environment with high relative humidity, insulation materials may be degraded to cause improper insulation or even electric leakage, and sometimes, the mechanical properties of materials may be changed and metal parts may become rusty.
- ◆ If the equipment is operated in the environment with low relative humidity, the insulating strip will shrink and the static electricity will be generated, thus damaging the circuit on the equipment.

Cleanliness requirements

- ◆ The installation and operation environment of equipment also makes demands on the content of salt, acid and sulfide in the air. Some harmful substances will accelerate the corrosion of metal and the aging of certain parts. Therefore, measures shall be taken to reduce the invasion of harmful gases (such as: sulfur dioxide, hydrogen sulfide, nitrogen dioxide, chlorine).

Power supply requirements

- ◆ Voltage input: Select the steering motor according to the vehicle battery, and select the input voltage according to the voltage of the steering motor (generally, the starting voltage of the vehicle shall be met).

Connect the terminals of the power line to the positive and negative terminals of the battery accordingly. Avoid direct contact with the wiring harness and the high temperature object.

2.3 Installation tools

Before the formal installation, please prepare the following tools.

Assembly Tools for FJDynamics Autosteering Kit				
No.	Tool	Model	Quantity	Purpose
1	Phillips screwdriver	Medium size	1	Angle sensor installation
2	Slotted screwdriver	Medium size	1	Hook fastening
3	Inner hexagon wrench	3	1	Angle sensor installation
4		4	1	1. Steering wheel assembly 2. Installation of splined sleeve
5		5	1	Fixing of motor lower bracket
6	Hexagon wrench	11	1	Fastening of U-bolt for fixing control terminal
7		13	2	1. Antenna bracket installation; 2. Steering motor clamp bracket installation.
8		24	1	GNSS antenna bolt
9		12/14	2	Battery wire installation (the specification of bolts depends on the model of vehicle)
10		18/21	1	Removal and installation of front axle bolts (the specification of bolts depends on the type of axle)

11	Socket wrench	24/27	1	Removal of steering wheel bolt (lengthened socket) (the specification of socket depends on the type of steering column).
12	Utility knife	/	1	Unpacking
13	Scissors	/	1	Strap scissoring
14	Tape measure	5m	1	Measurement of body parameters

2.4 Unpacking and inspection

After the above tools are ready, please check the following list of goods.

No.	Name	Quantity	Remarks
Packing box of control terminal			
1	IMU	1	/
2	Control terminal	1	/
3	L sealing bag	1	20×28cm
4	Software Instructions	1	
5	Hardware Instruction	1	
6	Product Certification	1	
7	Screen Protector	2	
8	GNSS antenna	2	/
9	4G antenna	1	/
10	Radio antenna	1	/
Packing box of electrical steering wheel and wiring harness bracket			
1	steering wheel	1	
2	Steering motor	1	12/24V
3	S Sealing Bag	1	For installation of the motor and steering wheel
4	Hexagon socket head cap screws M5×12	6	
5	spring washer 5	6	
6	Plain washer 5	6	
7	spring washer 4	6	
8	Plain washer 4	6	
9	Hexagon socket head cap screws M4×	6	

	14		
10	Hexagon socket head cap screws M6×16	2	
11	spring washer 6	2	
12	Flat washer 6	2	
13	#1 GNSS Feeder	1	Feeder of 4G/Radio SuckerSuction cup
14	#2 GNSS Feeder	1	
15	4G antenna Suction cup	1	
16	Radio antenna Suction cup	1	
17	IMU wiring harness	1	
18	Steering motor connecting cable	1	
19	Steering motor main power cable	1	
20	Intelligent Main Wiring Harness (II)	1	
21	Control terminal bracket (type II)	1	
22	S Sealing Bag	1	For installation of angle sensor assembly
23	Fixing bracket	1	
24	Angle sensor bracket	1	
25	Hexagon socket head cap screws M3×6	2	
26	spring washer 3	2	
27	Plain washer 3	2	
28	Cross recessed pan head screw, single coll spring lock washer and plain washer assemblies M5×16	2	
29	Hexagon nut M5	2	
30	Cross recessed countersunk head screws M5×8	2	
31	Angle sensor wiring harness	1	
32	Hose hoop	2	
33	GNSS antenna bracket	2	
34	Antenna connector	1	
35	Welded casing	2	
36	S Sealing Bag	1	For installation of the antenna bracket
37	Outer hexagon bolt 5/8-11	2	

38	Hexagon bolt M5×16	4	
39	Hexagon nut M5	4	
40	Hexagon bolt M8×50	4	
41	Hexagon nut M8	4	
42	Spring washer 8	4	
43	Plain washer 8	8	
44	Plain washer 16	4	
45	S Sealing Bag	1	
46	Self-tapping screw ST4.8×25F	1	
47	Cross recessed pan head screw, single coll spring lock washer and plain washer assemblies M6×14	4	
48	Nylon strap	20	All standard parts are packed together
49	Suction cup base	2	
50	L Sealing Bag	1	

Note: The splined sleeve, steering motor bracket and Angle Sensor bracket are not included in this table, they are available at the dealer's premise, and the dealer will install according to the model.

The items listed above are for general cases only, and may be different as the actual case is (subject to the order contract). Please check the received product carefully against the packing list or order contract. If you have any questions or errors, please contact the dealer.

3. Installation

Please read Chapter 2 carefully and ensure that the requirements described in Chapter 2 are met.

3.1 Check before installation

Before installation, make a detailed plan for the installation location, power supply and wiring of the equipment, and confirm that:

- ◆ The installation location is spacious enough to meet installation and cooling requirements of the product.
- ◆ The installation site meets the temperature and humidity requirements of the equipment.

- ◆ The installation site meets the power supply and current requirements of the equipment.
- ◆ The selected power supply meets the power requirements of the system.
- ◆ The installation site meets the siting requirements of the equipment.
- ◆ For the equipment supplied to specific users, please confirm whether the equipment meets the special supply requirements before installation.

3.2 Installation process



3.3 Precautions during installation

- ◆ Do not connect the power supply to the equipment during installation.
- ◆ Please place the equipment in a dry place.
- ◆ Avoid placing the equipment in a high temperature environment.
- ◆ Please keep the equipment away from high voltage cables.
- ◆ Please keep the equipment away from the environment exposed to strong thunderstorms and strong electric fields.
- ◆ Please power off the equipment before cleaning.
- ◆ Please do not clean the equipment with liquids.
- ◆ Please do not open the case.
- ◆ Please fix the equipment firmly.

4. Installation steps

4.1 Installation of electrical steering wheel

4.1.1 Materials required for installation of electrical steering wheel

No.	Name	Quantity
1	Dust-proof Cap and Bonding Logo	1
2	Hexagon socket screw M5x16	6
3	Spring washer 5	6
4	Plain washer 5	6
5	Steering wheel	1
6	Hexagon socket head cap screws M4×14	6
7	Spring washer 4	6
8	Plain washer 4	6
9	1# splined sleeve	1
10	Steering motor	1
11	Motor bracket 2	1

12	Plain washer 6	2
13	Spring washer 6	2
14	Hexagon socket head cap screws M6×16	2

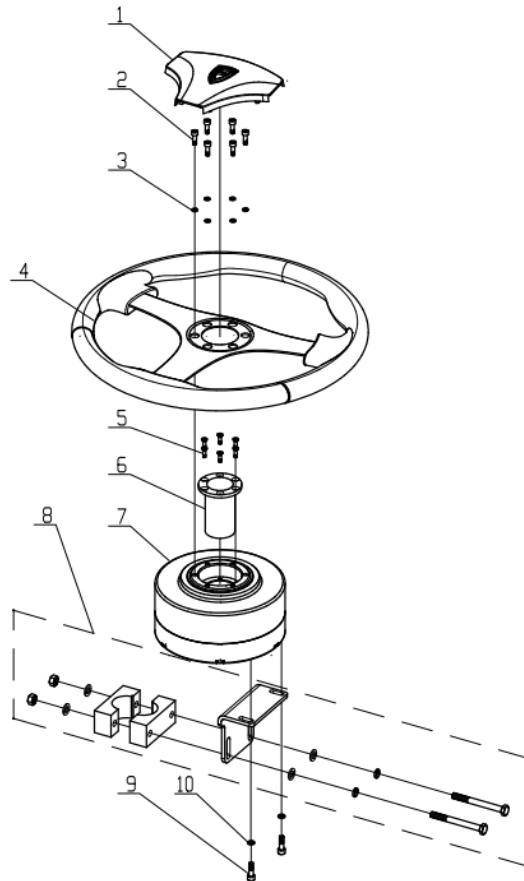

- The list of materials involved in the installation of the motor bracket 2 (No. 11 in the figure above):

No.	Name	Quantity
1	Hexagon nut M8	2
2	Plain washer 8	4
3	Steering hoop block	2
4	Steering motor mounting bracket	1
5	Washer 8	2
6	Hexagon bolt M8x50	2

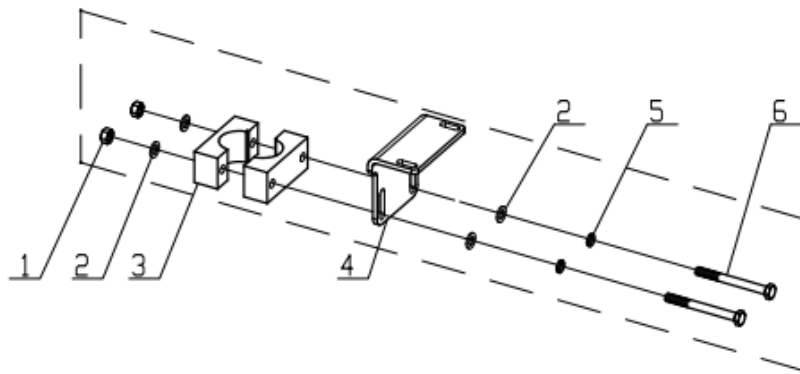

4.1.2 Installation steps of electrical steering wheel

1. Remove the steering wheel of the sample vehicle: Remove the protective cap of the steering wheel, and then undo the lock nut (keep the nut for future installation), and pull out the steering wheel.

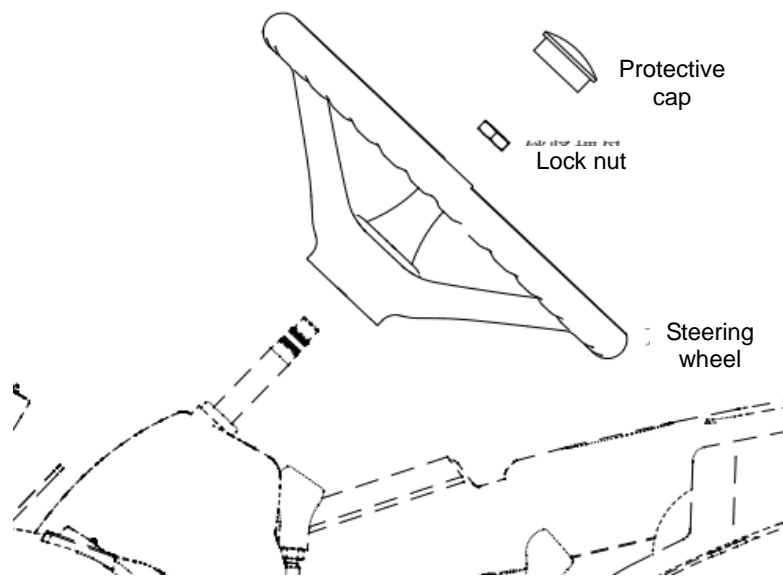

2. Select the splined sleeve according to the type of spline of the steering column: Install the splined sleeve on the steering column and rotate it leftwards and rightwards until no shaking and clearance is involved. For the sample vehicle, the 1# splined sleeve is applicable.

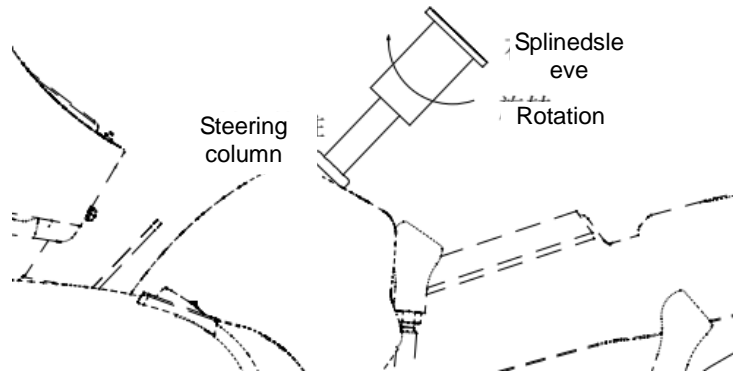

3. Put the 1# splined sleeve into the steering motor, and fix it with 6 hexagon socket head cap screws M4×14 and 6 spring washers 4 and plain washers 4.

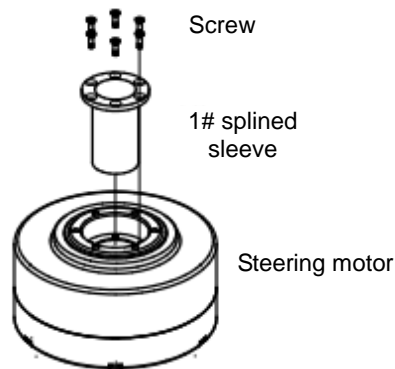

4. Install the steering wheel and fix it with 6 hexagon socket screws M5×16, spring washer 5 and plain washer 5.

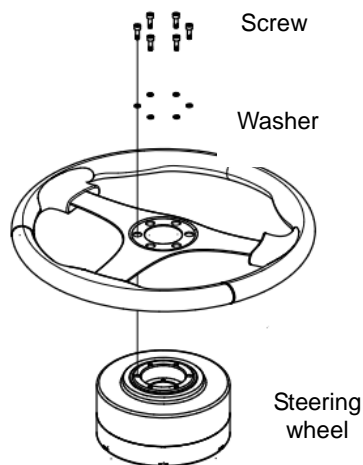

5. Install the motor bracket (Note: The structure of instrument panel below the steering wheel depends on the model, and please select the motor bracket accordingly. For the sample vehicle, the motor bracket 2 is used), and fix it with 2 hexagon socket screws M6×16 and washer 6 (do not tighten the bolts at this moment).

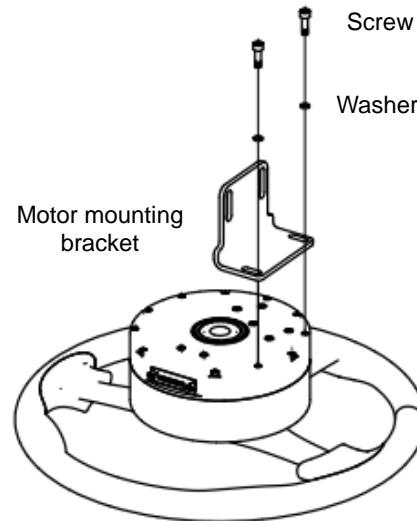

Installation of steering motor & steering wheel assembly

6. Install the steering motor & steering wheel assembly onto the sample vehicle with steering wheel removed, adjust the motor connector to the position convenient for wiring harness connection, install the steering hoop block, adjust the position of the motor mounting bracket, and finally tighten the corresponding standard parts, so as to ensure that the bracket is firm and reliable and the motor outer ring will not rotate with it.

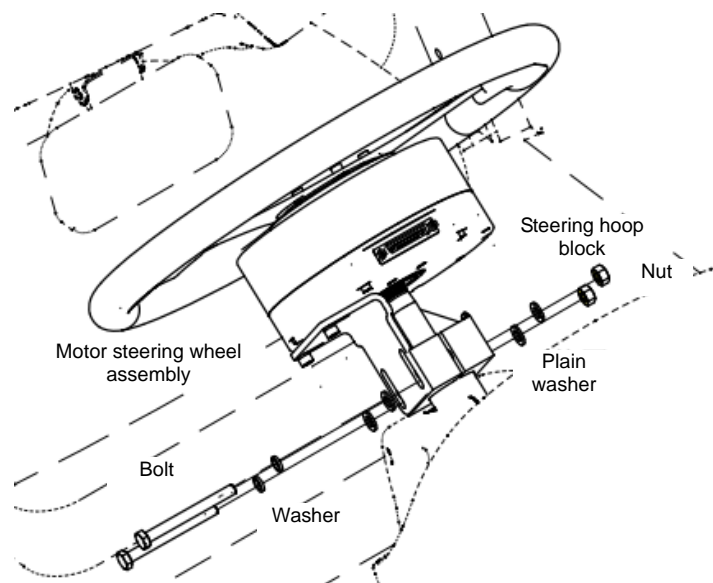

7. Install the original lock nut removed in step 1, and then install dust-proof cap and bonding logo.

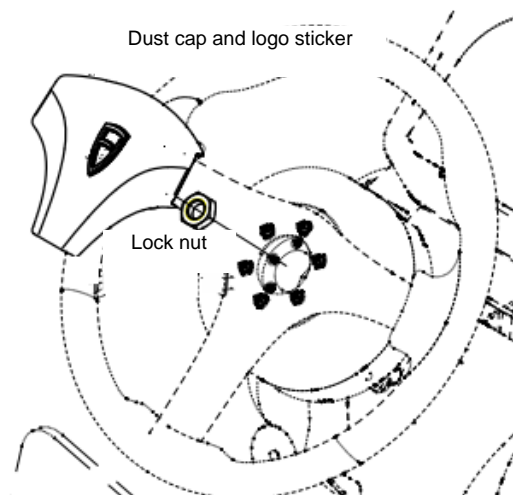

4.2 Installation of angle sensor

4.2.1 Materials required for installation of angle sensor

No.	Name	Quantity
1	Hose hoop	2
2	Hexagon bolt M5x16	2
3	Fixing bracket	1
4	Angle sensor bracket	1
5	Hexagon socket head cap screws M3×6	2
6	Spring washer 3	2
7	Plain washer 3	2
8	Angle sensor assembly	1
9	Hexagon nut M5	2
10	Angle sensor bracket 3	1
11	Cross recessed countersunk head screws M5×8	2

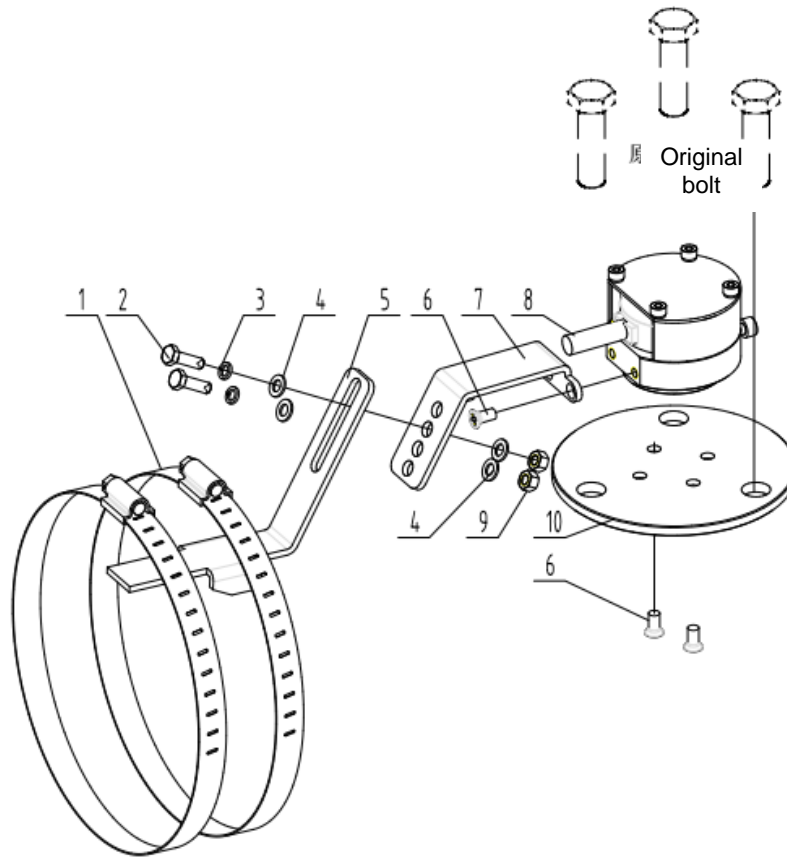

4.2.2 Installation steps of angle sensor

1. Observe the installation space structure of the front axle spindle of the left/right wheel of the sample vehicle, and select a proper mounting bracket. (The figure below shows the three-hole installation method, and thus, the angle sensor bracket 3 is selected)

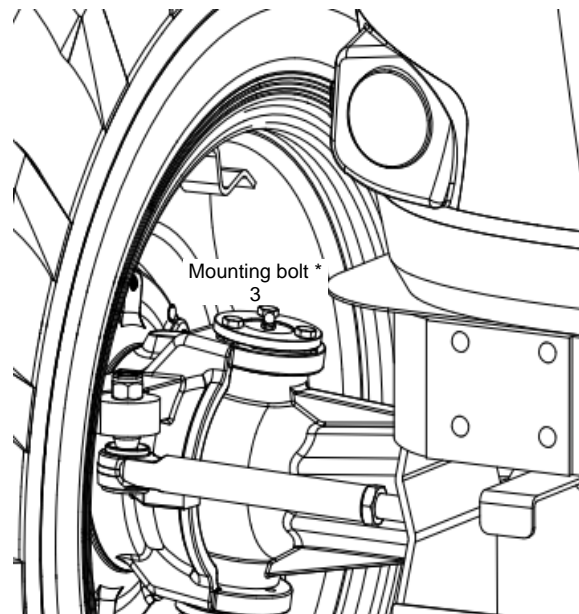

2. Install the angle sensor bracket and fix it with 2 Hexagon socket head cap screws M3×6 and washers.

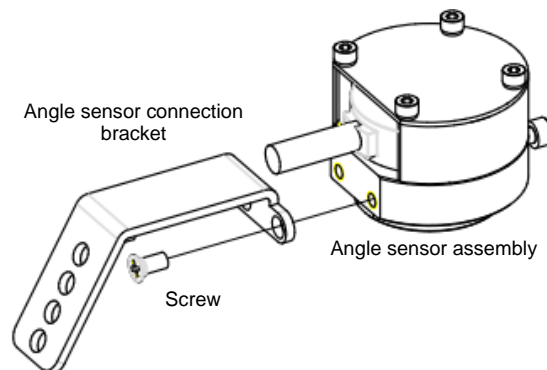

3. Install the angle sensor bracket selected in step 1 and fix it with 2 cross recessed countersunk head screws M5x8.

(Note: The plane a should be parallel to plane b, and line c should be parallel to line d).

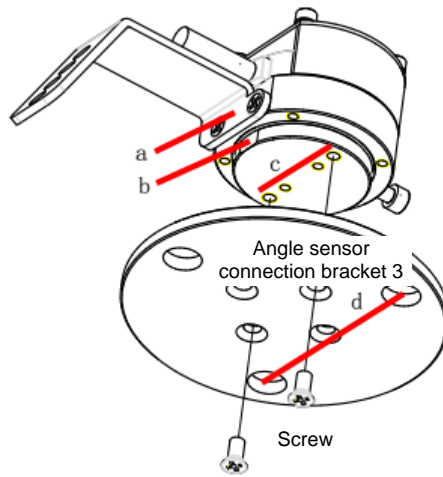

4. Remove the front axle spindle bolts and grease nozzles of the sample vehicle.

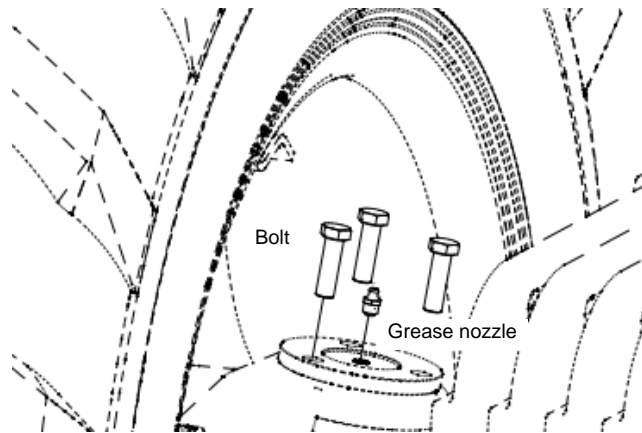

5. Install the angle sensor assembly in step 3 and then fix it with bolts in step 4.

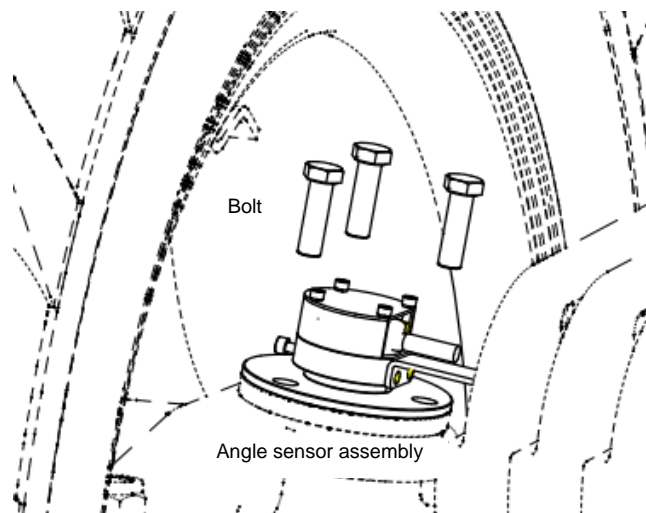

6. Install the fixing bracket and adjust its position, and then connect the angle sensor assembly with 2 hexagon bolts M5x16, hexagon nuts M5, spring washer 5 and plain washer 5, and then fix the fixing bracket with the front axle housing using 2 hose hoops 165 to ensure the stability and reliability.

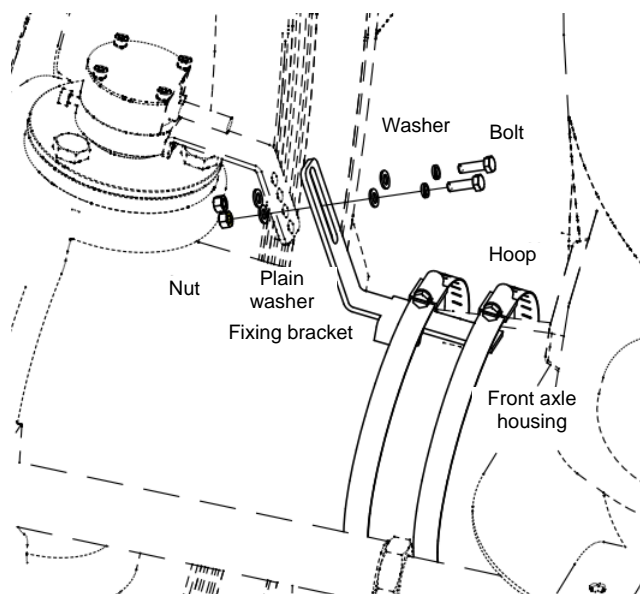

4.3 Installation of antenna

4.3.1 Materials required for installation of antenna (suction cup 4G antenna and Radio antenna)

No.	Name	Quantity
1	Welded casing	2
2	Hexagon nut M5	4
3	Hexagon bolt M5x16	4
4	GNSS antenna	2
5	Plain washer 16	2
6	GNSS antenna bracket	2
7	Hexagon nut M8	4
8	Plain washer 8	8
9	Washer 8	4

10	Hexagon bolt M8x50	4
11	Radio antenna	1
12	Antenna connector	1
13	4G antenna	1
14	Outer hexagon bolt 5/8-11	2
15	Suction cup base	2
16	Spring washer	2

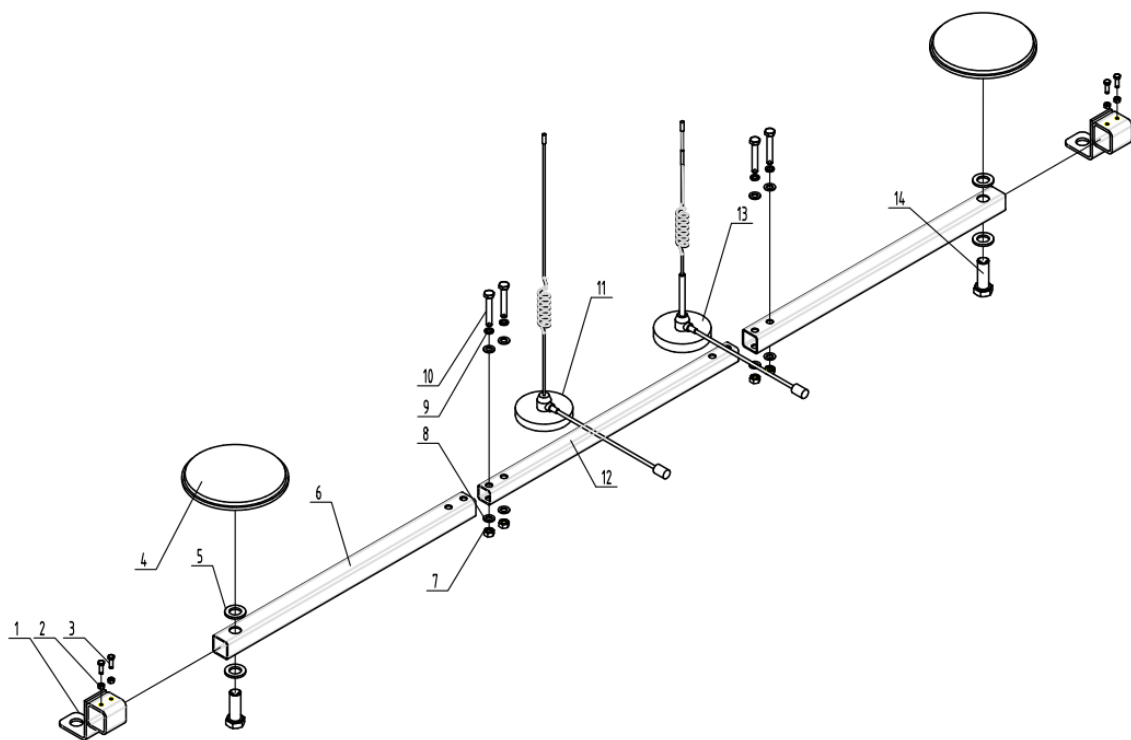

4.3.2 Installation steps of antenna

1. Assemble the antenna bracket, insert 2 GNSS brackets into the antenna connecting bracket, align the 4 holes, and then fix it with 4 hexagon bolts M8x50, washer 8, plain washer 8 and hexagon nut M8.

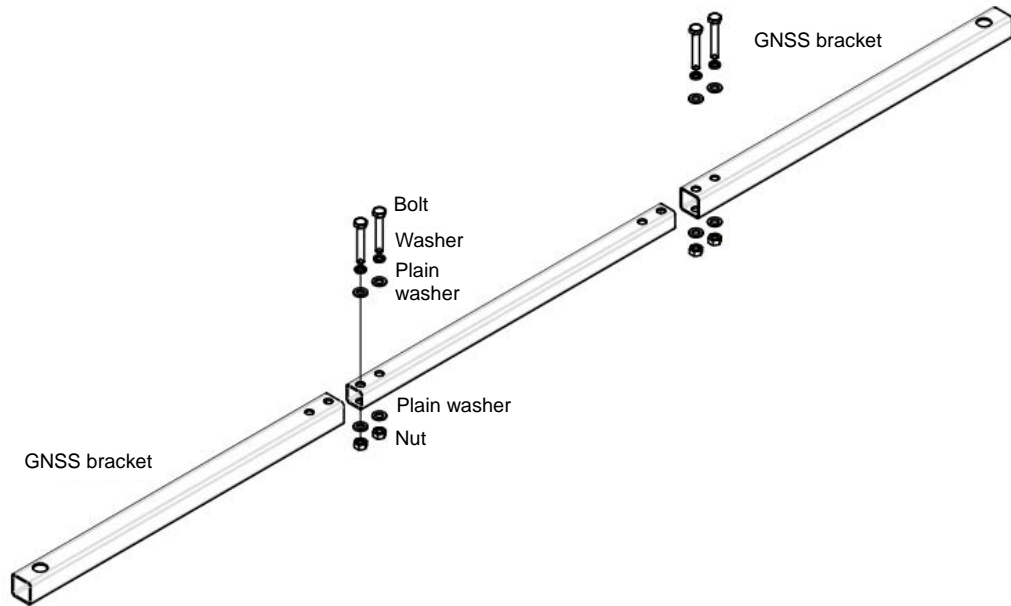

2. Insert the casing weldment from both ends, and install 4 hexagon bolts M5x16 and hexagon nuts M5 (do not tighten them at this moment), namely, the casing weldment can be moved leftwards and rightwards on the mushroom head bracket.

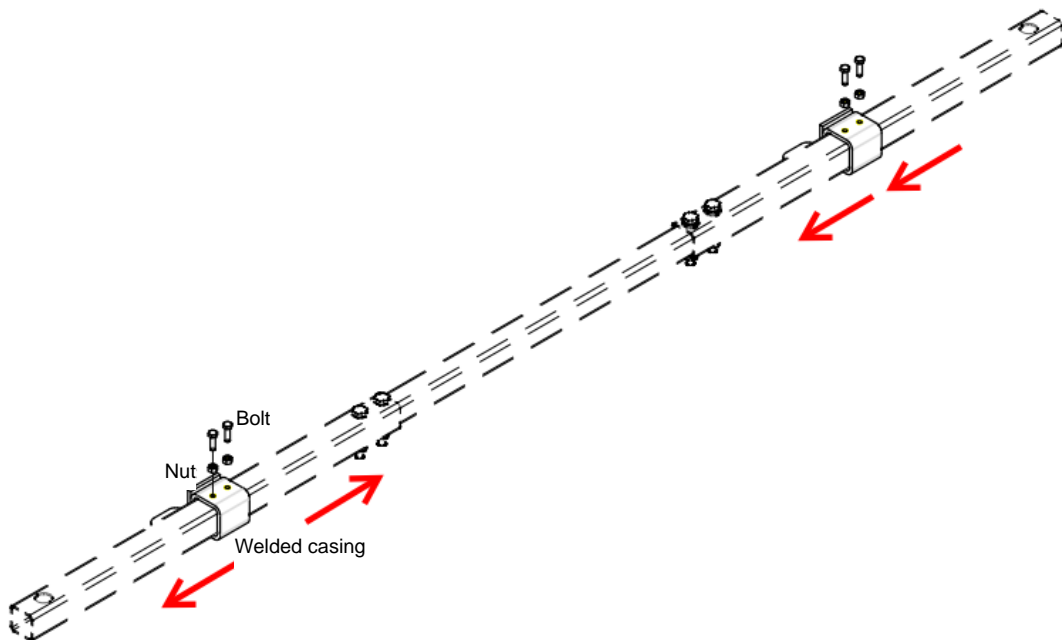

3. Install the GNSS antenna and fix it on both ends of the bracket with 2 outer hexagon bolts 5/8-11 and 4 plain washers.

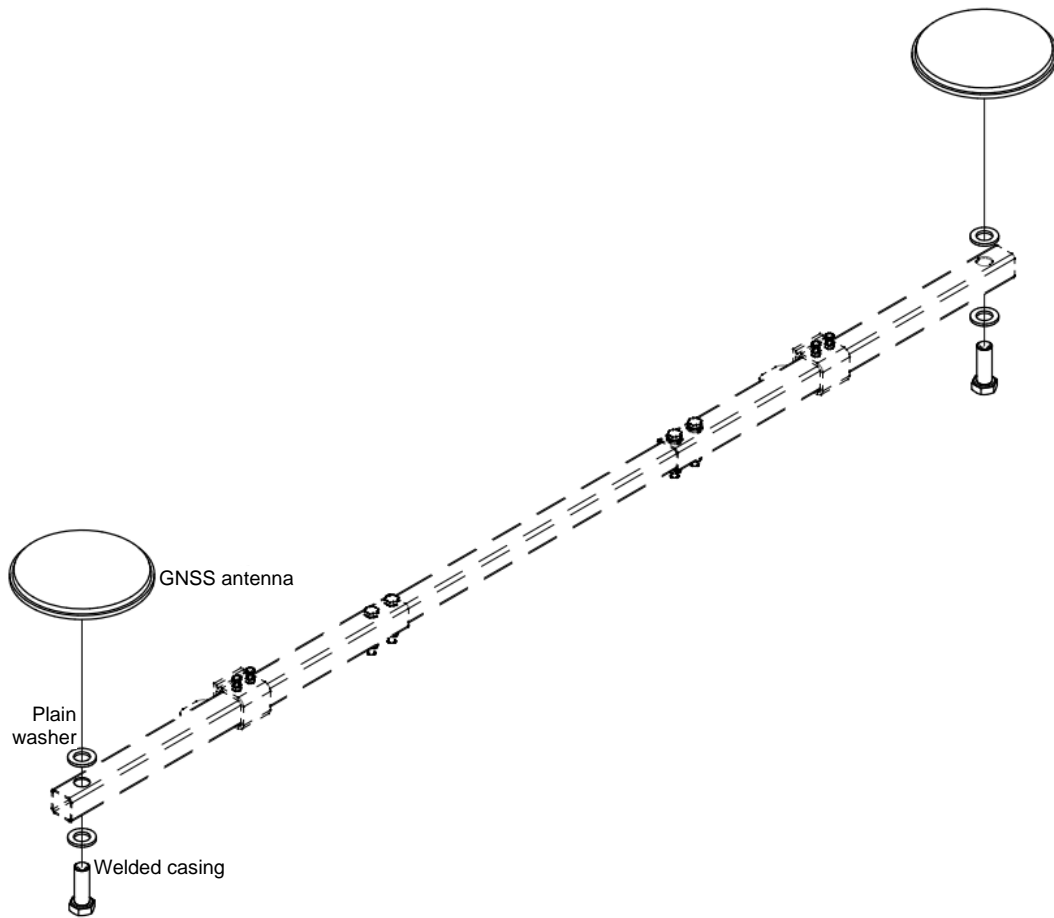

o

4. Install the antenna bracket assembly on the ceiling of the vehicle, and ensure that the 2 GNSS antennas are symmetrical and perpendicular to the body center by adjusting the position of the casing weldment. After that, tighten 4 hexagon nuts M5 to ensure that the antenna bracket assembly cannot move leftwards and rightwards, and then fix the antenna bracket assembly through the ceiling screws.

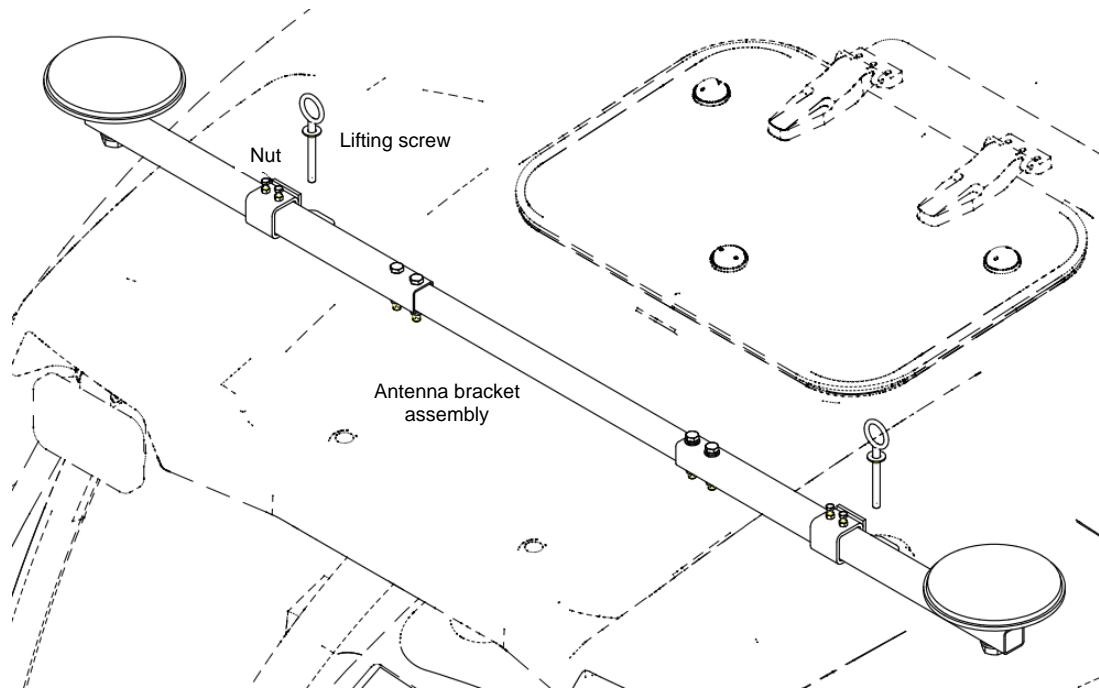

5. Attach the 4G antenna and Radio antenna (suction cup type) bracket onto the antenna bracket assembly.

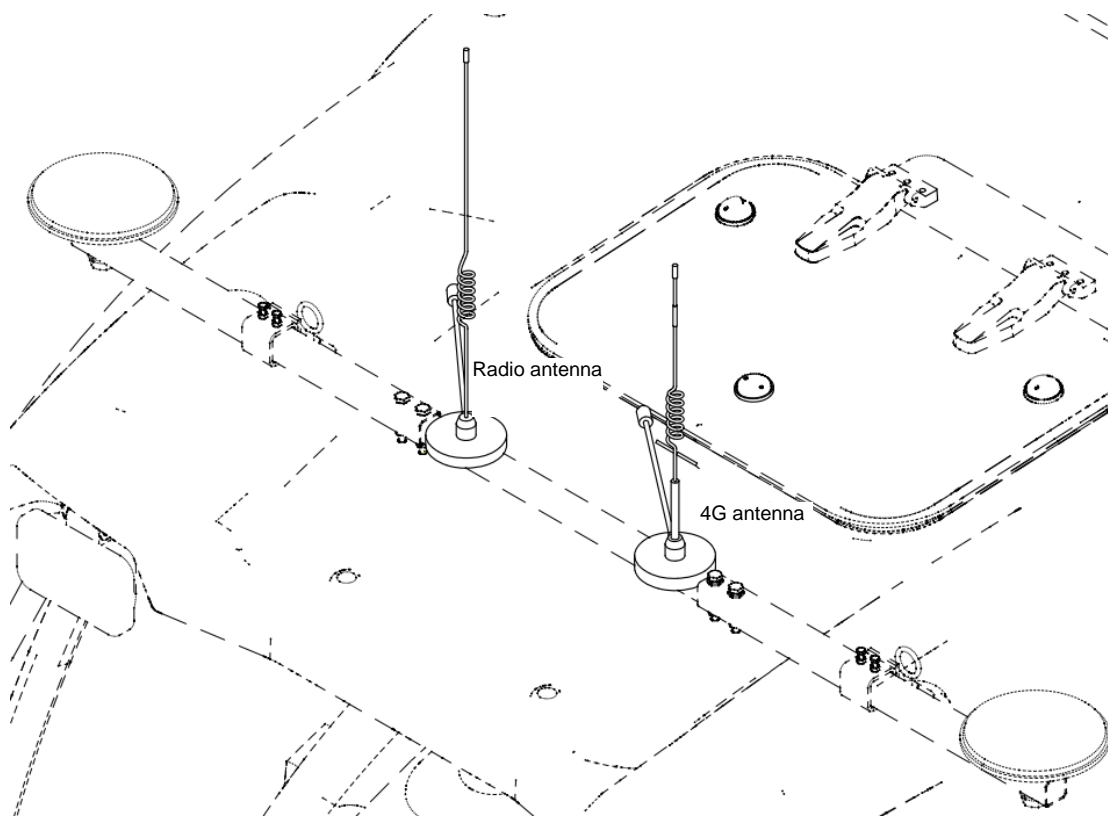

4.4 Installation of IMU

4.4.1 Materials required for installation of IMU

No.	Name	Quantity
1	IMU	1
2	Self-tapping screw ST4.8×25	4

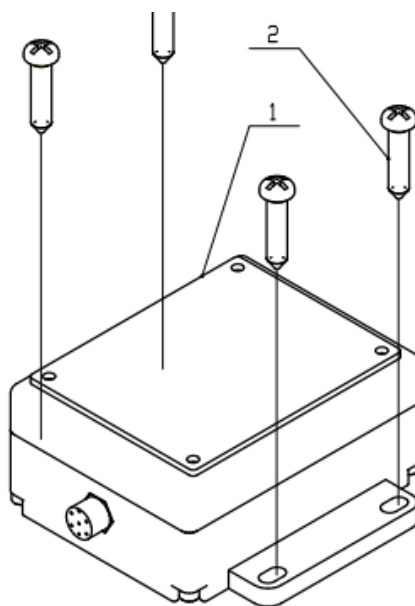

4.4.2 Installation steps of IMU

1. Install the IMU at a horizontal position inside the cab, and then align the connection interface with the traveling direction of the vehicle, and fix it with 4 self-tapping screws.

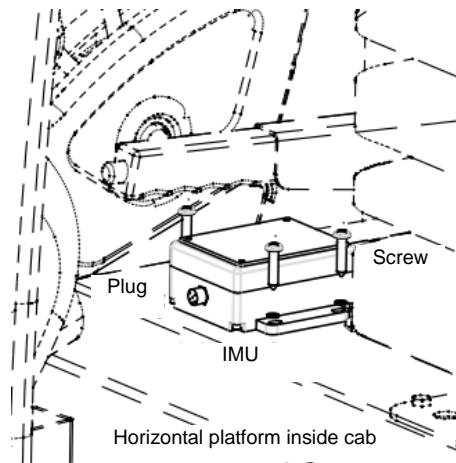

Note: The IMU shall be placed horizontally, with the plug in the direction same as the traveling direction of the vehicle.

4.5 Installation of control terminal

4.5.1 Materials required for installation control terminal

No.	Name	Quantity	Remarks
1	Control terminal	1	
2	Panhead bolt with elastic plain washer M6x14	4	
3	Connecting base	1	Provided with the control terminal bracket assembly
4	Mounting bracket	1	
5	Nut	4	
6	Base	1	
7	U-hook	2	

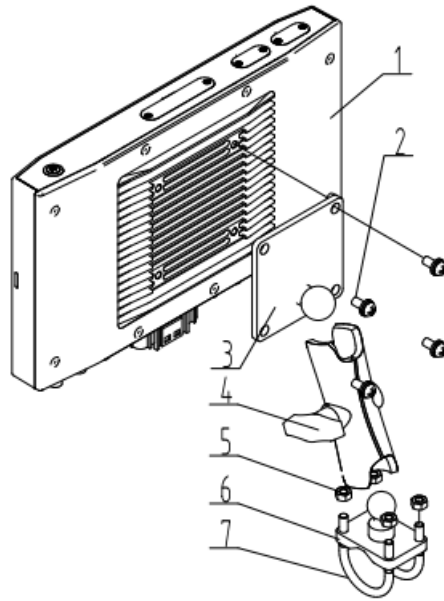

4.5.2 Installation steps of control terminal

1. Select a proper round steel handle position on the right door, install the bracket base, and fix it with U-bolts.

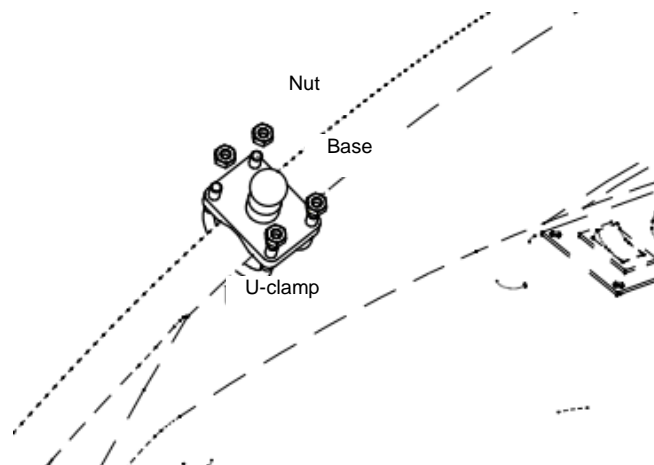

2. Install the control terminal on the transition plate and fix it with 4 M6×14-8.8-Zn-c1B panhead bolts with elastic plain washers meeting the requirements in GB/T 9074.4.

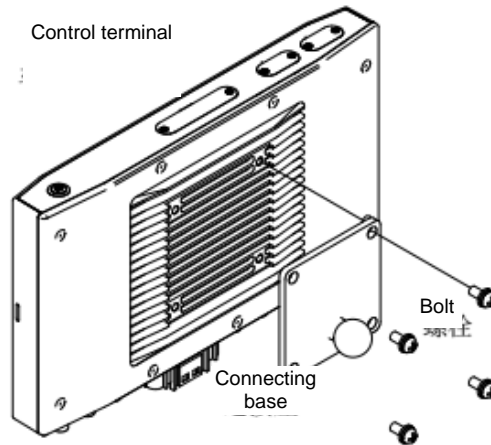

3. Rotate the mounting bracket handle counterclockwise and install the control terminal that is installed in step 2 into the ball socket of the mounting bracket.

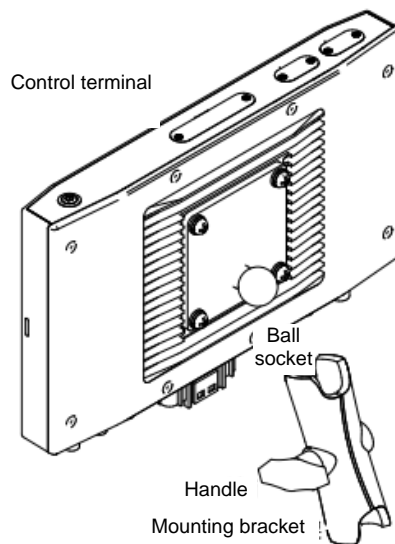

4. Install control terminal installed in step 3 onto the base ball head and rotate it clockwise to ensure that the control terminal is secured reliably without shaking.

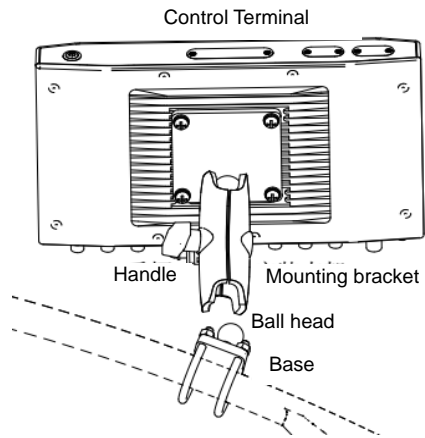

4.6 Installation of cable harness

4.6.1 Materials required for installation of cable harness

No.	Name	Quantity
1	#1 GNSS Feeder	1
2	#2 GNSS Feeder	1
3	Radio antenna connecting cable	1
4	4G antenna connecting cable	1
5	Intelligent Main Wiring Harness (II)	1
6	IMU wiring harness	1
7	Steering motor connecting cable	1
8	Angle sensor wiring harness	1
9	Steering motor main power cable	1

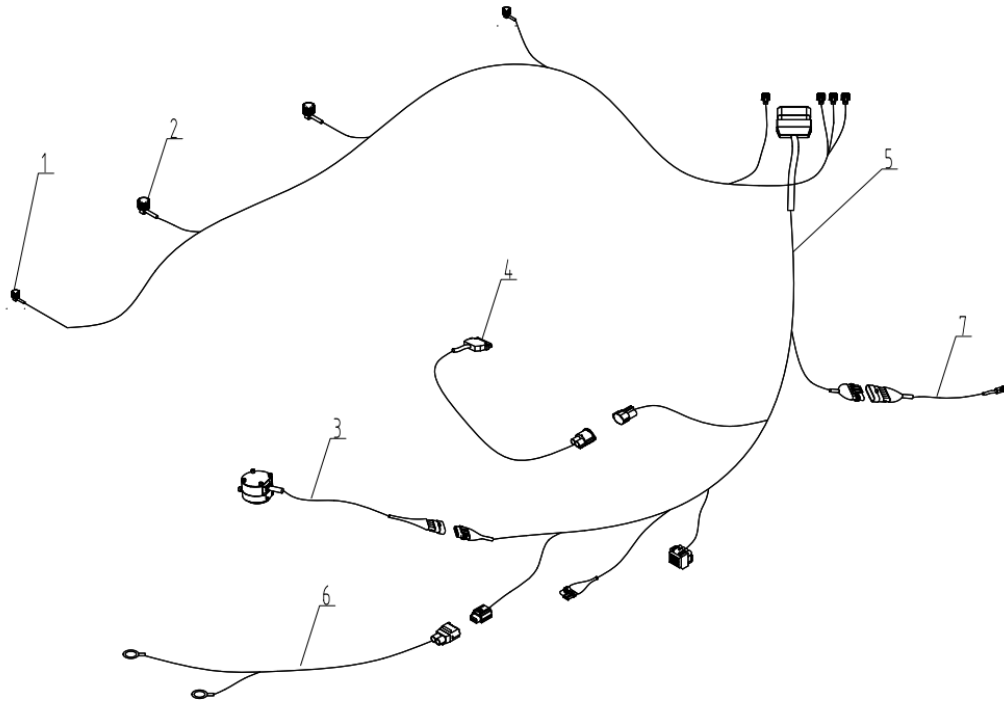

4.6.2 Installation steps of cable harness

1. Lay the wiring harness in a reasonable direction and away from the heat source, and fix it with straps. For the wiring harness connector, refer to the figure below. Note: Connect the main power cable to the negative terminal of the power supply, and then to the positive terminal, and finally, connect other plugs.

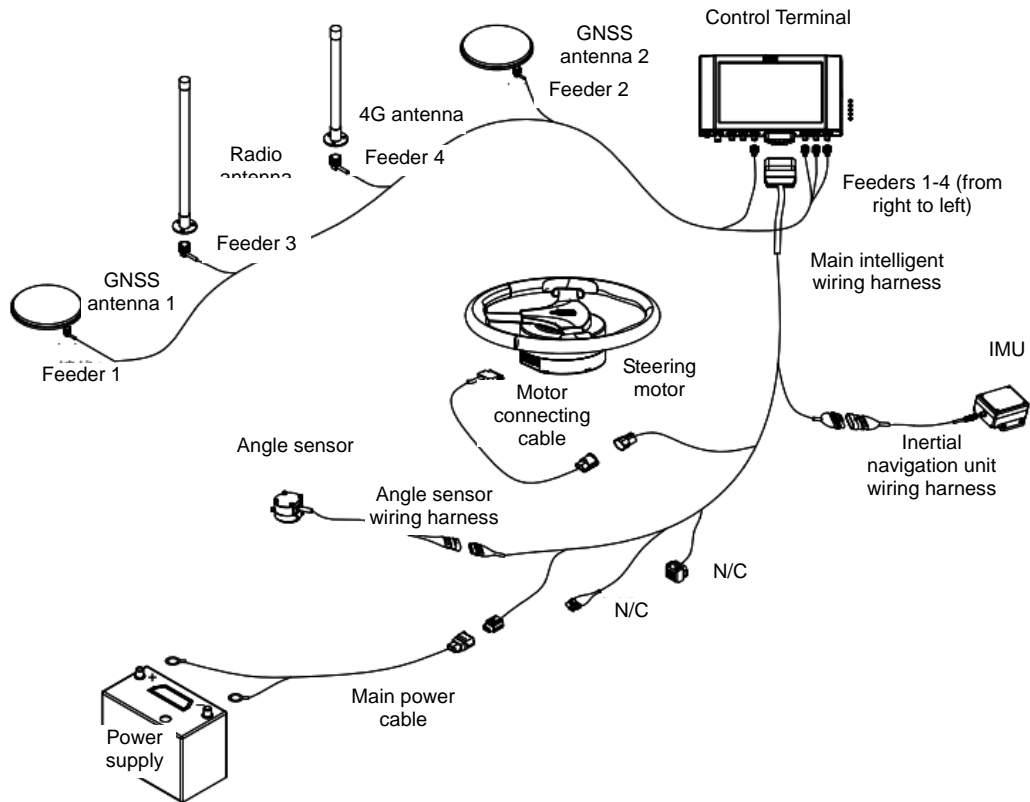

4.7 Installation of SIM card

4.7.1 Materials required for installation of SIM card

No.	Name	Quantity
1	SIM Card	1
2	Thimble	1
3	tweezers	1
4	Phillips screwdriver	1

SIM Card Note:

1. Please purchase a SIM card that supports the frequency bands of the 4G module of the in-vehicle display and control terminal. The 4G module currently used on FJDynamics Autosteering kit is EC25-G, which supports the following frequency bands. Please confirm with the SIM card supplier that the SIM card also supports the following frequency bands:

LTE FDD: B2/B4//B5/B7/B12/B13/B25/B26

LTE TDD: B38/B41

WCDMA: BAND 2/BAND 4/BAND 5

E-GSM850, DCS1900

2. Please make sure that the data service of the SIM card you purchased has been activated.

3. After the SIM card is installed, please confirm whether the APN and network type need to be set according to the Instructions. If necessary, please turn on the in-vehicle display and control terminal and complete the network configuration in the built-in Android system.

4.7.2 Installation of SIM card

1. Please use a Phillips screwdriver to unscrew the T3 cover of the top control box of the in-vehicle display and control terminal to expose the following SIM card insertion interface.

2. With the SIM card chip facing up, use thimble and tweezers to slowly insert the SIM card into the appropriate position of the SIM card slot in the top T3 interface.

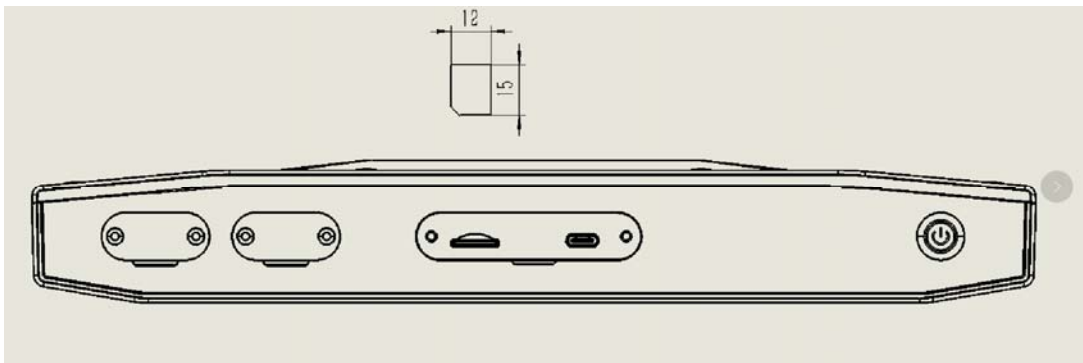

Now, the hardware installation of the FJDynamics autosteering kit has been completed.

5. System debugging

5.1 Debugging site requirements

1. The agricultural machinery shall be in good conditions and all parts shall work normally.
2. The agricultural machinery shall not be attached with accessories.
3. The agricultural machinery shall be balanced by counterweights.

3. There shall be no tall trees, buildings and other obstacles affecting the satellite signal around the debugging site.
4. There shall be no high voltage wire within 150m around the debugging site.
5. The debugging site shall be horizontal, with a length not less than 50m and a width not less than 10m.
6. The floor of debugging site shall be paved with cement or asphalt.
7. The debugging site shall not be on a public road. During the debugging, there shall be no irrelevant personnel around the agricultural machinery to prevent personal injuries.

5.2 Power-on and Startup

5.2.1 Inspection before power-on

1. Check whether the power connection is correct
2. Check whether the power supply voltage is consistent with the requirements

5.2.2 Inspection after power-on

1. Check whether the control terminal power light is on after power-on.
3. Check whether the control terminal program can be started normally after its power switch is pressed.

5.3 Parameter Calibration

For details on parameter calibration, please refer to Section 2, Chapter IV of the accompanying Software Operation Instruction for FJDynamics Autosteering Kit.

6. Appendix

6.1 Main hardware and its specifications

No.	Assembly	Components	Specifications
1	Control Terminal	Control Terminal	Size: 300×190×43mm; 10.1-inch capacitive touch screen, LED backlight, 1280*800 pixels, 700cd/m2 LCD; Dual speaker; 2G RAM, 8G ROM; Various digital and analog output interfaces, etc. Power supply: 10-30V; RF signal, Positioning satellite and 4G signal etc.; Operating temperature: -30℃~+70℃; Storage temperature: -40℃~+85℃; IP rating: IP65; Relative Humidity: 0% to 95%, @40 ℃ (non-condensation) WIFI specification: 2.4GHz frequency band, frequency range: 2412-2462MHz, output power: 25.28dBm
2	Antenna Assembly	GNSS Antenna	Frequency range: GPS L1/BDS B1/GLONASS G1/Galileo E1 Operating voltage: 3.3~12VCD; Operating current: ≤45mA; Size: 152*63mm Minimum signal level for each GNSS: GPS:-128.5dBm GLONASS:-131dBm BDS:-133dBm

3		4G Antenna	<p>Suction cup antenna:</p> <p>Frequency range: LTE B2/B4//B5/B7/B12/B13/B25/B26/B38/B41;</p> <p>WCDMA: BAND 2/BAND 4/BAND 5</p> <p>E-GSM850, DCS1900</p> <p>VSWR: ≤ 2.0;</p> <p>Gain (dBi): 2;</p> <p>Polarization: Linear, Vertical; Antenna size: $\Phi 370 \times 82 \text{mm}$; Operating temperature: $-20^{\circ}\text{C} \sim +60^{\circ}\text{C}$</p>
4		Digital Radio Antenna	<p>Suction cup antenna:</p> <p>Receiver Frequency range:</p> <p>410-470MHz;</p> <p>VSWR: ≤ 2.0;</p> <p>Gain(dBi): 1 ± 0.5;</p> <p>Impedance (Ω): 50;</p> <p>Polarization: Linear, Vertical;</p> <p>Antenna size: $\Phi 490 \times 82 \text{mm}$; Operating temperature: $-20^{\circ}\text{C} \sim +60^{\circ}\text{C}$</p>
5	IMU	IMU	<p>Power input: 5V;</p> <p>Acceleration accuracy: 0.09mg;</p> <p>Gyroscope accuracy: $0.004^{\circ} / \text{s}$;</p> <p>Heading angle accuracy: 1° ;</p> <p>Roll and pitch angle: 0.5°</p>
6	Angle Sensor	Angle Sensor	<p>Power supply: 5V;</p> <p>Update frequency: typical 3.4KHz;</p> <p>Resolution: $< 0.1^{\circ}$;</p> <p>IP rating: IP67;</p> <p>Operating temperature: $-40^{\circ}\text{C} \sim +85^{\circ}\text{C}$</p>

7	Electric Steering Wheel	Steering Wheel	Power supply: 12V/24V; Peak torque: 20Nm (12V); 30Nm (24V); IP rating: IP65
8		Steering Motor (12V /24V)	Power supply: 12V/24V; Peak torque: 20Nm (12V); 30Nm (24V); IP rating: IP65
9		Splined Sleeve	Power supply: 12V/24V; Peak torque: 20Nm (12V); 30Nm (24V); IP rating: IP65

FCC Compliance Notice

Any changes or modifications not expressly approved by the party responsible for compliance could void the user's authority to operate the equipment.

This equipment has been tested and found to comply with the limits for a Class B digital device, pursuant to part 15 of the FCC Rules. These limits are designed to provide reasonable protection against harmful interference in a residential installation. This equipment generates, uses and can radiate radio frequency energy and, if not installed and used in accordance with the instructions, may cause harmful interference to radio communications. However, there is no guarantee that interference will not occur in a particular installation. If this equipment does cause harmful interference to radio or television reception, which can be determined by turning the equipment off and on, the user is encouraged to try to correct the interference by one or more of the following measures:

- Reorient or relocate the receiving antenna.
- Increase the separation between the equipment and receiver.
- Connect the equipment into an outlet on a circuit different from that to which the receiver is connected.
- Consult the dealer or an experienced radio/TV technician for help.

FCC Radiation Exposure Statement

This equipment complies with FCC radiation exposure limits set forth for an uncontrolled environment .

This transmitter must not be co-located or operating in conjunction with any other antenna or transmitter.

This equipment should be installed and operated with minimum distance 20cm between the radiator& your body.

ISED RSS warning

Le présent appareil est conforme aux CNR d'Innovation, Sciences et Développement économique Canada applicables aux appareils radio exempts de licence.

L'exploitation est autorisée aux deux conditions suivantes:

(1) l'appareil ne doit pas produire de brouillage, et

(2) l'utilisateur de l'appareil doit accepter tout brouillage radioélectrique subi, même si le brouillage est susceptible d'en compromettre le fonctionnement.

ISED Radiation Exposure Statement:

This equipment complies with ISED RF radiation exposure limits set forth for an uncontrolled environment.

This transmitter must not be co-located or operating in conjunction with any other antenna or transmitter.

This equipment should be installed and operated with minimum distance 20cm between the radiator & your body.

IC exposition aux radiations:

Cet équipement est conforme aux limites d'exposition aux rayonnements RF de l'ISED pour les environnements non contrôlés. L'émetteur ne doit pas être situé au même endroit qu'une autre antenne ou un autre émetteur et ne doit pas fonctionner avec une autre antenne ou un autre émetteur.

Lors de l'installation et du fonctionnement de cet équipement, la distance minimale entre le radiateur et le corps doit être de 20 cm.