



TESTING LABORATORY
CERTIFICATE #4820.01



FCC PART 15.247

RSS-GEN, ISSUE 5, FEBRUARY 2021 AMENDMENT 2

RSS-247, ISSUE 2, FEBRUARY 2017

TEST REPORT

For

FJ Dynamics Technology Co., Ltd

No.1, Dongfeng-Iseki Road Xiangzhou International Logistic Park Xiangyang, Hubei China

FCC ID: 2AZD3FJNBD25RD
IC: 27079-FJNBD25RD

Report Type: Original Report	Product Type: FJDynamics Autosteering Kit
Report Number:	<u>RDG210317008-00A</u>
Report Date:	<u>2021-07-29</u>
Reviewed By:	Allen Qiao RF Supervisor 
Test Laboratory:	Bay Area Compliance Laboratories Corp. (Dongguan) No.12, Pulong East 1 st Road, Tangxia Town, Dongguan, Guangdong, China Tel: +86-769-86858888 Fax: +86-769-86858891 www.baclcorp.com.cn

TABLE OF CONTENTS

GENERAL INFORMATION	4
PRODUCT DESCRIPTION FOR EQUIPMENT UNDER TEST (EUT)	4
OBJECTIVE	4
TEST METHODOLOGY	4
MEASUREMENT UNCERTAINTY	5
TEST FACILITY	5
DECLARATIONS	5
SYSTEM TEST CONFIGURATION	6
DESCRIPTION OF TEST CONFIGURATION.....	6
EUT EXERCISE SOFTWARE	6
EQUIPMENT MODIFICATIONS.....	9
SUPPORT EQUIPMENT LIST AND DETAILS.....	9
SUPPORT CABLE LIST AND DETAILS.....	9
BLOCK DIAGRAM OF TEST SETUP	9
SUMMARY OF TEST RESULTS	10
FCC §15.247 (i) & §1.1310 & §2.1091 - MAXIMUM PERMISSIBLE EXPOSURE (MPE).....	11
APPLICABLE STANDARD.....	11
CALCULATION FORMULA	11
CALCULATED RESULT	12
RSS-102 CLAUSE 4- EXPOSURE LIMITS	13
APPLICABLE STANDARD.....	13
CALCULATION FORMULA	13
CALCULATED RESULT	14
FCC §15.203, RSS-GEN CLAUSE 6.8- ANTENNA REQUIREMENT.....	15
APPLICABLE STANDARD.....	15
ANTENNA CONNECTOR CONSTRUCTION	15
FCC §15.209, §15.205 & §15.247(d), RSS-247 CLAUSE 5.5, RSS-GEN CLAUSE 8.10 - SPURIOUS EMISSIONS	16
APPLICABLE STANDARD.....	16
TEST SYSTEM SETUP	16
EMI TEST RECEIVER & SPECTRUM ANALYZER SETUP.....	17
TEST PROCEDURE.....	17
CORRECTED AMPLITUDE & MARGIN CALCULATION.....	17
TEST EQUIPMENT LIST	18
TEST DATA.....	18
FCC §15.247(a) (2), RSS-GEN CLAUSE 6.7–6 dB EMISSION BANDWIDTH AND 99% OCCUPIED BANDWIDTH	26
APPLICABLE STANDARD.....	26
TEST PROCEDURE.....	27
TEST EQUIPMENT LIST	27
TEST DATA.....	27
FCC §15.247(b) (3), RSS-247 CLAUSE 5.4 d)- Maximum PEAK Conducted Output Power	39
APPLICABLE STANDARD.....	39
TEST PROCEDURE.....	39
TEST EQUIPMENT LIST	39
TEST DATA.....	40
FCC §15.247(d), RSS-247 CLAUSE 5.5– 100 kHz BANDWIDTH OF FREQUENCY BAND EDGE	41
APPLICABLE STANDARD.....	41

TEST PROCEDURE..... 41
TEST EQUIPMENT LIST 41
TEST DATA..... 42
FCC §15.247(e), RSS-247 CLAUSE 5.2 b)- POWER SPECTRAL DENSITY..... 46
APPLICABLE STANDARD..... 46
TEST PROCEDURE..... 46
TEST EQUIPMENT LIST 46
TEST DATA..... 46

GENERAL INFORMATION

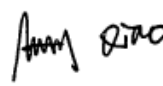
Product Description for Equipment under Test (EUT)

EUT Name:	FJDynamics Autosteering Kit
EUT Model:	FJNBD-2.5RD
Operation Frequency:	2412-2462 MHz(802.11b/g/n ht20)
Maximum Peak Output Power (Conducted):	25.28dBm(802.11b/g/n)
Modulation Type:	DSSS, OFDM
Antenna Gain[▲]:	-0.4dBi
Rated Input Voltage:	DC10-30 V from Battery
Serial Number:	RDG210317008-RF-S1
EUT Received Date:	2021.03.18
EUT Received Status:	Good

Objective

This report is prepared on behalf of *FJ Dynamics Technology Co., Ltd* in accordance with Part 2, Subpart J, Part 15, Subparts A and C of the Federal Communications Commission's rules. RSS-247, Issue 2, February 2017, RSS-Gen Issue 5, February 2021 Amendment 2 of the Innovation, Science and Economic Development Canada.

The tests were performed in order to determine the compliance of the EUT with FCC Rules Part 15-Subpart C, section 15.203, 15.205, 15.207, 15.209 and 15.247 rules, RSS-247, Issue 2, February 2017, RSS-Gen Issue 5, February 2021 Amendment 2 of the Innovation, Science and Economic Development Canada.

Test Methodology

All measurements contained in this report were conducted with ANSI C63.10-2013, American National Standard of Procedures for Compliance Testing of Unlicensed Wireless Devices. And 558074 D01 15.247 Meas Guidance v05r02, RSS-247, Issue 2, February 2017, RSS-Gen Issue 5, February 2021 Amendment 2 of the Innovation, Science and Economic Development Canada.

All emissions measurement was performed and Bay Area Compliance Laboratories Corp. (Dongguan).

Measurement Uncertainty

Parameter	Measurement Uncertainty
Occupied Channel Bandwidth	±5 %
RF output power, conducted	±0.61dB
Power Spectral Density, conducted	±0.61 dB
Unwanted Emissions, radiated	30M~200MHz: 4.55 dB,200M~1GHz: 5.92 dB,1G~6GHz: 4.98 dB, 6G~18GHz: 5.89 dB,18G~26.5G:5.47 dB,26.5G~40G:5.63 dB
Unwanted Emissions, conducted	±1.5 dB
Temperature	±1 °C
Humidity	±5%
DC and low frequency voltages	±0.4%
Duty Cycle	1%
AC Power Lines Conducted Emission	3.12 dB (150 kHz to 30 MHz)

Note: Otherwise required by the applicant or Product Regulations, Decision Rule in this report did not consider the uncertainty. The extended uncertainty given in this report is obtained by combining the standard uncertainty times the coverage factor K with the 95% confidence interval.

Test Facility

The Test site used by Bay Area Compliance Laboratories Corp. (Dongguan) to collect test data is located on the No.12, Pulong East 1st Road, Tangxia Town, Dongguan, Guangdong, China.

The lab has been recognized as the FCC accredited lab under the KDB 974614 D01 and is listed in the FCC Public Access Link (PAL) database, FCC Registration No. : 897218, the FCC Designation No. : CN1220.

The lab has been recognized by Innovation, Science and Economic Development Canada to test to Canadian radio equipment requirements, the CAB identifier: CN0022.

Declarations

BACL is not responsible for the authenticity of any test data provided by the applicant. Data included from the applicant that may affect test results are marked with a triangle symbol “▲”. Customer model name, addresses, names, trademarks etc. are not considered data.

Unless otherwise stated the results shown in this test report refer only to the sample(s) tested.

This report cannot be reproduced except in full, without prior written approval of the Company.

This report is valid only with a valid digital signature. The digital signature may be available only under the Adobe software above version 7.0.

This report may contain data that are not covered by the accreditation scope and shall be marked with an asterisk “★”.

SYSTEM TEST CONFIGURATION

Description of Test Configuration

The system was configured for testing in Engineering Mode, which was provided by the manufacturer.

For 2.4GHz band, total 11 channels are provided:

Channel	Frequency (MHz)	Channel	Frequency (MHz)
1	2412	7	2442
2	2417	8	2447
3	2422	9	2452
4	2427	10	2457
5	2432	11	2462
6	2437	/	/

For 802.11b, 802.11g, and 802.11n ht20 modes were test with channel 1, 6, 11.

The worst-case data rates are determined to be as follows for each mode based upon investigations by measuring the average power and PSD across all data rates, bandwidths, and modulations.

EUT Exercise Software

The software “bat” was used for testing, which was provided by manufacturer. The maximum power was configured as below table, that provided by the manufacturer▲:

Mode	Test Channel	Test Frequency (MHz)	Data Rate	Power level Setting
802.11 b	Low	2412	1Mbps	16
	Middle	2437	1Mbps	16
	High	2462	1Mbps	16
802.11 g	Low	2412	6Mbps	17
	Middle	2437	6Mbps	17
	High	2462	6Mbps	17
802.11n ht20	Low	2412	mcs0	18
	Middle	2437	mcs0	18
	High	2462	mcs0	18

The maximum duty cycle as following table:

Test mode	T _{on} (ms)	T _{on+off} (ms)	Duty Cycle (%)
802.11b	0.865	0.946	91.44
802.11g	0.181	0.276	65.58
802.11n ht20	0.174	0.269	64.68

802.11b

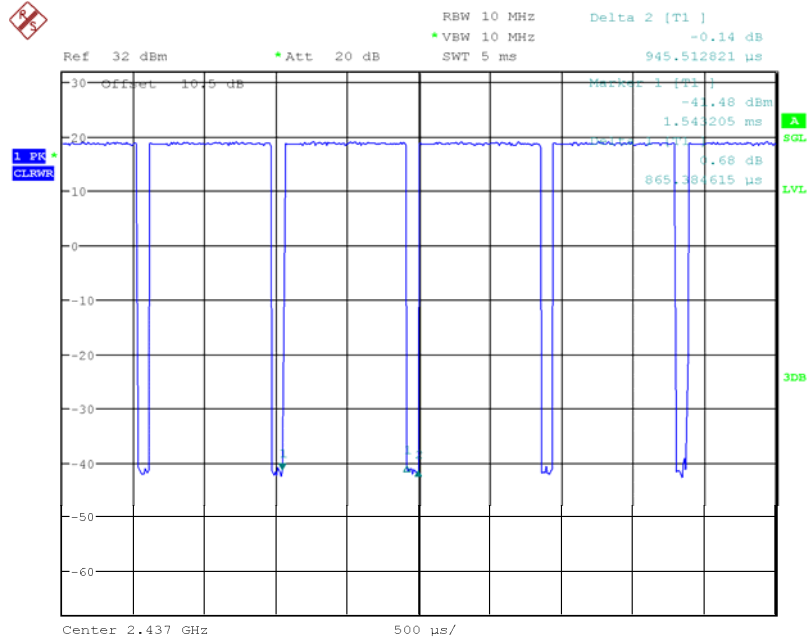

Date: 29.MAR.2021 12:21:16

802.11g

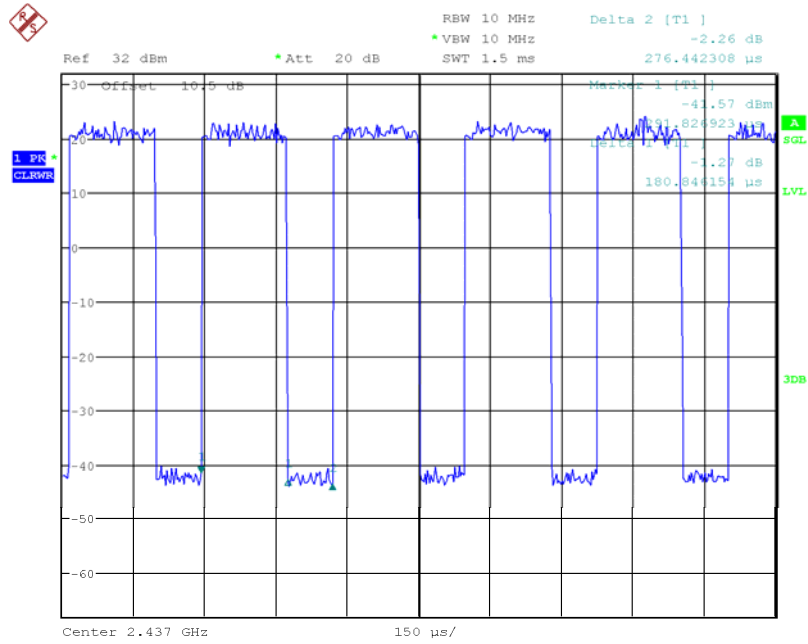

Date: 29.MAR.2021 12:23:32

802.11n ht20

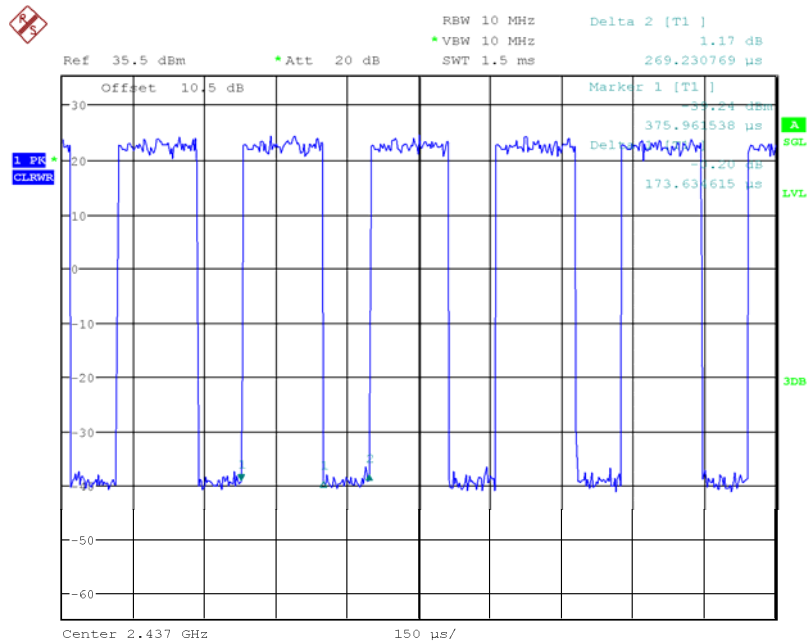

Date: 29.MAR.2021 12:24:50

Equipment Modifications

No modification was made to the EUT.

Support Equipment List and Details

Manufacturer	Description	Model	Serial Number
Panasonic	battery	LC-P1224ST	/
huawei	phone	Mate30	/
Agilent	MXG Vector Signal Generator	N5182B	MY51350142
/	Antenna	/	/

Support Cable List and Details

Cable Description	Shielding Type	Ferrite Core	Length (m)	From Port	To
DC Cable	No	No	3	Battery	EUT

Block Diagram of Test Setup

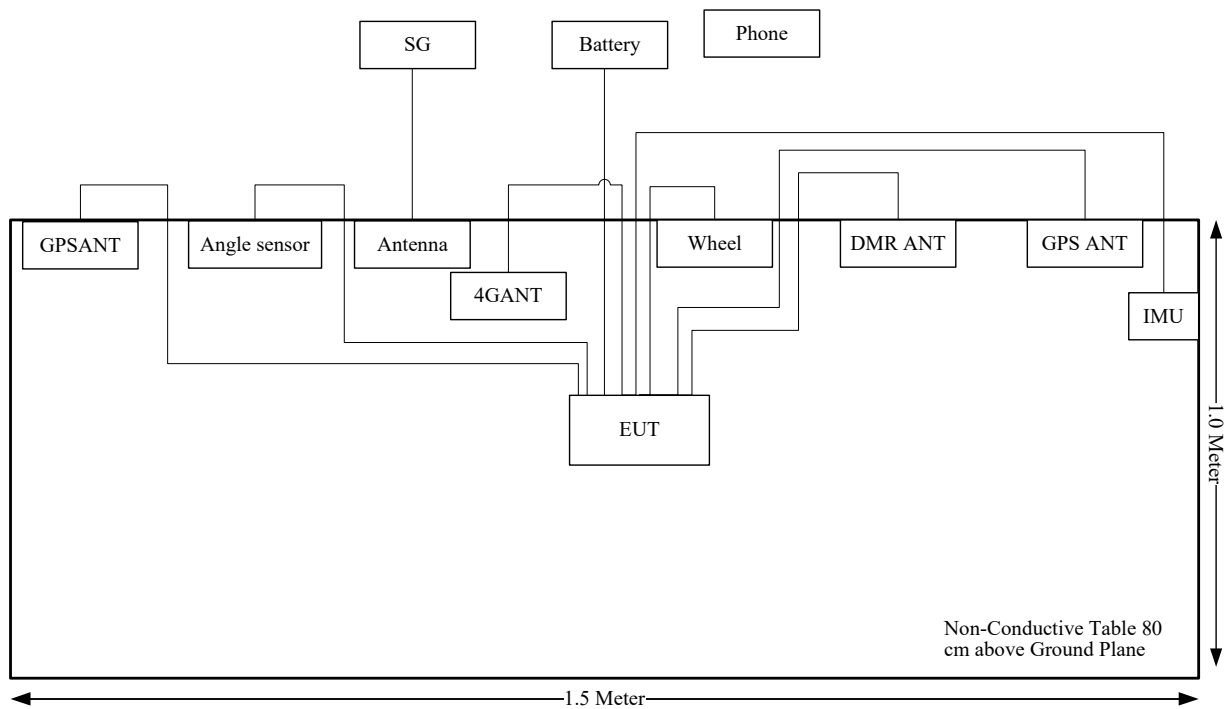

SUMMARY OF TEST RESULTS

Rules	Description of Test	Result
§15.247 (i) & §1.1310 & §2.1091	Maximum Permissible Exposure (MPE)	Compliance
RSS-102 Clause 4	Exposure Limits	Compliance
FCC §15.203, RSS-GEN Clause 6.8	Antenna Requirement	Compliance
FCC §15.207 (a); RSS-Gen Clause 8.8	AC Line Conducted Emissions	Not applicable*
FCC §15.205, §15.209, §15.247(d); RSS-247 Clause 5.5 RSS-Gen Clause 8.10	Spurious Emissions	Compliance
FCC §15.247 (a)(2); RSS-247 Clause 5.2 a) RSS-Gen Clause 6.7	6 dB Bandwidth and 99% Occupied Bandwidth	Compliance
FCC §15.247(b)(3); RSS-247 Clause 5.4 d)	Maximum Conducted Output Power	Compliance
FCC §15.247(d); RSS-247 Clause 5.5	100 kHz Bandwidth of Frequency Band Edge	Compliance
FCC §15.247(e) RSS-247 Clause 5.2 b)	Power Spectral Density	Compliance

Not applicable*: The device was used in vehicle environment.

FCC §15.247 (i) & §1.1310 & §2.1091 - MAXIMUM PERMISSIBLE EXPOSURE (MPE)

Applicable Standard

According to subpart 15.247(i) and subpart §1.1310, systems operating under the provisions of this section shall be operated in a manner that ensures that the public is not exposed to radio frequency energy level in excess of the Commission’s guidelines.

Limits for Maximum Permissible Exposure (MPE) (§1.1310, §2.1091)

(B) Limits for General Population/Uncontrolled Exposure				
Frequency Range (MHz)	Electric Field Strength (V/m)	Magnetic Field Strength (A/m)	Power Density (mW/cm²)	Averaging Time (minutes)
0.3–1.34	614	1.63	*(100)	30
1.34–30	824/f	2.19/f	*(180/f ²)	30
30–300	27.5	0.073	0.2	30
300–1500	/	/	f/1500	30
1500–100,000	/	/	1.0	30

f = frequency in MHz; * = Plane-wave equivalent power density;

According to §1.1310 and §2.1091 RF exposure is calculated.

Calculation formula

Prediction of power density at the distance of the applicable MPE limit

$S = PG/4\pi R^2$ = power density (in appropriate units, e.g. mW/cm²);

P = power input to the antenna (in appropriate units, e.g., mW);

G = power gain of the antenna in the direction of interest relative to an isotropic radiator, the power gain factor, is normally numeric gain;

R = distance to the center of radiation of the antenna (appropriate units, e.g., cm);

For simultaneously transmit system, the calculated power density should comply with:

$$\sum_i \frac{S_i}{S_{Limit,i}} \leq 1$$

Calculated Result

Operation Mode	Frequency (MHz)	Antenna Gain		Conducted Output Power including Tune-up Tolerance		Evaluation Distance (cm)	Power Density (mW/cm ²)	MPE Limit (mW/cm ²)
		(dBi)	(numeric)	(dBm)	(mW)			
Wi-Fi	2412	-0.4	0.91	26	398.11	20.00	0.07	1.00
GSM850	824.2	2	1.58	25.81	381.07	20.00	0.12	0.55
PCS1900	1850.2	2	1.58	22.81	190.99	20.00	0.06	1.00
WCDMA B2	1852.4	2	1.58	25	316.23	20.00	0.10	1.00
WCDMA B4	1712.4	2	1.58	25	316.23	20.00	0.10	1.00
WCDMA B5	826.4	2	1.58	25	316.23	20.00	0.10	0.55
LTE B2	1850.7	2	1.58	25	316.23	20.00	0.10	1.00
LTE B4	1710.7	2	1.58	25	316.23	20.00	0.10	1.00
LTE B5	824.7	2	1.58	25	316.23	20.00	0.10	0.55
LTE B7	2502.5	2	1.58	25	316.23	20.00	0.10	1.00
LTE B12	699.7	2	1.58	25	316.23	20.00	0.10	0.47
LTE B13	779.5	2	1.58	25	316.23	20.00	0.10	0.52
LTE B25	1850.7	2	1.58	25	316.23	20.00	0.10	1.00
LTE B26	814.7	2	1.58	25	316.23	20.00	0.10	0.54
LTE B38	2572.5	2	1.58	25	316.23	20.00	0.10	1.00
LTE B41	2498.5	2	1.58	25	316.23	20.00	0.10	1.00

Note: The device contains one LTE module (FCC ID: XMR201903EG25G). The output power of WWAN please refers to MPE report of LTE module.

MPE evaluation for simultaneous transmission:

Note: WLAN, WWAN can transmit simultaneously, MPE evaluation is as below formula:

$$PD1/Limit1 + PD2/Limit2 + \dots < 1, PD \text{ (Power Density)}$$

The worst case is as below:

$$MPE \text{ of WLAN} + MPE \text{ of WWAN} = 0.07/1.00 + 0.12/0.55 = 0.29 < 1.0$$

Conclusion: Compliance. The device meets FCC MPE at 20 cm distance

RSS-102 CLAUSE 4- EXPOSURE LIMITS

Applicable Standard

According to RSS-102 § (4):

Table 4: RF Field Strength Limits for Devices Used by the General Public (Uncontrolled Environment)				
Frequency Range (MHz)	Electric Field (V/m rms)	Magnetic Field (A/m rms)	Power Density (W/m ²)	Reference Period (minutes)
0.003-10 ²¹	83	90	-	Instantaneous*
0.1-10	-	0.73/ f	-	6**
1.1-10	87/ f ^{0.5}	-	-	6**
10-20	27.46	0.0728	2	6
20-48	58.07/ f ^{0.25}	0.1540/ f ^{0.25}	8.944/ f ^{0.5}	6
48-300	22.06	0.05852	1.291	6
300-6000	3.142 f ^{0.3417}	0.008335 f ^{0.3417}	0.02619 f ^{0.6834}	6
6000-15000	61.4	0.163	10	6
15000-150000	61.4	0.163	10	616000/ f ^{1.2}
150000-300000	0.158 f ^{0.5}	4.21 x 10 ⁻⁴ f ^{0.5}	6.67 x 10 ⁻⁵ f	616000/f ^{1.2}

Note: f is frequency in MHz.
 * Based on nerve stimulation (NS).
 ** Based on specific absorption rate (SAR).

Calculation formula

Prediction of power density at the distance of the applicable MPE limit

$S = PG/4\pi R^2 =$ power density (in appropriate units, e.g. mW/cm²);

P = power input to the antenna (in appropriate units, e.g., mW);

G = power gain of the antenna in the direction of interest relative to an isotropic radiator, the power gain factor, is normally numeric gain;

R = distance to the center of radiation of the antenna (appropriate units, e.g., cm);

For simultaneously transmit system, the calculated power density should comply with:

$$\sum_i \frac{S_i}{S_{Limit,i}} \leq 1$$

Calculated Result

Operation Mode	Frequency (MHz)	Antenna Gain		Conducted Output Power including Tune-up Tolerance		Evaluation Distance (cm)	Power Density (W/m ²)	MPE Limit (W/m ²)
		(dBi)	(numeric)	(dBm)	(mW)			
Wi-Fi	2412	-0.4	0.91	26	398.11	20.00	0.72	5.37
GSM850	824.2	2	1.58	25.81	381.07	20.00	1.20	2.58
PCS1900	1850.2	2	1.58	22.81	190.99	20.00	0.60	4.48
WCDMA B2	1852.4	2	1.58	25	316.23	20.00	1.00	4.48
WCDMA B4	1712.4	2	1.58	25	316.23	20.00	1.00	4.24
WCDMA B5	826.4	2	1.58	25	316.23	20.00	1.00	2.58
LTE B2	1850.7	2	1.58	25	316.23	20.00	1.00	4.48
LTE B4	1710.7	2	1.58	25	316.23	20.00	1.00	4.24
LTE B5	824.7	2	1.58	25	316.23	20.00	1.00	2.58
LTE B7	2502.5	2	1.58	25	316.23	20.00	1.00	5.50
LTE B12	699.7	2	1.58	25	316.23	20.00	1.00	2.30
LTE B13	779.5	2	1.58	25	316.23	20.00	1.00	2.47
LTE B25	1850.7	2	1.58	25	316.23	20.00	1.00	4.48
LTE B26 (824-849)	824.7	2	1.58	25	316.23	20.00	1.00	2.58
LTE B38	2572.5	2	1.58	25	316.23	20.00	1.00	5.60
LTE B41	2502.5	2	1.58	25	316.23	20.00	1.00	5.50

Note: The device contains one LTE module (IC: 10224A-201903EG25G). The output power of WWAN please refers to MPE report of LTE module.

MPE evaluation for simultaneous transmission:

Note: WLAN, WWAN can transmit simultaneously, MPE evaluation is as below formula:

$$PD1/Limit1 + PD2/Limit2 + \dots < 1, PD \text{ (Power Density)}$$

The worst case is as below:

$$MPE \text{ of WLAN} + MPE \text{ of WWAN} = 0.72/5.37 + 1.20/2.58 = 0.60 < 1.0$$

Conclusion: Compliance. The device meets MPE at 20 cm distance

FCC §15.203, RSS-GEN CLAUSE 6.8- ANTENNA REQUIREMENT

Applicable Standard

According to § 15.203, an intentional radiator shall be designed to ensure that no antenna other than that furnished by the responsible party shall be used with the device. The use of a permanently attached antenna or of an antenna that uses a unique coupling to the intentional radiator shall be considered sufficient to comply with the provisions of this section. The manufacturer may design the unit so that a broken antenna can be replaced by the user, but the user of a standard antenna jack or electrical connector is prohibited. The structure and application of the EUT were analyzed to determine compliance with section §15.203 of the rules. §15.203 state that the subject device must meet the following criteria:

- a. Antenna must be permanently attached to the unit.
- b. Antenna must use a unique type of connector to attach to the EUT.
- c. Unit must be professionally installed, and installer shall be responsible for verifying that the correct antenna is employed with the unit.

According to RSS-Gen §6.8, The applicant for equipment certification shall provide a list of all antenna types that may be used with the transmitter, where applicable (i.e. for transmitters with detachable antenna), indicating the maximum permissible antenna gain (in dBi) and the required impedance for each antenna. The test report shall demonstrate the compliance of the transmitter with the limit for maximum equivalent isotropically radiated power (e.i.r.p.) specified in the applicable RSS, when the transmitter is equipped with any antenna type, selected from this list.

For expediting the testing, measurements may be performed using only the antenna with highest gain of each combination of transmitter and antenna type, with the transmitter output power set at the maximum level. However, the transmitter shall comply with the applicable requirements under all operational conditions and when in combination with any type of antenna from the list provided in the test report (and in the notice to be included in the user manual, provided below).

When measurements at the antenna port are used to determine the RF output power, the effective gain of the device’s antenna shall be stated, based on a measurement or on data from the antenna’s manufacturer.

The test report shall state the RF power, output power setting and spurious emission measurements with each antenna type that is used with the transmitter being tested.

For licence-exempt equipment with detachable antennas, the user manual shall also contain the following notice in a conspicuous location:

This radio transmitter [enter the device’s ISED certification number] has been approved by Innovation, Science and Economic Development Canada to operate with the antenna types listed below, with the maximum permissible gain indicated. Antenna types not included in this list that have a gain greater than the maximum gain indicated for any type listed are strictly prohibited for use with this device.

Immediately following the above notice, the manufacturer shall provide a list of all antenna types which can be used with the transmitter, indicating the maximum permissible antenna gain (in dBi) and the required impedance for each antenna type.

Antenna Connector Construction

The EUT has one internal antenna arrangement for WIFI, fulfill the requirement of this section. Please refer to the EUT photos.

Antenna Type	Input Impedance (Ohm)	Antenna Gain /Frequency Range
FPC	50	-0.4dBi/2.4~2.5GHz

Result: Compliance.

FCC §15.209, §15.205 & §15.247(d), RSS-247 CLAUSE 5.5, RSS-GEN CLAUSE 8.10 - SPURIOUS EMISSIONS

Applicable Standard

FCC §15.247 (d); §15.209; §15.205; RSS-247 §5.5, RSS-GEN §8.10.

Test System Setup

Below 1GHz:

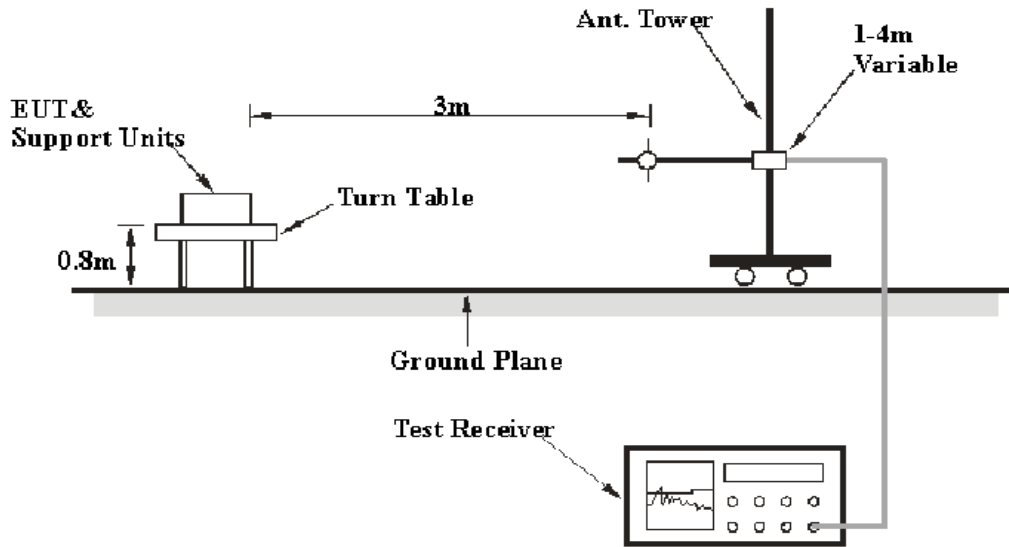

Above 1GHz:

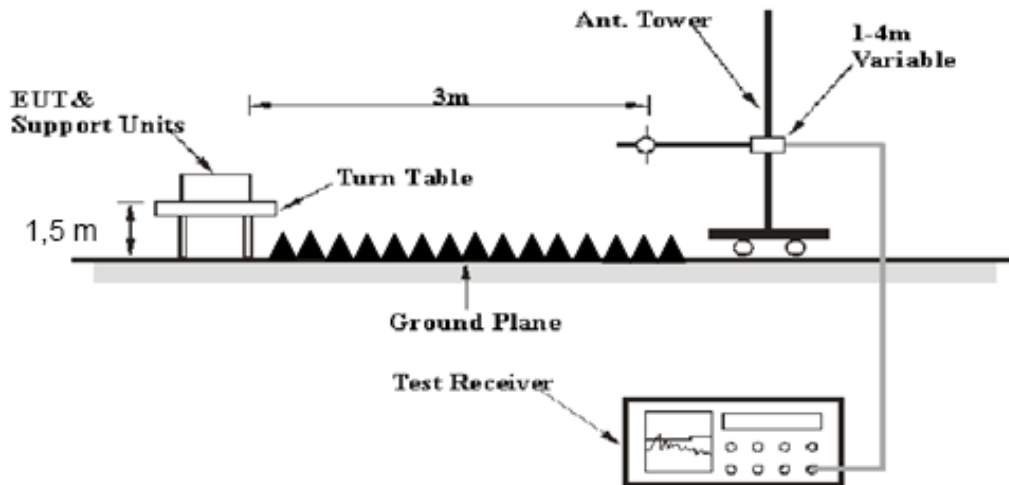

The radiated emission below 1GHz tests were performed in the 10 meters chamber test site, above 1GHz tests were performed in the 3 meters chamber test site B, using the setup accordance with the ANSI C63.10-2013. The specification used was the FCC 15.209, and FCC 15.247 limits.

The spacing between the peripherals was 10 cm.

EMI Test Receiver & Spectrum Analyzer Setup

The system was investigated from 30 MHz to 25 GHz.

During the radiated emission test, the EMI test receiver & Spectrum Analyzer Setup were set with the following configurations:

30MHz-1000MHz:

Measurement	RBW	Video B/W	IF B/W
QP	120 kHz	300 kHz	120kHz

1GHz- 25GHz:

Measurement	Duty cycle	RBW	Video B/W
PK	Any	1MHz	3 MHz
AV	>98%	1MHz	10 Hz
	<98%	1MHz	1/T

Note: T is minimum transmission duration

If the maximized peak measured value complies with under the QP/Average limit more than 6dB, then it is unnecessary to perform an QP/Average measurement.

Test Procedure

Maximizing procedure was performed on the highest emissions to ensure that the EUT complied with all installation combinations.

Data was recorded in Quasi-peak detection mode for frequency range of 30 MHz-1 GHz, peak and Average detection modes for frequencies above 1 GHz.

Corrected Amplitude & Margin Calculation

The Corrected Amplitude is calculated by adding the Antenna Factor and Cable Loss, and subtracting the Amplifier Gain from the Meter Reading. The basic equation is as follows:

$$\text{Corrected Amplitude} = \text{Meter Reading} + \text{Antenna Factor} + \text{Cable Loss} - \text{Amplifier Gain}$$

The “Margin” column of the following data tables indicates the degree of compliance with the applicable limit. For example, a margin of 7dB means the emission is 7dB below the limit. The equation for margin calculation is as follows:

$$\text{Margin} = \text{Limit} - \text{Corrected Amplitude}$$

Test Equipment List

Manufacturer	Description	Model	Serial Number	Calibration Date	Calibration Due Date
Radiation Below 1GHz Test					
Sunol Sciences	Antenna	JB3	A060611-2	2020-08-25	2023-08-25
R&S	EMI Test Receiver	ESCI	100224	2020-09-12	2021-09-12
Unknown	Coaxial Cable	C-NJNJ-50	C-1000-01	2020-09-05	2021-09-05
Unknown	Coaxial Cable	C-NJNJ-50	C-0400-02	2020-09-05	2021-09-05
Unknown	Coaxial Cable	C-NJNJ-50	C-0530-01	2020-09-24	2021-09-24
Sonoma	Amplifier	310N	185914	2020-10-13	2021-10-13
Farad	Test Software	EZ-EMC	V1.1.4.2	N/A	N/A
Radiation Above 1GHz Test					
ETS-Lindgren	Horn Antenna	3115	9912-5985	2020-10-13	2023-10-12
Ducommun Technologies	Horn Antenna	ARH-4223-02	1007726-01 1304	2020-12-05	2023-12-04
R&S	Spectrum Analyzer	FSP 38	100478	2020-09-07	2021-09-07
HUBER+SUHNER	Coaxial Cable	SUCOFLEX 126EA	MY369/26/26EA	2020-09-25	2021-09-25
Mini	Pre-amplifier	ZVA-183-S+	5969001149	2020-09-05	2021-09-05
Quinstar	Amplifier	QLW-18405536-JO	15964001001	2020-09-27	2021-09-27
Farad	Test Software	EZ-EMC	V1.1.4.2	N/A	N/A

* Statement of Traceability: Bay Area Compliance Laboratories Corp. (Dongguan) attests that all calibrations have been performed, traceable to National Primary Standards and International System of Units (SI).

Test Data

Environmental Conditions

Temperature:	26.0 °C
Relative Humidity:	58%
ATM Pressure:	100.3kPa
Tester:	Burt Hu, Joker Chen
Test Date:	2021-07-20, 2021-07-15

Test Result: Compliance, please Refer to the following data

Test Mode: Transmitting

1) 30MHz-1GHz (802.11b mode middle channel was the worst)

Horizontal:

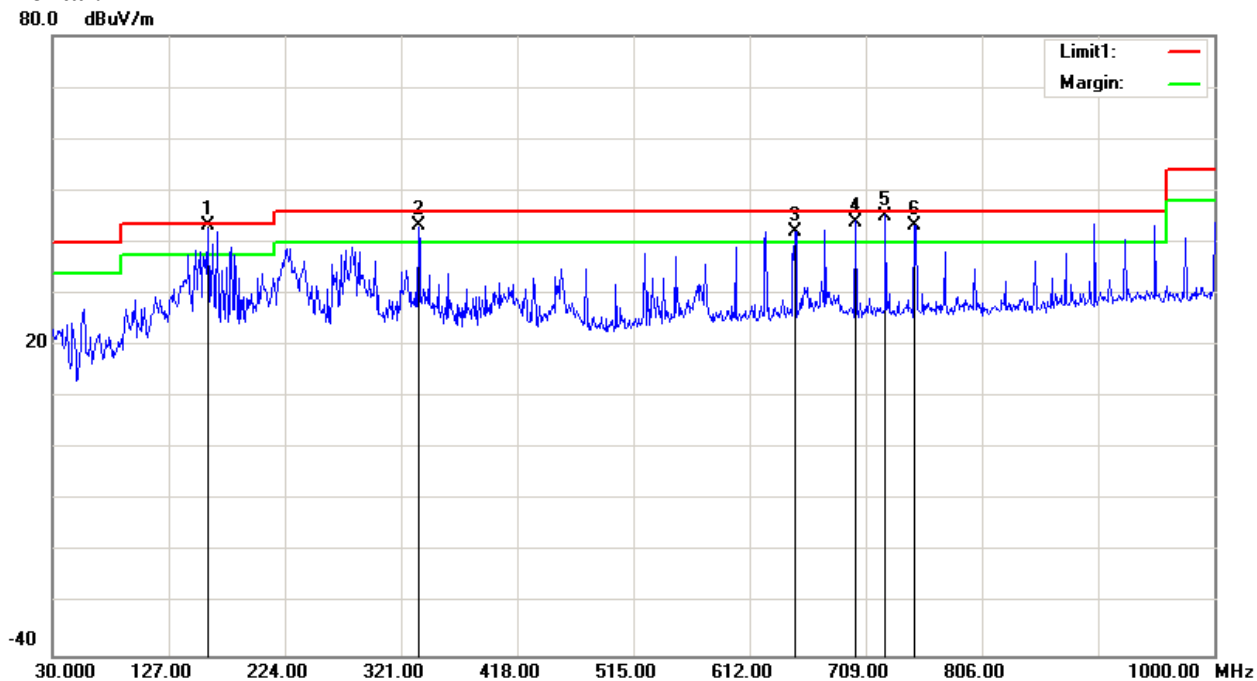

Frequency (MHz)	Receiver Reading (dBuV)	Detector	Correction Factor (dB/m)	Cord. Amp. (dBuV/m)	Limit (dBuV/m)	Margin (dB)
159.9800	52.81	QP	-9.41	43.40	43.50	0.10
335.5500	50.06	QP	-6.86	43.20	46.00	2.80
649.8300	42.45	QP	-0.45	42.00	46.00	4.00
700.2700	43.94	QP	0.06	44.00	46.00	2.00
725.4900	44.53	QP	0.67	45.20	46.00	0.80
749.7400	42.66	QP	0.54	43.20	46.00	2.80

Vertical:

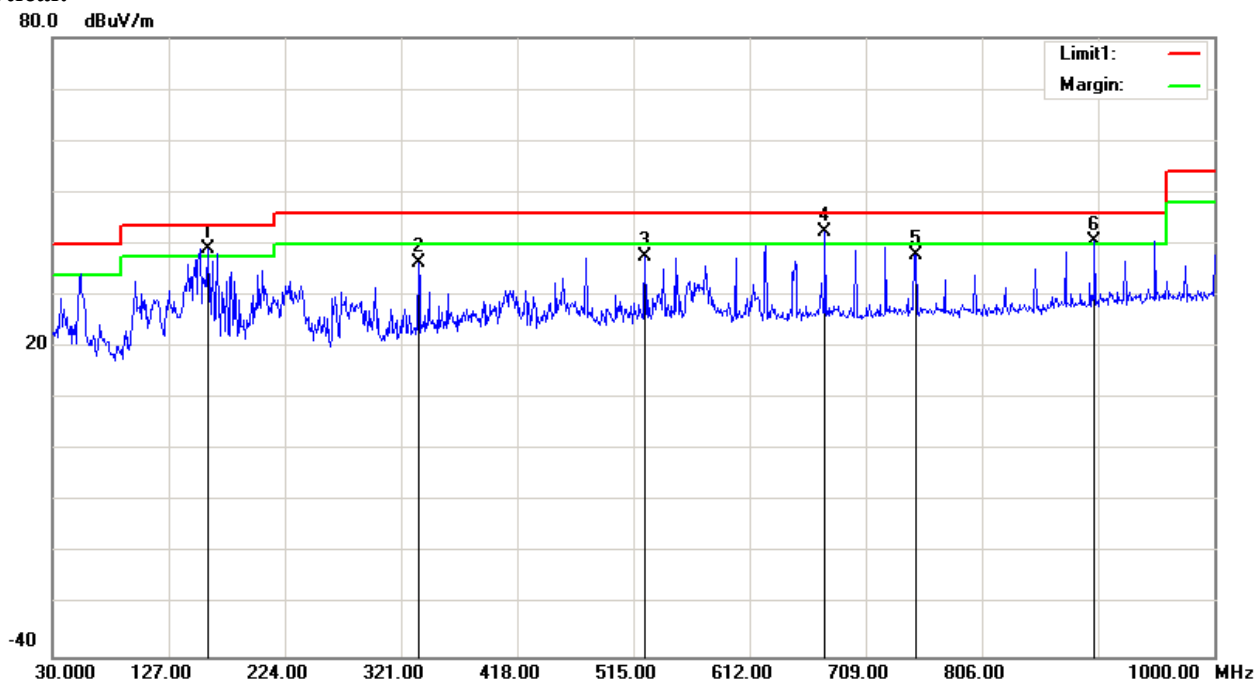

Frequency (MHz)	Receiver Reading (dBuV)	Detector	Correction Factor (dB/m)	Cord. Amp. (dBuV/m)	Limit (dBuV/m)	Margin (dB)
159.9800	48.41	QP	-9.41	39.00	43.50	4.50
335.5500	43.35	peak	-6.86	36.49	46.00	9.51
524.7000	40.08	peak	-2.51	37.57	46.00	8.43
675.0500	42.56	QP	-0.06	42.50	46.00	3.50
750.7100	37.36	peak	0.56	37.92	46.00	8.08
900.0900	37.17	QP	3.43	40.60	46.00	5.40

2) 1-25GHz

802.11b Mode:

Frequency (MHz)	Receiver		Rx Antenna		Cable loss (dB)	Amplifier Gain (dB)	Corrected Amplitude (dBµV/m)	Limit (dBµV/m)	Margin (dB)
	Reading (dBµV)	Detector	Polar (H/V)	Factor (dB/m)					
Low Channel: 2412 MHz									
2412.00	77.19	PK	H	28.12	2.50	0.00	107.81	N/A	N/A
2412.00	63.15	AV	H	28.12	2.50	0.00	93.77	N/A	N/A
2412.00	75.35	PK	V	28.12	2.50	0.00	105.97	N/A	N/A
2412.00	61.62	AV	V	28.12	2.50	0.00	92.24	N/A	N/A
2390.00	28.77	PK	H	28.08	2.50	0.00	59.35	74.00	14.65
2390.00	15.17	AV	H	28.08	2.50	0.00	45.75	54.00	8.25
4824.00	36.24	PK	H	32.92	3.59	27.41	45.34	74.00	28.66
4824.00	24.65	AV	H	32.92	3.59	27.41	33.75	54.00	20.25
7236.00	36.05	PK	H	35.62	4.67	27.22	49.12	74.00	24.88
7236.00	24.39	AV	H	35.62	4.67	27.22	37.46	54.00	16.54
1365.40	49.84	PK	V	24.29	1.94	27.77	48.30	74.00	25.70
1365.40	42.33	AV	V	24.29	1.94	27.77	40.79	54.00	13.21
Middle Channel: 2437 MHz									
2437.00	76.69	PK	H	28.17	2.51	0.00	107.37	N/A	N/A
2437.00	62.98	AV	H	28.17	2.51	0.00	93.66	N/A	N/A
2437.00	75.72	PK	V	28.17	2.51	0.00	106.40	N/A	N/A
2437.00	61.77	AV	V	28.17	2.51	0.00	92.45	N/A	N/A
4874.00	35.97	PK	H	33.00	3.58	27.54	45.01	74.00	28.99
4874.00	24.56	AV	H	33.00	3.58	27.54	33.60	54.00	20.40
7311.00	36.30	PK	H	35.78	4.65	27.28	49.45	74.00	24.55
7311.00	24.95	AV	H	35.78	4.65	27.28	38.10	54.00	15.90
1365.40	50.29	PK	V	24.29	1.94	27.77	48.75	74.00	25.25
1365.40	43.07	AV	V	24.29	1.94	27.77	41.53	54.00	12.47
High Channel: 2462 MHz									
2462.00	77.46	PK	H	28.22	2.52	0.00	108.20	N/A	N/A
2462.00	63.40	AV	H	28.22	2.52	0.00	94.14	N/A	N/A
2462.00	76.64	PK	V	28.22	2.52	0.00	107.38	N/A	N/A
2462.00	62.37	AV	V	28.22	2.52	0.00	93.11	N/A	N/A
2483.50	28.76	PK	H	28.27	2.53	0.00	59.56	74.00	14.44
2483.50	15.12	AV	H	28.27	2.53	0.00	45.92	54.00	8.08
4924.00	36.95	PK	H	33.08	3.58	27.51	46.10	74.00	27.90
4924.00	25.55	AV	H	33.08	3.58	27.51	34.70	54.00	19.30
7386.00	36.03	PK	H	35.95	4.62	27.18	49.42	74.00	24.58
7386.00	24.37	AV	H	35.95	4.62	27.18	37.76	54.00	16.24
1365.40	51.16	PK	V	24.29	1.94	27.77	49.62	74.00	24.38
1365.40	44.18	AV	V	24.29	1.94	27.77	42.64	54.00	11.36

802.11g Mode:

Frequency (MHz)	Receiver		Rx Antenna		Cable loss (dB)	Amplifier Gain (dB)	Corrected Amplitude (dBµV/m)	Limit (dBµV/m)	Margin (dB)
	Reading (dBµV)	Detector	Polar (H/V)	Factor (dB/m)					
Low Channel: 2412 MHz									
2412.00	76.07	PK	H	28.12	2.50	0.00	106.69	N/A	N/A
2412.00	64.84	AV	H	28.12	2.50	0.00	95.46	N/A	N/A
2412.00	74.47	PK	V	28.12	2.50	0.00	105.09	N/A	N/A
2412.00	63.41	AV	V	28.12	2.50	0.00	94.03	N/A	N/A
2386.00	38.47	PK	H	28.07	2.50	0.00	69.04	74.00	4.96
2386.00	18.50	AV	H	28.07	2.50	0.00	49.07	54.00	4.93
4824.00	36.53	PK	H	32.92	3.59	27.41	45.63	74.00	28.37
4824.00	25.23	AV	H	32.92	3.59	27.41	34.33	54.00	19.67
7236.00	36.00	PK	H	35.62	4.67	27.22	49.07	74.00	24.93
7236.00	24.20	AV	H	35.62	4.67	27.22	37.27	54.00	16.73
1365.40	50.40	PK	V	24.29	1.94	27.77	48.86	74.00	25.14
1365.40	43.42	AV	V	24.29	1.94	27.77	41.88	54.00	12.12
Middle Channel: 2437 MHz									
2437.00	75.13	PK	H	28.17	2.51	0.00	105.81	N/A	N/A
2437.00	63.37	AV	H	28.17	2.51	0.00	94.05	N/A	N/A
2437.00	73.76	PK	V	28.17	2.51	0.00	104.44	N/A	N/A
2437.00	62.15	AV	V	28.17	2.51	0.00	92.83	N/A	N/A
4874.00	36.55	PK	H	33.00	3.58	27.54	45.59	74.00	28.41
4874.00	24.97	AV	H	33.00	3.58	27.54	34.01	54.00	19.99
7311.00	35.12	PK	H	35.78	4.65	27.28	48.27	74.00	25.73
7311.00	23.28	AV	H	35.78	4.65	27.28	36.43	54.00	17.57
1365.40	50.89	PK	V	24.29	1.94	27.77	49.35	74.00	24.65
1365.40	43.91	AV	V	24.29	1.94	27.77	42.37	54.00	11.63
High Channel: 2462 MHz									
2462.00	73.75	PK	H	28.22	2.52	0.00	104.49	N/A	N/A
2462.00	62.15	AV	H	28.22	2.52	0.00	92.89	N/A	N/A
2462.00	72.44	PK	V	28.22	2.52	0.00	103.18	N/A	N/A
2462.00	60.73	AV	V	28.22	2.52	0.00	91.47	N/A	N/A
2483.50	33.94	PK	H	28.27	2.53	0.00	64.74	74.00	9.26
2483.50	18.03	AV	H	28.27	2.53	0.00	48.83	54.00	5.17
4924.00	36.39	PK	H	33.08	3.58	27.51	45.54	74.00	28.46
4924.00	25.11	AV	H	33.08	3.58	27.51	34.26	54.00	19.74
7386.00	35.97	PK	H	35.95	4.62	27.18	49.36	74.00	24.64
7386.00	24.58	AV	H	35.95	4.62	27.18	37.97	54.00	16.03
1365.40	50.05	PK	V	24.29	1.94	27.77	48.51	74.00	25.49
1365.40	42.90	AV	V	24.29	1.94	27.77	41.36	54.00	12.64

802.11n ht20 Mode:

Frequency (MHz)	Receiver		Rx Antenna		Cable loss (dB)	Amplifier Gain (dB)	Corrected Amplitude (dBµV/m)	Limit (dBµV/m)	Margin (dB)
	Reading (dBµV)	Detector	Polar (H/V)	Factor (dB/m)					
Low Channel: 2412 MHz									
2412.00	74.87	PK	H	28.12	2.50	0.00	105.49	N/A	N/A
2412.00	64.03	AV	H	28.12	2.50	0.00	94.65	N/A	N/A
2412.00	73.04	PK	V	28.12	2.50	0.00	103.66	N/A	N/A
2412.00	62.17	AV	V	28.12	2.50	0.00	92.79	N/A	N/A
2386.50	42.81	PK	H	28.07	2.50	0.00	73.38	74.00	0.62
2386.50	18.71	AV	H	28.07	2.50	0.00	49.28	54.00	4.72
4824.00	37.57	PK	H	32.92	3.59	27.41	46.67	74.00	27.33
4824.00	25.29	AV	H	32.92	3.59	27.41	34.39	54.00	19.61
7236.00	36.11	PK	H	35.62	4.67	27.22	49.18	74.00	24.82
7236.00	24.52	AV	H	35.62	4.67	27.22	37.59	54.00	16.41
1365.40	48.42	PK	V	24.29	1.94	27.77	46.88	74.00	27.12
1365.40	41.13	AV	V	24.29	1.94	27.77	39.59	54.00	14.41
Middle Channel: 2437 MHz									
2437.00	73.73	PK	H	28.17	2.51	0.00	104.41	N/A	N/A
2437.00	62.54	AV	H	28.17	2.51	0.00	93.22	N/A	N/A
2437.00	71.88	PK	V	28.17	2.51	0.00	102.56	N/A	N/A
2437.00	61.03	AV	V	28.17	2.51	0.00	91.71	N/A	N/A
4874.00	37.21	PK	H	33.00	3.58	27.54	46.25	74.00	27.75
4874.00	24.69	AV	H	33.00	3.58	27.54	33.73	54.00	20.27
7311.00	36.15	PK	H	35.78	4.65	27.28	49.30	74.00	24.70
7311.00	24.55	AV	H	35.78	4.65	27.28	37.70	54.00	16.30
1365.40	48.62	PK	V	24.29	1.94	27.77	47.08	74.00	26.92
1365.40	41.35	AV	V	24.29	1.94	27.77	39.81	54.00	14.19
High Channel: 2462 MHz									
2462.00	72.10	PK	H	28.22	2.52	0.00	102.84	N/A	N/A
2462.00	61.02	AV	H	28.22	2.52	0.00	91.76	N/A	N/A
2462.00	70.02	PK	V	28.22	2.52	0.00	100.76	N/A	N/A
2462.00	59.19	AV	V	28.22	2.52	0.00	89.93	N/A	N/A
2483.50	32.15	PK	H	28.27	2.53	0.00	62.95	74.00	11.05
2483.50	17.81	AV	H	28.27	2.53	0.00	48.61	54.00	5.39
4924.00	36.72	PK	H	33.08	3.58	27.51	45.87	74.00	28.13
4924.00	24.34	AV	H	33.08	3.58	27.51	33.49	54.00	20.51
7386.00	35.90	PK	H	35.95	4.62	27.18	49.29	74.00	24.71
7386.00	24.36	AV	H	35.95	4.62	27.18	37.75	54.00	16.25
1365.40	49.13	PK	V	24.29	1.94	27.77	47.59	74.00	26.41
1365.40	41.58	AV	V	24.29	1.94	27.77	40.04	54.00	13.96

3) Test plots (802.11b Low channel was the worst)

Horizontal:

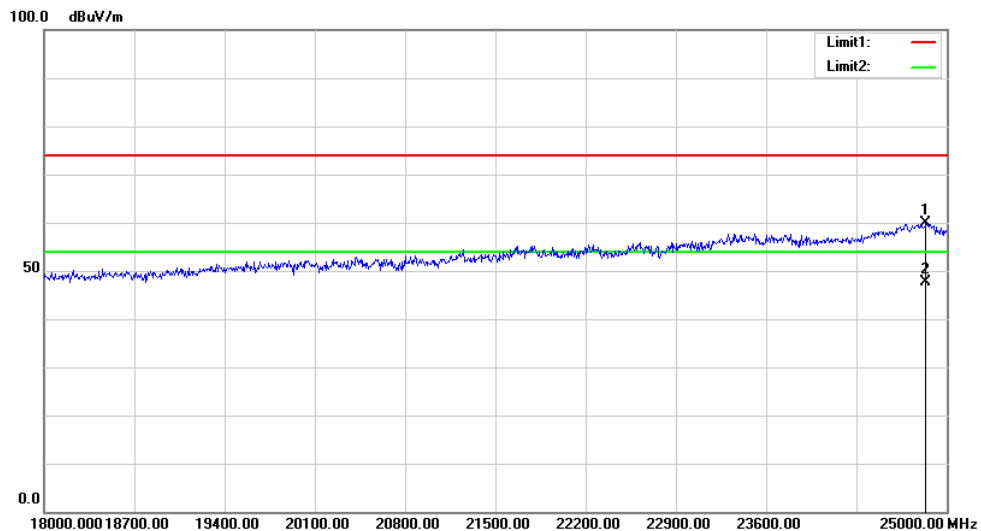
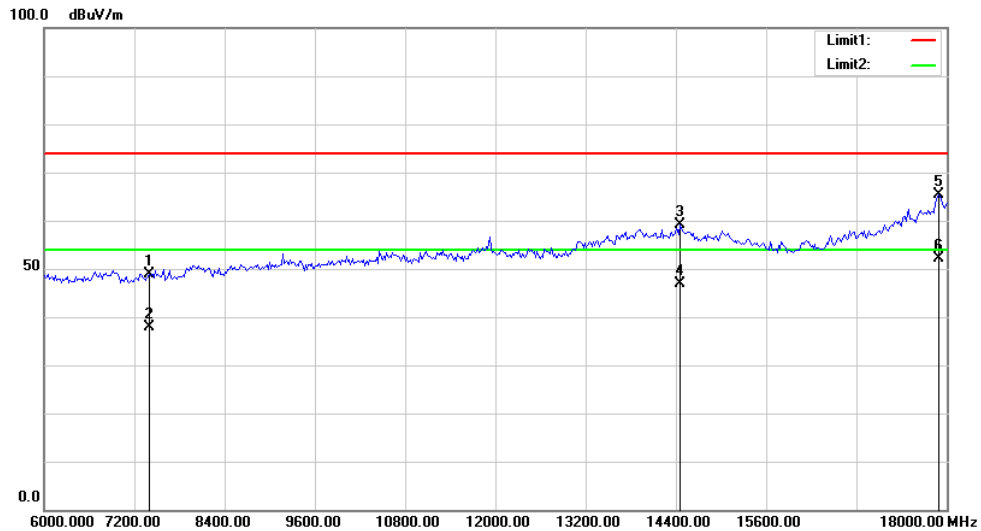
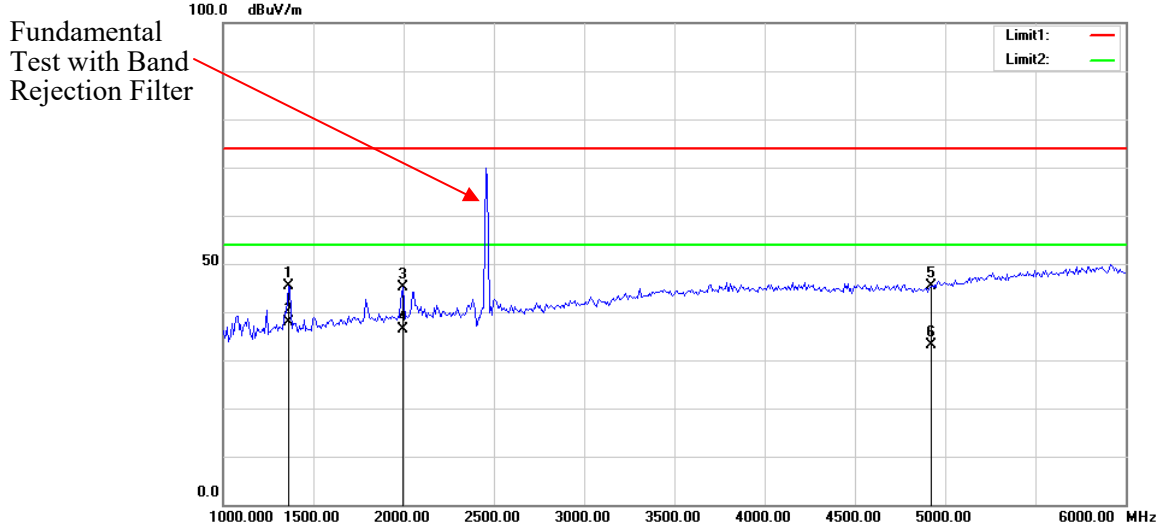

Vertical:

Fundamental Test with Band Rejection Filter

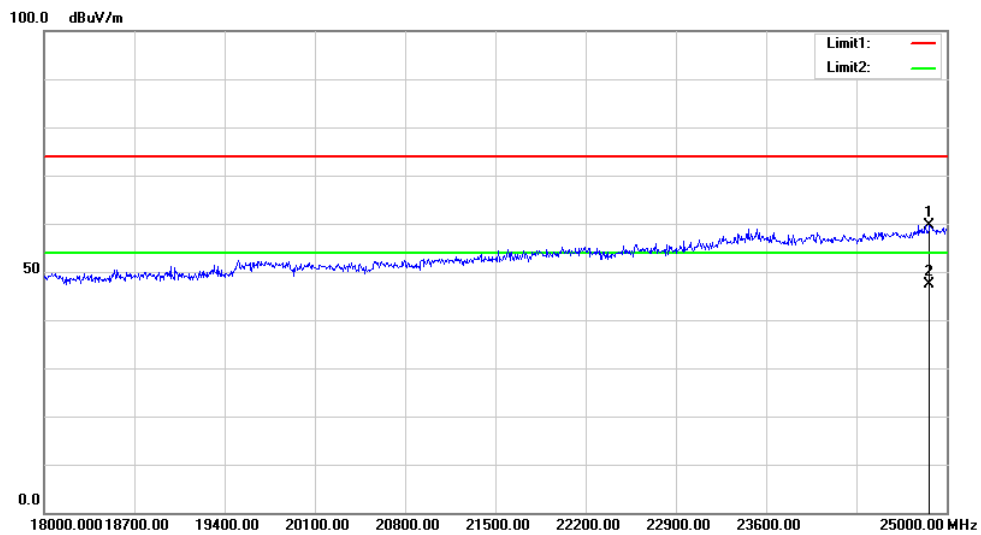
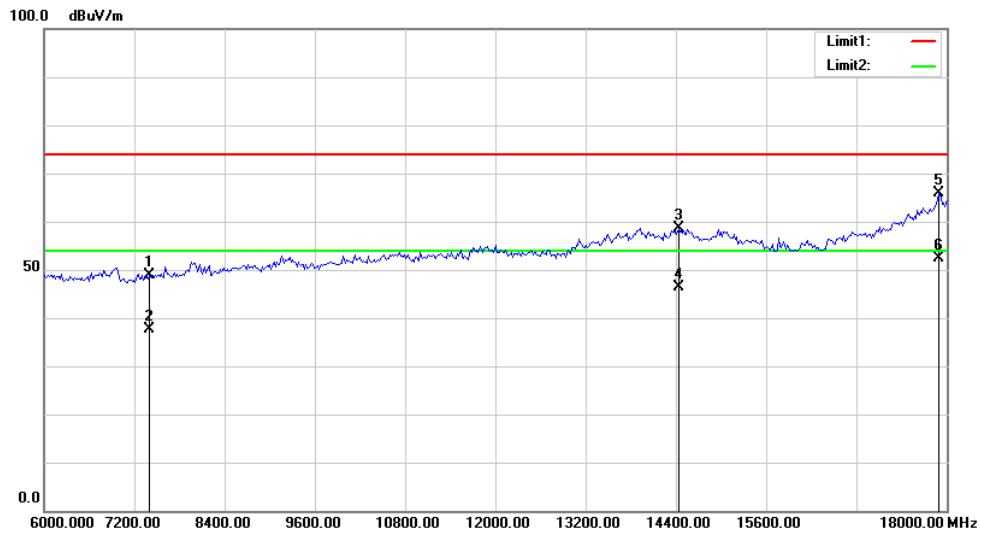
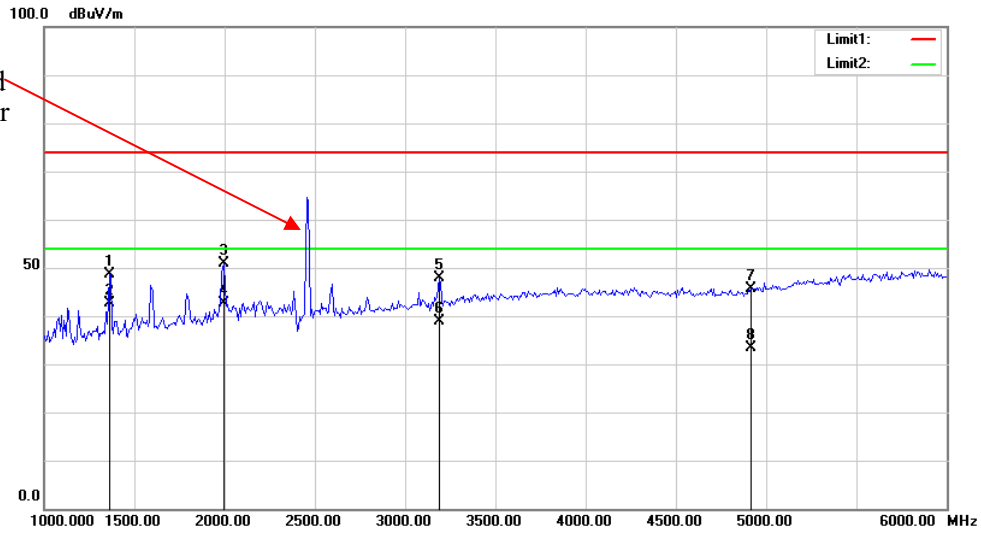

FCC §15.247(a) (2), RSS-GEN CLAUSE 6.7– 6 dB EMISSION BANDWIDTH AND 99% OCCUPIED BANDWIDTH

Applicable Standard

According to FCC §15.247(a) (2)

Systems using digital modulation techniques may operate in the 902–928 MHz, 2400–2483.5 MHz, and 5725–5850 MHz bands. The minimum 6 dB bandwidth shall be at least 500 kHz.

According to RSS-247 §5.2 a)

The minimum 6 dB bandwidth shall be 500 kHz.

According to RSS-Gen §6.7

The occupied bandwidth or the “99% emission bandwidth” is defined as the frequency range between two points, one above and the other below the carrier frequency, within which 99% of the total transmitted power of the fundamental transmitted emission is contained. The occupied bandwidth shall be reported for all equipment in addition to the specified bandwidth required in the applicable RSSs.

In some cases, the “x dB bandwidth” is required, which is defined as the frequency range between two points, one at the lowest frequency below and one at the highest frequency above the carrier frequency, at which the maximum power level of the transmitted emission is attenuated x dB below the maximum in-band power level of the modulated signal, where the two points are on the outskirts of the in-band emission.

The following conditions shall be observed for measuring the occupied bandwidth and x dB bandwidth:

- The transmitter shall be operated at its maximum carrier power measured under normal test conditions.
- The span of the spectrum analyzer shall be set large enough to capture all products of the modulation process, including the emission skirts, around the carrier frequency, but small enough to avoid having other emissions (e.g. on adjacent channels) within the span.
- The detector of the spectrum analyzer shall be set to “Sample”. However, a peak, or peak hold, may be used in place of the sampling detector since this usually produces a wider bandwidth than the actual bandwidth (worst-case measurement). Use of a peak hold (or “Max Hold”) may be necessary to determine the occupied / x dB bandwidth if the device is not transmitting continuously.
- The resolution bandwidth (RBW) shall be in the range of 1% to 5% of the actual occupied / x dB bandwidth and the video bandwidth (VBW) shall not be smaller than three times the RBW value. Video averaging is not permitted.

Note: It may be necessary to repeat the measurement a few times until the RBW and VBW are in compliance with the above requirement.

For the 99% emission bandwidth, the trace data points are recovered and directly summed in linear power level terms. The recovered amplitude data points, beginning at the lowest frequency, are placed in a running sum until 0.5% of the total is reached, and that frequency recorded. The process is repeated for the highest frequency data points (starting at the highest frequency, at the right side of the span, and going down in frequency). This frequency is then recorded. The difference between the two recorded frequencies is the occupied bandwidth (or the 99% emission bandwidth).

Test Procedure

- a) Set RBW = 100 kHz.
- b) Set the video bandwidth (VBW) ≥ 3×RBW.
- c) Detector = Peak.
- d) Trace mode = max hold.
- e) Sweep = auto couple.
- f) Allow the trace to stabilize.
- g) Measure the maximum width of the emission that is constrained by the frequencies associated with the two outermost amplitude points (upper and lower frequencies) that are attenuated by 6 dB relative to the maximum level measured in the fundamental emission.

99% Occupied bandwidth test:

Use Occupied bandwidth test function, measure the 99% Occupied bandwidth.
Repeat above procedures until all frequencies measured were complete.

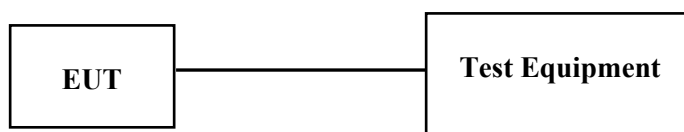

Test Equipment List

Manufacturer	Description	Model	Serial Number	Calibration Date	Calibration Due Date
R&S	Spectrum Analyzer	FSU 26	200256	2020-07-07	2021-07-07
E-Microwave	Coaxial Attenuators	EMCA10-5RN-6	OE01203239	2020-09-06	2021-09-06
Unknown	Coaxial Cable	C-SJ00-0010	C0010/01	Each time	N/A

** Statement of Traceability: Bay Area Compliance Laboratories Corp. (Dongguan) attests that all calibrations have been performed, traceable to National Primary Standards and International System of Units (SI).*

Test Data

Environmental Conditions

Temperature:	24.2 °C
Relative Humidity:	50 %
ATM Pressure:	100.1 kPa
Tester:	Wayne Wei
Test Date:	2021-03-29

Test Mode: Transmitting

Test Result: Compliance. Please refer to following tables and plots.

Test mode	Frequency (MHz)	6 dB Bandwidth (MHz)	99% Occupied Bandwidth (MHz)	Limit (MHz)
802.11 b	2412	9.520	13.840	≥0.5
	2437	9.040	13.840	≥0.5
	2462	8.480	13.840	≥0.5
802.11 g	2412	15.600	16.640	≥0.5
	2437	15.360	16.560	≥0.5
	2462	15.200	16.640	≥0.5
802.11n ht20	2412	15.440	17.920	≥0.5
	2437	15.200	18.000	≥0.5
	2462	15.200	17.920	≥0.5

6dB Bandwidth:

802.11b Low Channel

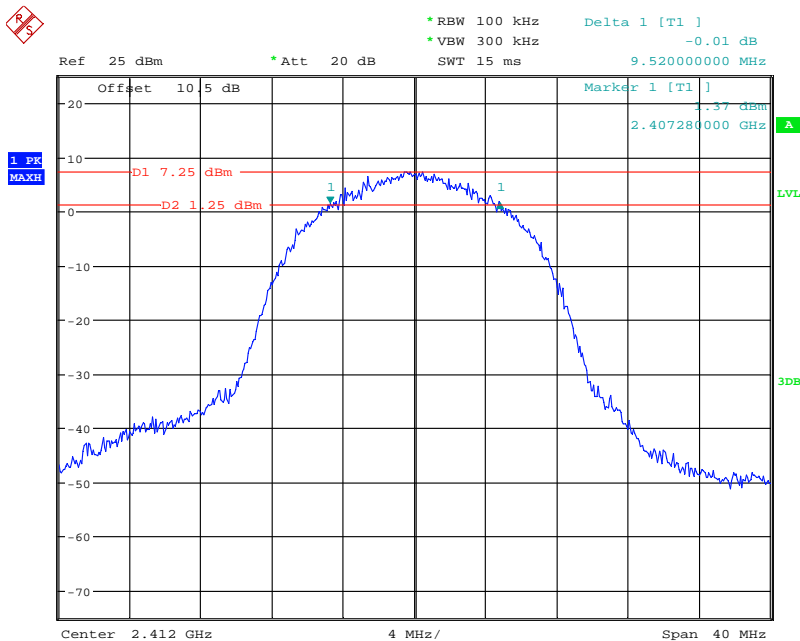

Date: 29.MAR.2021 12:53:07

802.11b Middle Channel

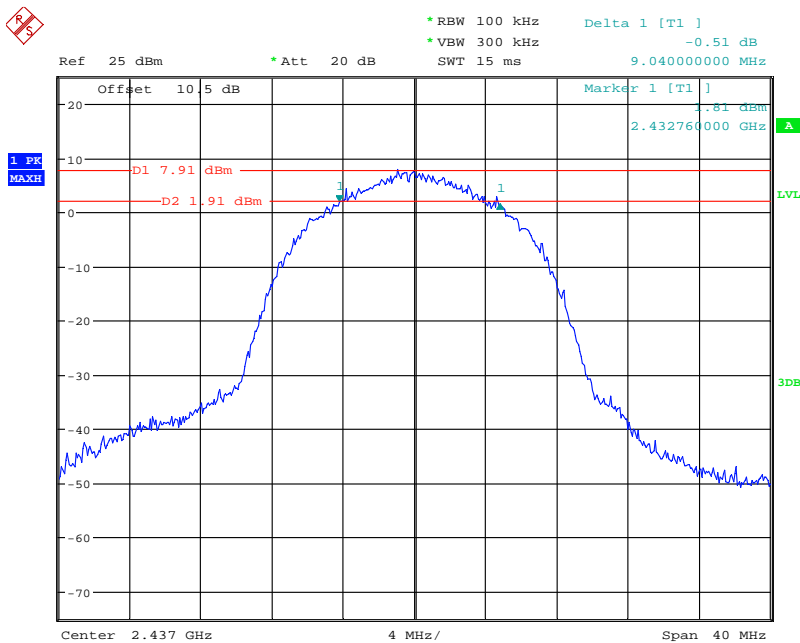

Date: 29.MAR.2021 12:54:09

802.11b High Channel

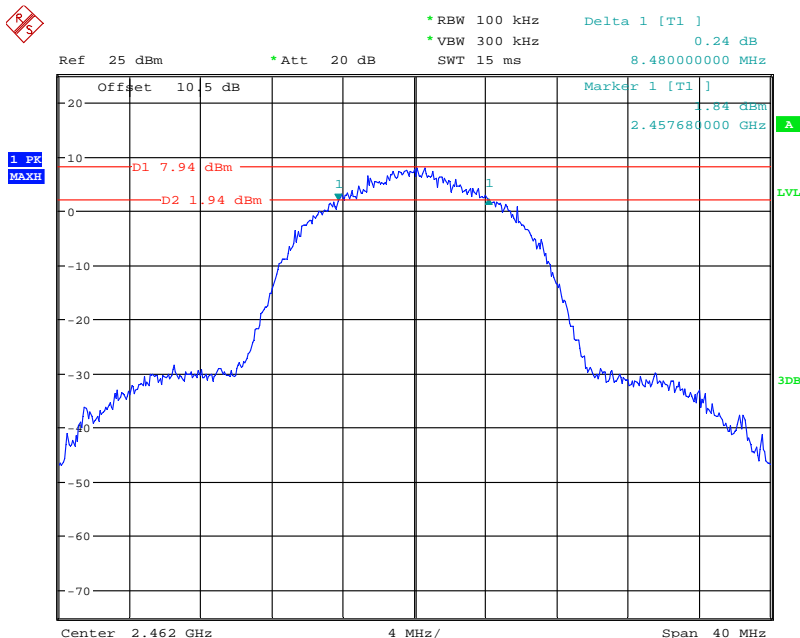

Date: 29.MAR.2021 12:42:30

802.11g Low Channel

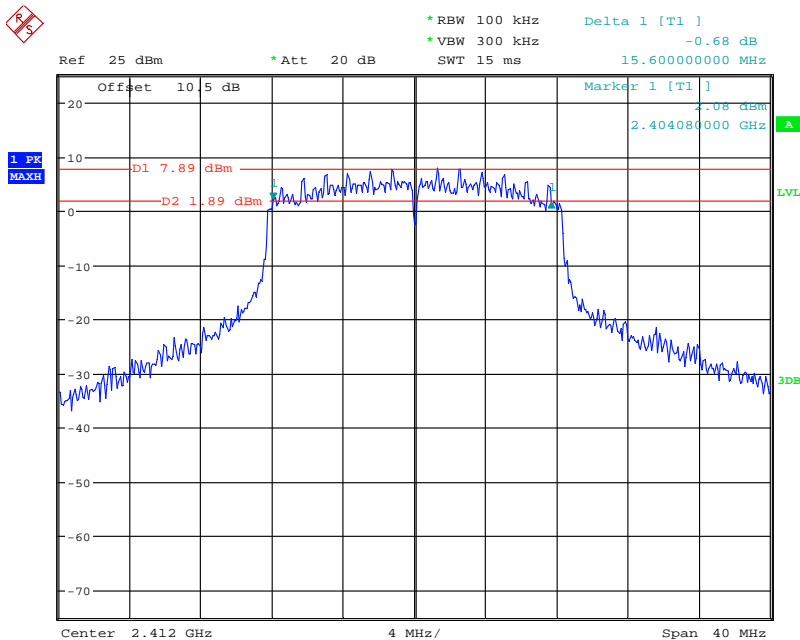

Date: 29.MAR.2021 12:46:45

802.11g Middle Channel

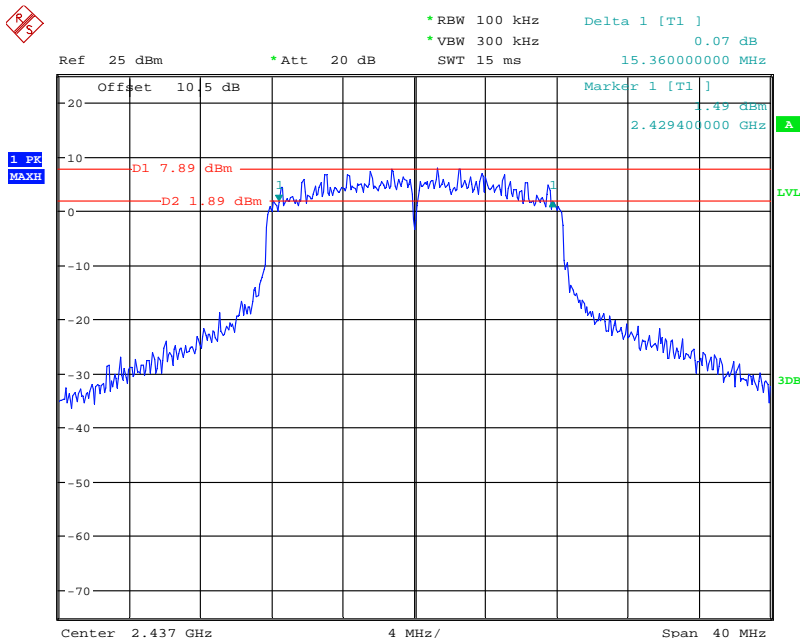

Date: 29.MAR.2021 12:08:56

802.11g High Channel

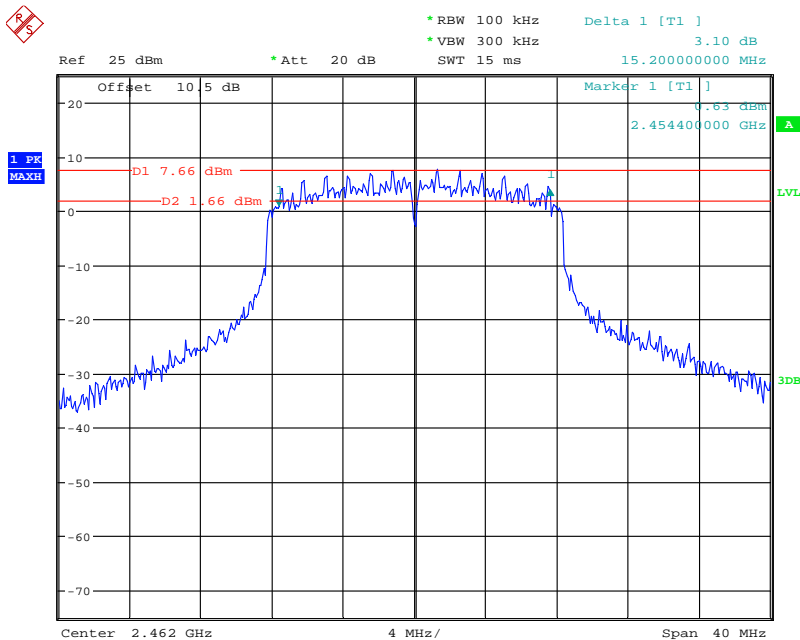

Date: 29.MAR.2021 12:10:19

802.11n ht20 Low Channel

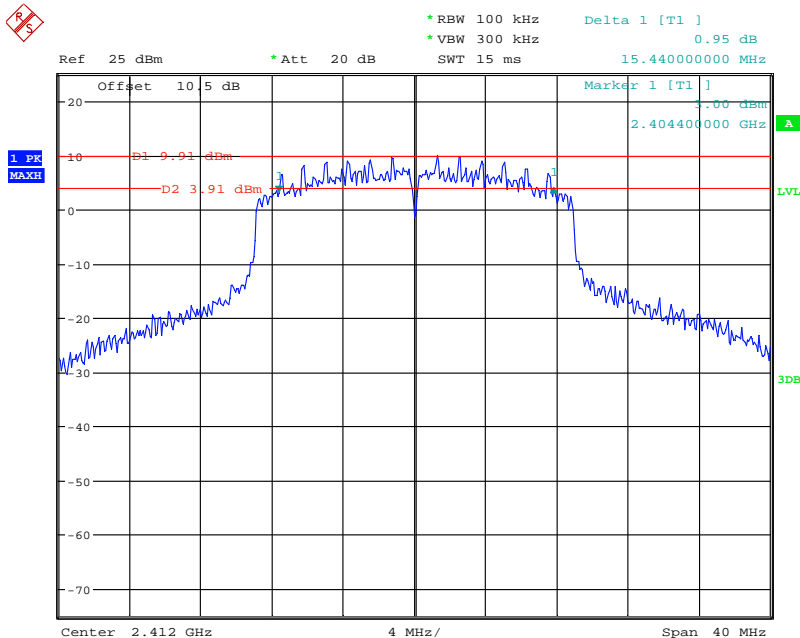

Date: 29.MAR.2021 12:56:11

802.11n ht20 Middle Channel

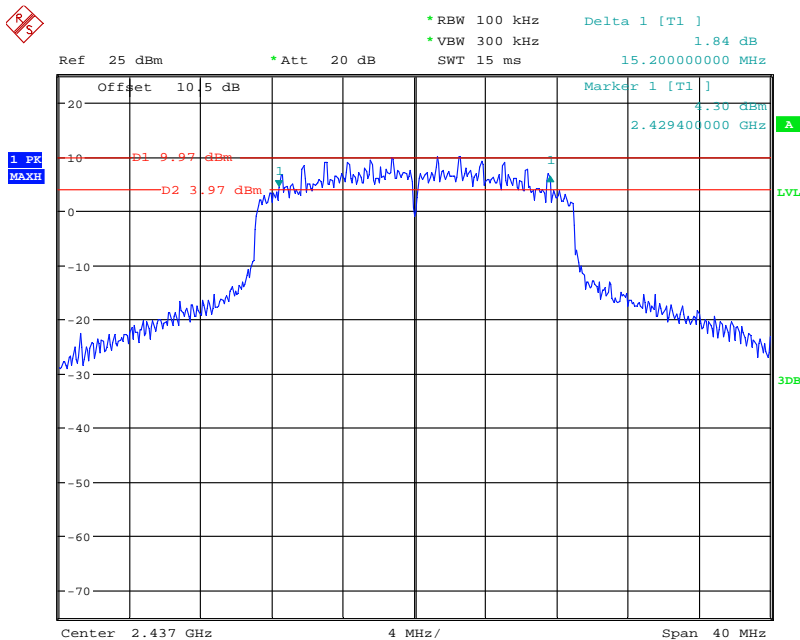

Date: 29.MAR.2021 12:14:08

802.11n ht20 High Channel

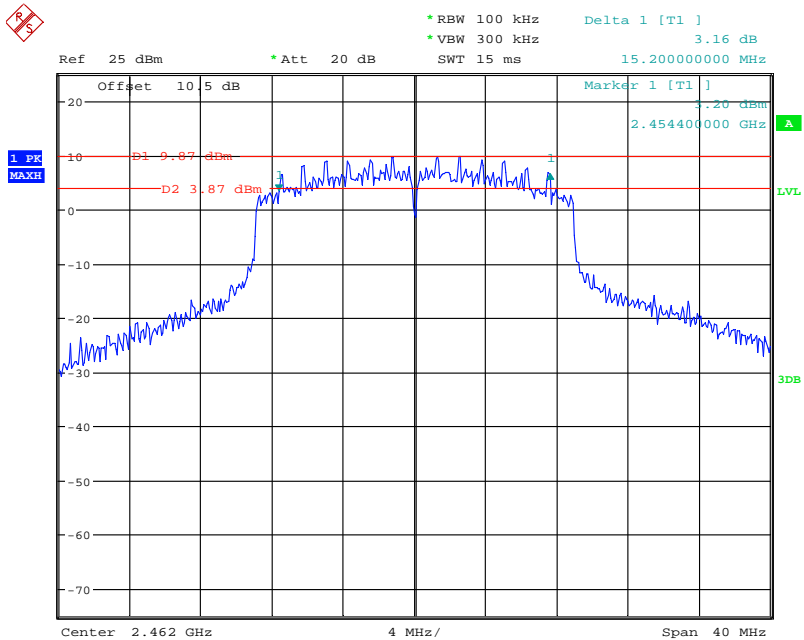

Date: 29.MAR.2021 12:58:13

99% Occupied Bandwidth:

802.11b Low Channel

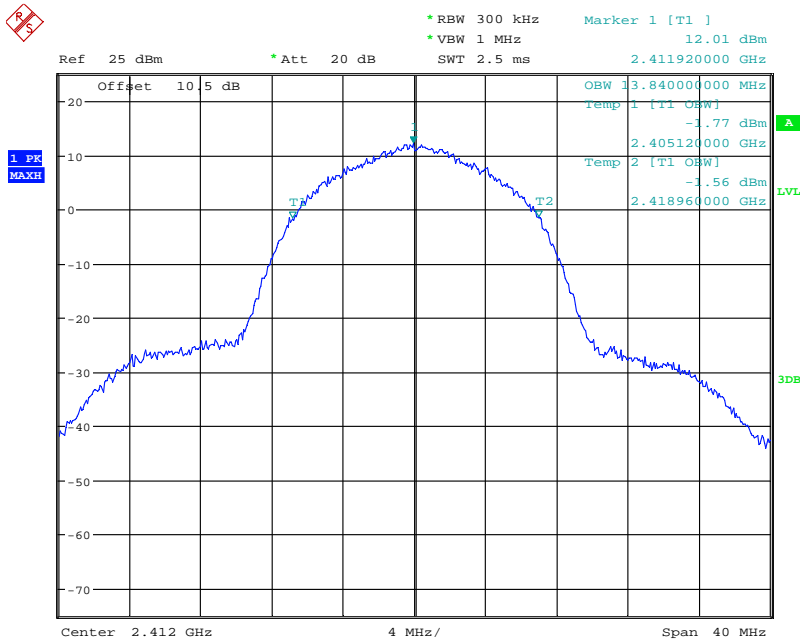

Date: 29.MAR.2021 12:01:24

802.11b Middle Channel

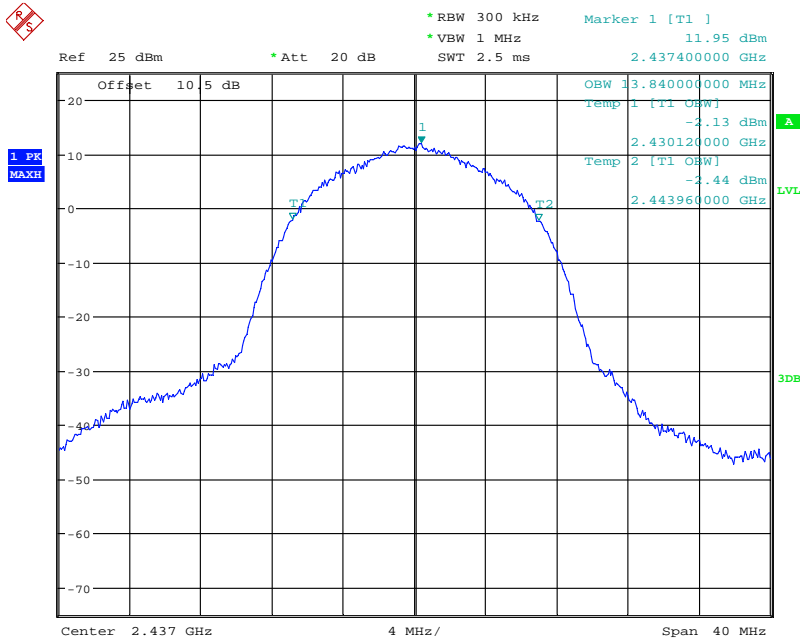

Date: 29.MAR.2021 12:03:16

802.11b High Channel

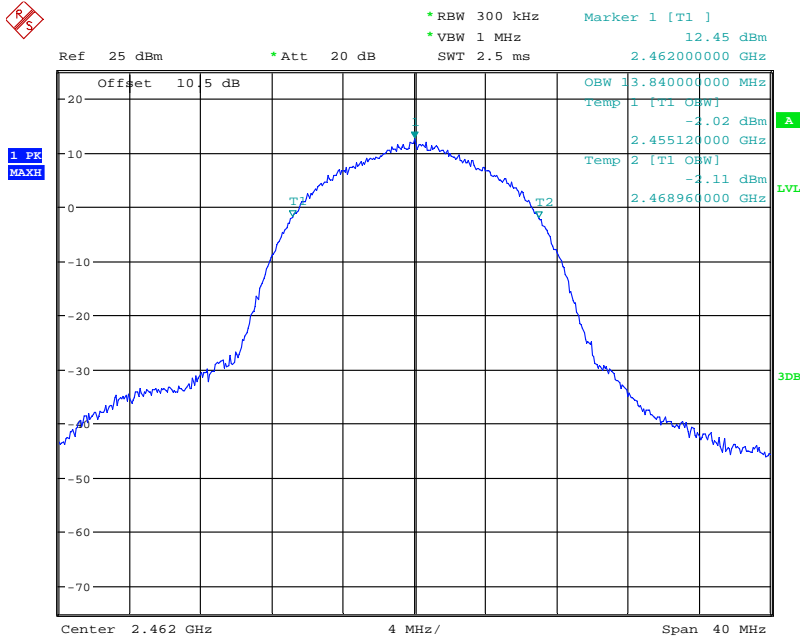

Date: 29.MAR.2021 12:05:09

802.11g Low Channel

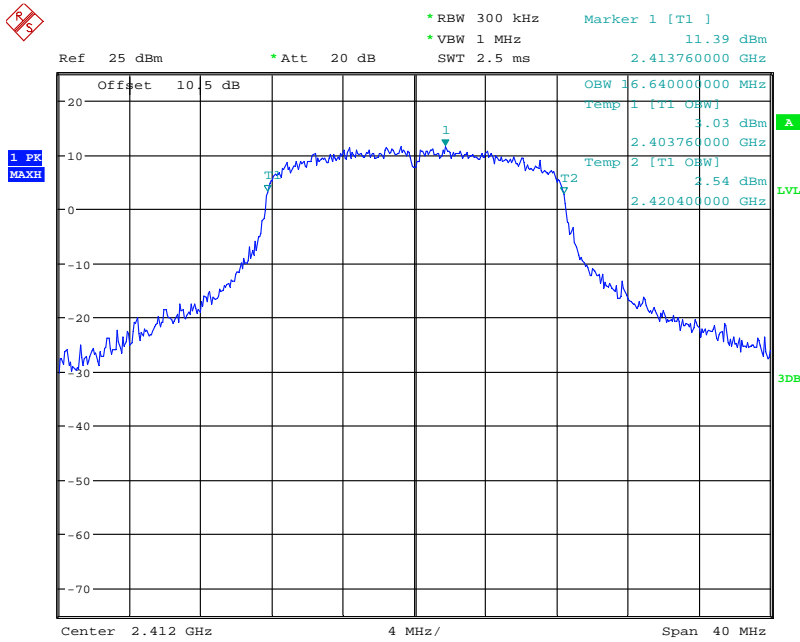

Date: 29.MAR.2021 12:06:58

802.11g Middle Channel

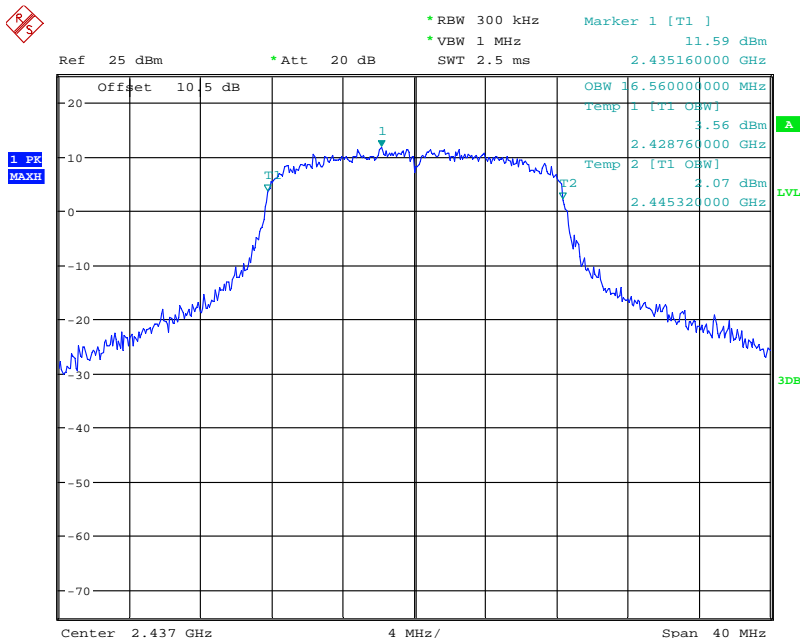

Date: 29.MAR.2021 12:09:13

802.11g High Channel

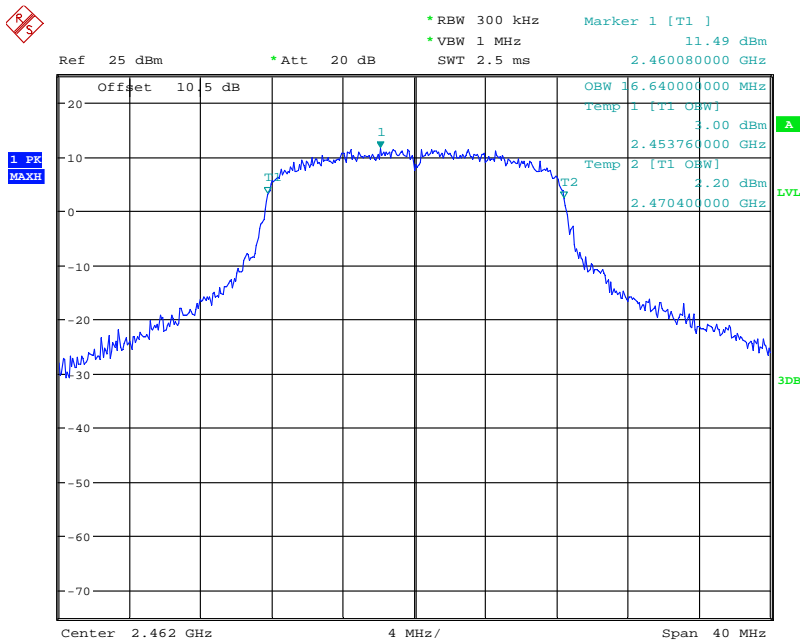

Date: 29.MAR.2021 12:10:39

802.11n ht20 Low Channel

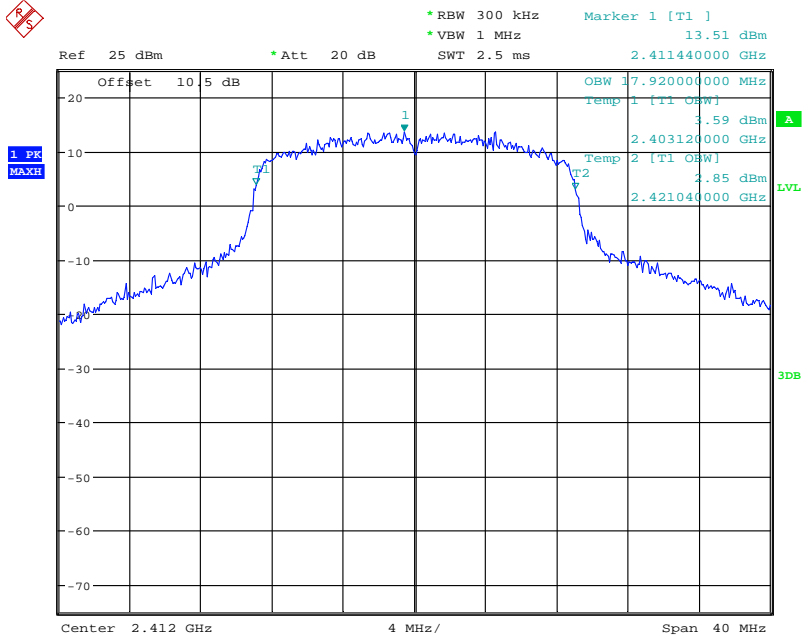

Date: 29.MAR.2021 12:12:36

802.11n ht20 Middle Channel

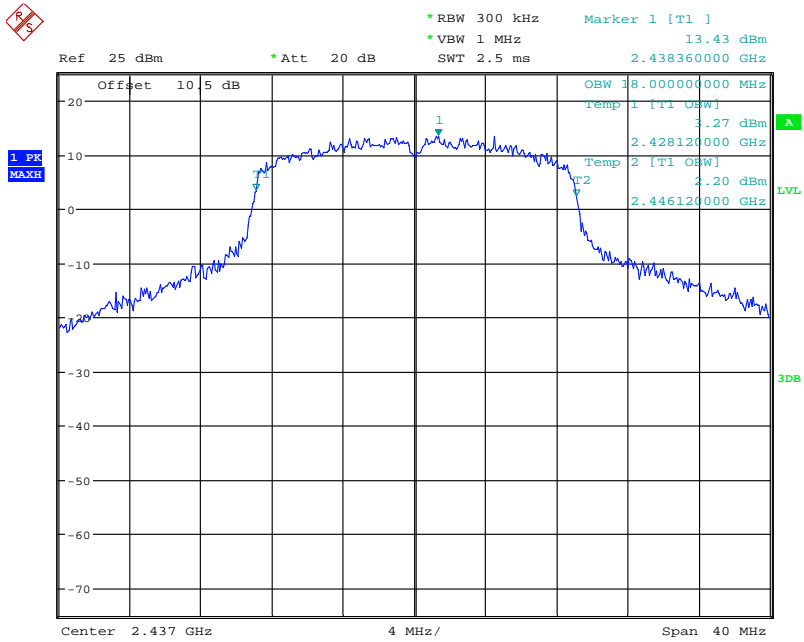

Date: 29.MAR.2021 12:14:25

802.11n ht20 High Channel

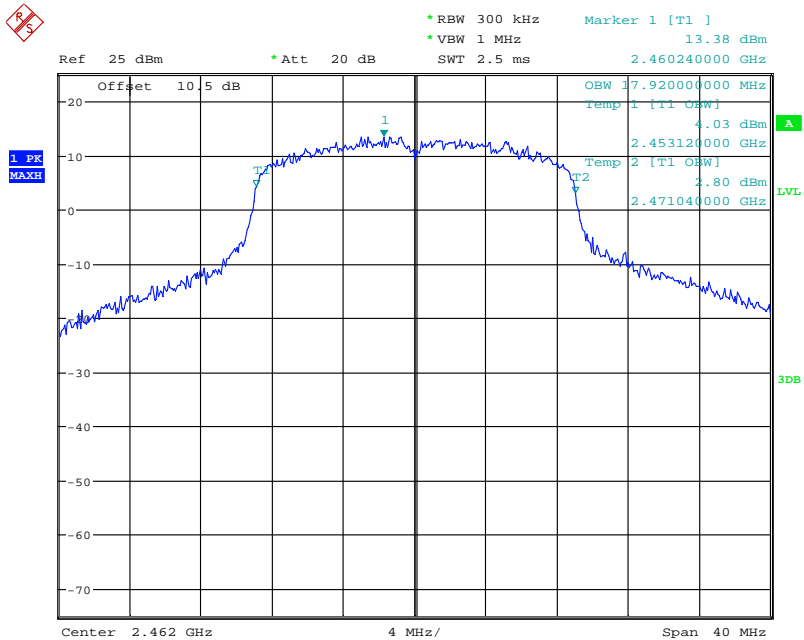

Date: 29.MAR.2021 12:15:59

FCC §15.247(b) (3), RSS-247 CLAUSE 5.4 d)- Maximum PEAK Conducted Output Power

Applicable Standard

According to FCC §15.247(b) (3), for systems using digital modulation in the 902-928 MHz, 2400-2483.5 MHz, and 5725-5850 MHz bands: 1 Watt. As an alternative to a peak power measurement, compliance with the one Watt limit can be based on a measurement of the maximum conducted output power. Maximum Conducted Output Power is defined as the total transmit power delivered to all antennas and antenna elements averaged across all symbols in the signaling alphabet when the transmitter is operating at its maximum power control level. Power must be summed across all antennas and antenna elements. The average must not include any time intervals during which the transmitter is off or is transmitting at a reduced power level. If multiple modes of operation are possible (e.g., alternative modulation methods), the maximum conducted output power is the highest total transmit power occurring in any mode.

According to RSS-247§5.4 d) For DTSs employing digital modulation techniques operating in the bands 902-928 MHz and 2400-2483.5 MHz, the maximum peak conducted output power shall not exceed 1W. Except as provided in Section 5.4(e), the e.i.r.p. shall not exceed 4 W.

As an alternative to a peak power measurement, compliance can be based on a measurement of the maximum conducted output power. The maximum conducted output power is the total transmit power delivered to all antennas and antenna elements, averaged across all symbols in the signalling alphabet when the transmitter is operating at its maximum power control level. Power must be summed across all antennas and antenna elements. The average must not include any time intervals during which the transmitter is off or transmitting at a reduced power level. If multiple modes of operation are implemented, the maximum conducted output power is the highest total transmit power occurring in any mode.

Test Procedure

1. Place the EUT on a bench and set it in transmitting mode.
2. Remove the antenna from the EUT and then connect a low loss RF cable from the antenna port to test equipment.
3. Add a correction factor to the display.
4. Set the power meter to test average output power, record the result as average power.

Test Equipment List

Manufacturer	Description	Model	Serial Number	Calibration Date	Calibration Due Date
E-Microwave	Blocking Control	EMDCB-00036	0E01201047	Each time	N/A
E-Microwave	Coaxial Attenuators	EMCA10-5RN-6	OE01203239	Each time	N/A
Unknown	Coaxial Cable	C-SJ00-0010	C0010/01	Each time	N/A
Agilent	USB Wideband Power Sensor	U2022XA	MY5417006	2020-09-12	2021-09-12

* **Statement of Traceability:** Bay Area Compliance Laboratories Corp. (Dongguan) attests that all calibrations have been performed, traceable to National Primary Standards and International System of Units (SI).

Test Data

Environmental Conditions

Temperature:	24.2 °C
Relative Humidity:	50 %
ATM Pressure:	100.1 kPa
Tester:	Wayne Wei
Test Date:	2021-03-29

Test Mode: Transmitting

Test Result: Compliance. Please refer to following tables and plots.

Mode	Frequency (MHz)	Peak Conducted Output Power (dBm)	Limit (dBm)
802.11b	2412	18.65	30
	2437	18.60	30
	2462	18.62	30
802.11g	2412	25.02	30
	2437	25.04	30
	2462	25.09	30
802.11n ht20	2412	25.16	30
	2437	25.25	30
	2462	25.28	30

The maximum antenna gain is -0.4dBi, the EIRP meet the RSS-247 requirement.

FCC §15.247(d), RSS-247 CLAUSE 5.5– 100 kHz BANDWIDTH OF FREQUENCY BAND EDGE

Applicable Standard

According to FCC§15.247(d):In any 100 kHz bandwidth outside the frequency band in which the spread spectrum or digitally modulated intentional radiator is operating, the radio frequency power that is produced by the intentional radiator shall be at least 20 dB below that in the 100 kHz bandwidth within the band that contains the highest level of the desired power, based on either an RF conducted or a radiated measurement, provided the transmitter demonstrates compliance with the peak conducted power limits. If the transmitter complies with the conducted power limits based on the use of RMS averaging over a time interval, as permitted under paragraph (b)(3) of this section, the attenuation required under this paragraph shall be 30 dB instead of 20 dB. Attenuation below the general limits specified in §15.209(a) is not required. In addition, radiated emissions which fall in the restricted bands, as defined in §15.205(a), must also comply with the radiated emission limits specified in §15.209(a) (see §15.205(c)).

According to RSS-247 Clause 5.5:

In any 100 kHz bandwidth outside the frequency band in which the spread spectrum or digitally modulated device is operating, the RF power that is produced shall be at least 20 dB below that in the 100 kHz bandwidth within the band that contains the highest level of the desired power, based on either an RF conducted or a radiated measurement, provided that the transmitter demonstrates compliance with the peak conducted power limits. If the transmitter complies with the conducted power limits based on the use of root-mean-square averaging over a time interval, as permitted under section 5.4(d), the attenuation required shall be 30 dB instead of 20 dB. Attenuation below the general field strength limits specified in RSS-Gen is not required.

Test Procedure

1. Check the calibration of the measuring instrument using either an internal calibrator or a known signal from an external generator.
2. Position the EUT without connection to measurement instrument. Turn on the EUT and connect its antenna terminal to measurement instrument via a low loss cable. Then set it to any one measured frequency within its operating range, and make sure the instrument is operated in its linear range.
3. Set RBW to 100 kHz and VBW of spectrum analyzer to 300 kHz with a convenient frequency span including 100 kHz bandwidth from band edge.
4. Measure the highest amplitude appearing on spectral display and set it as a reference level. Plot the graph with marking the highest point and edge frequency.
5. Repeat above procedures until all measured frequencies were complete.

Test Equipment List

Manufacturer	Description	Model	Serial Number	Calibration Date	Calibration Due Date
R&S	Spectrum Analyzer	FSU 26	200256	2020-07-07	2021-07-07
E-Microwave	Coaxial Attenuators	EMCA10-5RN-6	OE01203239	2020-09-06	2021-09-06
Unknown	Coaxial Cable	C-SJ00-0010	C0010/01	Each time	N/A

* **Statement of Traceability:** Bay Area Compliance Laboratories Corp. (Dongguan) attests that all calibrations have been performed, traceable to National Primary Standards and International System of Units (SI).

Test Data

Environmental Conditions

Temperature:	24.2 °C
Relative Humidity:	50 %
ATM Pressure:	100.1 kPa
Tester:	Wayne Wei
Test Date:	2021-03-29

Test Mode: Transmitting

Test Result: Compliance. Please refer to following tables and plots.

802.11b: Band Edge, Left Side

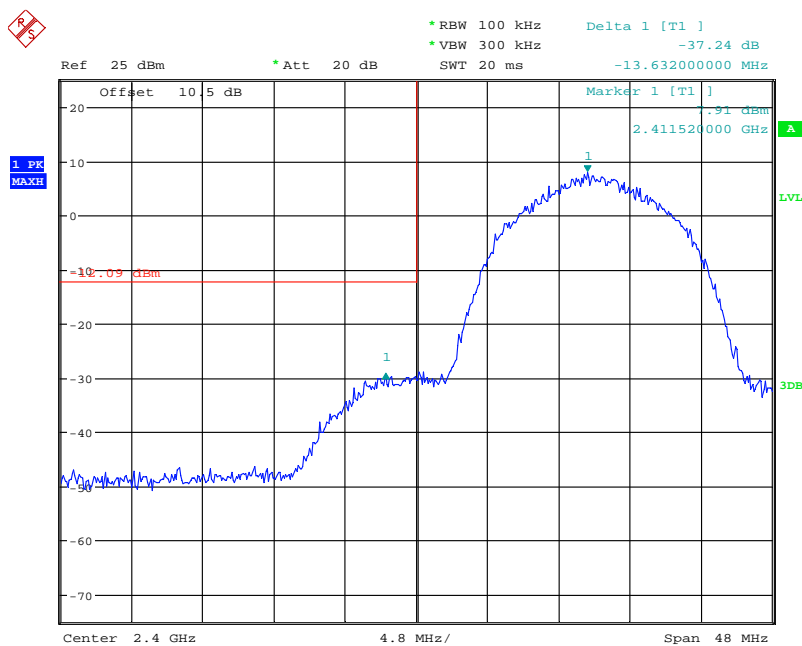

Date: 29.MAR.2021 12:01:58

802.11b: Band Edge, Right Side

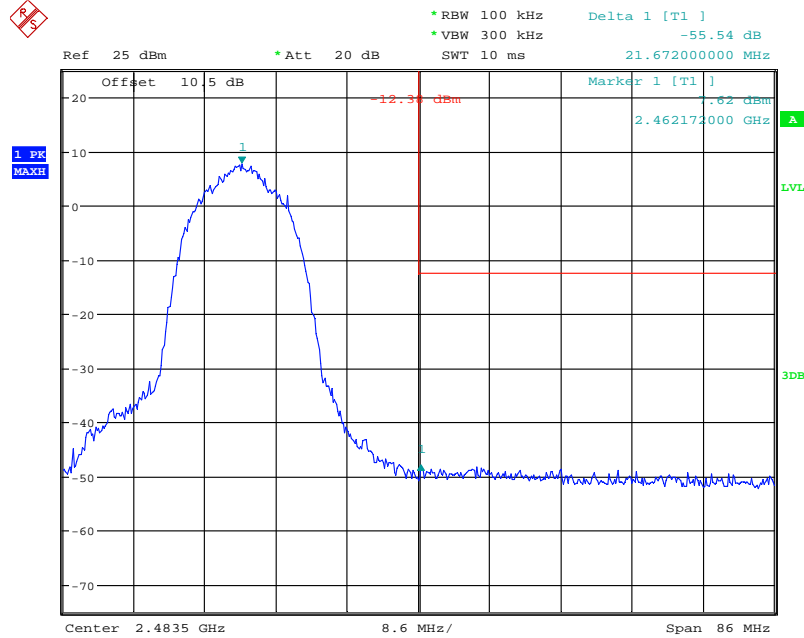

Date: 29.MAR.2021 12:05:56

802.11g: Band Edge, Left Side

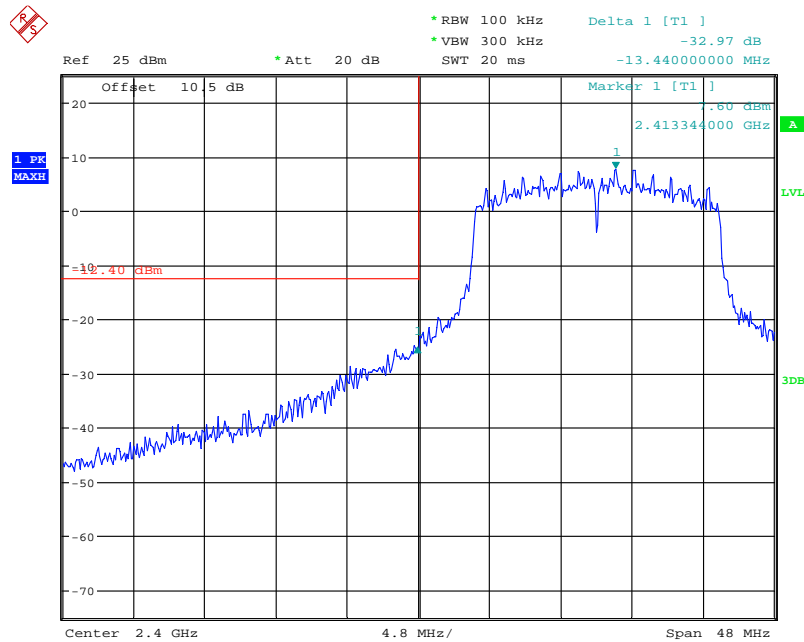

Date: 29.MAR.2021 12:07:44

802.11g: Band Edge, Right Side

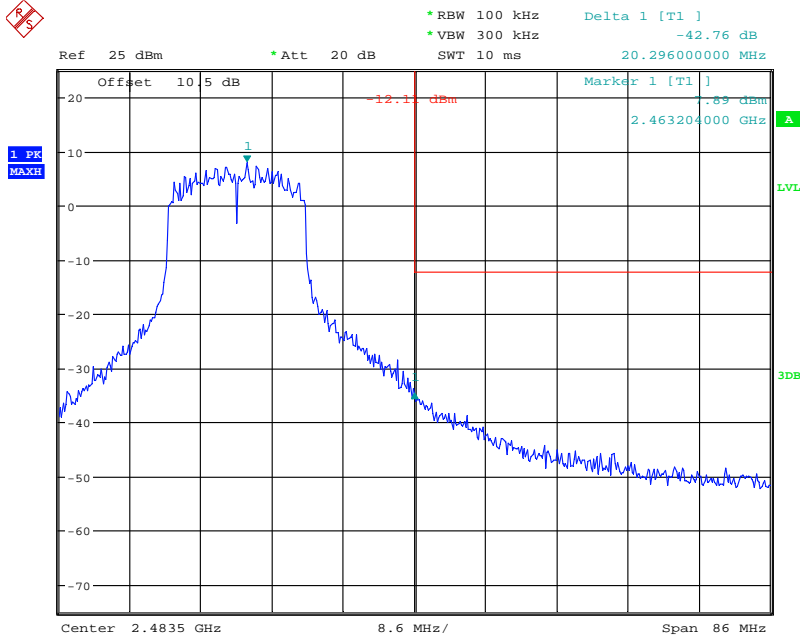

Date: 29.MAR.2021 12:11:25

802.11n ht20: Band Edge, Left Side

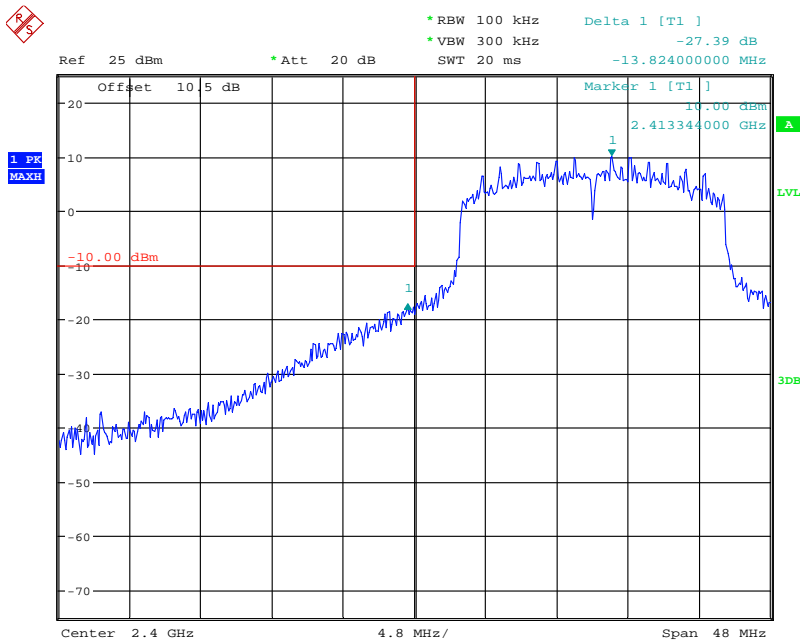

Date: 29.MAR.2021 12:13:26

802.11n ht20: Band Edge, Right Side

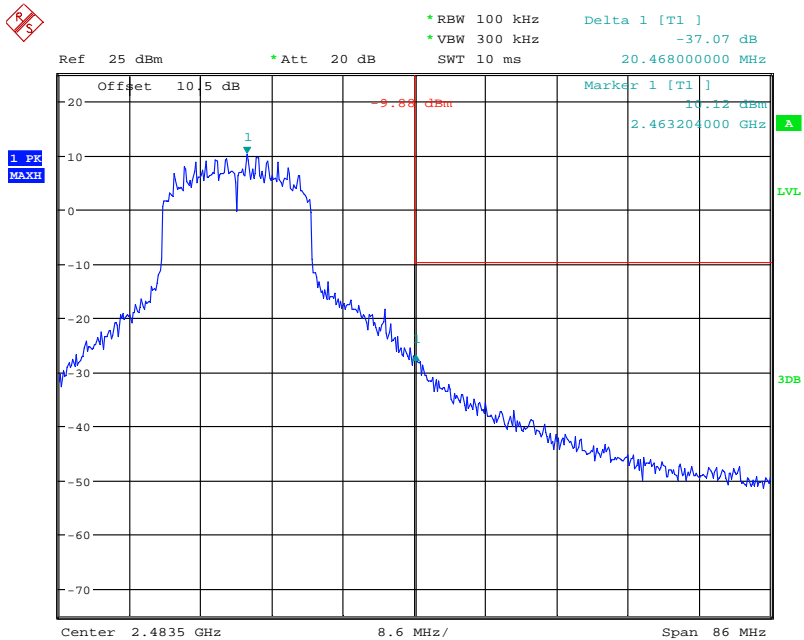

Date: 29.MAR.2021 12:16:44

FCC §15.247(e), RSS-247 CLAUSE 5.2 b)- POWER SPECTRAL DENSITY

Applicable Standard

For digitally modulated systems, the power spectral density conducted from the intentional radiator to the antenna shall not be greater than 8 dBm in any 3 kHz band during any time interval of continuous transmission. This power spectral density shall be determined in accordance with the provisions of paragraph (b) of this section. The same method of determining the conducted output power shall be used to determine the power spectral density.

According to RSS-247 §5.2 b):

- b) The transmitter power spectral density conducted from the transmitter to the antenna shall not be greater than 8 dBm in any 3 kHz band during any time interval of continuous transmission. This power spectral density shall be determined in accordance with the provisions of section 5.4(d), (i.e. the power spectral density shall be determined using the same method as is used to determine the conducted output power).

Test Procedure

1. Check the calibration of the measuring instrument using either an internal calibrator or a known signal from an external generator.
2. Position the EUT was set without connection to measurement instrument. Turn on the EUT and connect its antenna terminal to measurement instrument via a low loss cable. Then set it to any one measured frequency within its operating range, and make sure the instrument is operated in its linear range.
3. Set the RBW = 3 kHz, VBW = 10 kHz, Set the span to 1.5 times the DTS bandwidth.
4. Use the peak marker function to determine the maximum amplitude level.

Test Equipment List

Manufacturer	Description	Model	Serial Number	Calibration Date	Calibration Due Date
R&S	Spectrum Analyzer	FSU 26	200256	2020-07-07	2021-07-07
E-Microwave	Coaxial Attenuators	EMCA10-5RN-6	OE01203239	2020-09-06	2021-09-06
Unknown	Coaxial Cable	C-SJ00-0010	C0010/01	Each time	N/A

* Statement of Traceability: Bay Area Compliance Laboratories Corp. (Dongguan) attests that all calibrations have been performed, traceable to National Primary Standards and International System of Units (SI).

Test Data

Environmental Conditions

Temperature:	24.2 °C
Relative Humidity:	50 %
ATM Pressure:	100.1 kPa
Tester:	Wayne Wei
Test Date:	2021-03-29

Test Mode: Transmitting

Test Result: Compliance. Please refer to following tables and plots.

Test mode	Frequency (MHz)	Power Spectral Density	Limit (dBm/3kHz)
802.11 b	2412	-7.42	≤8
	2437	-6.89	≤8
	2462	-6.83	≤8
802.11 g	2412	-7.48	≤8
	2437	-7.35	≤8
	2462	-6.67	≤8
802.11n ht20	2412	-4.67	≤8
	2437	-5.73	≤8
	2462	-5.88	≤8

Power Spectral Density, 802.11b Low Channel

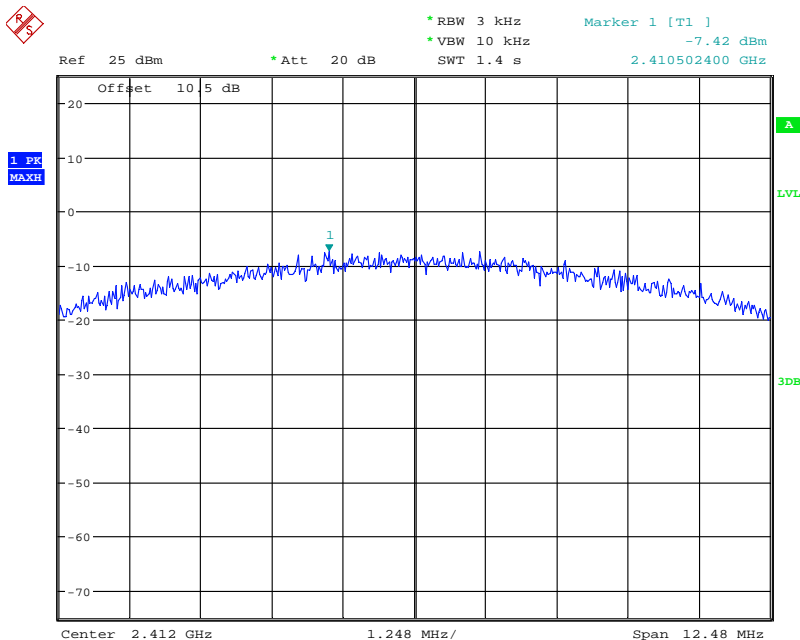

Date: 29.MAR.2021 12:01:45

Power Spectral Density, 802.11b Middle Channel

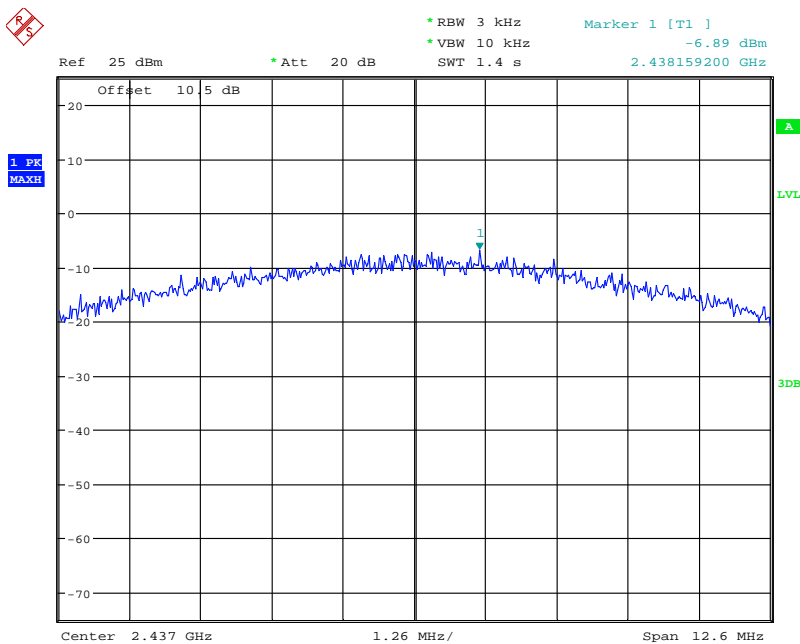

Date: 29.MAR.2021 12:03:37

Power Spectral Density, 802.11b High Channel

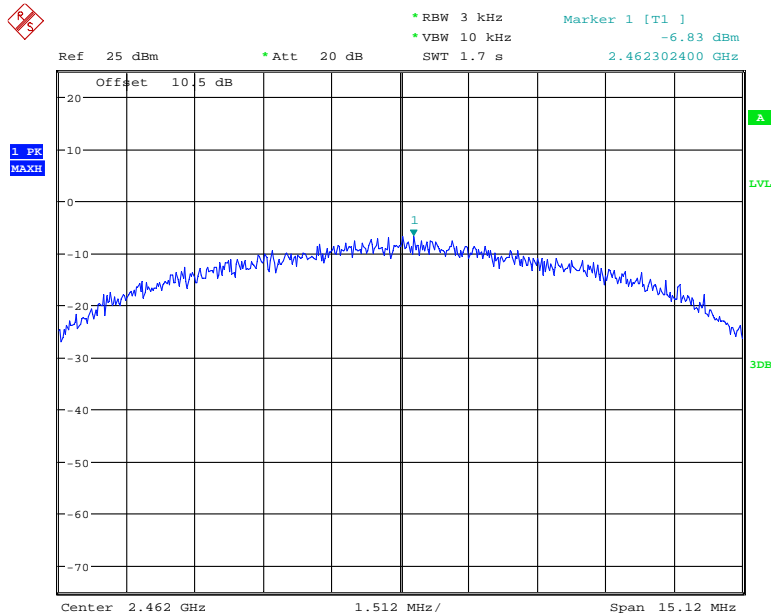

Date: 29.MAR.2021 12:05:39

Power Spectral Density, 802.11g Low Channel

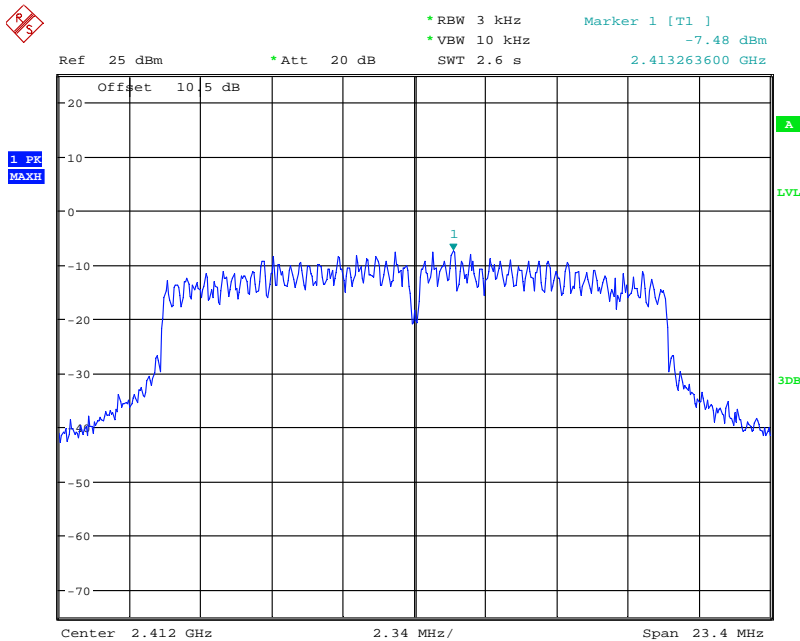

Date: 29.MAR.2021 12:07:31

Power Spectral Density, 802.11g Middle Channel

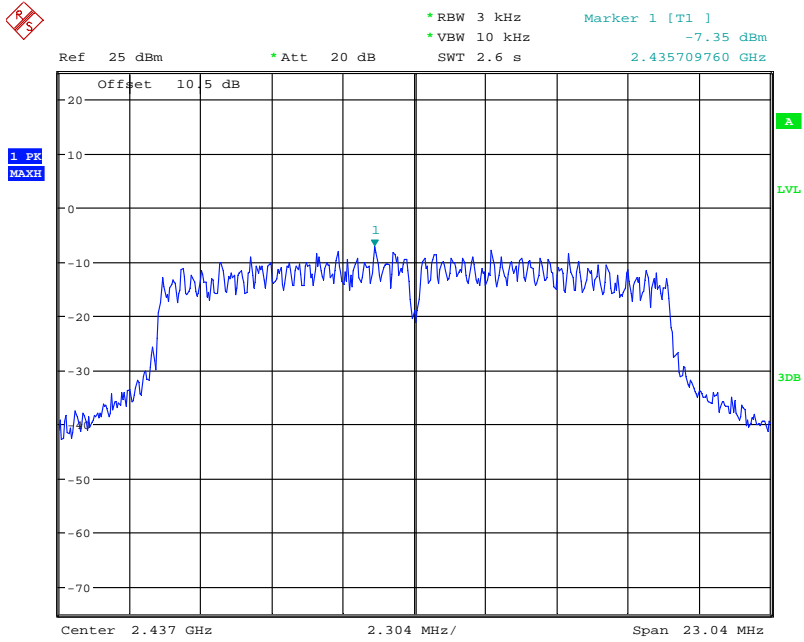

Date: 29.MAR.2021 12:09:46

Power Spectral Density, 802.11g High Channel

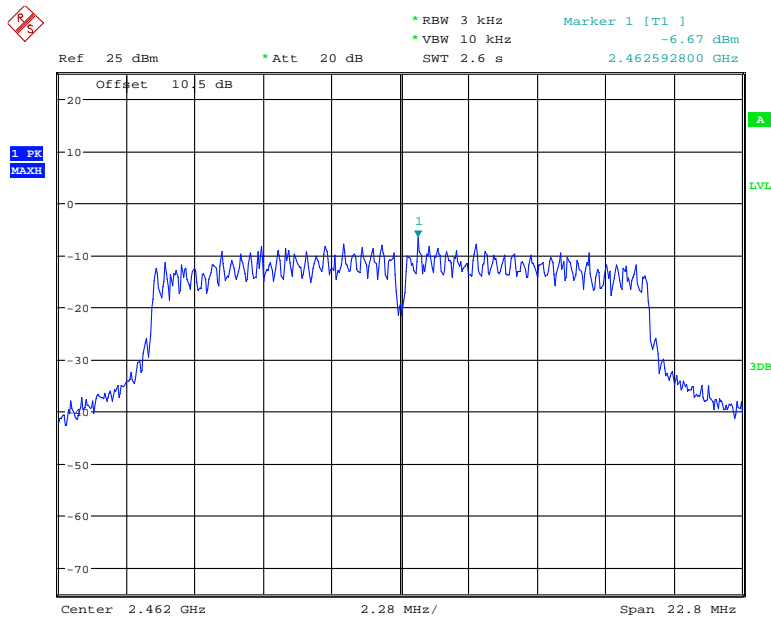

Date: 29.MAR.2021 12:11:12

Power Spectral Density, 802.11n ht20 Low Channel

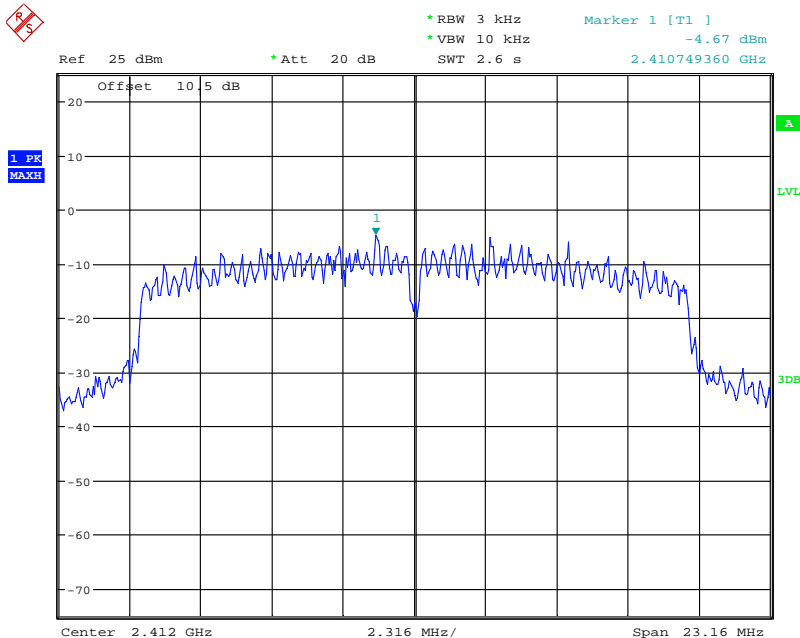

Date: 29.MAR.2021 12:13:09

Power Spectral Density, 802.11n ht20 Middle Channel

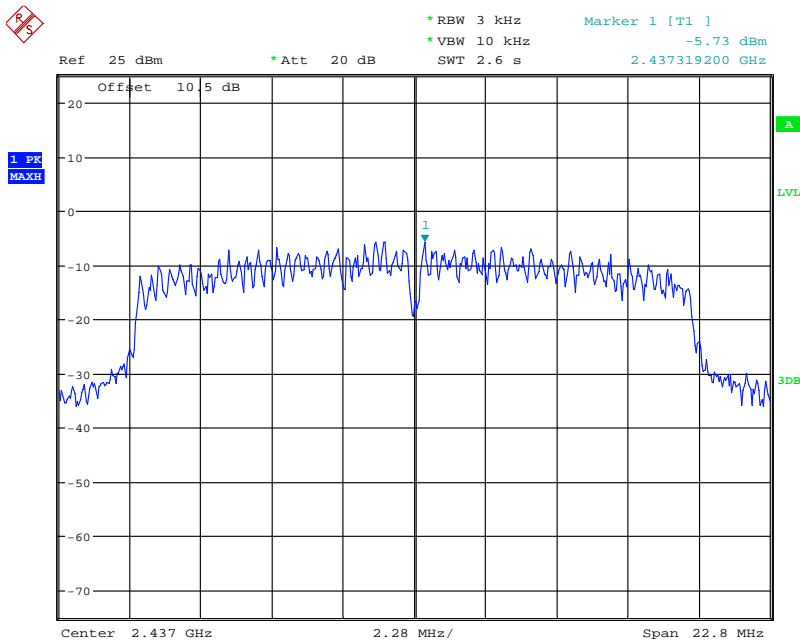

Date: 29.MAR.2021 12:14:58

Power Spectral Density, 802.11n ht20 High Channel

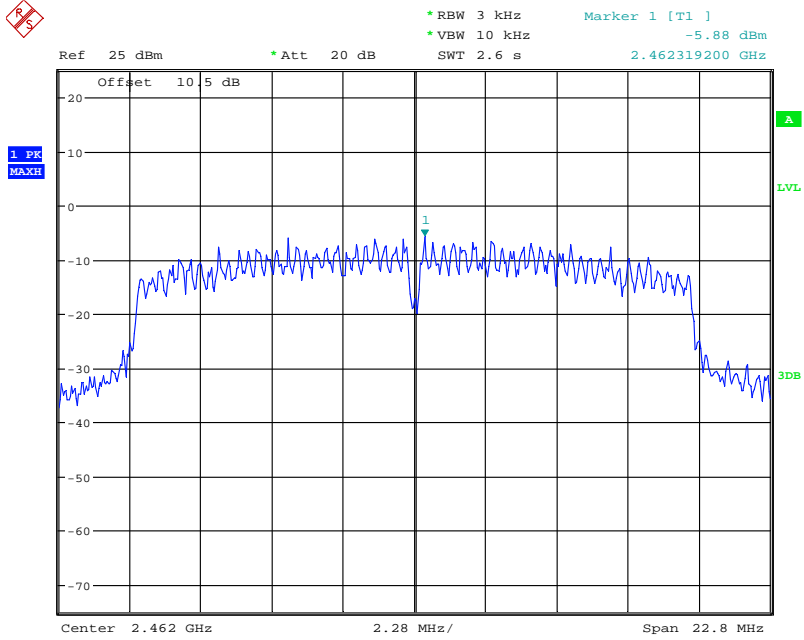

Date: 29.MAR.2021 12:16:31

***** END OF REPORT *****