

S

T

S

L

A

B



RADIO TEST REPORT

Report No.: STS2111168W09

Issued for

Chengdu Just Do It Information and Technology Co., Ltd.

Rm 604&605, Unit 1, Building 2, No. 1, Section 1, Huafu Avenue, Huayang Street, Tianfu New District, Chengdu, China.

Product Name:	Bobcat IoT hotspot
Brand Name:	BOBCAT
Model Name:	Bobcat Miner 300
Series Model:	N/A
FCC ID:	2AZCK-MINER3001
IC:	27477-MINER3001
Test Standard:	FCC Part 15.247 RSS-247 Issue 2, February 2017 RSS-Gen Issue 5, Amendment 2, February 2021

Any reproduction of this document must be done in full. No single part of this document may be reproduced without permission from STS, all test data presented in this report is only applicable to presented test sample.

Shenzhen STS Test Services Co., Ltd.
A 1/F, Building B, Zhuoke Science Park, No.190 Chongqing Road, HepingShequ,
Fuyong Sub-District, Bao'an District, Shenzhen, Guang Dong, China
TEL: +86-755 3688 6288 FAX: +86-755 3688 6277 E-mail: sts@stsapp.com





TEST RESULT CERTIFICATION

Applicant's Name.....: Chengdu Just Do It Information and Technology Co., Ltd.
 Address: Rm 604&605, Unit 1, Building 2, No. 1, Section 1, Huafu Avenue, Huayang Street, Tianfu New District, Chengdu, China.
Manufacturer's Name: Chengdu Just Do It Information and Technology Co., Ltd.
 Address: Rm 604&605, Unit 1, Building 2, No. 1, Section 1, Huafu Avenue, Huayang Street, Tianfu New District, Chengdu, China.

Product Description

Product Name.....: Bobcat IoT hotspot
 Brand Name: BOBCAT
 Model Name: Bobcat Miner 300
 Series Model.....: N/A

Test Standards.....: FCC Part15.247
 RSS-247 Issue 2, February 2017
 RSS-Gen Issue 5, Amendment 2, February 2021

Test Procedure: ANSI C63.10-2013

This device described above has been tested by STS, the test results show that the equipment under test (EUT) is in compliance with the FCC/IC requirements. And it is applicable only to the tested sample identified in the report.

This report shall not be reproduced except in full, without the written approval of STS, this document may be altered or revised by STS, personal only, and shall be noted in the revision of the document.

Date of Test

Date of receipt of test item: 26 Nov. 2021
 Date (s) of performance of tests: 26 Nov. 2021 ~ 01 Dec. 2021
 Date of Issue.....: 01 Dec. 2021

Test Result.....: **Pass**

Testing Engineer :

Chris Chen

(Chris Chen)

Technical Manager :

Sean She

(Sean she)

Authorized Signatory :

Vita Li

(Vita Li)





Table of Contents

1. SUMMARY OF TEST RESULTS	6
1.1 TEST FACTORY	7
1.2 MEASUREMENT UNCERTAINTY	7
2. GENERAL INFORMATION	8
2.1 GENERAL DESCRIPTION OF THE EUT	8
2.2 DESCRIPTION OF THE TEST MODES	10
2.3 TEST SOFTWARE AND POWER LEVEL	10
2.4 BLOCK DIAGRAM SHOWING THE CONFIGURATION OF SYSTEM TESTED	11
2.5 DESCRIPTION OF NECESSARY ACCESSORIES AND SUPPORT UNITS	12
2.6 EQUIPMENTS LIST	13
3. EMC EMISSION TEST	15
3.1 CONDUCTED EMISSION MEASUREMENT	15
3.2 TEST PROCEDURE	16
3.3 TEST SETUP	16
3.4 EUT OPERATING CONDITIONS	16
3.5 TEST RESULTS	17
4. RADIATED EMISSION MEASUREMENT	19
4.1 RADIATED EMISSION LIMITS	19
4.2 TEST PROCEDURE	22
4.3 TEST SETUP	23
4.4 EUT OPERATING CONDITIONS	23
4.5 FIELD STRENGTH CALCULATION	24
4.6 TEST RESULTS	25
5. CONDUCTED SPURIOUS & BAND EDGE EMISSION	32
5.1 LIMIT	32
5.2 TEST PROCEDURE	32
5.3 TEST SETUP	32
5.4 EUT OPERATION CONDITIONS	32
5.5 TEST RESULTS	33
6. POWER SPECTRAL DENSITY TEST	37
6.1 LIMIT	37
6.2 TEST PROCEDURE	37



Table of Contents

6.3 TEST SETUP	37
6.4 EUT OPERATION CONDITIONS	37
6.5 TEST RESULTS	38
7. BANDWIDTH TEST	40
7.1 LIMIT	40
7.2 TEST PROCEDURE	40
7.3 TEST SETUP	40
7.4 EUT OPERATION CONDITIONS	40
7.5 TEST RESULTS	41
8. PEAK OUTPUT POWER TEST	45
8.1 LIMIT	45
8.2 TEST PROCEDURE	45
8.3 TEST SETUP	46
8.4 EUT OPERATION CONDITIONS	46
8.5 TEST RESULTS	47
9. ANTENNA REQUIREMENT	49
9.1 STANDARD REQUIREMENT	49
9.2 EUT ANTENNA	49
10. FREQUENCY STABILITY	50
10.1 LIMITS OF FREQUENCY STABILITY MEASUREMENT	50
10.2 TEST PROCEDURE	50
10.3 TEST RESULT	50
11. EUT TEST PHOTO	51

**Revision History**

Rev.	Issue Date	Report NO.	Effect Page	Contents
00	01 Dec. 2021	STS2111168W09	ALL	Initial Issue





1. SUMMARY OF TEST RESULTS

Test procedures according to the technical standards:
KDB 558074 D01 15.247 Meas Guidance v05r02.

FCC Part 15.247, Subpart C RSS-247 Issue 2			
Standard Section	Test Item	Judgment	Remark
15.207 RSS-Gen (8.8&7.2)	Conducted Emission	PASS	--
15.247 (a)(2) RSS-Gen 6.7 RSS-247 5.2 (a)	6dB&99% Bandwidth	PASS	--
15.247 (b)(3) RSS-247 5.4 (d)	Output Power	PASS	--
15.209 RSS-Gen 8.9/8.10	Radiated Spurious Emission	PASS	--
15.247 (d) RSS-247 5.5 RSS-Gen 8.9/8.10	Conducted Spurious & Band Edge Emission	PASS	--
15.247 (e) RSS-247 5.2 (b)	Power Spectral Density	PASS	--
15.205 RSS-Gen 8.9/8.10	Restricted bands of operation	N/A	--
15.203 RSS-Gen 6.8	Antenna Requirement	PASS	--
RSS-Gen 6.11/8.11	Frequency Stability	PASS	--

NOTE:

- (1) 'N/A' denotes test is not applicable in this Test Report.
- (2) All tests are according to ANSI C63.10-2013.



1.1 TEST FACTORY

SHENZHEN STS TEST SERVICES CO., LTD

Add. : A 1/F, Building B, Zhuoke Science Park, No.190 Chongqing Road, HepingShequ, Fuyong Sub-District, Bao'an District, Shenzhen, Guang Dong, China

FCC test Firm Registration Number: 625569

IC test Firm Registration Number: 12108A

A2LA Certificate No.: 4338.01

1.2 MEASUREMENT UNCERTAINTY

The reported uncertainty of measurement $y \pm U$, where expanded uncertainty U is based on a standard uncertainty multiplied by a coverage factor of $k=2$, providing a level of confidence of approximately **95** %.

No.	Item	Uncertainty
1	RF output power, conducted	$\pm 0.68\text{dB}$
2	Unwanted Emissions, conducted	$\pm 2.988\text{dB}$
3	All emissions, radiated 9K-30MHz	$\pm 2.84\text{dB}$
4	All emissions, radiated 30M-1GHz	$\pm 4.39\text{dB}$
5	All emissions, radiated 1G-6GHz	$\pm 5.10\text{dB}$
6	All emissions, radiated >6G	$\pm 5.48\text{dB}$
7	Conducted Emission (9KHz-150KHz)	$\pm 2.79\text{dB}$
8	Conducted Emission (150KHz-30MHz)	$\pm 2.80\text{dB}$



2. GENERAL INFORMATION

2.1 GENERAL DESCRIPTION OF THE EUT

Product Name/PMN	Bobcat IoT hotspot	
Trade Name	BOBCAT	
Model Name	Bobcat Miner 300	
HVIN	MINER3001	
Series Model	N/A	
Model Difference	N/A	
Product Description	The EUT is a Bobcat IoT hotspot	
	Operation Frequency:	903 – 927MHz
	Modulation Type:	FSK
	Number Of Channel:	CH 41
	Antenna Designation:	Please refer to the Note 3.
	Antenna Gain (dBi)	4dBi
Channel List	Please refer to the Note 2.	
Adapter	Model: A938-120100W-US1 Input: 100-240V~ 50/60Hz, 0.35A Output: DC 12V 1A	
	Model: PS120W1000U Input: 100-240V~ 50/60Hz, 0.5A Output: DC 12V 1A	
Battery	Rated Voltage: 3V Capacity: 40mAh	
Hardware version number	V2.0	
Software version number/FVIN	2021.11.09.01.00	
Serial Numbers	G290E1ZJ214400021	
Connecting I/O Port(s)	Please refer to the Note 1.	

Note:

1. For a more detailed features description, please refer to the manufacturer's specifications or the User Manual.



2.

Channel List					
Channel	Frequency (MHz)	Channel	Frequency (MHz)	Channel	Frequency (MHz)
1	903.0	15	911.4	29	919.8
2	903.6	16	912.0	30	920.4
3	904.2	17	912.6	31	921.0
4	904.8	18	913.2	32	921.6
5	905.4	19	913.8	33	922.2
6	906.0	20	914.4	34	922.8
7	906.6	21	915.0	35	923.4
8	907.2	22	915.6	36	924.0
9	907.8	23	916.2	37	924.6
10	908.4	24	916.8	38	925.2
11	909.0	25	917.4	39	925.8
12	909.6	26	918.0	40	926.4
13	910.2	27	918.6	41	927.0
14	910.8	28	919.2	--	--

3.

Table for Filed Antenna

Ant.	Brand	Model Name	Antenna Type	Connector	Gain (dBi)	NOTE
1	BOBCAT	Bobcat Miner 300	External	N/A	4dBi	FSK ANT

Note: The antenna information refer the manufacturer provide report, applicable only to the tested sample identified in the report.



2.2 DESCRIPTION OF THE TEST MODES

For conducted test items and radiated spurious emissions

Each of these EUT operation mode(s) or test configuration mode(s) mentioned below was evaluated respectively.

Worst Mode	Description	Data/Modulation
Mode 1	TX CH01(903.0MHz)	FSK
Mode 2	TX CH21(915.0MHz)	FSK
Mode 3	TX CH41(932.0MHz)	FSK

Note:

- (1) The measurements are performed at all Bit Rate of Transmitter, the worst data was reported.
- (2) We tested for all available U.S. voltage and frequencies (For 120V, 50/60Hz and 240V, 50/60Hz) for which the device is capable of operation, and the worst case of 120V/ 60Hz is shown in the report.
- (3) The battery is fully-charged during the radiated and RF conducted test.

For AC Conducted Emission

Test Case	
AC Conducted Emission	Mode 4 : Keeping TX

2.3 TEST SOFTWARE AND POWER LEVEL

During testing channel & power controlling software provided by the customer was used to control the operating channel as well as the output power level.

RF Function	Type	Mode Or Modulation type	Ant Gain(dBi)	Power Class	Software For Testing
FSK 500KHz	903M~927MHz	FSK	4	0	CMD

2.4 BLOCK DIAGRAM SHOWING THE CONFIGURATION OF SYSTEM TESTED

Radiated Spurious Emission Test

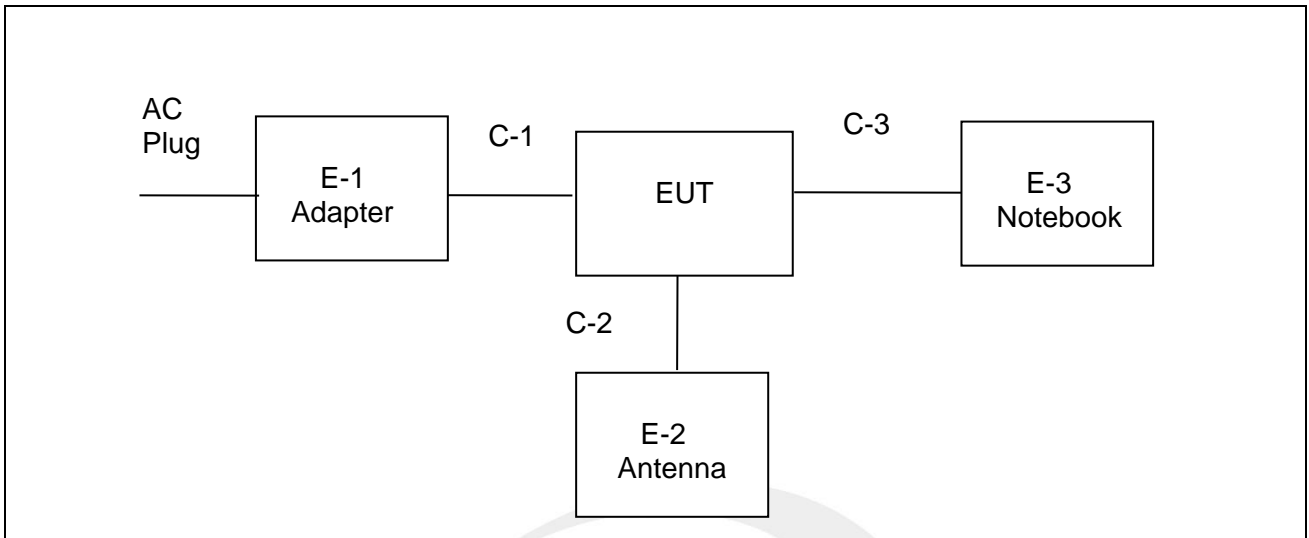

Conducted Emission Test

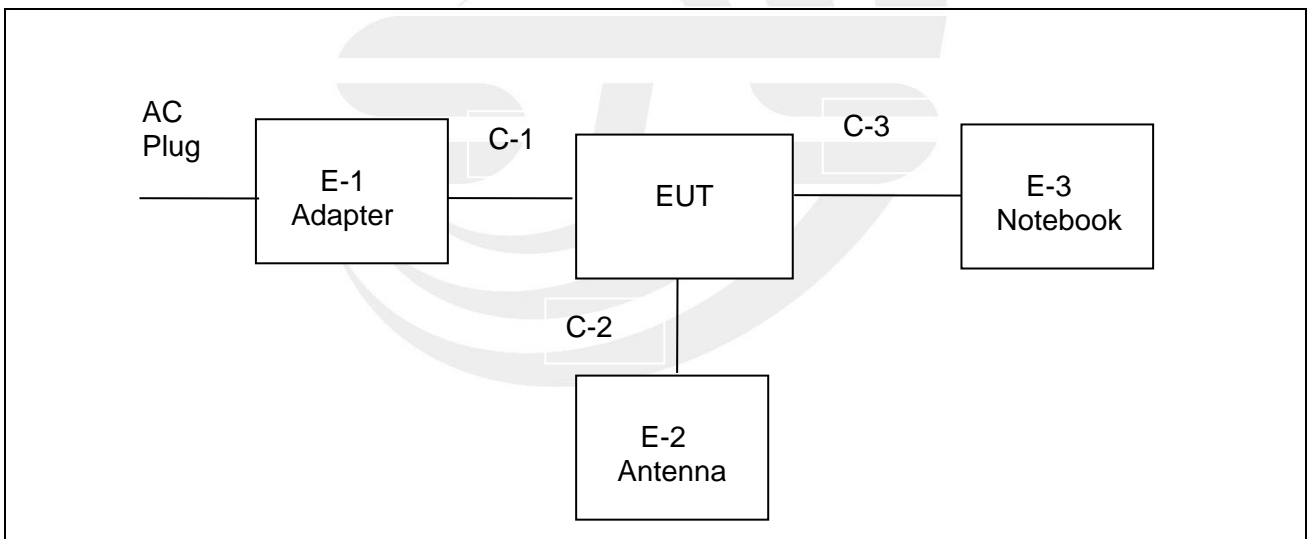



2.5 DESCRIPTION OF NECESSARY ACCESSORIES AND SUPPORT UNITS

The EUT has been tested as an independent unit together with other necessary accessories or support units. The following support units or accessories were used to form a representative test configuration during the tests.

Necessary accessories

Item	Equipment	Mfr/Brand	Model/Type No.	Length	Note
E-1	Adapter	N/A	A938-120100W-US1	N/A	N/A
E-2	Antenna	N/A	N/A	N/A	N/A
C-1	DC Cable	N/A	N/A	150cm	NO
C-2	Signal Cable	N/A	N/A	100cm	NO

Support units

Item	Equipment	Mfr/Brand	Model/Type No.	Length	Note
E-3	Notebook	HP	500-320cx	N/A	N/A
C-3	USB Cable	N/A	N/A	80cm	NO

Note:

- (1) For detachable type I/O cable should be specified the length in cm in 『Length』 column.
- (2) “YES” is means “with core”; “NO” is means “without core”.



2.6 EQUIPMENTS LIST

Radiation Test equipment

Kind of Equipment	Manufacturer	Type No.	Serial No.	Last calibration	Calibrated until
Test Receiver	R&S	ESCI	101427	2021.09.30	2022.09.29
Signal Analyzer	R&S	FSV 40-N	101823	2021.09.30	2022.09.29
Active loop Antenna	ZHINAN	ZN30900C	16035	2021.04.11	2023.04.10
Bilog Antenna	TESEQ	CBL6111D	34678	2020.10.12	2022.10.11
Horn Antenna	SCHWARZBECK	BBHA 9120D	02014	2021.10.11	2023.10.10
SHF-EHF Horn Antenna (18G-40GHz)	A-INFO	LB-180400-KF	J211020657	2020.10.12	2022.10.11
Pre-Amplifier (0.1M-3GHz)	EM	EM330	060665	2021.10.08	2022.10.07
Pre-Amplifier (1G-18GHz)	SKET	LNPA-01018G-45	SK2018080901	2021.09.30	2022.09.29
Pre-Amplifier (18G-40GHz)	SKET	LNPA-1840-50	SK2018101801	2021.09.28	2022.09.27
Temperature & Humidity	HH660	Mieo	N/A	2021.10.09	2022.10.08
Turn table	EM	SC100_1	60531	N/A	N/A
Antenna mast	EM	SC100	N/A	N/A	N/A
Test SW	FARAD	EZ-EMC(Ver.STSLAB-03A1 RE)			

Conduction Test equipment

Kind of Equipment	Manufacturer	Type No.	Serial No.	Last calibration	Calibrated until
Test Receiver	R&S	ESCI	101427	2021.09.30	2022.09.29
LISN	R&S	ENV216	101242	2021.09.30	2022.09.29
LISN	EMCO	3810/2NM	23625	2021.09.30	2022.09.29
Temperature & Humidity	HH660	Mieo	N/A	2021.10.09	2022.10.08
Test SW	FARAD	EZ-EMC(Ver.STSLAB-03A1 CE)			



RF Connected Test

Kind of Equipment	Manufacturer	Type No.	Serial No.	Last calibration	Calibrated until
Power Sensor	Keysight	U2021XA	MY55520005	2021.09.30	2022.09.29
			MY55520006	2021.09.30	2022.09.29
			MY56120038	2021.09.30	2022.09.29
			MY56280002	2021.09.30	2022.09.29
Signal Analyzer	Agilent	N9020A	MY51110105	2021.03.04	2022.03.03
Temperature & Humidity	HH660	Mieo	N/A	2021.10.09	2022.10.08
Test SW	FARAD	EZ-EMC(Ver.STSLAB-03A1 RE)			





3. EMC EMISSION TEST

3.1 CONDUCTED EMISSION MEASUREMENT

3.1.1 POWER LINE CONDUCTED EMISSION LIMITS

The radio frequency voltage that is conducted back onto the AC power line on any frequency or frequencies, within the band 150 kHz to 30 MHz, shall not exceed the limits in the following table.

FREQUENCY (MHz)	Conducted Emission limit (dBuV)	
	Quasi-peak	Average
0.15 -0.5	66 - 56 *	56 - 46 *
0.50 -5.0	56.00	46.00
5.0 -30.0	60.00	50.00

Note:

- (1) The tighter limit applies at the band edges.
- (2) The limit of “ * ” marked band means the limitation decreases linearly with the logarithm of the frequency in the range.

The following table is the setting of the receiver

Receiver Parameters	Setting
Attenuation	10 dB
Start Frequency	0.15 MHz
Stop Frequency	30 MHz
IF Bandwidth	9 kHz

3.2 TEST PROCEDURE

- a. The EUT is 0.8 m from the horizontal ground plane and 0.4 m from the vertical ground plane with EUT being connected to the power mains through a line impedance stabilization network (LISN). All other support equipments are powered from additional LISN(s). The LISN provides 50 Ohm/ 50uH of coupling impedance for the measuring instrument.
- b. Interconnecting cables that hang closer than 40 cm to the ground plane shall be folded back and forth in the center forming a bundle 30 to 40 cm long.
- c. I/O cables that are not connected to a peripheral shall be bundled in the center. The end of the cable may be terminated, if required, using the correct terminating impedance. The overall length shall not exceed 1 m.
- d. LISN is at least 80 cm from the nearest part of EUT chassis.
- e. For the actual test configuration, please refer to the related Item –EUT Test Photos.

3.3 TEST SETUP

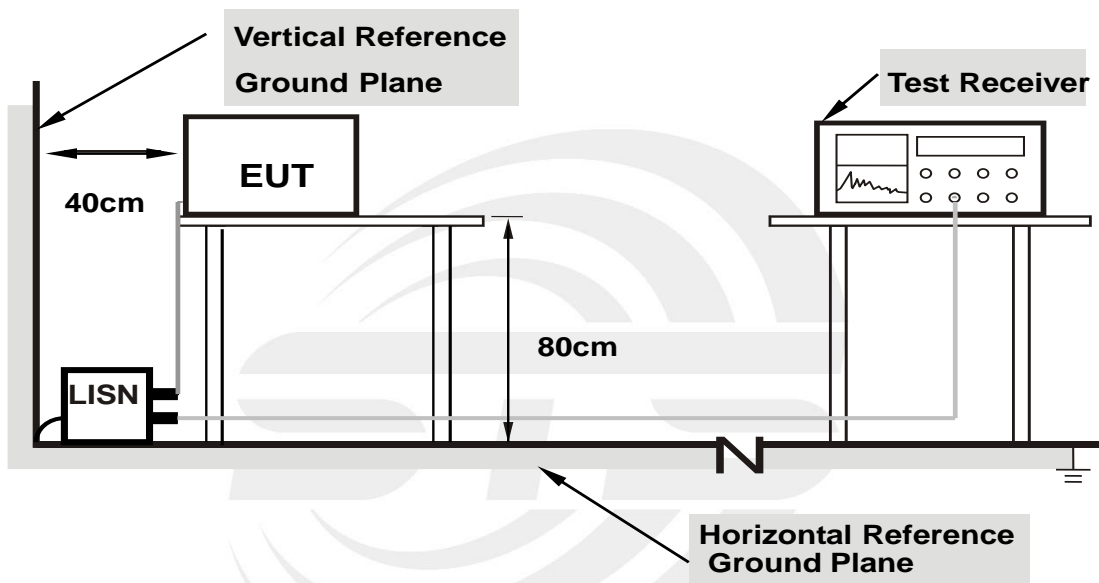

- Note: 1. Support units were connected to second LISN.**
2. Both of LISNs (AMN) are 80 cm from EUT and at least 80 cm from other units and other metal planes support units.

3.4 EUT OPERATING CONDITIONS

The EUT was configured for testing in a typical fashion (as a customer would normally use it). The EUT has been programmed to continuously transmit during test. This operating condition was tested and used to collect the included data.



3.5 TEST RESULTS

Temperature:	24.5(C)	Relative Humidity:	38%RH
Test Voltage:	AC 120V/60Hz	Phase:	L
Test Mode:	Mode 4		

No.	Frequency (MHz)	Reading (dBuV)	Correct Factor(dB)	Result (dBuV)	Limit (dBuV)	Margin (dB)	Remark
1	0.1500	26.43	20.33	46.76	66.00	-19.24	QP
2	0.1500	12.56	20.33	32.89	56.00	-23.11	AVG
3	0.4700	17.41	20.54	37.95	56.51	-18.56	QP
4	0.4700	5.58	20.54	26.12	46.51	-20.39	AVG
5	0.9460	9.85	20.31	30.16	56.00	-25.84	QP
6	0.9460	-1.36	20.31	18.95	46.00	-27.05	AVG
7	13.3580	12.21	21.55	33.76	60.00	-26.24	QP
8	13.3580	1.12	21.55	22.67	50.00	-27.33	AVG
9	23.1300	15.03	22.71	37.74	60.00	-22.26	QP
10	23.1300	8.61	22.71	31.32	50.00	-18.68	AVG
11	29.2340	14.99	22.88	37.87	60.00	-22.13	QP
12	29.2340	9.24	22.88	32.12	50.00	-17.88	AVG

Remark:

1. All readings are Quasi-Peak and Average values
2. Margin = Result (Result = Reading + Factor) – Limit
3. Factor=LISN factor+Cable loss+Limiter (10dB)

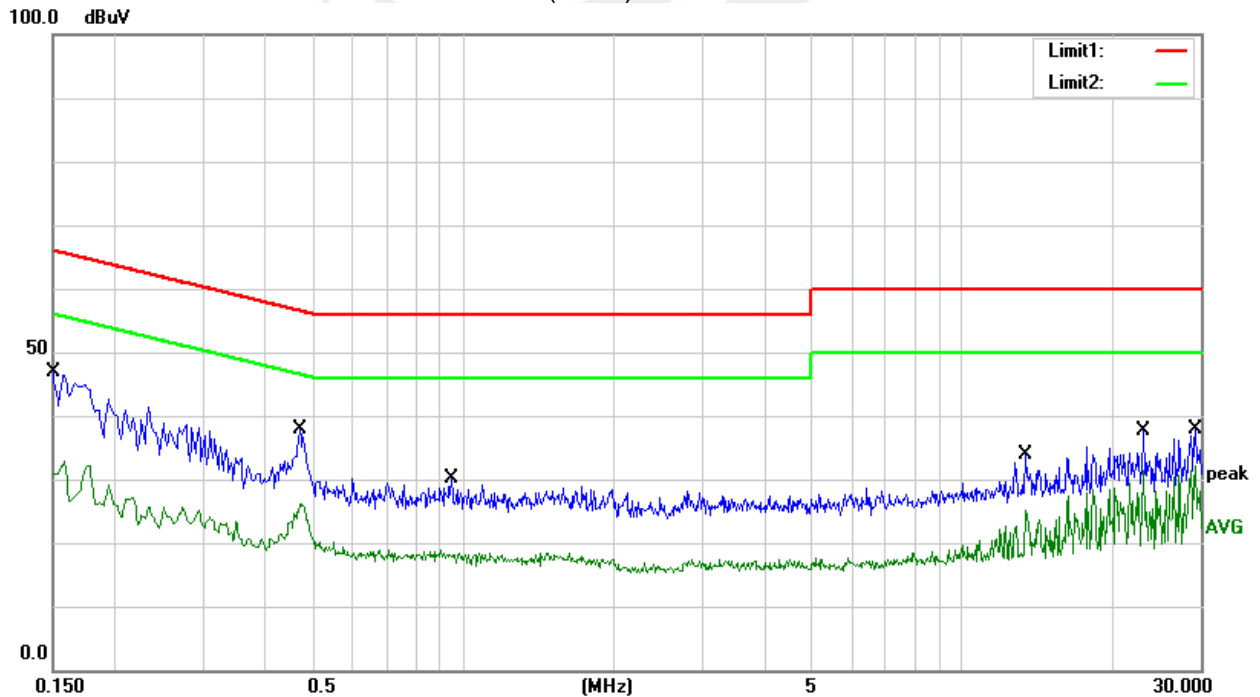



Temperature:	24.5(C)	Relative Humidity:	38%RH
Test Voltage:	AC 120V/60Hz	Phase:	N
Test Mode:	Mode 4		

No.	Frequency (MHz)	Reading (dBuV)	Correct Factor(dB)	Result (dBuV)	Limit (dBuV)	Margin (dB)	Remark
1	0.1580	24.07	20.33	44.40	65.57	-21.17	QP
2	0.1580	6.76	20.33	27.09	55.57	-28.48	AVG
3	0.3500	11.51	20.65	32.16	58.96	-26.80	QP
4	0.3500	0.71	20.65	21.36	48.96	-27.60	AVG
5	0.7100	8.89	20.35	29.24	56.00	-26.76	QP
6	0.7100	-1.43	20.35	18.92	46.00	-27.08	AVG
7	2.8420	6.38	20.35	26.73	56.00	-29.27	QP
8	2.8420	-3.21	20.35	17.14	46.00	-28.86	AVG
9	16.1660	10.64	22.00	32.64	60.00	-27.36	QP
10	16.1660	2.03	22.00	24.03	50.00	-25.97	AVG
11	29.2340	13.21	22.88	36.09	60.00	-23.91	QP
12	29.2340	7.35	22.88	30.23	50.00	-19.77	AVG

Remark:

1. All readings are Quasi-Peak and Average values
2. Margin = Result (Result =Reading + Factor)–Limit
3. Factor=LISN factor+Cable loss+Limiter (10dB)

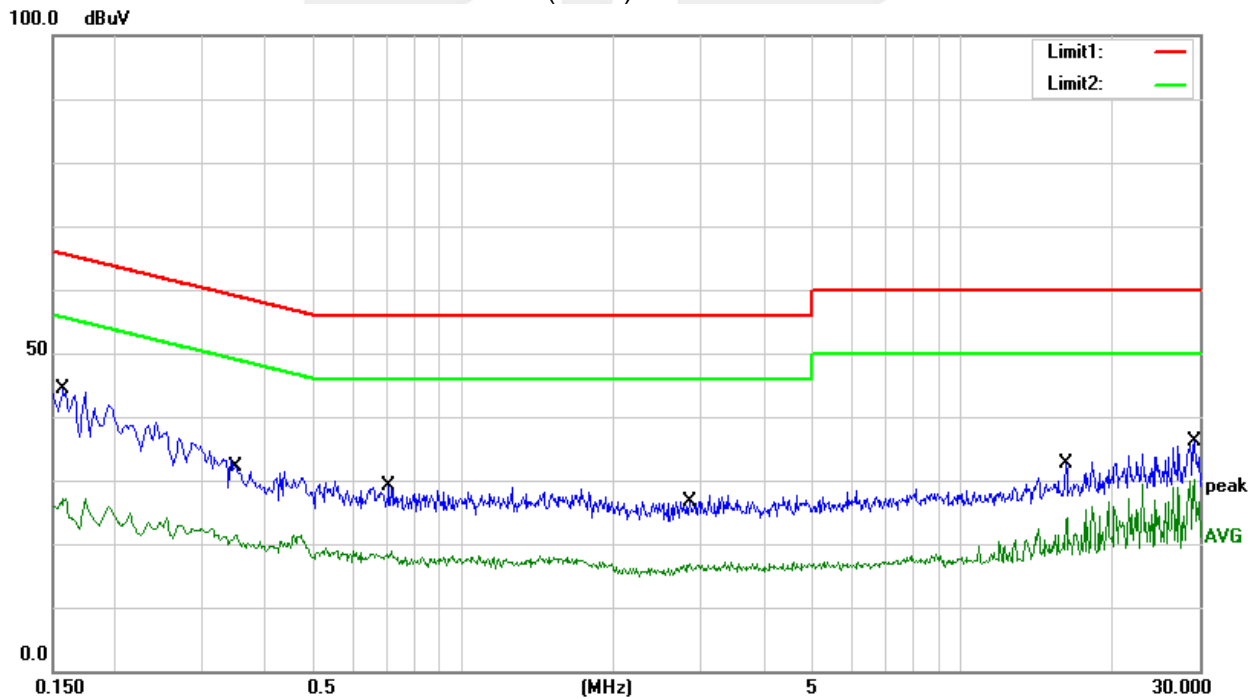



4. RADIATED EMISSION MEASUREMENT

4.1 RADIATED EMISSION LIMITS

In any 100 kHz bandwidth outside the operating frequency band. In case the emission fall within the Restricted band specified on Part15.205(a)&209(a) , RSS-Gen Issue 5 and RSS-247 Issue 2, February 2017 (5.5) limit in the table and according to ANSI C63.10-2013 below has to be followed.

LIMITS OF RADIATED EMISSION MEASUREMENT (Frequency Range 9kHz-1000MHz)

Frequencies (MHz)	Field Strength (micorvolts/meter)	Measurement Distance (meters)
0.009~0.490	2400/F(KHz)	300
0.490~1.705	24000/F(KHz)	30
1.705~30.0	30	30
30~88	100	3
88~216	150	3
216~960	200	3
Above 960	500	3

LIMITS OF RADIATED EMISSION MEASUREMENT (Above 1000MHz)

FREQUENCY (MHz)	(dBuV/m) (at 3M)	
	PEAK	AVERAGE
Above 1000	74	54

Notes:

- (1) The limit for radiated test was performed according to FCC PART 15C.
- (2) The tighter limit applies at the band edges.
- (3) Emission level (dBuV/m)=20log Emission level (uV/m).

LIMITS OF RESTRICTED FREQUENCY BANDS

FCC:

FREQUENCY (MHz)	FREQUENCY (MHz)	FREQUENCY (MHz)	FREQUENCY (GHz)
0.090-0.110	16.42-16.423	399.9-410	4.5-5.15
0.495-0.505	16.69475-16.69525	608-614	5.35-5.46
2.1735-2.1905	16.80425-16.80475	960-1240	7.25-7.75
4.125-4.128	25.5-25.67	1300-1427	8.025-8.5
4.17725-4.17775	37.5-38.25	1435-1626.5	9.0-9.2
4.20725-4.20775	73-74.6	1645.5-1646.5	9.3-9.5
6.215-6.218	74.8-75.2	1660-1710	10.6-12.7
6.26775-6.26825	108-121.94	1718.8-1722.2	13.25-13.4
6.31175-6.31225	123-138	2200-2300	14.47-14.5
8.291-8.294	149.9-150.05	2310-2390	15.35-16.2
8.362-8.366	156.52475-156.52525	2483.5-2500	17.7-21.4
8.37625-8.38675	156.7-156.9	2690-2900	22.01-23.12
8.41425-8.41475	162.0125-167.17	3260-3267	23.6-24.0
12.29-12.293	167.72-173.2	3332-3339	31.2-31.8
12.51975-12.52025	240-285	3345.8-3358	36.43-36.5
12.57675-12.57725	322-335.4	3600-4400	Above 38.6
13.36-13.41			



IC:

FREQUENCY (MHz)	FREQUENCY (MHz)	FREQUENCY (GHz)
0.090 - 0.110	149.9 - 150.05	9.0 - 9.2
0.495 - 0.505	156.52475 - 156.52525	9.3 - 9.5
2.1735 - 2.1905	156.7 - 156.9	10.6 - 12.7
3.020 - 3.026	162.0125 - 167.17	13.25 - 13.4
4.125 - 4.128	167.72 - 173.2	14.47 - 14.5
4.17725 - 4.17775	240 - 285	15.35 - 16.2
4.20725 - 4.20775	322 - 335.4	17.7 - 21.4
5.677 - 5.683	399.9 - 410	22.01 - 23.12
6.215 - 6.218	608 - 614	23.6 - 24.0
6.26775 - 6.26825	960 - 1427	31.2 - 31.8
6.31175 - 6.31225	1435 - 1626.5	36.43 - 36.5
8.291 - 8.294	1645.5 - 1646.5	Above 38.6
8.362 - 8.366	1660 - 1710	
8.37625 - 8.38675	1718.8 - 1722.2	
8.41425 - 8.41475	2200 - 2300	
12.29 - 12.293	2310 - 2390	
12.51975 - 12.52025	2483.5 - 2500	
12.57675 - 12.57725	2655 - 2900	
13.36 - 13.41	3260 - 3267	
16.42 - 16.423	3332 - 3339	
16.69475 - 16.69525	3345.8 - 3358	
16.80425 - 16.80475	3500 - 4400	
25.5 - 25.67	4500 - 5150	
37.5 - 38.25	5350 - 5460	
73 - 74.6	7250 - 7750	
74.8 - 75.2	8025 - 8500	
108 - 138		



For Radiated Emission

Spectrum Parameter	Setting
Attenuation	Auto
Detector	Peak/QP/AV
Start Frequency	9 KHz/150KHz(Peak/QP/AV)
Stop Frequency	150KHz/30MHz(Peak/QP/AV)
RB / VB (emission in restricted band)	200Hz (From 9kHz to 0.15MHz)/ 9KHz (From 0.15MHz to 30MHz); 200Hz (From 9kHz to 0.15MHz)/ 9KHz (From 0.15MHz to 30MHz)

Spectrum Parameter	Setting
Attenuation	Auto
Detector	Peak/QP
Start Frequency	30 MHz(Peak/QP)
Stop Frequency	1000 MHz (Peak/QP)
RB / VB (emission in restricted band)	120 KHz / 300 KHz

Spectrum Parameter	Setting
Attenuation	Auto
Detector	Peak/AV
Start Frequency	1000 MHz(Peak/AV)
Stop Frequency	10th carrier hamonic(Peak/AV)
RB / VB (emission in restricted band)	1 MHz / 3 MHz(Peak) 1 MHz/1/T MHz(AVG)

For Radited Band edge

Spectrum Parameter	Setting
Detector	Peak/AV
Start/Stop Frequency	Lower Band Edge: 890 to 920 MHz Upper Band Edge: 924 to 940 MHz
RB / VB	1 MHz / 3 MHz(Peak) 1 MHz/1/T MHz(AVG)



Receiver Parameter	Setting
Start ~ Stop Frequency	9kHz~90kHz / RB 200Hz for PK & AV
Start ~ Stop Frequency	90kHz~110kHz / RB 200Hz for QP
Start ~ Stop Frequency	110kHz~490kHz / RB 200Hz for PK & AV
Start ~ Stop Frequency	490kHz~30MHz / RB 9kHz for QP
Start ~ Stop Frequency	30MHz~1000MHz / RB 120kHz for QP

4.2 TEST PROCEDURE

- a. The measuring distance at 3 m shall be used for measurements at frequency 0.009MHz up to 1GHz, and above 1GHz.
- b. The EUT was placed on the top of a rotating table 0.8 m (above 1GHz is 1.5 m) above the ground at a 3 m anechoic chamber test site. The table was rotated 360 degree to determine the position of the highest radiation.
- c. The height of the equipment shall be 0.8 m (above 1GHz is 1.5 m); the height of the test antenna shall vary between 1 m to 4 m. Horizontal and vertical polarization of the antenna are set to make the measurement.
- d. The initial step in collecting conducted emission data is a spectrum analyzer peak detector mode pre-scanning the measurement frequency range. Significant peaks are then marked and QuasiPeak detector mode will be re-measured.
- e. If the Peak Mode measured value is compliance with and lower than Quasi Peak Mode Limit, the EUT shall be deemed to meet QP Limits and no additional QP Mode measurement was performed.
- f. For the actual test configuration, please refer to the related Item –EUT Test Photos.

Note:

Both horizontal and vertical antenna polarities were tested and performed pretest to three orthogonal axis. The worst case emissions were reported.

4.3 TEST SETUP

(A) Radiated Emission Test-Up Frequency Below 30MHz

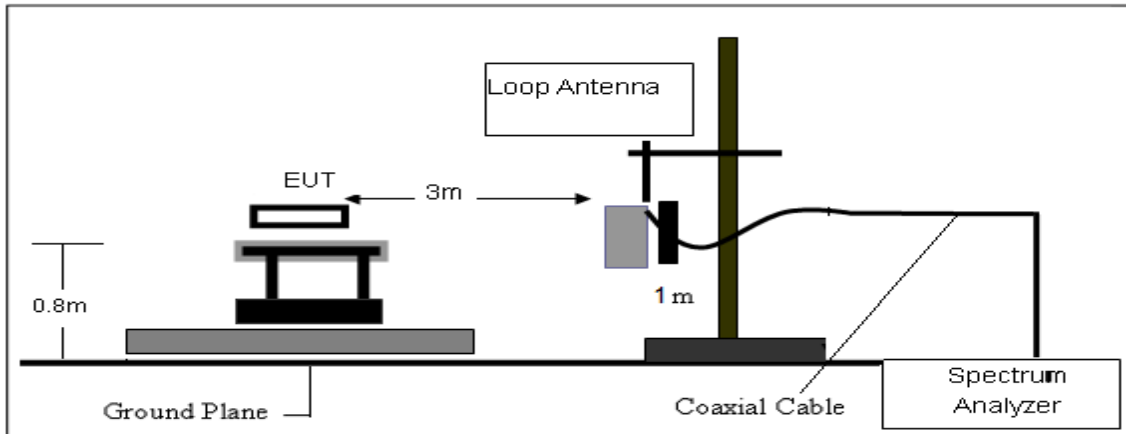

(B) Radiated Emission Test-Up Frequency 30MHz~1GHz

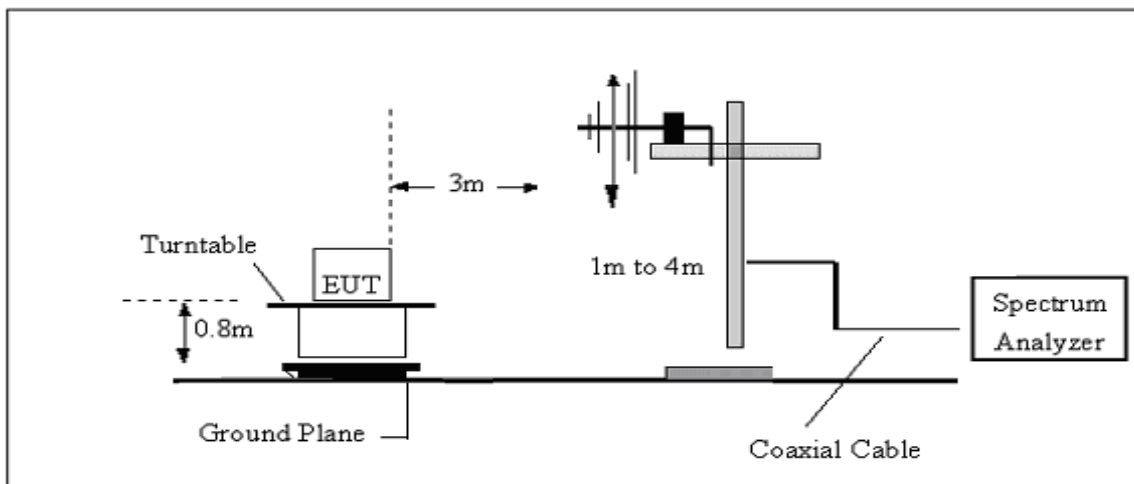

(C) Radiated Emission Test-Up Frequency Above 1GHz

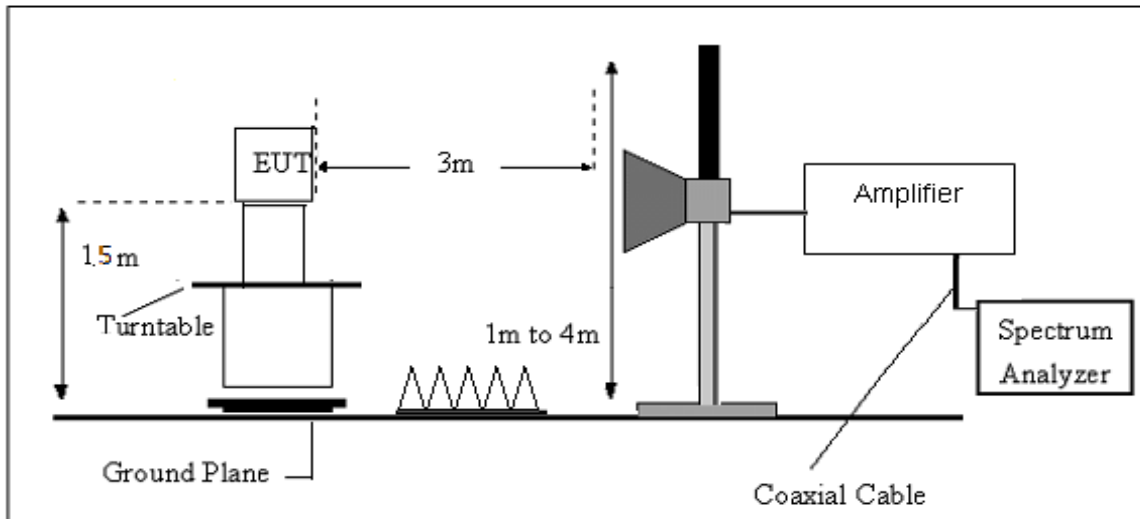

4.4 EUT OPERATING CONDITIONS

Please refer to section 3.4 of this report.



4.5 FIELD STRENGTH CALCULATION

The field strength is calculated by adding the Antenna Factor and Cable Factor and subtracting the Amplifier Gain and Duty Cycle Correction Factor (if any) from the measured reading. The basic equation with a sample calculation is as follows:

$$FS = RA + AF + CL - AG$$

Where

FS = Field Strength

CL = Cable Attenuation Factor (Cable Loss)

RA = Reading Amplitude

AG = Amplifier Gain

AF = Antenna Factor

For example

Frequency (MHz)	FS (dB μ V/m)	RA (dB μ V/m)	AF (dB)	CL (dB)	AG (dB)	Factor (dB)
300	40	58.1	12.2	1.6	31.9	-18.1

$$\text{Factor} = \text{AF} + \text{CL} - \text{AG}$$





4.6 TEST RESULTS

(Between 9KHz – 30 MHz)

Temperature:	23.1(C)	Relative Humidity:	60%RH
Test Voltage:	AC 120V/60Hz	Polarization:	--
Test Mode:	TX Mode		

Freq. (MHz)	Reading (dBuV/m)	Limit (dBuV/m)	Margin (dB)	State P/F
--	--	--	--	PASS
--	--	--	--	PASS

Note:

The amplitude of spurious emissions which are attenuated by more than 20dB below the permissible value has no need to be reported.

Distance extrapolation factor = $40 \log(\text{specific distance}/\text{test distance})(\text{dB})$;

Limit line = specific limits(dBuv) + distance extrapolation factor.

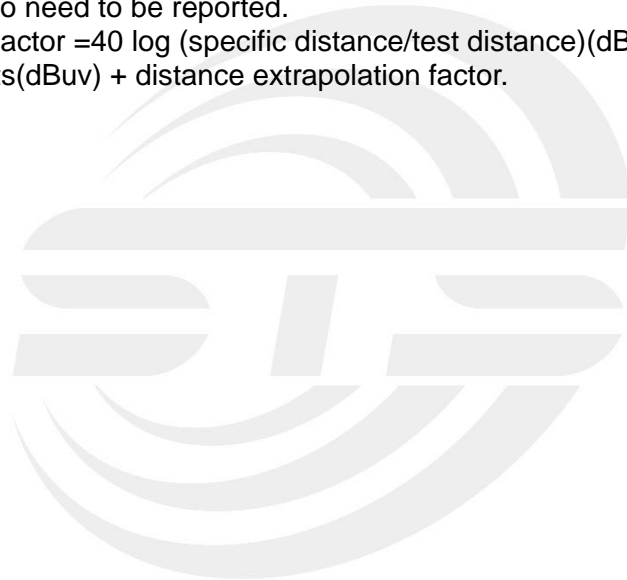



(30MHz -1000MHz)

Temperature:	23.1(C)	Relative Humidity:	60%RH
Test Voltage:	AC 120V/60Hz	Phase:	Horizontal
Test Mode:	Mode 1/2/3 (Mode 2 worst mode)		

No.	Frequency (MHz)	Reading (dBuV)	Correct Factor(dB/m)	Result (dBuV/m)	Limit (dBuV/m)	Margin (dB)	Remark
1	42.6100	46.66	-19.44	27.22	40.00	-12.78	QP
2	234.6700	47.92	-18.73	29.19	46.00	-16.81	QP
3	499.4800	41.59	-8.02	33.57	46.00	-12.43	QP
4	665.3500	30.62	-4.69	25.93	46.00	-20.07	QP
5	903.0000	104.09	-0.37	103.72	N/A	N/A	Fundamental
6	987.3900	29.65	2.21	31.86	54.00	-22.14	QP

Remark:

- Margin = Result (Result =Reading + Factor) –Limit
- Factor= Antenna factor+Cable attenuation factor(cable loss)-Amplifier gain

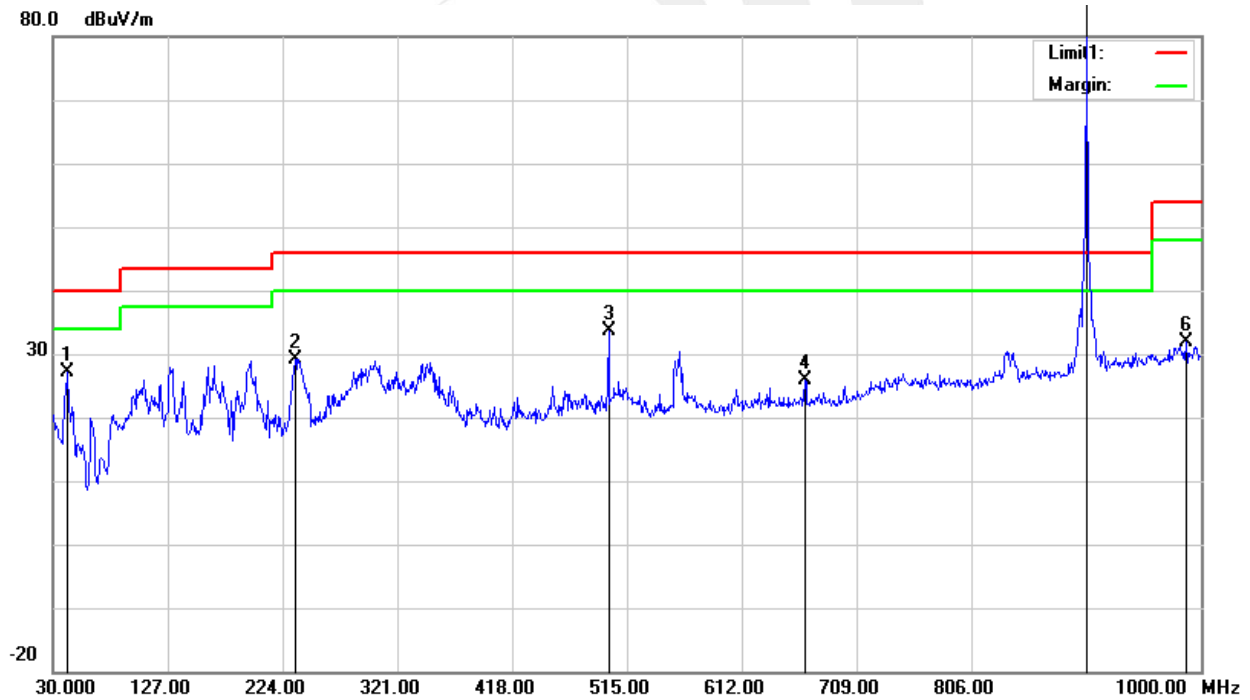



Temperature:	23.1(C)	Relative Humidity:	60%RH
Test Voltage:	AC 120V/60Hz	Phase:	Vertical
Test Mode:	Mode 1/2/3 (Mode 2 worst mode)		

No.	Frequency (MHz)	Reading (dBuV)	Correct Factor(dB/m)	Result (dBuV/m)	Limit (dBuV/m)	Margin (dB)	Remark
1	42.6100	56.82	-19.44	37.38	40.00	-2.62	QP
2	237.5800	50.23	-18.35	31.88	46.00	-14.12	QP
3	302.5700	47.24	-14.72	32.52	46.00	-13.48	QP
4	665.3500	33.33	-4.69	28.64	46.00	-17.36	QP
5	834.1300	41.42	-0.59	40.83	46.00	-5.17	QP
6	903.9700	105.68	-0.34	105.34	N/A	N/A	Fundamental

Remark:

- Margin = Result (Result =Reading + Factor)–Limit
- Factor= Antenna factor+Cable attenuation factor(cable loss)-Amplifier gain

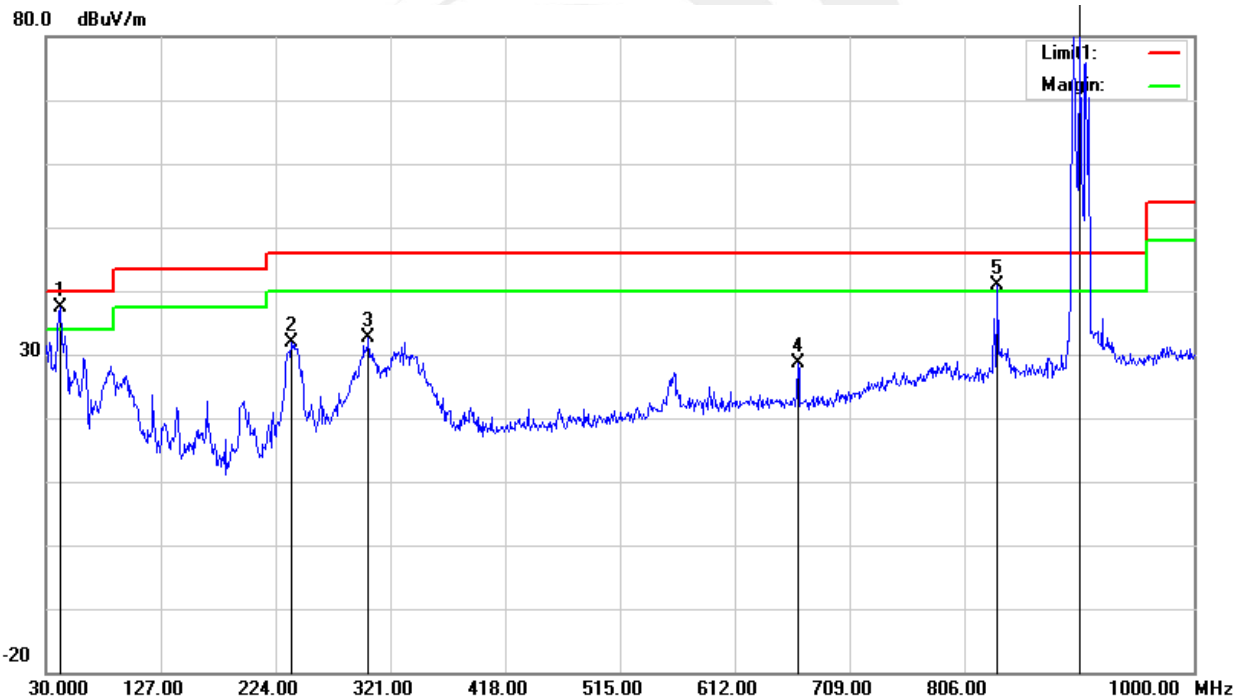



Above 1G Spurious emission Requirements

FSK

Frequency (MHz)	Meter Reading (dBμV)	Amplifier (dB)	Loss (dB)	Antenna Factor (dB/m)	Corrected Factor (dB)	Emission Level (dBμV/m)	Limits (dBμV/m)	Margin (dB)	Detector Type	Comment
Low Channel (FSK/903 MHz)										
1100.32	67.58	46.30	3.70	24.30	-18.30	49.28	74.00	-24.72	Pk	Vertical
1100.32	57.11	46.30	3.70	24.30	-18.30	38.81	54.00	-15.19	AV	Vertical
1100.60	67.57	46.30	3.70	24.30	-18.30	49.27	74.00	-24.73	Pk	Horizontal
1100.60	56.46	46.30	3.70	24.30	-18.30	38.16	54.00	-15.84	AV	Horizontal
1517.23	66.08	44.90	4.19	25.00	-15.71	50.37	74.00	-23.63	Pk	Vertical
1517.23	56.65	44.90	4.19	25.00	-15.71	40.94	54.00	-13.06	AV	Vertical
1517.43	65.31	44.90	4.19	25.00	-15.71	49.59	74.00	-24.41	Pk	Horizontal
1517.43	57.82	44.90	4.19	25.00	-15.71	42.11	54.00	-11.89	AV	Horizontal
1805.72	65.60	44.10	5.30	25.00	-13.80	51.80	74.00	-22.20	Pk	Vertical
1805.72	55.00	44.10	5.30	25.00	-13.80	41.20	54.00	-12.80	AV	Vertical
1805.28	64.59	44.10	5.30	25.00	-13.80	50.79	74.00	-23.21	Pk	Horizontal
1805.28	54.40	44.10	5.30	25.00	-13.80	40.60	54.00	-13.40	AV	Horizontal
2145.33	62.47	43.80	5.40	25.90	-12.50	49.97	74.00	-24.03	Pk	Vertical
2145.33	52.72	43.80	5.40	25.90	-12.50	40.22	54.00	-13.78	AV	Vertical
2145.66	62.77	43.80	5.40	25.90	-12.50	50.27	74.00	-23.73	Pk	Horizontal
2145.66	49.26	43.80	5.40	25.90	-12.50	36.77	54.00	-17.23	AV	Horizontal
2708.65	66.52	44.40	6.20	27.60	-10.60	55.92	74.00	-18.08	Pk	Vertical
2708.65	51.52	44.40	6.20	27.60	-10.60	40.92	54.00	-13.08	AV	Vertical
2708.79	65.15	44.40	6.20	27.60	-10.60	54.55	74.00	-19.45	Pk	Horizontal
2708.79	51.33	44.40	6.20	27.60	-10.60	40.73	54.00	-13.27	AV	Horizontal
3265.87	62.74	44.70	6.70	28.20	-9.80	52.94	74.00	-21.06	Pk	Vertical
3265.87	51.35	44.70	6.70	28.20	-9.80	41.55	54.00	-12.45	AV	Vertical
3265.95	62.20	44.70	6.70	28.20	-9.80	52.40	74.00	-21.60	Pk	Horizontal
3265.95	51.32	44.70	6.70	28.20	-9.80	41.52	54.00	-12.48	AV	Horizontal
4000.92	65.08	44.20	7.90	29.70	-6.60	58.48	74.00	-15.52	Pk	Vertical
4000.92	48.37	44.20	7.90	29.70	-6.60	41.77	54.00	-12.23	AV	Vertical
4000.92	68.10	44.20	7.90	29.70	-6.60	61.50	74.00	-12.50	Pk	Horizontal
4000.92	48.12	44.20	7.90	29.70	-6.60	41.52	54.00	-12.48	AV	Horizontal
7224.03	55.53	43.50	11.40	35.50	3.40	58.93	74.00	-15.07	Pk	Vertical
7224.03	38.80	43.50	11.40	35.50	3.40	42.20	54.00	-11.80	AV	Vertical
7224.03	55.21	43.50	11.40	35.50	3.40	58.61	74.00	-15.39	Pk	Horizontal
7224.03	39.31	43.50	11.40	35.50	3.40	42.71	54.00	-11.29	AV	Horizontal
8126.39	53.67	44.20	12.00	37.00	4.80	58.47	74.00	-15.53	Pk	Vertical
8126.39	38.23	44.20	12.00	37.00	4.80	43.03	54.00	-10.97	AV	Vertical
8126.41	53.63	44.20	12.00	37.00	4.80	58.43	74.00	-15.57	Pk	Horizontal
8126.41	38.15	44.20	12.00	37.00	4.80	42.95	54.00	-11.05	AV	Horizontal
9107.24	52.63	45.00	12.57	37.40	4.97	57.60	74.00	-16.40	Pk	Vertical
9107.24	41.03	45.00	12.57	37.40	4.97	46.00	54.00	-8.00	AV	Vertical
9107.45	53.50	45.00	12.57	37.40	4.97	58.46	74.00	-15.54	Pk	Horizontal
9107.45	38.74	45.00	12.57	37.40	4.97	43.71	54.00	-10.29	AV	Horizontal
9932.94	48.63	43.60	14.33	39.50	10.20	58.83	74.00	-15.17	Pk	Vertical
9932.94	33.27	43.60	14.33	39.50	10.20	43.47	54.00	-10.53	AV	Vertical
9932.96	51.18	43.60	14.33	39.50	10.20	61.38	74.00	-12.62	Pk	Horizontal
9932.96	35.11	43.60	14.33	39.50	10.20	45.31	54.00	-8.69	AV	Horizontal



Middle Channel (FSK/915 MHz)										
1100.05	67.63	46.30	3.70	24.30	-18.30	49.33	74.00	-24.67	Pk	Vertical
1100.05	56.61	46.30	3.70	24.30	-18.30	38.31	54.00	-15.69	AV	Vertical
1100.37	67.64	46.30	3.70	24.30	-18.30	49.34	74.00	-24.66	Pk	Horizontal
1100.37	56.24	46.30	3.70	24.30	-18.30	37.94	54.00	-16.06	AV	Horizontal
1517.37	65.19	44.90	4.19	25.00	-15.71	49.48	74.00	-24.52	Pk	Vertical
1517.37	56.49	44.90	4.19	25.00	-15.71	40.78	54.00	-13.22	AV	Vertical
1517.41	65.93	44.90	4.19	25.00	-15.71	50.22	74.00	-23.78	Pk	Horizontal
1517.41	56.98	44.90	4.19	25.00	-15.71	41.27	54.00	-12.73	AV	Horizontal
1829.83	65.20	44.10	5.30	25.00	-13.80	51.40	74.00	-22.60	Pk	Vertical
1829.83	54.66	44.10	5.30	25.00	-13.80	40.86	54.00	-13.14	AV	Vertical
1829.47	65.04	44.10	5.30	25.00	-13.80	51.24	74.00	-22.76	Pk	Horizontal
1829.47	53.57	44.10	5.30	25.00	-13.80	39.77	54.00	-14.23	AV	Horizontal
2145.43	62.39	43.80	5.40	25.90	-12.50	49.89	74.00	-24.11	Pk	Vertical
2145.43	52.63	43.80	5.40	25.90	-12.50	40.14	54.00	-13.86	AV	Vertical
2145.58	62.94	43.80	5.40	25.90	-12.50	50.45	74.00	-23.55	Pk	Horizontal
2145.58	50.16	43.80	5.40	25.90	-12.50	37.66	54.00	-16.34	AV	Horizontal
2744.66	67.61	44.40	6.20	27.60	-10.60	57.01	74.00	-16.99	Pk	Vertical
2744.66	50.74	44.40	6.20	27.60	-10.60	40.14	54.00	-13.86	AV	Vertical
2744.64	64.61	44.40	6.20	27.60	-10.60	54.01	74.00	-19.99	Pk	Horizontal
2744.64	51.14	44.40	6.20	27.60	-10.60	40.54	54.00	-13.46	AV	Horizontal
3265.95	62.44	44.70	6.70	28.20	-9.80	52.64	74.00	-21.36	Pk	Vertical
3265.95	51.05	44.70	6.70	28.20	-9.80	41.25	54.00	-12.75	AV	Vertical
3265.89	63.04	44.70	6.70	28.20	-9.80	53.24	74.00	-20.76	Pk	Horizontal
3265.89	51.05	44.70	6.70	28.20	-9.80	41.25	54.00	-12.75	AV	Horizontal
4001.05	64.95	44.20	7.90	29.70	-6.60	58.35	74.00	-15.65	Pk	Vertical
4001.05	47.80	44.20	7.90	29.70	-6.60	41.20	54.00	-12.80	AV	Vertical
4001.08	68.49	44.20	7.90	29.70	-6.60	61.89	74.00	-12.11	Pk	Horizontal
4001.08	48.91	44.20	7.90	29.70	-6.60	42.31	54.00	-11.69	AV	Horizontal
7319.96	56.18	43.50	11.40	35.50	3.40	59.58	74.00	-14.42	Pk	Vertical
7319.96	38.08	43.50	11.40	35.50	3.40	41.48	54.00	-12.52	AV	Vertical
7319.93	55.13	43.50	11.40	35.50	3.40	58.53	74.00	-15.47	Pk	Horizontal
7319.93	38.41	43.50	11.40	35.50	3.40	41.81	54.00	-12.19	AV	Horizontal
8126.40	54.10	44.20	12.00	37.00	4.80	58.90	74.00	-15.10	Pk	Vertical
8126.40	38.05	44.20	12.00	37.00	4.80	42.85	54.00	-11.15	AV	Vertical
8126.34	54.10	44.20	12.00	37.00	4.80	58.90	74.00	-15.10	Pk	Horizontal
8126.34	38.62	44.20	12.00	37.00	4.80	43.42	54.00	-10.58	AV	Horizontal
9149.19	52.67	45.00	12.57	37.40	4.97	57.63	74.00	-16.37	Pk	Vertical
9149.19	40.73	45.00	12.57	37.40	4.97	45.70	54.00	-8.30	AV	Vertical
9149.36	53.51	45.00	12.57	37.40	4.97	58.48	74.00	-15.52	Pk	Horizontal
9149.36	39.39	45.00	12.57	37.40	4.97	44.35	54.00	-9.65	AV	Horizontal
9932.88	49.54	43.60	14.33	39.50	10.20	59.74	74.00	-14.26	Pk	Vertical
9932.88	33.80	43.60	14.33	39.50	10.20	44.00	54.00	-10.00	AV	Vertical
9932.84	51.32	43.60	14.33	39.50	10.20	61.52	74.00	-12.48	Pk	Horizontal
9932.84	36.04	43.60	14.33	39.50	10.20	46.24	54.00	-7.76	AV	Horizontal



High Channel (FSK/927 MHz)										
1098.95	67.97	46.30	3.70	24.30	-18.30	49.67	74.00	-24.33	Pk	Vertical
1098.95	56.24	46.30	3.70	24.30	-18.30	37.94	54.00	-16.06	AV	Vertical
1099.26	68.28	46.30	3.70	24.30	-18.30	49.98	74.00	-24.02	Pk	Horizontal
1099.26	56.47	46.30	3.70	24.30	-18.30	38.17	54.00	-15.83	AV	Horizontal
1515.62	65.42	44.90	4.19	25.00	-15.71	49.70	74.00	-24.30	Pk	Vertical
1515.62	56.36	44.90	4.19	25.00	-15.71	40.65	54.00	-13.35	AV	Vertical
1515.68	65.26	44.90	4.19	25.00	-15.71	49.55	74.00	-24.45	Pk	Horizontal
1515.68	57.37	44.90	4.19	25.00	-15.71	41.66	54.00	-12.34	AV	Horizontal
1853.67	65.31	44.10	5.30	25.00	-13.80	51.51	74.00	-22.49	Pk	Vertical
1853.67	54.90	44.10	5.30	25.00	-13.80	41.10	54.00	-12.90	AV	Vertical
1853.34	64.68	44.10	5.30	25.00	-13.80	50.88	74.00	-23.12	Pk	Horizontal
1853.34	54.26	44.10	5.30	25.00	-13.80	40.46	54.00	-13.54	AV	Horizontal
2143.24	62.68	43.80	5.40	25.90	-12.50	50.18	74.00	-23.82	Pk	Vertical
2143.24	53.00	43.80	5.40	25.90	-12.50	40.51	54.00	-13.49	AV	Vertical
2143.41	63.20	43.80	5.40	25.90	-12.50	50.70	74.00	-23.30	Pk	Horizontal
2143.41	49.59	43.80	5.40	25.90	-12.50	37.10	54.00	-16.90	AV	Horizontal
2780.61	66.94	44.40	6.20	27.60	-10.60	56.34	74.00	-17.66	Pk	Vertical
2780.61	50.32	44.40	6.20	27.60	-10.60	39.72	54.00	-14.28	AV	Vertical
2780.56	64.88	44.40	6.20	27.60	-10.60	54.28	74.00	-19.72	Pk	Horizontal
2780.56	50.13	44.40	6.20	27.60	-10.60	39.53	54.00	-14.47	AV	Horizontal
3262.20	63.11	44.70	6.70	28.20	-9.80	53.31	74.00	-20.69	Pk	Vertical
3262.20	51.11	44.70	6.70	28.20	-9.80	41.31	54.00	-12.69	AV	Vertical
3262.42	63.38	44.70	6.70	28.20	-9.80	53.58	74.00	-20.42	Pk	Horizontal
3262.42	50.83	44.70	6.70	28.20	-9.80	41.03	54.00	-12.97	AV	Horizontal
3996.57	64.38	44.20	7.90	29.70	-6.60	57.78	74.00	-16.22	Pk	Vertical
3996.57	47.67	44.20	7.90	29.70	-6.60	41.07	54.00	-12.93	AV	Vertical
3996.72	68.07	44.20	7.90	29.70	-6.60	61.47	74.00	-12.53	Pk	Horizontal
3996.72	49.36	44.20	7.90	29.70	-6.60	42.76	54.00	-11.24	AV	Horizontal
7415.94	56.17	43.50	11.40	35.50	3.40	59.57	74.00	-14.43	Pk	Vertical
7415.94	38.34	43.50	11.40	35.50	3.40	41.74	54.00	-12.26	AV	Vertical
7416.00	55.37	43.50	11.40	35.50	3.40	58.77	74.00	-15.23	Pk	Horizontal
7416.00	39.30	43.50	11.40	35.50	3.40	42.70	54.00	-11.30	AV	Horizontal
8117.55	53.99	44.20	12.00	37.00	4.80	58.79	74.00	-15.21	Pk	Vertical
8117.55	37.37	44.20	12.00	37.00	4.80	42.17	54.00	-11.83	AV	Vertical
8117.55	54.31	44.20	12.00	37.00	4.80	59.11	74.00	-14.89	Pk	Horizontal
8117.55	38.01	44.20	12.00	37.00	4.80	42.81	54.00	-11.19	AV	Horizontal
9269.27	52.77	45.00	12.57	37.40	4.97	57.74	74.00	-16.26	Pk	Vertical
9269.27	41.03	45.00	12.57	37.40	4.97	46.00	54.00	-8.00	AV	Vertical
9269.25	53.44	45.00	12.57	37.40	4.97	58.40	74.00	-15.60	Pk	Horizontal
9269.25	39.39	45.00	12.57	37.40	4.97	44.36	54.00	-9.64	AV	Horizontal
9921.94	49.13	43.60	14.33	39.50	10.20	59.33	74.00	-14.67	Pk	Vertical
9921.94	34.55	43.60	14.33	39.50	10.20	44.75	54.00	-9.25	AV	Vertical
9921.98	52.18	43.60	14.33	39.50	10.20	62.38	74.00	-11.62	Pk	Horizontal
9921.98	35.88	43.60	14.33	39.50	10.20	46.08	54.00	-7.92	AV	Horizontal

Note:

1) Factor = Antenna Factor + Cable Loss – Pre-amplifier.

Emission Level = Reading + Factor

2) The frequency emission of peak points that did not show above the forms are at least 20dB below the limit, the frequency emission is mainly from the environment noise.



4.6 TEST RESULTS (Radited Band edge Requirements)

Note: The main frequency is too far away from the restricted band and does not require testing.



5. CONDUCTED SPURIOUS & BAND EDGE EMISSION

5.1 LIMIT

According to FCC section 15.247(d)&RSS-247 Issue 2, in any 100kHz bandwidth outside the frequency band in which the spread spectrum or digitally modulated intentional radiator is operating, the radio frequency power that is produced by the intentional radiator shall be at least 20dB below that in the 100kHz bandwidth within the band that contains the highest level of the desired power, based on either an RF conducted or a radiated measurement.

5.2 TEST PROCEDURE

Spectrum Parameter	Setting
Detector	Peak
Start/Stop Frequency	30 MHz to 10th carrier harmonic
RB / VB (emission in restricted band)	100 KHz/300 KHz
Trace-Mode:	Max hold

For Band edge

Spectrum Parameter	Setting
Detector	Peak
Start/Stop Frequency	Lower Band Edge: 850-922 MHz Upper Band Edge: 924-950 MHz
RB / VB (emission in restricted band)	100 KHz/300 KHz
Trace-Mode:	Max hold

5.3 TEST SETUP



The EUT which is powered by the Battery, is connected to the Spectrum Analyzer; the RF load attached to the EUT antenna terminal is 50 Ohm; the path loss as the factor is calibrated to correct the reading. Make the measurement with the spectrum analyzer's resolution bandwidth(RBW) = 100 kHz. In order to make an accurate measurement, set the span greater than RBW.

5.4 EUT OPERATION CONDITIONS

Please refer to section 3.4 of this report.



5.5 TEST RESULTS

Temperature:	25 °C	Relative Humidity:	50%
Test Voltage:	AC 120V/60Hz	Test Mode:	TX Mode /CH01, CH21, CH41

01 CH

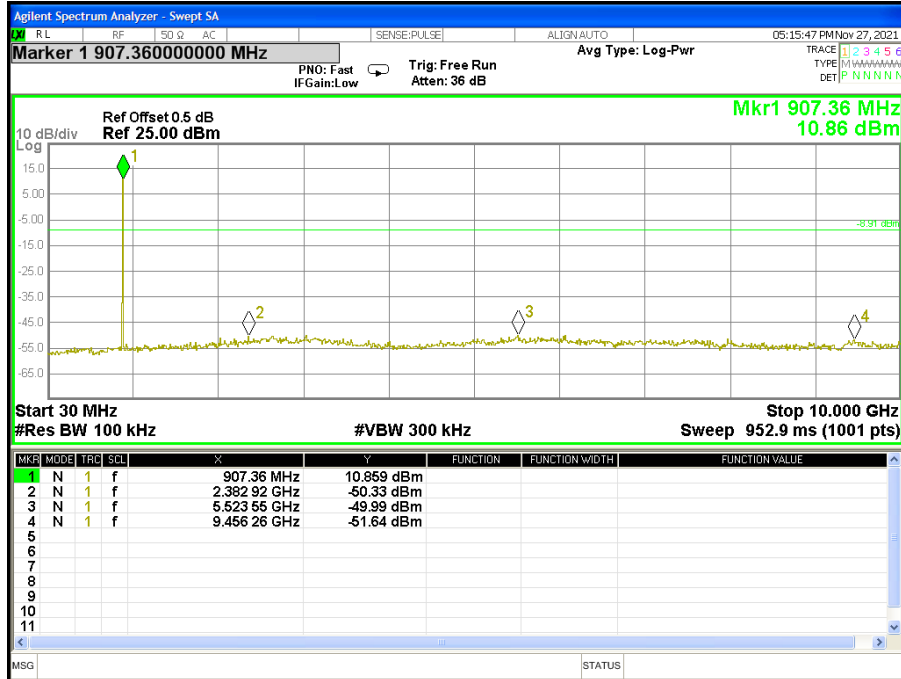



21 CH

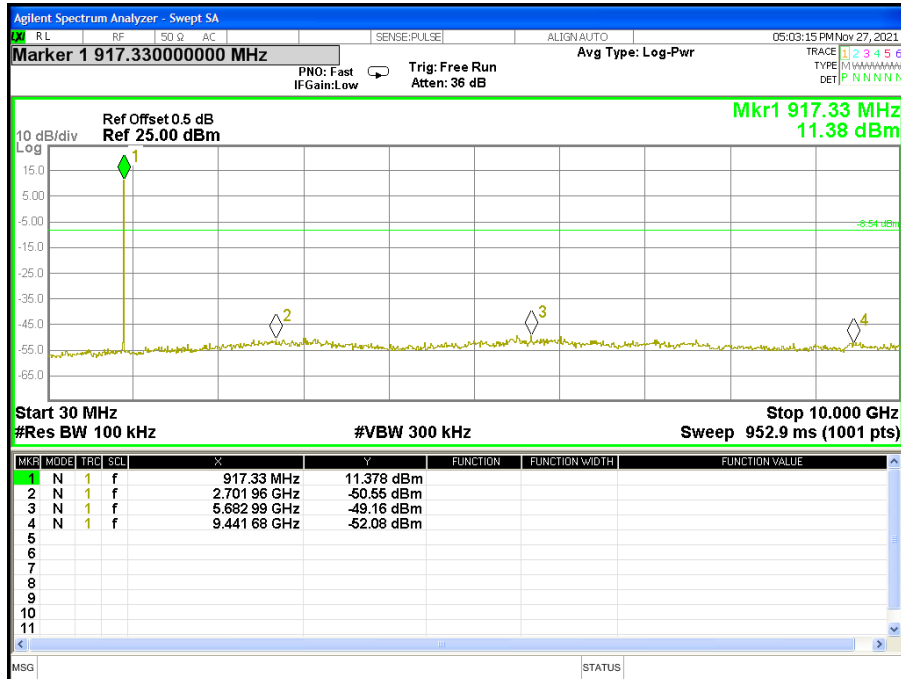

41 CH

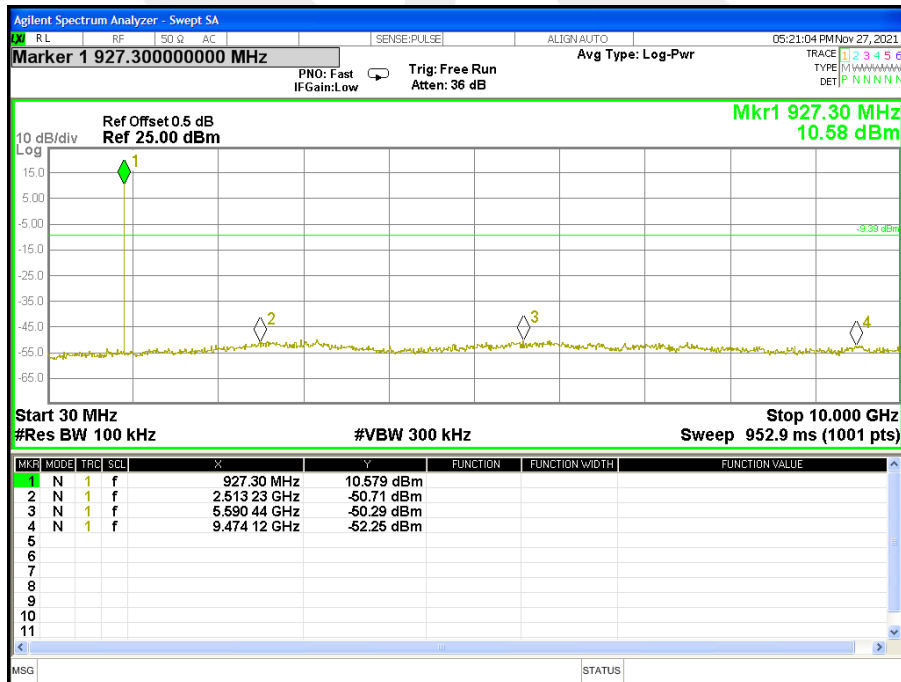



For Band edge(it's also the reference level for conducted spurious emission)

01 CH

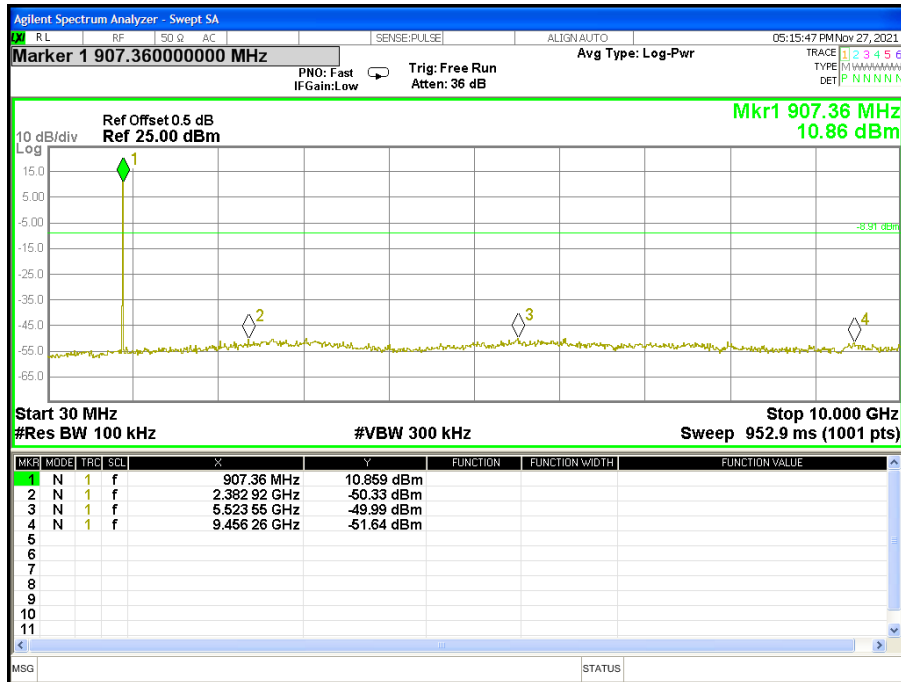

21 CH

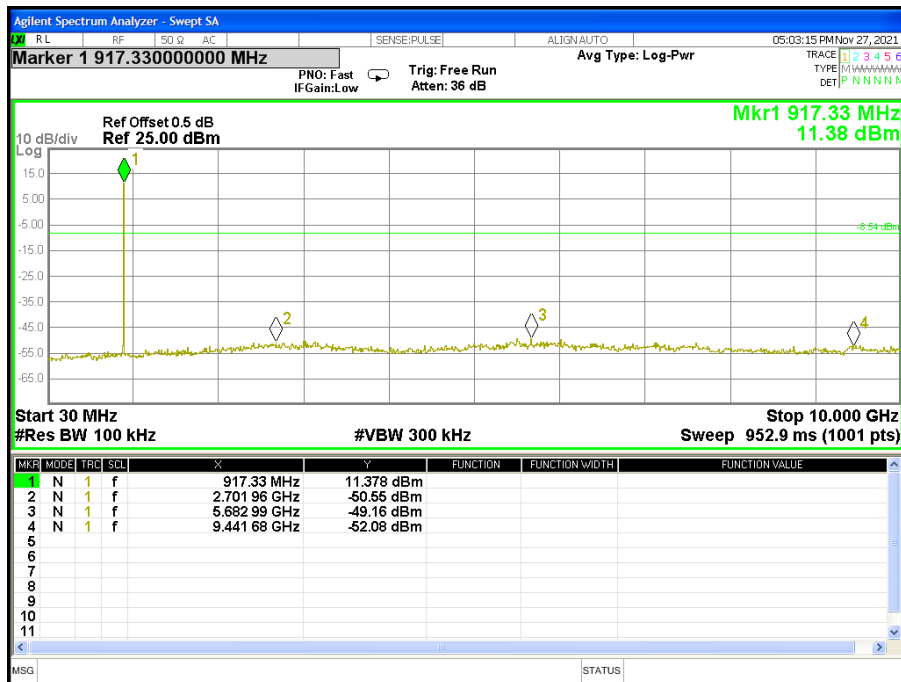



41 CH

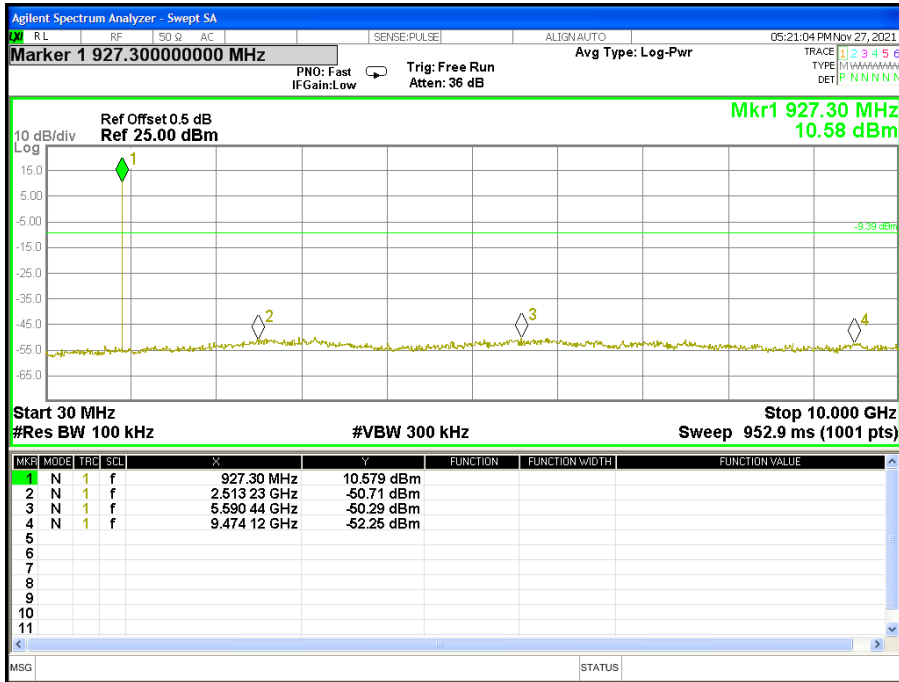

6. POWER SPECTRAL DENSITY TEST

6.1 LIMIT

FCC Part 15.247, Subpart C RSS-247 Issue 2				
Section	Test Item	Limit	Frequency Range (MHz)	Result
15.247(e) RSS-247 Issue 2	Power Spectral Density	≤ 8 dBm (RBW ≥ 3 KHz)	902-928	PASS

6.2 TEST PROCEDURE

1. Set analyzer center frequency to DTS channel center frequency.
2. Set the span to 1.5 times the DTS channel bandwidth.
3. Set the RBW to: $100 \text{ kHz} \geq \text{RBW} \geq 3 \text{ kHz}$.
4. Set the VBW $\geq 3 \times \text{RBW}$.
5. Detector = peak.
6. Sweep time = auto couple.
7. Trace mode = max hold.
8. Allow trace to fully stabilize.
9. Use the peak marker function to determine the maximum amplitude level.
10. If measured value exceeds limit, reduce RBW (no less than 3 kHz) and repeat.

6.3 TEST SETUP



6.4 EUT OPERATION CONDITIONS

Please refer to section 3.4 of this report.



6.5 TEST RESULTS

Temperature:	25 °C	Relative Humidity:	60%
Test Voltage:	AC 120V/60Hz	Test Mode:	TX Mode /CH01, CH21, CH41

Modulation	Frequency (MHz)	Power Density (dBm/3kHz)	Limit (dBm/3KHz)	Result
FSK	903	-6.790	8	PASS
	915	-6.440	8	PASS
	927	-7.350	8	PASS

TX CH01

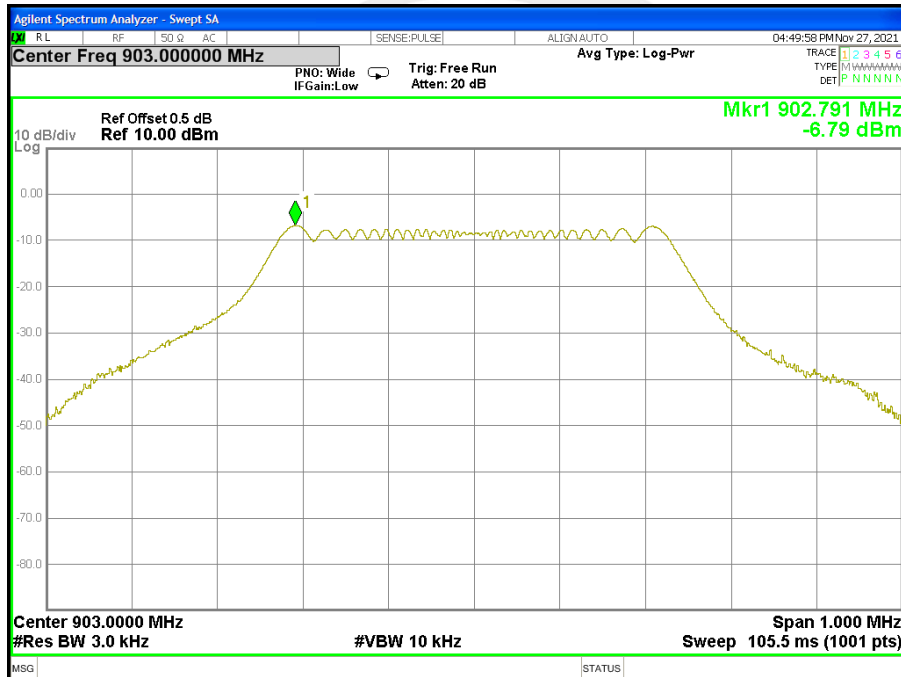



TX CH21

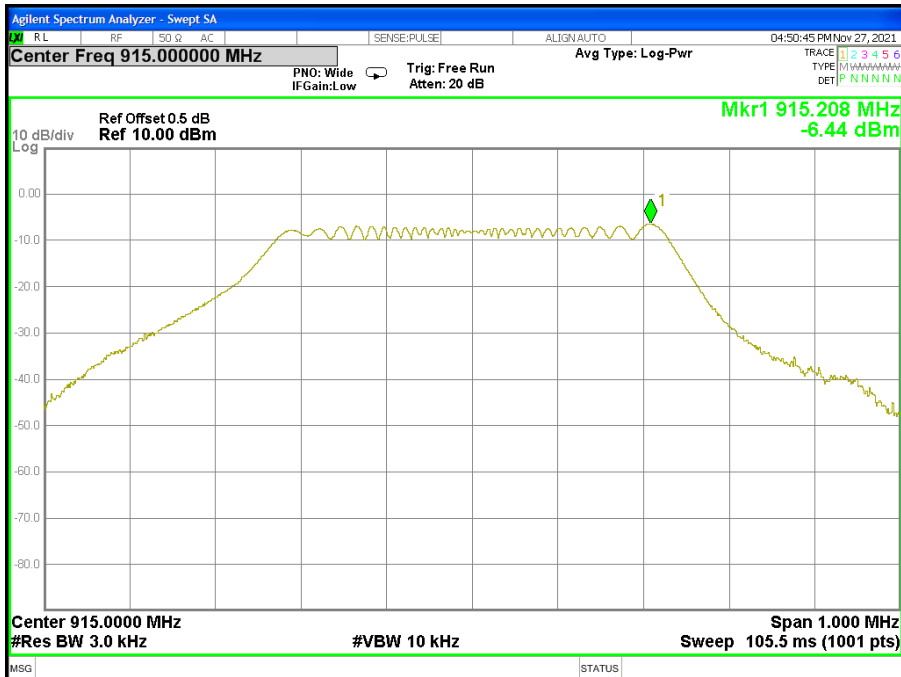

TX CH41

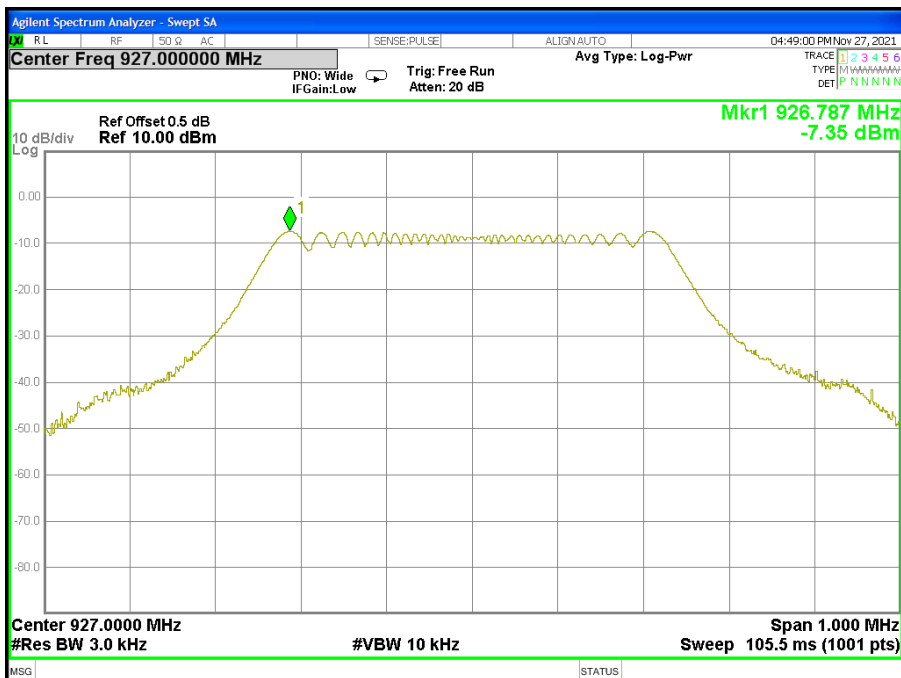

7. BANDWIDTH TEST

7.1 LIMIT

FCC Part 15.247, Subpart C RSS-Gen Clause 6.7				
Section	Test Item	Limit	Frequency Range (MHz)	Result
15.247(a)(2) RSS-247 5.2 (a)	Bandwidth	$\geq 500\text{KHz}$ (6dB bandwidth)	902-928	PASS
RSS-Gen Clause 6.7	99% Bandwidth	For reporting purposes only.	902-928	PASS

7.2 TEST PROCEDURE

The automatic bandwidth measurement capability of an instrument may be employed using the X dB bandwidth mode with X set to 6 dB, if the functionality described above (i.e., RBW = 100 kHz, VBW ≥ 3 RBW, peak detector with maximum hold) is implemented by the instrumentation function. When using this capability, care shall be taken so that the bandwidth measurement is not influenced by any intermediate power nulls in the fundamental emission that might be ≥ 6 dB.

7.3 TEST SETUP



7.4 EUT OPERATION CONDITIONS

Please refer to section 3.4 of this report.



7.5 TEST RESULTS

Temperature:	25 °C	Relative Humidity:	60%
Test Voltage:	AC 120V/60Hz	Test Mode:	TX Mode /CH01, CH21, CH41

Frequency	6dB Bandwidth (KHz)	99% Bandwidth (KHz)	6dB Bandwidth Limit(KHz)	Result
903 MHz	620.000	507.340	≥500KHz	PASS
915 MHz	622.600	531.110	≥500KHz	PASS
927 MHz	633.900	520.630	≥500KHz	PASS

6dB Bandwidth TX CH 01

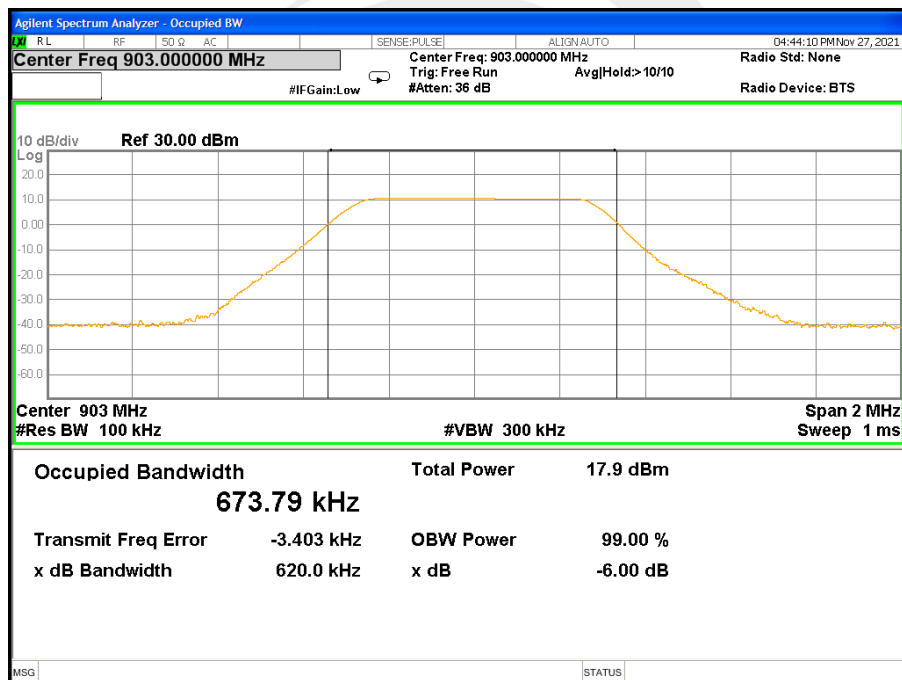



6dB Bandwidth TX CH 21

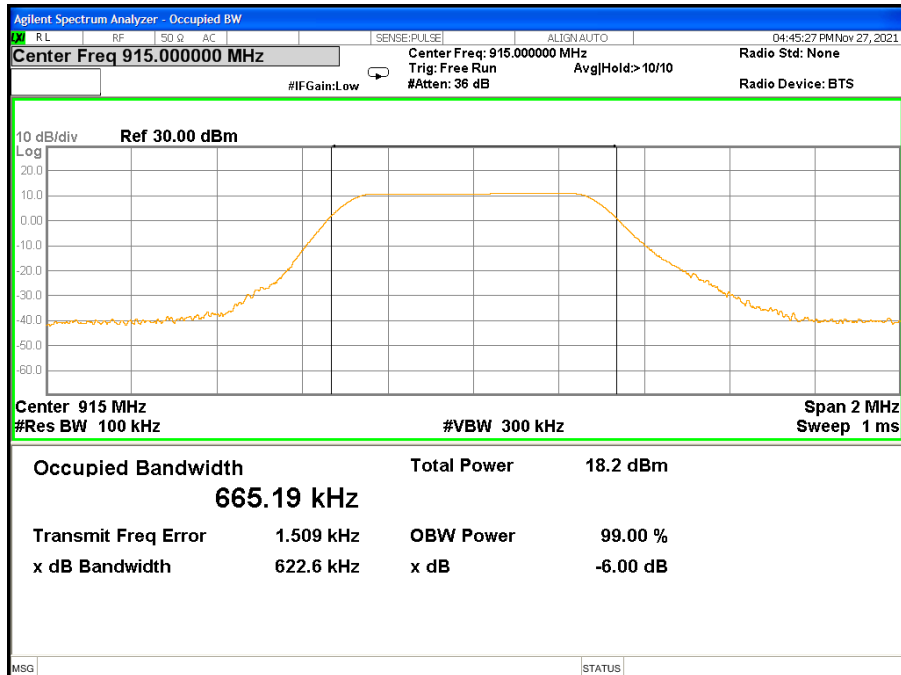

6dB Bandwidth TX CH 41

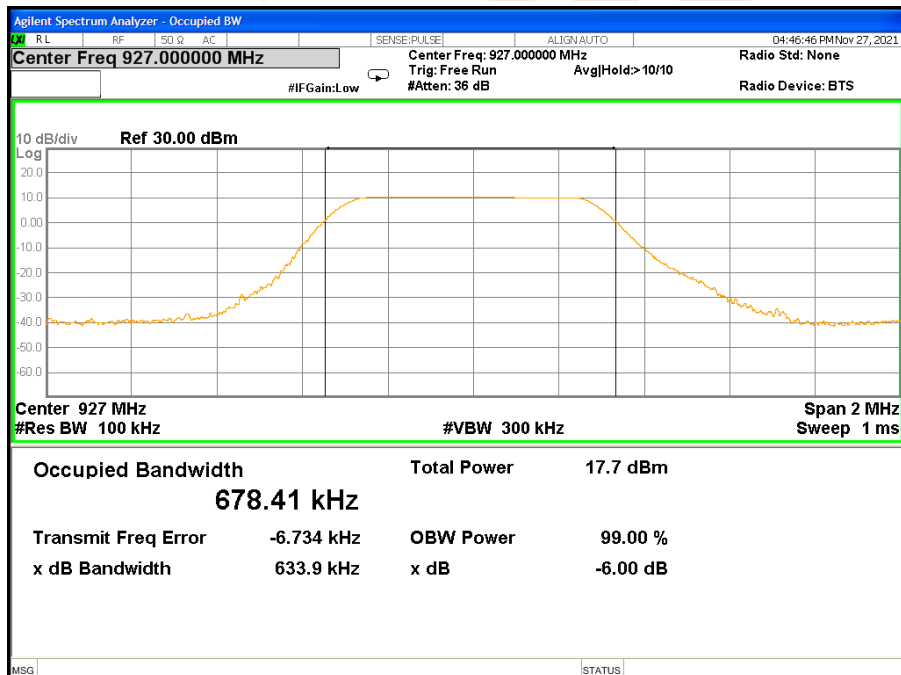



99% Bandwidth TX CH 01

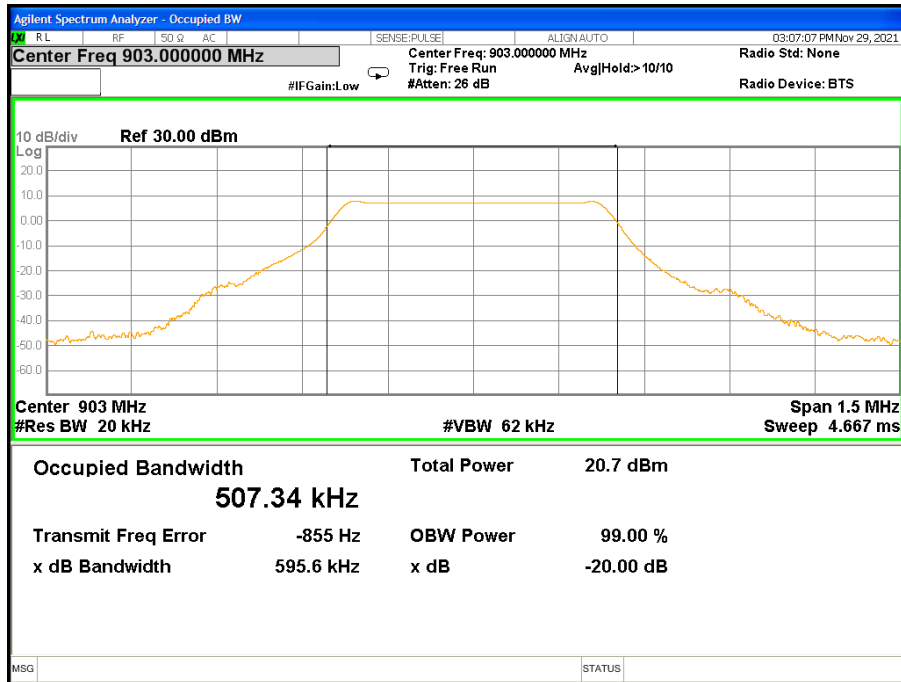

99% Bandwidth TX CH 21

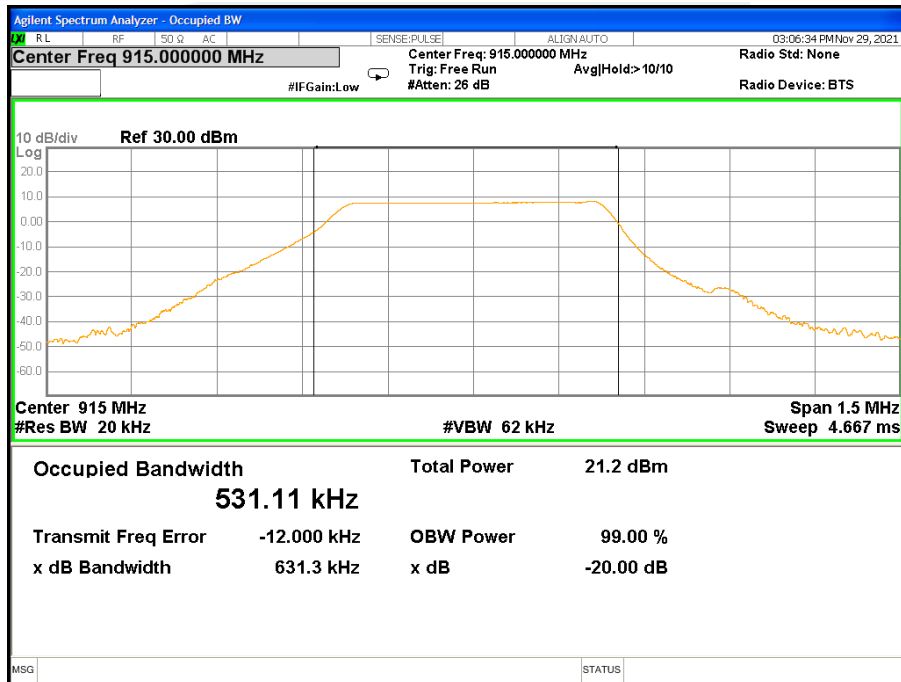



99% Bandwidth TX CH 41

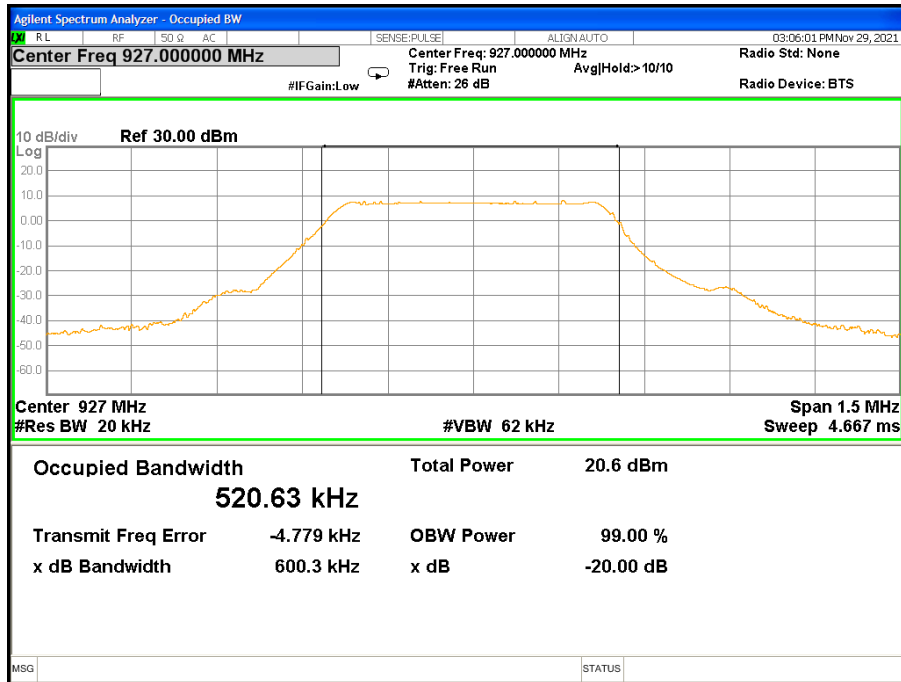



8. PEAK OUTPUT POWER TEST

8.1 LIMIT

FCC Part 15.247, Subpart C				
Section	Test Item	Limit	Frequency Range (MHz)	Result
15.247(b)(3) RSS 247 Issue 2	Output Power	1 watt or 30dBm	902-928	PASS
RSS-247	EIRP	4W	902-928	PASS

8.2 TEST PROCEDURE

One of the following procedures may be used to determine the maximum peak conducted output power of a DTS EUT.

RBW \geq DTS bandwidth

The following procedure shall be used when an instrument with a resolution bandwidth that is greater than the DTS bandwidth is available to perform the measurement:

- Set the RBW \geq DTS bandwidth.
- Set VBW \geq [3 \times RBW].
- Set span \geq [3 \times RBW].
- Sweep time = auto couple.
- Detector = peak.
- Trace mode = max hold.
- Allow trace to fully stabilize.
- Use peak marker function to determine the peak amplitude level.

Integrated band power method:

The following procedure can be used when the maximum available RBW of the instrument is less than the

DTS bandwidth:

- Set the RBW = 1 MHz.
- Set the VBW \geq [3 \times RBW].
- Set the span \geq [1.5 \times DTS bandwidth].
- Detector = peak.
- Sweep time = auto couple.
- Trace mode = max hold.
- Allow trace to fully stabilize.
- Use the instrument's band/channel power measurement function with the band limits set equal to the DTS bandwidth edges (for some instruments, this may require a manual override to select the peak detector). If the instrument does not have a band power function, then sum the spectrum levels (in linear power units) at intervals equal to the RBW extending across the DTS channel bandwidth.

PKPM1 Peak power meter method:

The maximum peak conducted output power may be measured using a broadband peak RF power meter. The power meter shall have a video bandwidth that is greater than or equal to the DTS bandwidth and shall use a fast-responding diode detector.

8.3 TEST SETUP

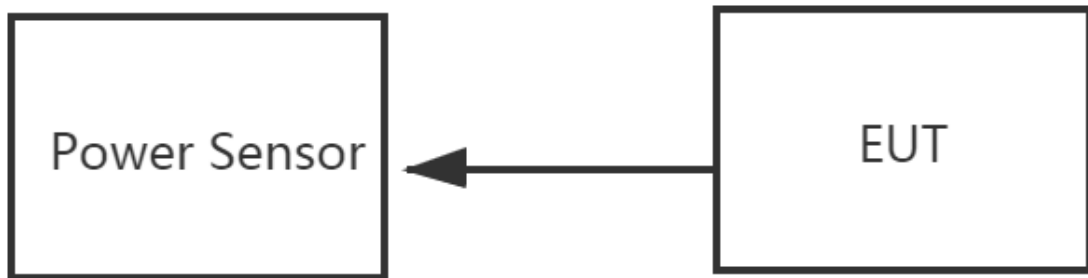

8.4 EUT OPERATION CONDITIONS

Please refer to section 3.4 of this report.





8.5 TEST RESULTS

Temperature:	25 °C	Relative Humidity:	60%
Test Voltage:	AC 120V/60Hz	Test Mode:	TX Mode /CH01, CH21, CH41

Modulation	Frequency (MHz)	Peak Output Power (dBm)	Average Reading Power (dBm)	Duty Cycle Factor (dB)	Final Average Output Power (dBm)	Limit (dBm)	Result
FSK	903	11.89	11.73	0.00	11.73	30	Pass
	915	12.25	12.09	0.00	12.09	30	Pass
	927	11.74	11.57	0.00	11.57	30	Pass

EIRP

Test Channel	Frequency	Peak Conducted Output Power	Antenna Gain	EIRP Power	LIMIT
	(MHz)	(dBm)	(dBi)	(dBm)	dBm
CH1	903	11.89	4.00	15.89	36.02
CH21	915	12.25	4.00	16.25	36.02
CH41	927	11.74	4.00	15.74	36.02



Duty cycle

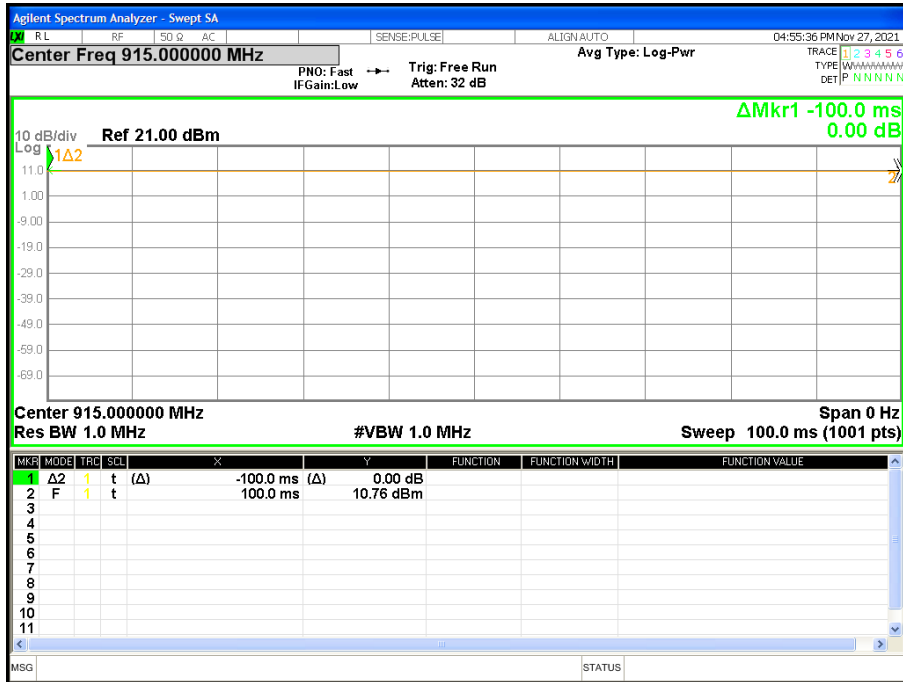

Ton	Tp	Duty cycle(%)	Duty factor(dB)
100.000	100.000	100.00%	0.00

9. ANTENNA REQUIREMENT

9.1 STANDARD REQUIREMENT

15.203 requirement: For intentional device, according to 15.203: an intentional radiator shall be designed to ensure that no antenna other than that furnished by the responsible party shall be used with the device.

9.2 EUT ANTENNA

The EUT antenna is External Antenna. It comply with the standard requirement. The antenna is a non-standard SMA interface antenna, refer to below photo.

Antenna Photo





10. FREQUENCY STABILITY

10.1 LIMITS OF FREQUENCY STABILITY MEASUREMENT

The frequency tolerance of the carrier signal shall be maintained within +/-0.02% of the operating frequency over a temperature variation of -30 degrees to 50 degrees C at normal supply voltage, and for a variation in primary supply voltage from 85% to 115% of the rated supply voltage at a temperature of 20 degrees.

10.2 TEST PROCEDURE

1. The EUT was placed inside the environmental test chamber and powered by nominal DC voltage.
2. Turn the EUT on and couple its output to spectrum analyzer.
3. Turn the EUT off and set the chamber to the highest temperature specified.
4. Allow sufficient time (approximately 30 min) for the temperature of the chamber to stabilize, turn the EUT on and measure the operating frequency after 2,5, and 10 minutes.
5. Repeat step 2 and 3 with the temperature chamber set to the lowest temperature.
6. The test chamber was allowed to stabilize at +20 degree C for a minimum of 30 minutes. The supply voltage was then adjusted on the EUT from 85% to 115% and the frequency record.

10.3 TEST RESULT

Channel 06 (915MHz)

Voltage vs. Frequency Stability

Voltage(V)	Measurement Frequency(MHz)
138	915.0021
120	915.0019
102	915.0014
Max.Deviation(MHz)	0.0021
Max.Deviation(ppm)	2.30

Rated working voltage: AC 120V/60Hz

Temperature vs. Frequency Stability

Temperature(°C)	Measurement Frequency(MHz)
-30	915.0025
-20	915.0016
-10	915.0025
0	915.0016
10	915.0019
20	915.0018
30	915.0024
40	915.0023
50	915.0021
Max.Deviation(MHz)	0.0025
Max.Deviation(ppm)	2.73



11. EUT TEST PHOTO

Note: See test photos in setup photo document for the actual connections between Product and support equipment.

*****END OF THE REPORT*****

