

COOLING BOX COOLFREEZE

FC75/FC95

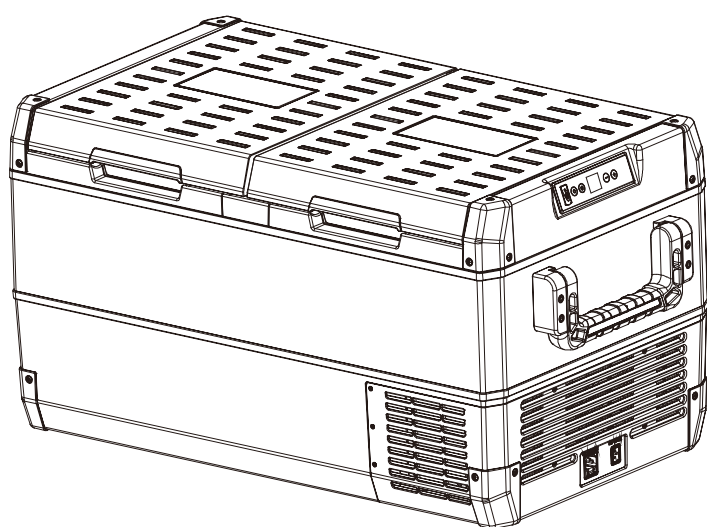

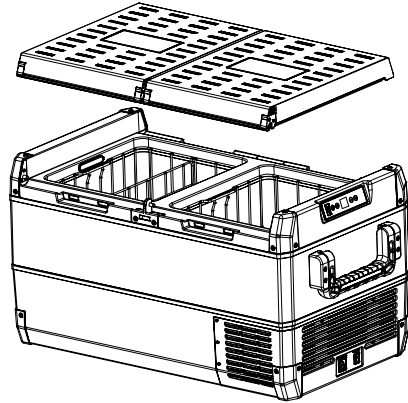
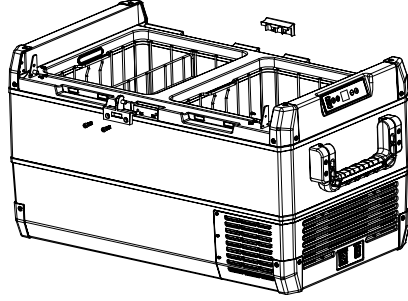
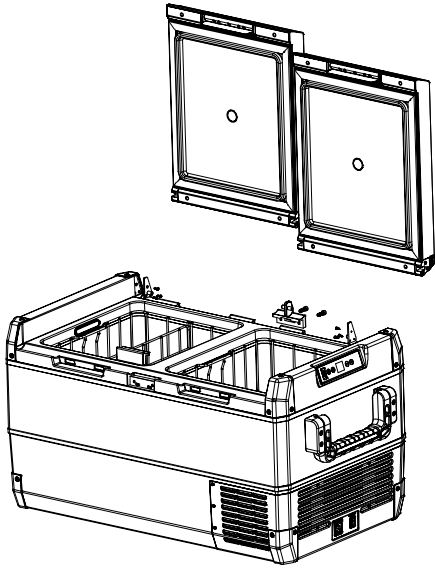

Please read this manual carefully before starting the device. Keep it in a safe place for future reference. If the device is passed on to another person, this manual must be handed over to the user along with it.

The manufacturer cannot be held liable for damage resulting from improper usage or incorrect operation.

Contents

1. Explanation of symbols	01
2. Safety instructions	01
3. Scope of delivery	08
4. Function description	08
4.1 Scope of functions	08
4.2 Operating and display elements	09
5. Operation	12
5.1 Before initial use	12
5.2 Energy saving tips	12
5.3 Connecting the cooler	12
5.4 Using the cooler	13
5.5 Setting the temperature	13
5.6 Battery Protection	14
5.7 Switching a compartment off/on (FC75/FC95)	14
5.8 Downloading Bluetooth App	14
5.9 Setting the Bluetooth signal and connecting to the APP	14
5.10 USB port for power supply	15
5.11 Defrosting the cooler	15
5.12 Replacing DC fuse	15
5.13 Replacing the fuse of the DC plug	16
5.14 Replacing the light PCB	16
6. Cleaning and maintenance	16
7. Troubleshooting	16
8. Guarantee	20
9. Disposal	20
10. Technical data	20

1 Explanation of symbols



DANGER!

Safety instruction: Failure to observe this instruction will cause fatal or serious injury.



CAUTION!

Safety instruction: Failure to observe this instruction can lead to injury.



NOTICE!

Failure to observe this instruction can cause material damage and impair the function of the product.



NOTE!

Supplementary information for operating the product.

2 Safety instructions

General requirements for all instructions CB, LVD:

- GWP: R1234yf:4
- This appliance is not intended for use by persons (including Children) with reduced physical, sensory or mental capabilities, or lack of experience and knowledge, unless they have been given supervision or instruction concerning use of the appliance by a person responsible for their safety.
- Children should be supervised to ensure that they do not play with the appliance.
- This appliance can be used by children aged from 8 years and above and

persons with reduced physical, sensory or mental capabilities or lack of experience and knowledge if they have been given supervision or instruction concerning use of the appliance in a safe way and understand the hazards involved. Children shall not play with the appliance. Cleaning and user maintenance shall not be made by children without supervision.

- Children aged from 3 to 8 years are allowed to load and unload refrigerating appliances.
- It must only be supplied at safety extra low voltage corresponding to the marking on the appliance.
- If the supply cord is damaged, it must be replaced by the manufacturer, its service agent or a similarly qualified person in order to avoid a hazard.
- Suitable for camping use and the appliance shall not be exposed to rain.

CAUTION

- Please keep the products away from the fire or similar glowing substance before you dispose the refrigerator.
- Disconnect the power supply before cleaning and maintenance.
- Do not store explosive substances such as aerosol cans with a flammable propellant in this appliance.
- This appliance is intended to be used in household and similar applications such as
 - staff kitchen areas in shops, offices and other working environments;
 - farm houses and by clients in hotels, motels and other residential type environments;
 - bed and breakfast type environments;
 - catering and similar non-retail applications.

WARNING!

When positioning the appliance, ensure the supply cord is not trapped or damaged.

 **WARNING!**

Do not locate multiple portable socket-outlets or portable power supplies at the rear of the appliance.

GD JG Electronic Ltd

**Building 6, No.58 Gaozeng Street, Renhe Town, Baiyun District,
Gugangzhou, China.**

www.frozen32.com

To avoid contamination of food, please respect the following instructions:

- Opening the door for long periods can cause a significant increase of the temperature in the compartments of the appliance.
- Clean regularly surfaces that can come in contact with food and accessible drainage systems.
- Store raw meat and fish in suitable containers in the refrigerator, so that it is not in contact with or drip onto other food.
- If the refrigerating appliance is left empty for long periods, switch off, defrost, clean, dry, and leave the door open to prevent mould developing within the appliance.

Correct Disposal of this product



- This marking indicates that this product should not be disposed with other household wastes throughout the EU. To prevent possible harm to the environment or human health from uncontrolled waste disposal, recycle it responsibly to promote the sustainable reuse of material resources. To return your used device, please use the return and collection systems or contact the retailer where the product was purchased. They can take this product for environmental safe recycling.

For user manual, add following comment.

- This device complies with Part 15 of the FCC Rules. Operation is subject to the following two conditions: (1) this device may not cause harmful interference, and (2) this device must accept any interference received, including interference that may cause undesired operation.

FCC Caution:

- Changes or modifications not expressly approved by the part responsible for compliance could void the user's authority to operate the equipment.

FCC Statement:

- This equipment has been tested and found to comply with the limits for a Class B digital device, pursuant to part 15 of the FCC Rules. These limits are designed to provide reasonable protection against harmful interference in a residential installation. This equipment generates, uses and can radiate radio frequency energy and, if not installed and used in accordance with the instructions, may cause harmful interference to radio communications. However, there is no guarantee that interference will not occur in a particular installation. If this equipment does cause harmful interference to radio or television reception, which can be determined by turning the equipment off and on, the user is encouraged to try to correct the interference by one or more of the following measures:

- Reorient or relocate the receiving antenna.
- Increase the separation between the equipment and receiver.
- Connect the equipment into an outlet on a circuit different from that to which the receiver is connected.
- Consult the dealer or an experienced radio/TV technician for help."

RSS-Gen & RSS-247 statement:

- This device complies with Industry Canada licence-exempt RSS standard(s).
- Operation is subject to the following two conditions: (1) this device may not cause interference, and (2) this device must accept any interference, including interference that may cause undesired operation of the device.

- Le présent appareil est conforme aux CNR d'Industrie Canada applicables aux appareils radio exempts de licence. L'exploitation est autorisée aux deux conditions suivantes : (1) l'appareil ne doit pas produire de brouillage, et (2) l'utilisateur de l'appareil doit accepter tout brouillage radioélectrique subi, même si le brouillage est susceptible d'en compromettre le fonctionnement.

RF Radiation Exposure Statement Caution: This Transmitter must be installed to provide a separation distance of at least 20 cm from all persons.

Déclaration d'exposition Attention: Cet émetteur doit être installé pour fournir une distance de séparation d'au moins 20 cm de toute personne.



WARNING!

- Do not operate the cooling device if it is visibly damaged.
- If this cooling device's power cable is damaged, it must be replaced by the manufacturer, customer service or a similarly qualified person in order to prevent safety hazards.
- If the power cord of the refrigerator is damaged, it must be replaced to prevent safety hazards
- This cooling device may only be repaired by qualified personnel. Improper repairs can lead to considerable hazards.
- This cooling device can be used by children aged 8 years or over, as well as by persons with diminished physical, sensory or mental capacities or a lack of experience and/or knowledge, providing they are supervised or have been taught how to use the cooling device safely and are aware of the resulting risks.
- Cleaning and user maintenance must not be carried out by children without supervision.
- Children must be supervised to ensure that they do not play with the cooling device.