

Important Safety Instructions

IMPORTANT SAFETY INSTRUCTIONS

READ ALL INSTRUCTIONS BEFORE

USING THIS APPLIANCE

When using an electrical appliance, basic precautions should always be followed, including the following:

WARNING: Read all safety warnings and instructions.

Failure to follow the warnings and instructions may result in electric shock, fire or serious injury.

1. Do not allow to be used as a toy. Close attention is necessary when used by or near children.
2. Clear the area to be cleaned. Remove power cords and small objects from the floor that could entangle the Appliance. Tuck rug fringe under the rug base, and lift items such as curtains and tablecloths off the floor.
3. If there is a drop off in the cleaning area due to a step or stairs, you should operate the Appliance to ensure that it can detect the step without falling over the edge. It may become necessary to place a physical barrier at the edge to keep the unit from falling. Make sure the physical barrier is not a trip hazard.
4. Only use as described in this manual. Only use attachments recommended or sold by the manufacturer.
5. Do not handle plug or appliance with wet hands.
6. Non-rechargeable batteries are prohibited.
7. Do not use without dust bin and/or filters in place.
8. Do not operate the vacuum in an area where there are lit candles or fragile objects on the floor to be cleaned.
9. Do not use and store in extremely hot or cold environments (below -5°C /23°F or above 40°C/104°F). Please charge the robot in temperature above 0°C/32°F and below 40°C/104°F.
10. Keep hair, loose clothing, fingers, and all parts of body away from any openings and moving parts.
11. Do not operate the Appliance in a room where an infant or child is sleeping.
12. For INDOOR use ONLY. Do not use the Appliance in outdoor, commercial or industrial environments. Do not use Appliance on wet surfaces or surfaces with standing water.
13. Do not allow the Appliance to pick up large objects like stones, large pieces of paper or any item that may clog the Appliance.
14. Do not use to pick up flammable or combustible materials such as gasoline, printer or copier toner, or use in areas where they may be present.
15. Do not pick up anything that is burning or smoking, such as cigarettes, matches, hot ashes, or anything that could cause a fire.
16. Do not put any object into openings. Do not use with any opening blocked; keep free of dust, lint, hair, and anything that may reduce air flow.
17. Take care not to damage the power cord. Do not pull on or carry the Appliance or Docking Station by the power cord, use the power cord as a handle, close a door on the power cord, or pull power cord around sharp edges or corners. Do not run Appliance and Docking station over the power cord. Keep power cord away from hot surfaces. Do not unplug by pulling on cord. To unplug, grasp the plug, not the cord.
18. If the power cord is damaged, it must be replaced by the manufacturer or its service agent in order to avoid a hazard.
19. Do not use with a damaged power cord or plug. Do not use the Appliance or Docking Station if it is not working properly, has been dropped, damaged, left outdoors, or come in contact with water. It must be repaired by the manufacturer or its service agent in order to avoid a hazard.

20. Turn OFF the power switch before cleaning or maintaining the Appliance. Turn off all controls before unplugging. Always turn off this appliance before connecting or disconnecting motorized nozzle.
21. Remove the Appliance from the Docking Station, and turn OFF the power switch to the Appliance before removing the battery for disposal of the Appliance.
22. The battery must be removed and discarded according to local laws and regulations before disposal of the Appliance.
23. Please dispose of used batteries according to local laws and regulations.
24. Do not incinerate the Appliance even if it is severely damaged. The batteries can explode in a fire.
25. When not using the Docking Station, unplug from outlet when not in use and before servicing.
26. The Appliance must be used in accordance with the directions in this Instruction Manual. ECOVACS HOME SERVICE ROBOTICS cannot be held liable or responsible for any damages or injuries caused by improper use.
27. Prevent unintentional starting. Ensure the switch is in the off position before connecting to battery pack, picking up or carrying the appliance.
28. When battery pack is not in use, keep it away from other metal objects, like paper clips, coins, keys, nails, screws or other small metal objects, that can make a connection from one terminal to another. Shorting the battery terminals together may cause burns or a fire.
29. Under abusive conditions, liquid may be ejected from the battery; avoid contact. If contact accidentally occurs, flush with water. If liquid contacts eyes, additionally seek medical help. Liquid ejected from the battery may cause irritation or burns.
30. Do not use a battery pack or appliance that is damaged or modified. Damaged or modified batteries may exhibit unpredictable behavior resulting in fire, explosion or risk of injury.
31. Do not expose a battery pack or appliance to fire or excessive temperature. Exposure to fire or temperature above 130°C may cause explosion. The temperature of 130°C can be replaced by the temperature of 265°F.
32. Follow all charging instructions and do not charge the battery pack or appliance outside of the temperature range specified in the instructions. Charging improperly or at temperatures outside of the specified range may damage the battery and increase the risk of fire.
33. Have servicing performed by a qualified repair person using only identical replacement parts. This will ensure that the safety of the product is maintained.
34. Do not modify or attempt to repair the appliance or the battery pack (as applicable) except as indicated in the instructions for use and care.
35. Place the cords from other appliances out of the area to be cleaned.
36. Do not operate the vacuum in a room that has lit candles on furniture that the vacuum may accidentally hit or bump into.
37. Do not allow children to sit on the vacuum.
38. Use only as described in this manual. Use only manufacturer's recommended attachments.
39. Recharge only with the charger specified by the manufacturer. A charger that is suitable for one type of battery pack may create a risk of fire when used with another battery pack.
40. Use appliances only with specifically designated battery packs. Use of any other battery packs may create a risk of injury and fire.
41. The robot contains batteries that are only replaceable by skilled persons. To replace the robot's battery, please contact Customer Service.
42. If the robot will not be used for a long time, fully charge the robot and power OFF for storage and unplug the Docking Station.

43. To Reduce The Risk Of Electric Shock – Do not use on wet surfaces. Do not expose to rain. Store indoors.
44. To Reduce The Risk Of Injury From Moving Parts – Unplug Before Servicing.
45. Risk Of Injury. Brush May Start Unexpectedly. Unplug Before Cleaning or Servicing.
46. To reduce the risk of injury, user must read instruction manual.
47. To Reduce The Risk Of Electric Shock – Do not use outdoors or on wet surfaces.
48. Please make sure your power supply voltage matches the power voltage marked on the Docking Station.
49. Do not use the Docking Station if it is damaged.
50. The plug must be removed from the receptacle before cleaning or maintaining the Docking Station.

≡	Direct current
~	Alternating current

This Device Complies with DHHS Radiation Rules, 21CFR Chapter 1, Subchapter J.

Federal Communications Commission (FCC) Interference Statement

NOTE: This equipment has been tested and found to comply with the limits for a Class B digital device, pursuant to Part 15 of the FCC Rules.

These limits are designed to provide reasonable protection against harmful interference in a residential installation. This equipment generates, uses and can radiate radio frequency energy and, if not installed and used in accordance with the instructions, may cause harmful interference to radio communications.

However, there is no guarantee that interference will not occur in a particular installation. If this equipment does cause harmful interference to radio or television reception, which can be determined by turning the equipment off and on, the user is encouraged to try to correct the interference by one or more of the following measures:

- Reorient or relocate the receiving antenna.
- Increase the separation between the equipment and receiver.
- Connect the equipment into an outlet on a circuit different from that to which the receiver is connected.
- Consult the dealer or an experienced radio/TV technician for help.

This device complies with Part 15 of the FCC Rules.

Operation is subject to the following two conditions:
(1) This device may not cause harmful interference, and
(2) this device must accept any interference received, including interference that may cause undesired operation.

Caution: Changes or modifications to this unit not expressly approved by the party responsible for compliance could void the user's authority to operate the equipment.

This device contains licence-exempt transmitter(s)/ receiver(s) that comply with Innovation, Science and Economic Development Canada's licence-exempt RSS(s).

Operation is subject to the following two conditions:
(1) This device may not cause interference.
(2) This device must accept any interference, including interference that may cause undesired operation of the device.

RF exposure warning

This equipment complies with FCC radiation exposure limits set forth for an uncontrolled environment.
This equipment must be installed and operated in accordance with provided instructions and the antenna(s) used for this transmitter must be installed to provide a separation distance of at least 20 cm from all persons and must not be collocated or operating in conjunction with any other antenna or transmitter.
MPE caution (for mobile device under Part 15.247 & 15.407 device)
To satisfy FCC&ICRF exposure requirements, a separation distance of 20cm or more should be maintained between the antenna of this device and persons during device operation.
To ensure compliance, operations at closer than this distance is not recommended.

Turn on Wifi, When the robot is in power-on condition, press the charging key and partial clean key together for 3-5 seconds, and go to net setting mode (voice remind available)

Turn off Wifi, When the robot is in power-on condition but not in charging, reset it by pressing charging key for 10 seconds (voice remind available)

SAVE THESE INSTRUCTIONS GROUNDING INSTRUCTIONS

For INDOOR household use ONLY.

This device contains licence-exempt transmitter(s)/ receiver(s) that comply with Innovation, Science and Economic Development Canada's licence-exempt RSS(s).

Operation is subject to the following two conditions:

(1) This device may not cause interference.
(2) This device must accept any interference, including interference that may cause undesired operation of the device.

To satisfy FCC&ICRF exposure requirements, a separation distance of 20cm or more should be maintained between the antenna of this device and persons during device operation.
To ensure compliance, operations at closer than this distance is not recommended.

Device Update

Typically, some devices are updated bi-monthly, but not always so specific.
Some devices, especially those that went on sale more than three years ago, will only be updated if a critical vulnerability is found and fixed.

1. PACKAGE CONTENTS

1.1 Package content

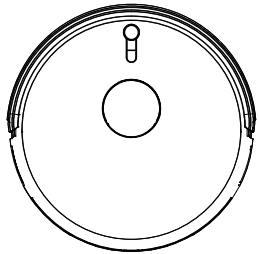

Robot

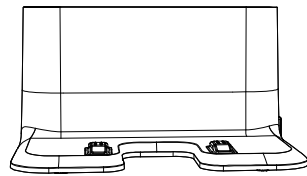

Charger

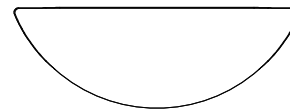

Washable mop

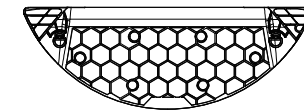

Mop frame

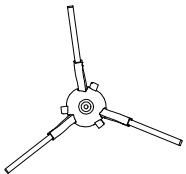

Side brush



Adapter

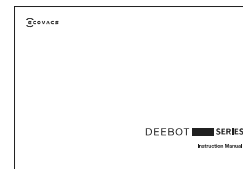

Instruction Manual



Screw bag

* The diagram in this user manual is for reference only, the real appearance refers to product.
For details, please visit <http://mall.ecovacs.cn>.

1.2 PRODUCT DIAGRAM

Robot

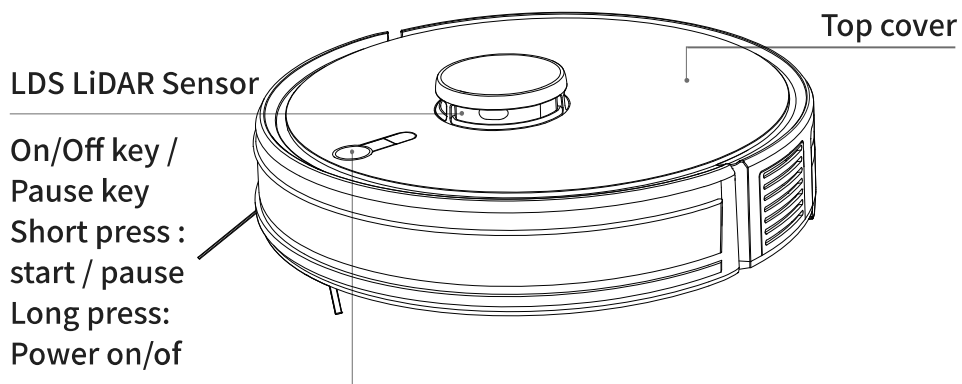

Charging key:
Long press: connect wifi
Short press: go to charge

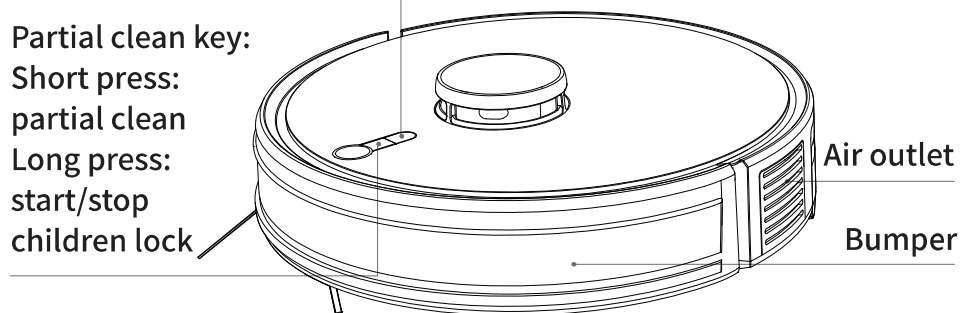

* In the children lock mode, to avoid children operation, keys and intelligent voice box can not work normally.

2 in 1 water tank and dust box

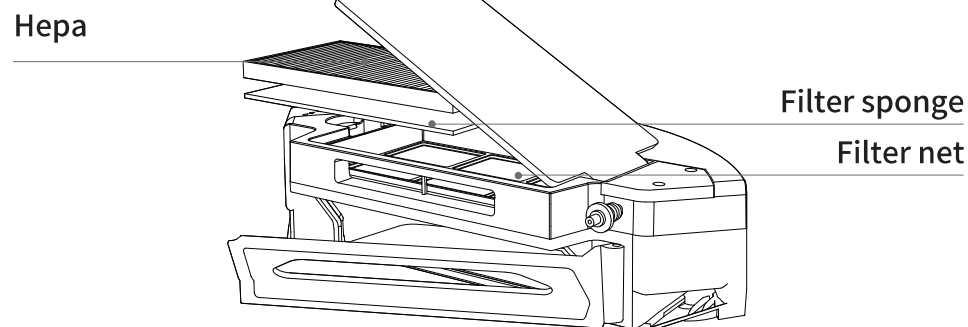
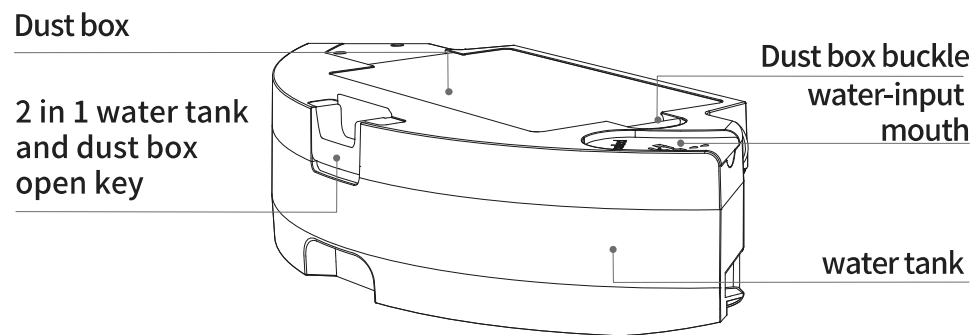

Mop unit

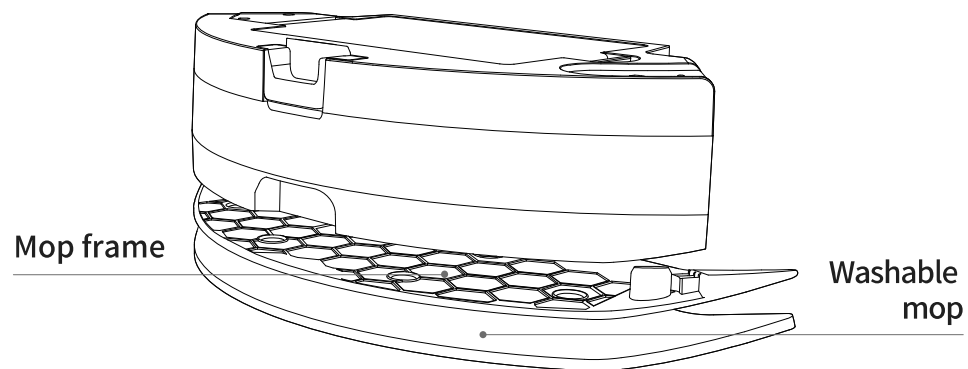

Bottom View

Down visual sensor

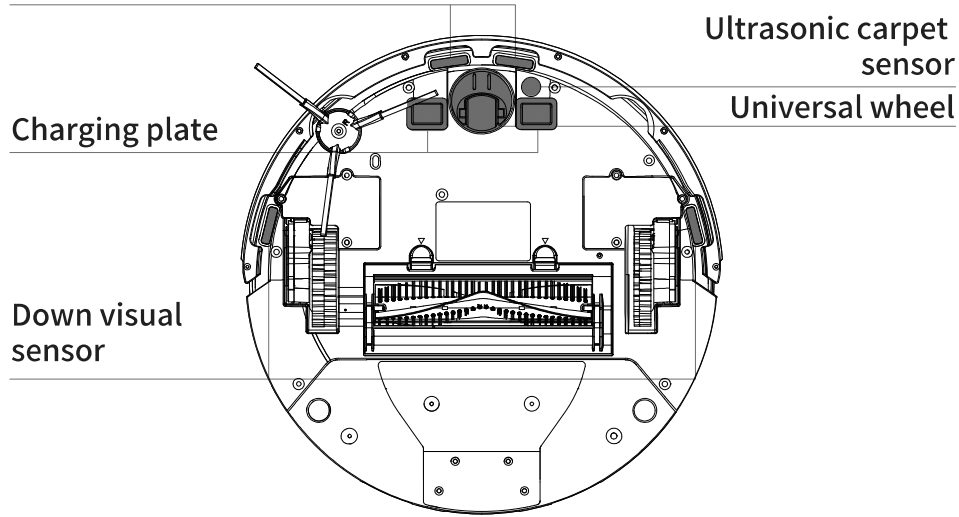

Roller brush open-key

Driving wheel

Mop unit open-hole

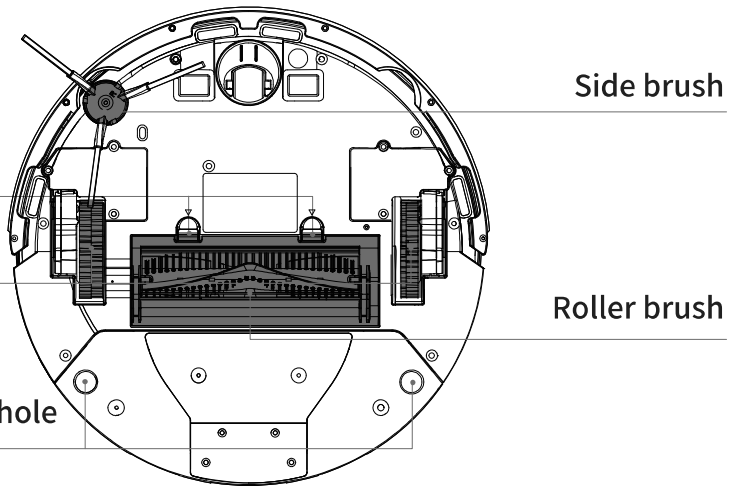

Charging Stand

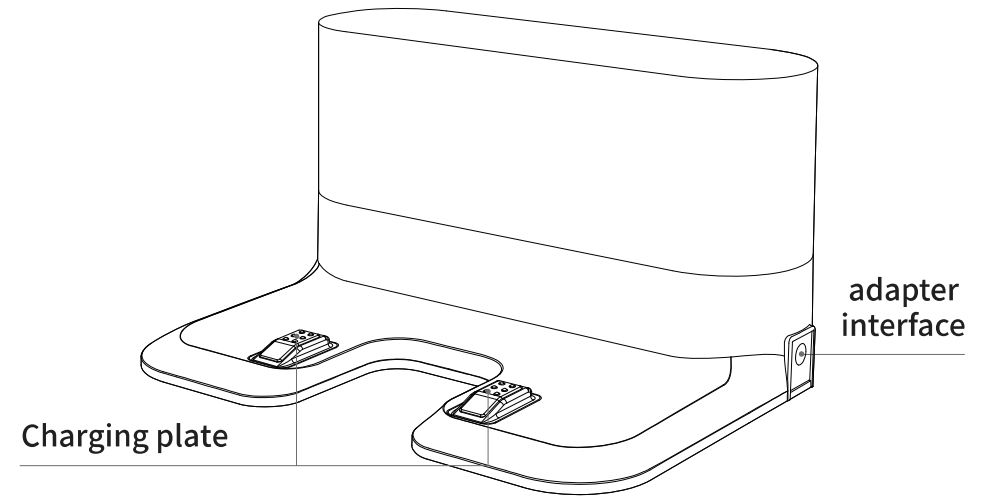

1.3 Sensor Instruction

Name	Function Description
LDS LiDAR Sensor	Make use of the laser ranging principle, by calculating the time between transmitting and receiving the reflected lighting, by the algorithm to calculate the distance between the robot cleaner and objects, and by positioning the objects around, the robot cleaner creat a map when it moves around. The measuring range of 10 m.
Down visual sensor	Make use of infrared ranging principle, the down visual sensor in the bottom of the machine detects the distance between machine bottom and surface. If there is stair ahead(eg. 90mm lower than surface), the sensor recognizes it is beyond setting, the machine does not move forward, so it avoid the machine to drop down.
Ultrasonic carpet sensor	The sensor launches 300KHz ultrasonic wave, the ultrasonic wave energy is absorbed by carpet when it exists. When the returned energy is less than launched previously, the machine recognize the existance of carpet. It can recognize more than 50 kinds of carpet in Ecovacs laboratory .

2. Product Usage

2.1 Attention

Tidy the room before cleaning

Before cleaning, please put the table chair etc. Furniture in place, and take away wight scale etc. low objects, and get room as big as possible.

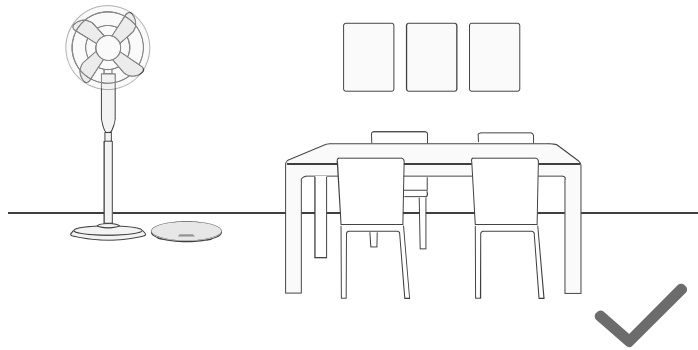

Open every doors to allow machine to explore

To allow machine to create a full and detailed map, please open all room doors when it works for the first time.

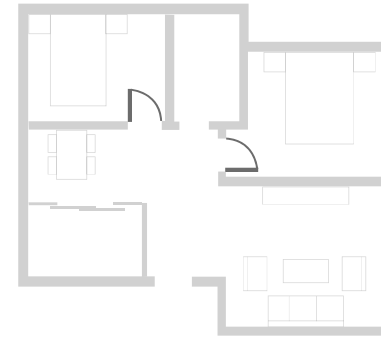

Prevent machine to drop down

When the machine works near stairs, steps etc., please place protective fence to ensure its safety.

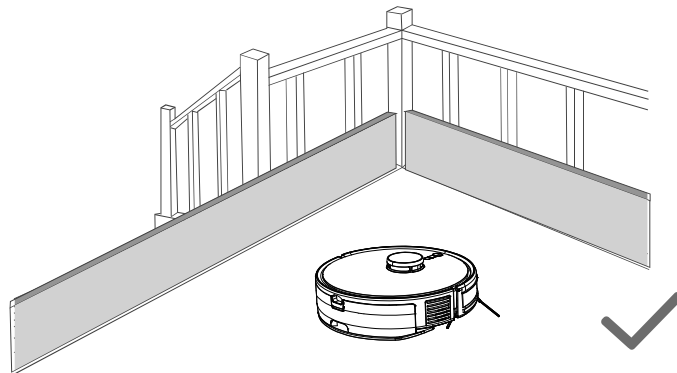

Take away the power cord, mop, slipper etc. Objects to improve the machine working efficiency.



If there is lace on the carpet, please fold the edge under the carpet. Please do not use mop function on the carpet.



To allow machine to recognize the cleaning area, please don't stand in front of the machine, in the gate, or at the aisle.

2.2 Preparation

* Before using the product, please remove the protective strip and protective film on the Robot and charging base

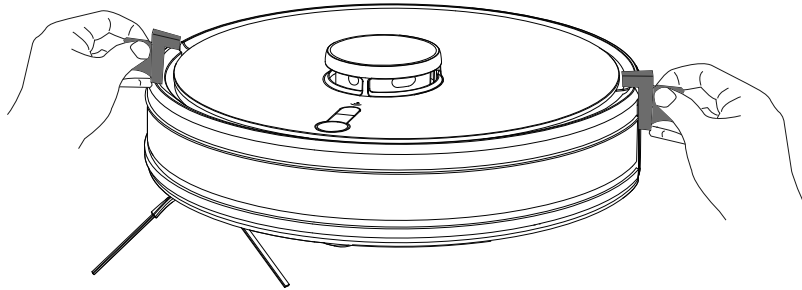

* Before using the product, please remove the screwdriver and screws from the screw pack for installation.

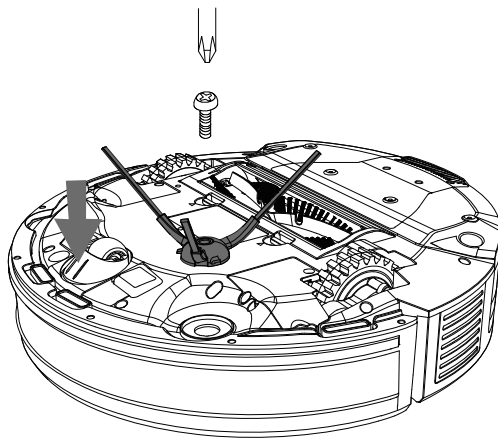

2.3 APP download

Download ECOVACS HOME App, experience more:

Method 1: Scan the code on the machine or user manual, free download and install the App according to indication.

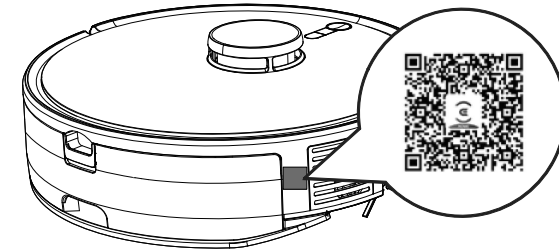

Method 2: Open the store setting in cellphone, explore “ECOVACS HOME”, download and install.

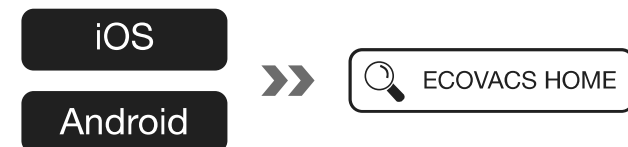

Kind attention:

- After installation, please follow App to finish registration, log-in, and net connection.

Before WI-FI setting, please ensure the robot cleaner, cellphone, and WI-FI comply to following requirement.

- The robot cleaner should be full charged and powered on.
- WI-FI indicator brights all the time.
- Close the mobile network (open it when setting completed).

WI-FI requirement

- Use 2.4G Hz or 2.4/5G Hz network.
- Router supports 802.11b/g/n and IPv4 protocol.
- Don't use VPN or proxy server.
- Don't use hidden network.
- Use TKIP, PSK, AES/CCMP and encrypted WPA and WPA2.
- Don't support WEP EAP.
- Use WI-FI channel 1-11 in north America, use WI-FI channel 1-13 out of north America.(Please ask local regulator.
- If use net expander or repeater, their net name(SSID) and password are same as the ones of main net.

Please be noted, all the intelligent functions, including remote controlled switch on, voice interaction, 2D/3D map display, operation setting, personalized clean mode etc., should be achieved by downloading and updating ECOVACS HOME App. You need to agree our "private policy" and "user agreement", then we can handle your basic and necessary information and satisfy you to operate the robot machine by ECOVACS HOME App. If you don't agree our "private police" and "user agreement", you can't operate the intelligent function mentioned above in ECOVACS HOME App, but you can use the manually operated basic function.

2.4 Robot charging

- 1 Connecting the power line.

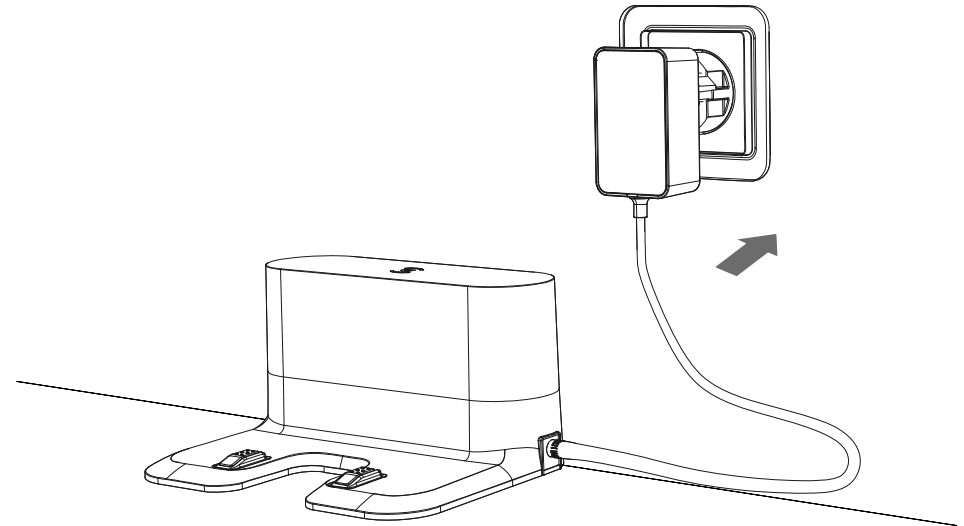

2 Put the Charger in proper position

Put the charger on even ground beside the wall. Keep the surrounding (0.05m left and right each side, 0.8m front side) empty.

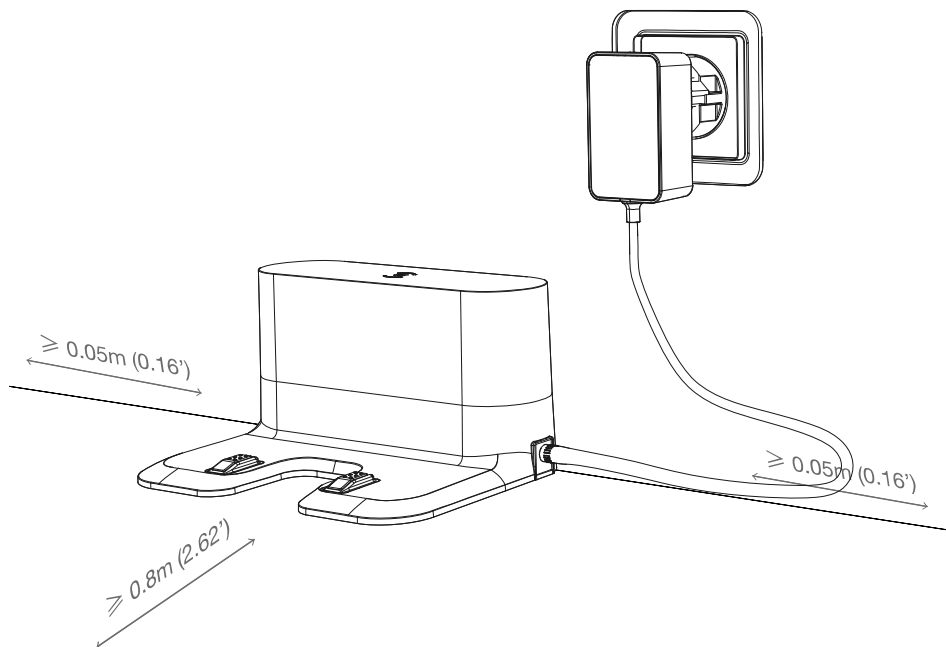

3 Switch on the robot cleaner

Press and hold the On/Off key 3 seconds to start the robot cleaner.

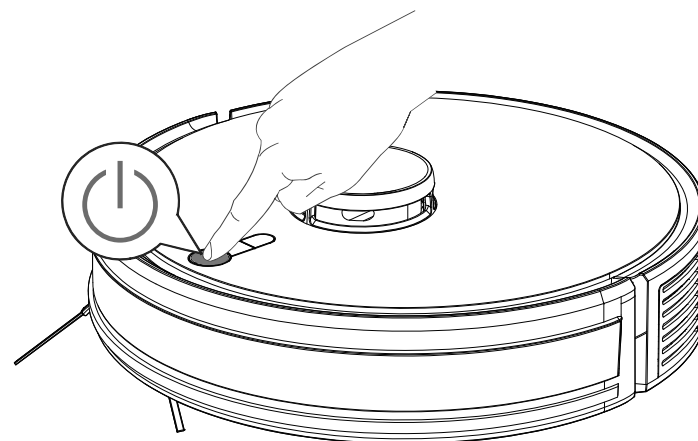

- * If there is mirror or reflecting object, please cover 14cm height from the bottom.
- * Please don't put the charger in sunshine.
- * It is recommended to put the charger on solid ground.

4 Charging

Shot the robot cleaner charging key, it will go back to charge.

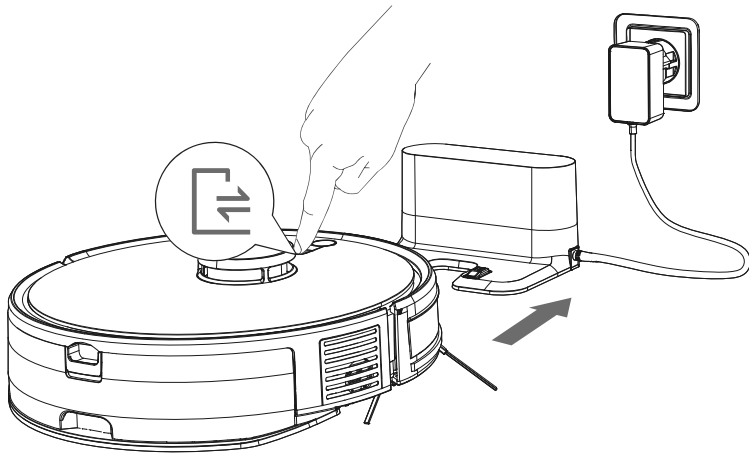

* When the charging stand is installed, the robot cleaner will go to charge and release dirt if necessary. To allow the robot cleaner go to charge when it finishes the charging, it is recommended that the robot cleaner starts from the charging stand, and not move the charging stand when robot cleaner in working.

2.5 Start Clean

1 Create map

Make use of the fast map creation function in ECOVACS HOME APP, the machine will explore the home surroundings and create map promptly. Or short press the  key to start work and create map at the same time. Please follow the robot cleaner to clean unfriendly objects when it creates the map at first time.

Eg. The robot cleaner may be blocked in low place of the furniture. Solve the issue as below.

- ① Lift up the furniture if possible
- ② Cover the bottom of the furniture, prevent the robot cleaner to move into
- ③ Set virtual wall in App, prevent the robot cleaner to move into

2 Start Clean

If it starts to work at the first time, please ensure it is on the charging stand and fully charged. Short press the  key, it will start to clean and create map.

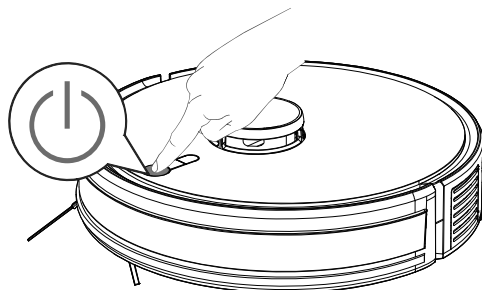

3 Pause

When it is in working, short press its  key to pause.

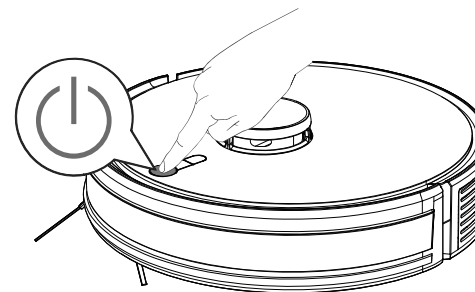

4 Wake up

When it stops for some time, all the indicators on the cover are off. If restart it, please short press the  key.

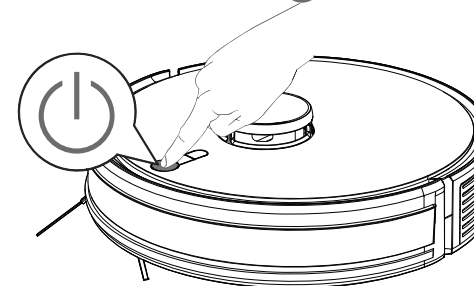

5 Partial Clean

Short press  key, it will clean the area 1.5*1.5m with its position as center.

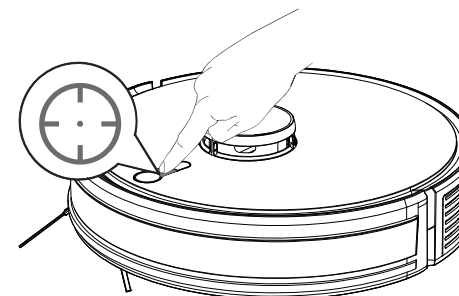

7 Go to Charge

Short press  key, robot goes to charge.

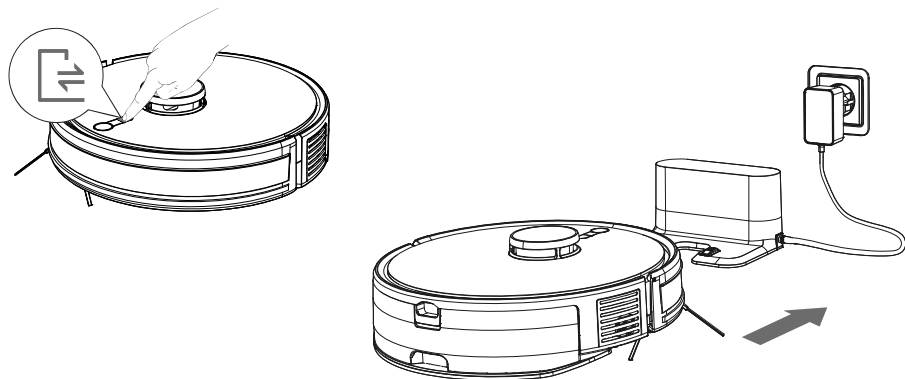

* It is recommended to stay the robot in charging after it finishes work, so that it keeps good condition in work next time.

2.6 Start Mopping

1 Input Water

Take out the water tank and dust box unit, open the water input mouth and put in water.

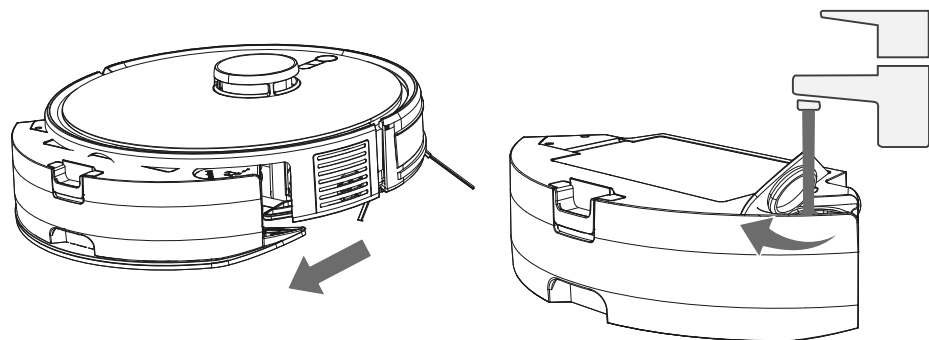

2 Install mop and mop frame

Stick the white side of the mop onto the velcro of the mop frame. Insert the protruded part of the mop frame into the mouth of the mop unit.

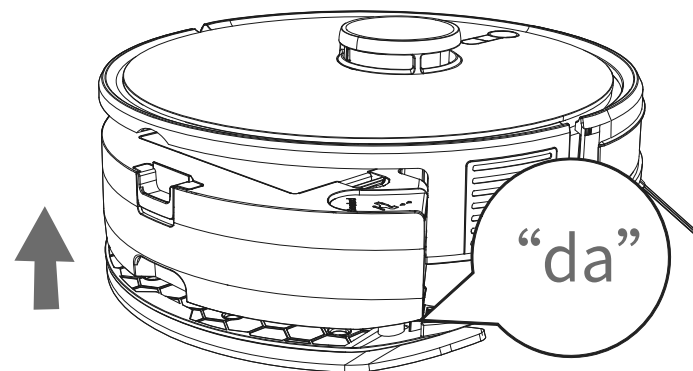

3 Start Mopping

Short press  key, the robot cleaner starts mopping.

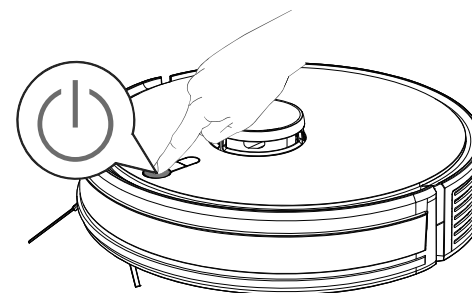

Warming note:

- 1) It is possible to choose clean and mop mode or mop mode in APP.
- 2) To extend the lifespan of washable mop, don't take it off frequently.
- 3) To keep the lifespan of velcro, don't scratch the mop frame with mop or any other thing.

When the ECOVACS HOME App reminds to replace the mop, please replace it immediately. If you want to buy accessories, please visit ECOVACS HOME App store or <https://www.ecovacs.com/global>.

3.Part maintenance

3.1 Maintenance frequency

To make the machine in good condition, please maintain parts according to following recommendation:

Part	Maintenance frequency	Replacement frequency
Washable mop	/	every 1-2 months
Side brush	every 2 weeks	every 3-6 months
Roller brush	every week	every 6-12 months
Filter element	every week	every 3-6 months
TTrueMapping laser module Universal wheel Down vision sensor Bumper Robot cleaner charging plate Charging plate	every week	/

Warm note: If you want to buy accessories, please visit ECOVACS HOME App store or <https://www.ecovacs.com/global>.

3.2 Dust Box

- 1 Take out the dust box, open its cover, release rubbish.

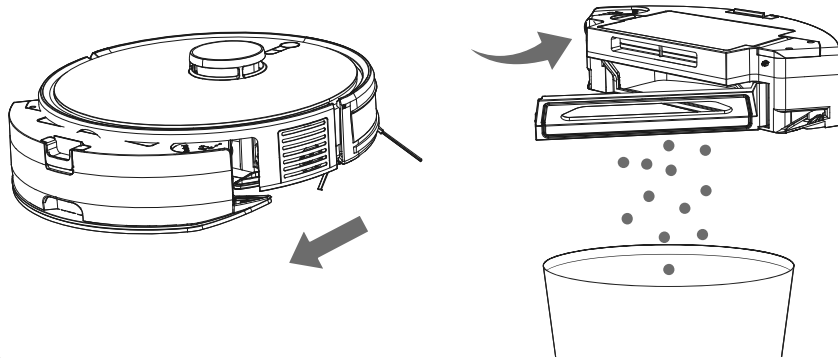

- 2 Open the filter net, take out the filter element.

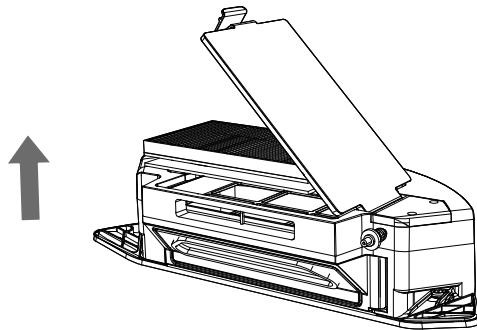

- 3 Clean the dirt on both sides of the filter net.

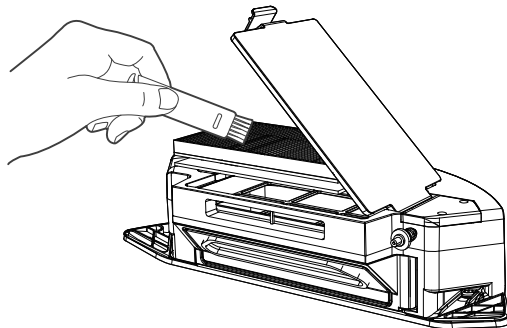

- 4 Wash the dust box and filter element, and spin dry it.

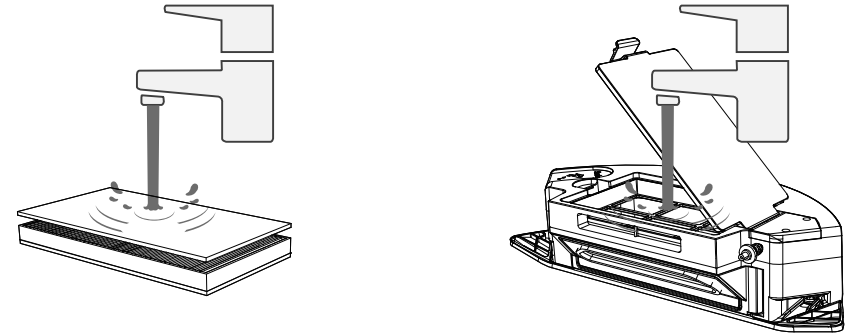

Attention:

Don't wash the filter element with brush or by hand.

- 5 Dry

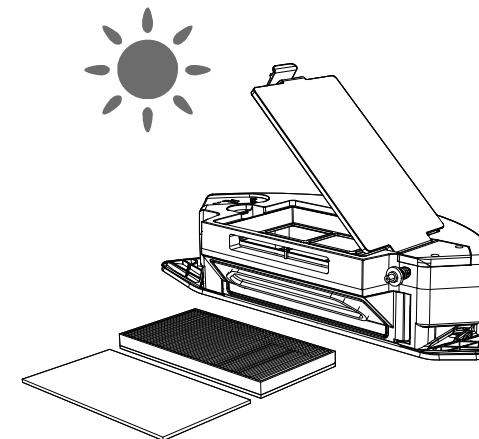

Warm note: Please dry the filter element completely before using. If you want to buy the filter element, please visit ECOVACS HOME App store or <https://www.ecovacs.com/global>.

3.3 Roller brush and side brush

Clean the roller brush

- 1 Open the roller brush cover

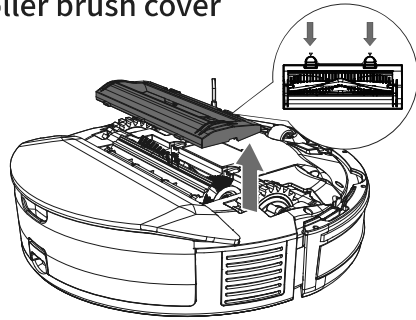

- 2 Take out the roller brush

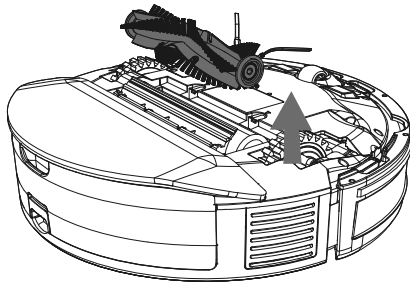

- 3 Clean the roller brush

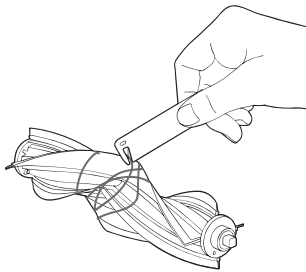

Clean the side brush

- 1 Take off the side brush

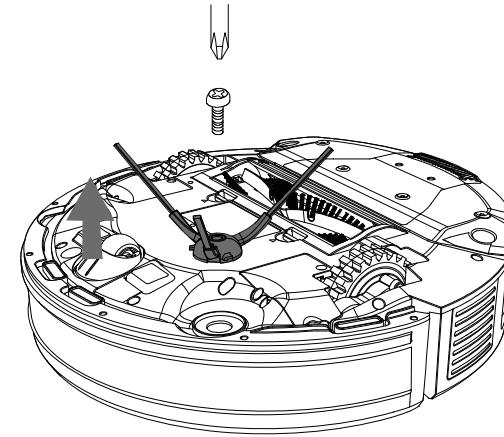

- 2 Clean the side brush

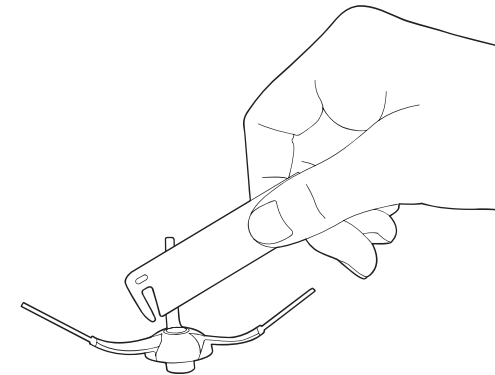

3.4 Other Parts

Clean the bumper

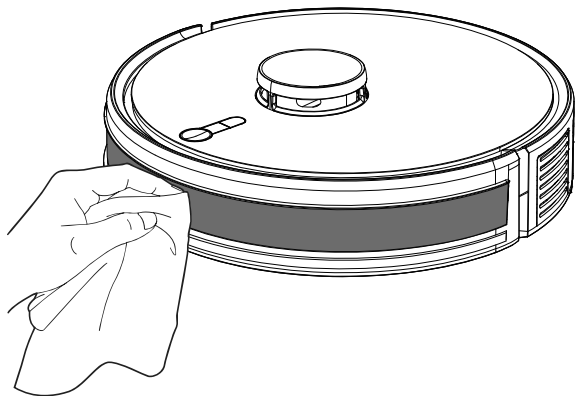

Clean the TrueMapping laser module

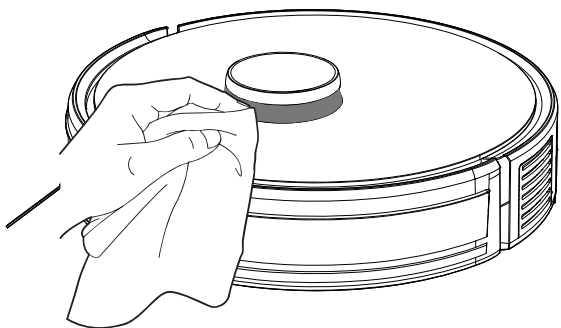

Warm note: Please clean with soft cloth. Please don't clean with wet mop. To be not damaged by water penetration, don't use detergent or sprayer.

Clean down vision sensor

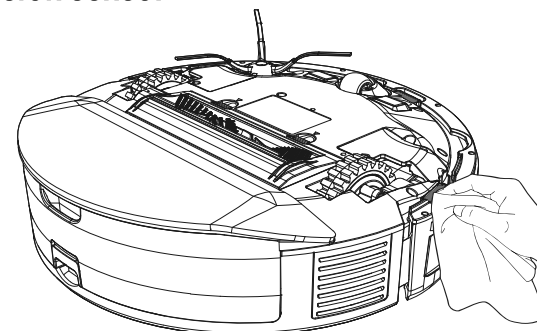

Clean charging plate

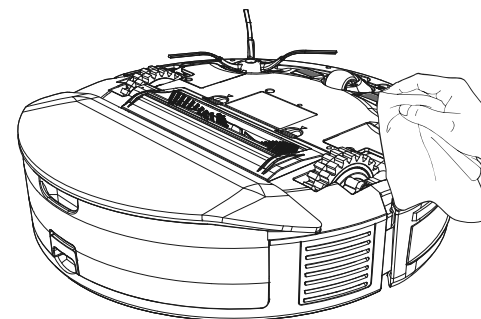

Clean driving wheel and universal wheel

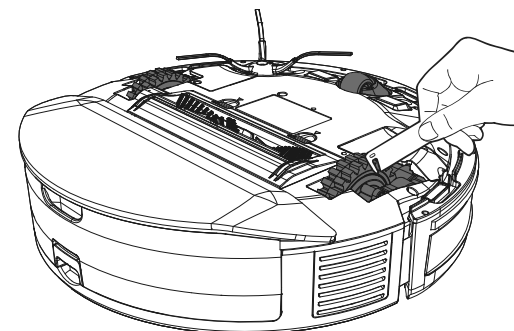

Warm note: There are sensitive electronic parts in the charging plate, please clean it with dry cloth. To be not damaged by water penetration, please don't clean with wet mop.

3.5 Power off and Store

Press and hold the On/Off key for 5 seconds, power off the robot cleaner.

If don' t use the machine for long time, please fully charge it, then power it off. To avoid battery over discharged, please charge it every 1.5 months.

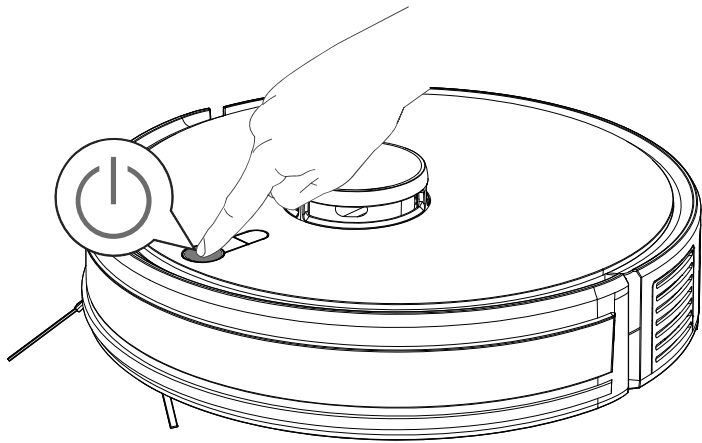

! Please be noted, the robot cleaner can' t be charged in power-off condition.

* It is recommended to not power off when it finishes the work. To allow it work well next time, keep it in charging station.

Battery over discharge or batter does not work for long time, the machine may not charge. Please contact after-sales service to maintain, and don' t disassemble by yourself.

4. Troubleshooting

If have the following issues in using the product, the user can follow the instruction below, and solve them independently.

No.	Malfunction	Possible Causes	Solutions
1	Robot can't connect to APP.	The router user name and password are incorrect.	Configure the router network and make sure that the "user name" and "password" of the router are correct.
		The robot is not within the network signal coverage of the router.	Ensure the robot is within the network signal coverage of the router.
		The robot is not in a pending configuration state.	Network configuration can only be performed on a host when it is in a pending configuration state. The host is powered on, Simultaneously press and hold the recharge button and local cleaning button on the host panel for 3 seconds, and hear the voice "heavy" After setting up WiFi and entering network distribution mode, release it and the WiFi indicator light will flash, indicating the host Enter the pending configuration state.
		Not use 2.4GHz or 2.4/5GHz network.	The robot doesn't support 5G network at present. Please choose 2.4GHz or 2.4/5GHz.
		Download the wrong APP.	Please scan the code or download the ECOVACS HOME App in store.
2	Map lost.	It is possible to lose the map if move the robot manually.	Try to recover by moving the robot into charging stand. Find the stored map in APP map storage, and press " use map" to recover. If it doesn't work in the 2 ways above, please recreat map.

No.	Malfunction	Possible Causes	Solutions
3	Can't creat map in APP.	The robot doesn't work from the the charging stand.	The robot must start clean from charging stand.
		Move the robot when it is in working which causes it is failed in positioning.	Don't move the robot when it is in working.
		The clean work doesn't finish.	Allow the robot return to charging stand when it finishes the clean.
4	Unable to return to Charger.	The position of charger is incorrect.	Please place the charger correctly according to the chapter[robot charge] in user mannual.
		The charger is powered off or moved by people.	Please ensure the charger is powered on, and don't move charger.
		The robot doesn't work from the the charger.	It is recommended the robot starts to work from charger.
		The road of return to charge is blocked, eg. the room door is closed where the charger is placed.	Please ensure the road is unblocked.
5	It returns to charge when the clean is not finished.	The room is too big, and the robot needs to charge before clean finished.	activate the breakpoint resume function. Please refere APP instruction to activate it.
		Complex furniture environ-ment will reduce cleaning efficiency, so it may not finish cleaning.	Tidy the room.

No.	Malfunction	Possible Causes	Solutions
6	Robor can't charge	The charger doesn't connect to electricity .	Ensure the charger is well connected to electricity.
		The robot charging plate and charger charging plate don't touch fully.	Ensure robot charging plate and charger charging plate touch fully. ⏻ key is flashing. Check if robot charging plate and charger charging plate are dirty, refer 【part maintenance】 to clean.
		Battery temperature over high or over low.	Please charge and operate the robot in the temperature 0-40 degree.
		Battery over discharged because long time not used.	Please use the product often. If it can not charge because long time not used, please contact after-sales service.
7	Abnormal noise during cleaning	The roller brush, side brush or driving wheel may be entangled, and the universal wheel may be entangled during the cleaning.	Please clean it after power off. It is recommended to take them out and clean. Refer to regular maintenance.
		The robot is in deep clean mode.	Change to standard clean mode .
8	The robot is in trouble when working	The robot is entangled or obstructed by scattered wires, drooping curtain cloth or carpet tassels on the ground.	The robot will try all kinds of ways to get rid of the trouble, if not, it is recommend-ed to help it manually.
		The main engine may be jammed by furniture of similar height to the robot.	The robot will try all kinds of ways to get rid of the trouble, if not, it is recommend-ed to help it manually.

No.	Malfunction	Possible Causes	Solutions
9	When the robot is working, there are some problems, such as route disorder, deviation, repeated cleaning and small area not cleaned.	The wires, slippers and other objects placed on the ground affect the normal work of the Robot.	Before the robot works, please tidy up the scattered wires, slippers and other objects on the ground, and reduce the scattered objects on the ground as much as possible. If there is uncleaned area, the robot will clean the area independently. Please do not interfere (such as moving the robot or blocking its route)
		When the robot climbs the steps, threshold and door strip, the driving wheel slipped with the ground, which will affect the judgment on the environment of the whole house.	It is recommended to close the door of the area and clean the area separately. After cleaning, it will return to the starting point. Please rest assured to use it
		Working on a newly waxed, polished floor or smooth tile reduces the friction between the driving wheel and the ground.	It is recommended that you wait for the floor wax to dry before using.
		Due to the different house environment, the robot can not enter some areas.	It is suggested to tidy up the home environment to ensure that the Robot can enter for cleaning.
		The TrueMapping laser module is dirty or covered.	Clean the TrueMapping laser module or uncover the objects on it.
10	The robot is dust leaked during working.	The mouth of dust box is blocked.	Take out the dust box unit, and clean the dust box mouth.
11	The water tank and dust box unit drops out of place during use.	The water tank and dust box unit is not correctly installed.	Make sure water tank and dust box unit clicks into place when installing.

No.	Malfunction	Possible Causes	Solutions
12	Driving wheel alarms .	The driving wheel is entangled with something and stuck.	Turn off the robot and put the bottom up; first turn the wheel counterclockwise and then clockwise to turn out the debris and garbage stuck in it; then press and slide the driving wheels on both sides at the same time to check whether it can rotate and whether it can rebound after releasing.
13	Not cleaning as scheduled.	Scheduled appointment cancelled .	Reset appointment.
		Low power.	Charge the robot.
		Robot is in Do Not Disturb mode.	It will not follow scheduled cleaning in Do Not Disturb (DND) mode.
14	Not breakpoint resume cleaning.	The robot is in Do Not Disturb mode.	It will not follow breakpoint resume cleaning in Do Not Disturb mode.
		The robot didn' t automatically return to the charger last time.	Recharging or putting the robot to charger manually, the robot will not follow breakpoint resume cleaning.

If can't solve the issues by following the above instruction, please contact after-sales service people.

5. Product specification

Item no.	DLX34
Rated input	20V === 1.2A
Charge time	About 5.5h
Adapter no.	KA24D-2001200US
Rated input	100-240V ~ 50-60Hz 0.65A Max
Rated output	20V=== 1200mA
Charger no.	CH2331

Output power of the Wi-Fi module is less than 100mW

Note: Technical and design specifications may be changed for continuous product improvement

Explore more accessories at <https://www.ecovacs.com/global>.