

KQi2



CONTENTS

| | |
|------------------------------|----|
| Riding Safety | 01 |
| Packing list | 03 |
| Parts Info | 04 |
| Dashboard Display Info | 05 |
| Installation Guide | 06 |
| Downloading the APP | 12 |
| ARE YOU READY | 14 |
| Warnings | 16 |
| Troubleshooting | 22 |
| Maintenance and Care | 24 |
| Specifications | 29 |

Riding Safety

Please read this manual carefully to better understand the product before riding. Please read the important safety precautions in this manual carefully and always abide by local laws and regulations when riding.

IMPORTANT! Read carefully and keep for future reference.

- Please read the product manual carefully, and ride carefully before you understand the characteristics of the kick scooter.
- This kick scooter is a transportation and recreational tool. When riding in a public area, this scooter may be treated as a vehicle, and there are potential safety risks with all vehicles. Please use this product according to the instructions and warnings in this Manual to maximize the safety of you and others, and comply with national and local laws and regulations.
- Even if you fully comply with this safe driving guide, you may face risks caused by illegal driving or improper operation from other vehicles and individuals. Like all vehicles, the faster you drive a kick scooter, the longer the distance required to brake, it is recommended to ride in a relatively closed and flat road environment (such as inside a community, park, special closed venue , etc.). Therefore, it is important to be vigilant and maintain the proper speed during driving, as well as to maintain a reasonable safety distance from others and vehicles. Please be aware of your surroundings and ride at low speed when on unfamiliar terrain.
- Please respect the pedestrians' right of way when driving. Avoid scaring pedestrians, especially children. Alert pedestrians when passing behind them and slow down when passing. Pass from the left side of pedestrians if possible (applicable to the country where the vehicle is traveling right). When facing pedestrians, keep to the right and slow down to pass.
- When riding in countries and regions where there is currently no relevant regulations for kick scooters, you must strictly comply with the safety requirements for riders in this Manual. The manufacturer will not bear any direct and joint liability for any property loss, personal injury, accidents or legal disputes caused by the using behavior violating safety tips in this Manual.
- Take the time to learn the basics of the practice to avoid any serious accident that can take place in the first months.

- Do not lend the kick scooter to a person who can't operate, so as to avoid injury. Please make sure that the rider has read this Manual and learned the novice teaching before lending the kick scooter to others, and remind riders to wear a helmet and protectors to ensure their safety.
- Check the basic condition of the kick scooter before each ride. Discontinue use and don't ride forcibly if you find such situations influencing driving safety that parts are loose, the parts are damaged, the battery life significantly decreases, the tires are flat or excessively worn and the scooter has abnormal noises or alarms.
- Please properly keep your product packaging in case you need to return or repair in the future. If you use non-original packaging, you will be responsible for the damage caused during transportation, additional logistics costs and other related expenses .

Packing list

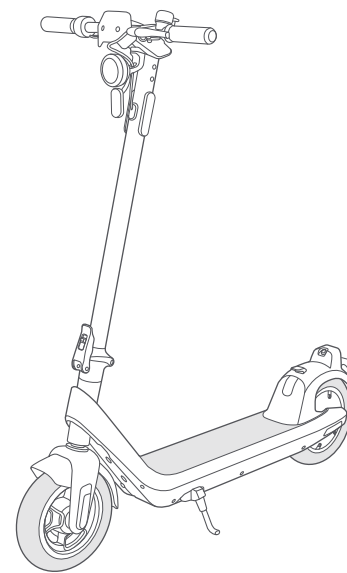

Extension nozzle

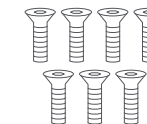

M5 screw × 7
*1 spare



Power adapter



3mm socket head
wrench

Parts Info

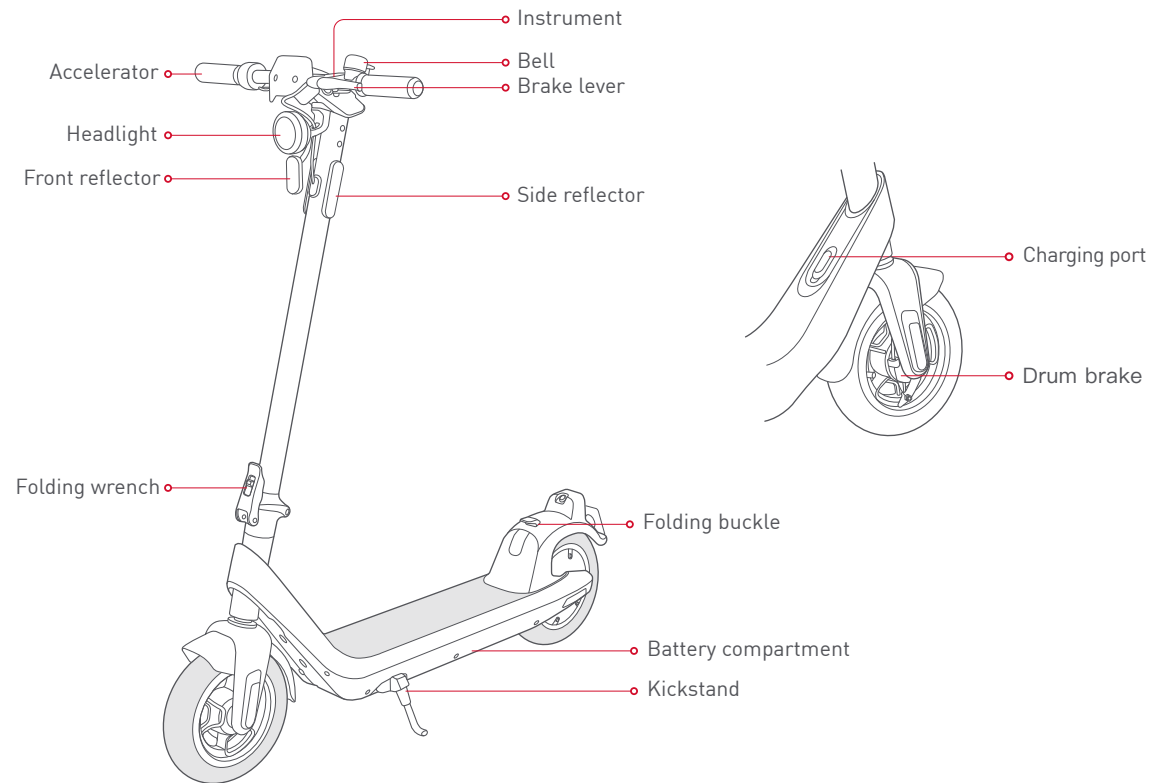

Dashboard Info

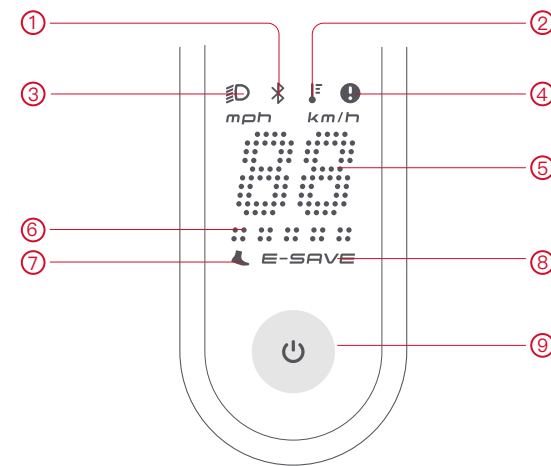

① Bluetooth status

② Abnormal temperature warning

③ Light status

④ Fault warning

⑤ Real-time vehicle speed/fault code display

⑥ Battery indicator

⑦ Pedestrian mode status

Short press *5 to get into the pedestrian mode, the speed will be limited to 6KM/H, Short press the button to exit this mode

⑧ Riding mode

E-SAVE lights up: Eco mode
E-SAVE goes out: Sport mode
E-SAVE flashes: Custom mode (in-appl.)

⑨ Operation keys

Long press the power button to turn on or off the device
Short press *1 for gear switch
Short press *2 for light switch.
Short press *3 for speed unit switch
Short press *5 to get into the pedestrian mode

Installation Guide

Body assembly

01 Secure the scooter neck tube and open the kickstand.

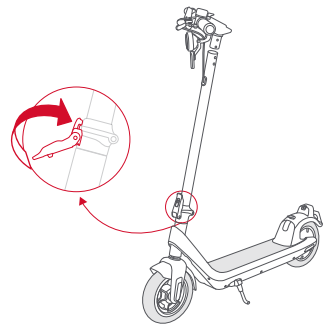

02 Connect the handlebar to the main line connector of the vertical tube, and install the handlebar to the vertical tube.

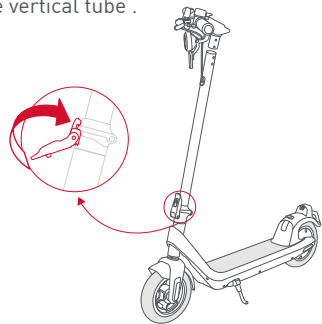

03 Confirm that the device will power on and off after assembly.

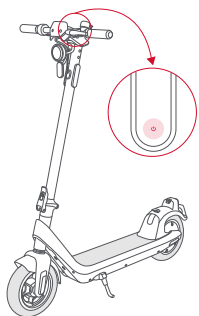

04 Lock the screws on both sides alternately with the hexagon wrench in the packaging box (tightening torque: 4~5N*m), that is, the assembly is completed.

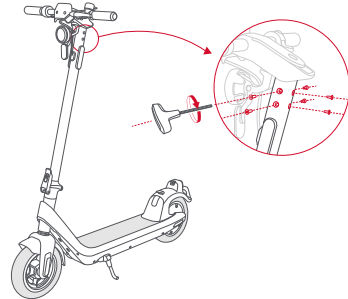

Folding and handling

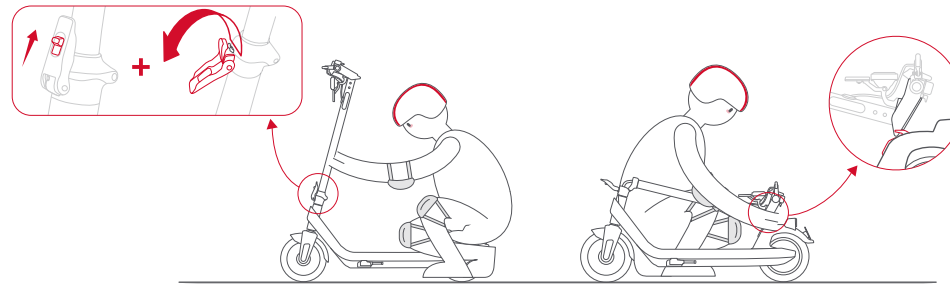

Folding

Confirm that the kick scooter is powered off, then hold the vertical tube, open the folding wrench, align it to the position of the mudguard hook, and finally hook the hook under the dashboard to the rear end of the body. Press the buckle button on the mudguard when opening. After the hook under the dashboard is separated from the folding buckle, straighten the vertical tube to lock the folded plate and then turn the folding wrench back.

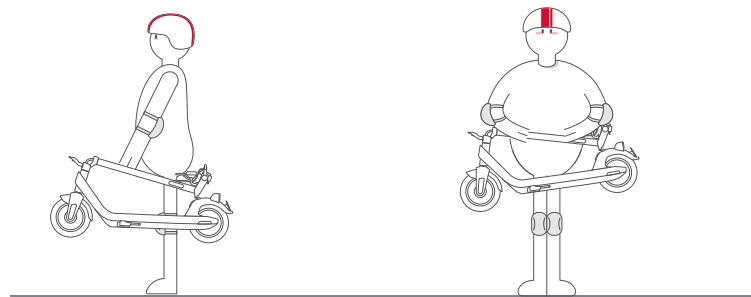

Handling

Fold and then hold the standpipe with one hand or both hands before transport.

Parking instructions

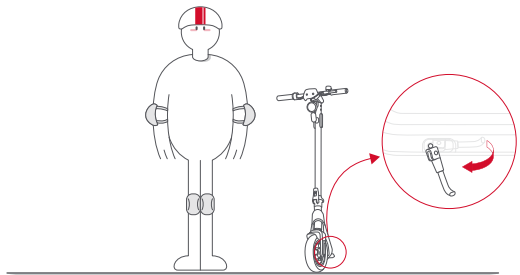

Please turn on the parking device after use and park the vehicle. Please turn on the parking device before use.

Charger connection

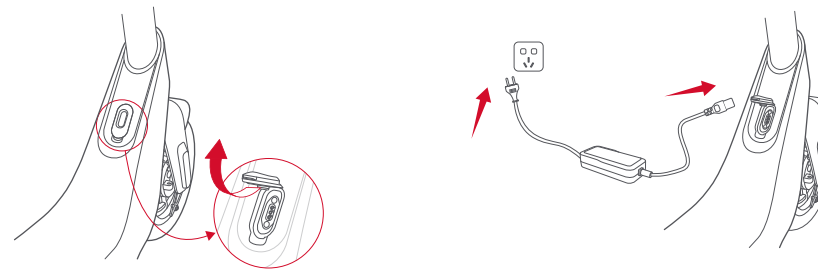

Firstly open the charging port, then plug the charging plug into the body charging port and finally connect the power supply to charge. After the completion of charging, fastening down the charging port to beware of water intake.

⚠ CAUTION

- Do not charge when the charging port, charger or power socket is wet.
- Turn off the power before charging.
- The original charger provided by Niu can be only used when charging. Do not use any other type of chargers.
- Do not charge or continue using the battery if the battery is damaged or flooded.
- Fasten the rubber plug of the charging port before or after charging.
- Do not charge outdoors.
- Do not ride while charging.

Fast locking

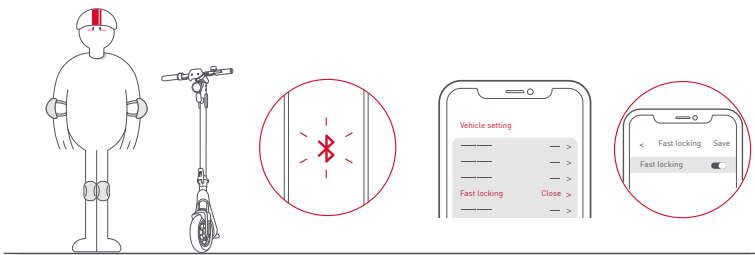

Lock

01

Connect your electric scooter to the installed APP of Niu Technologies via Bluetooth, and activate the fast locking function in the APP.

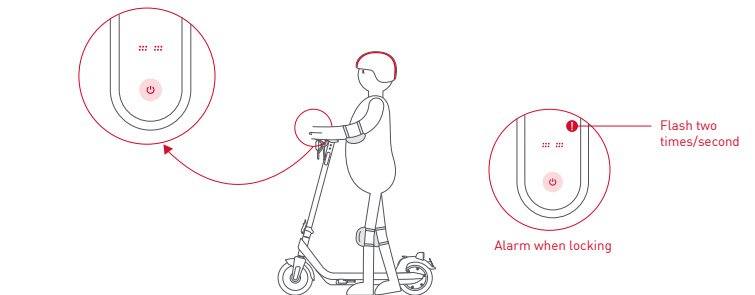

02

Long press the On/Off button for 5s to lock your scooter, with the lock icon displayed on the meter.

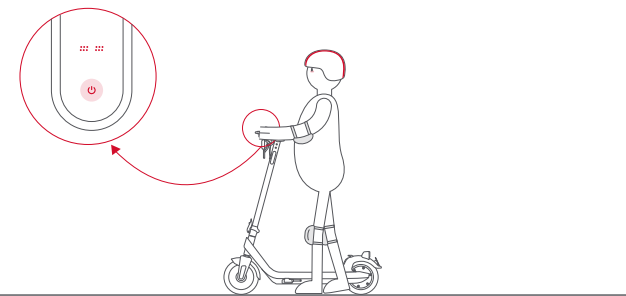

Unlock

01

Long press the On/Off button for 2s to start your scooter.

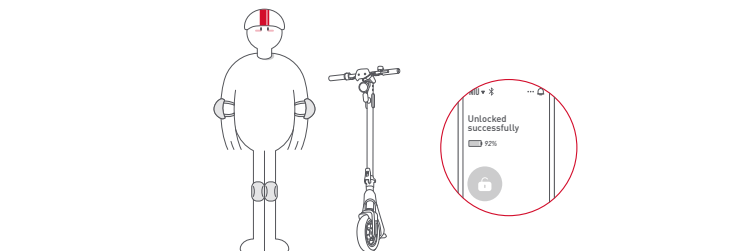

02

Click the Unlock button on the APP interface to unlock your scooter connected to the APP.

Downloading the APP



NIU E-Scooter App

Scan the QR code on the left, install the Niu E-scooter App, bind and activate the scooter according to the prompts.

Safety risks are present when using the scooter. You must complete the teaching guide for newbies through the APP before initial use. For your safety, the new scooter is inactive and will be locked in the E-save position until you complete all the teaching contents for newbies. You need to install the Niu Technologies app on your mobile device, connect it to your kick scooter via Bluetooth, complete the activation and binding according to the prompts in app, and learn the contents for newbies. You can enjoy all the functions of the kick scooter after all these contents are completed.

Your mobile phone needs to be the Bluetooth functional version 4.2 or above; iOS system version 9.0 or above; AndroidTM system version Android 5.0 or above.

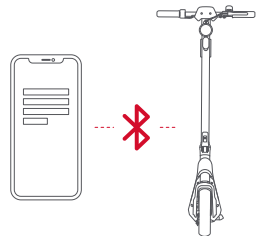

01 After installing the APP, please log in and register.

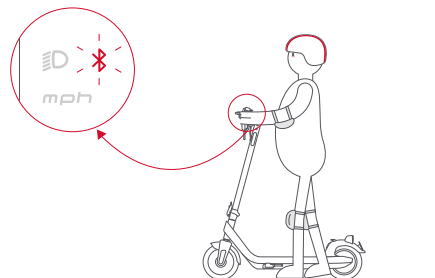

02 Long press the button to power it up and the Bluetooth icon will start flashing.

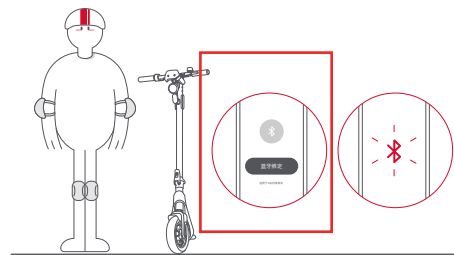

03 Click [Me], [Device Binding] and [Bind with Bluetooth] to connect to your scooter. The scooter beeps, indicating that the Bluetooth is connected successfully. The icon will stop flashing and keep on once the connection is successful.

- * The account paired with the Bluetooth for the first time is the vehicle owner. If the vehicle owner changes the mobile connection, the Bluetooth pairing needs to be reset.
- * In case of changing the account connection, the original vehicle owner's account needs to be unbound.

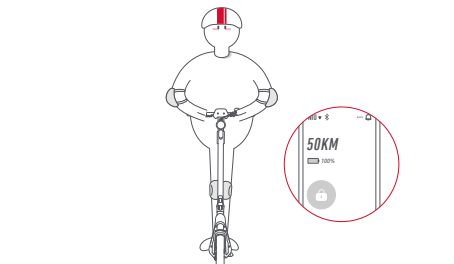



04 Activate the scooter according to the prompts of APP and learn how to drive safely. Now you can get your scooter started, check the status of your scooter and interact with other riders through the APP. Enjoy yourself!

ARE YOU READY?

Precautions before riding:

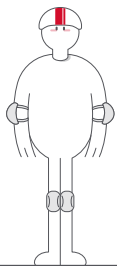
- Ensure that the steering system and folding system are working properly, and the components are tightly secured.
- Check whether the wheel axle is fastened to the body to ensure that the wheel can rotate normally and the brake system can work normally.
- Please check the tire pressure before riding. It is recommended that the tire pressure be between 45-50psi.
- Check the wear of the tires and brake pads. If the wear is serious and need to be replaced, please contact the dealer in time.



 The risk of fall injuries is present during practice, so please wear a helmet and protectors all the way.

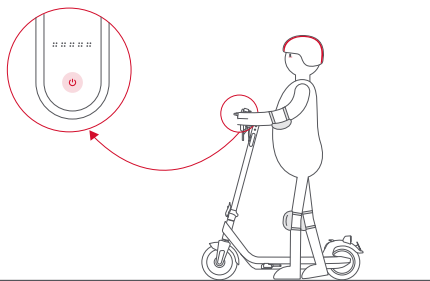

01 Turn on the power and check the power indicator.

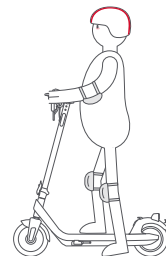

02 Stand on the pedal with one foot and push back with the other foot.

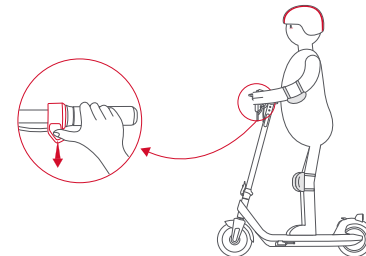

03 When the kick scooter is sliding, stand on the pedal with the other foot, keep both feet stable, while gently pressing the throttle twistgrip. (The speed above 4km/h will start the throttle)

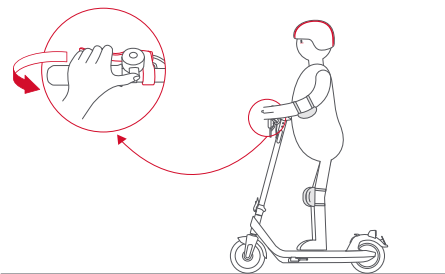

04 Release the throttle twistgrip and use the energy recovery to achieve the effect of deceleration. Emergency braking requires powerful grip on both sides of the brake levers.

** The deceleration can be adjusted through energy recovery within the app.*

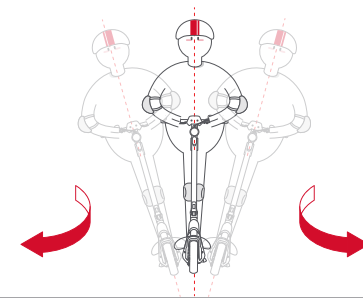

05 The body should lean slightly to the direction of turning, and slowly turn the handlebar during a turn.