



# FCC TEST REPORT

## FCC ID:2AZ4X-AB0009

**Report Number** ..... : ZKT-2110225629E

Date of Test ..... Oct. 19, 2021 to Nov. 03, 2021

Date of issue ..... : Nov. 03, 2021

Total number of pages ..... 21

Test Result ..... : PASS

**Testing Laboratory** ..... : **Shenzhen ZKT Technology Co., Ltd.**

Address ..... : 1/F, No. 101, Building B, No. 6, Tangwei Community Industrial Avenue, Fuhai Street, Bao'an District, Shenzhen, China

**Applicant's name** ..... : **Dongguan Leaper Electronic Technology CO.,LTD**

Address ..... : NO.22, Xinbao second Street, Dalang new town, Dongguan City, China

**Manufacturer's name** ..... : **Dongguan Leaper Electronic Technology CO.,LTD**

Address ..... : NO.22, Xinbao second Street, Dalang new town, Dongguan City, China

**Test specification:**

Standard ..... : FCC CFR Title 47 Part 15 Subpart C

Test procedure ..... : /

Non-standard test method ..... : N/A

**Test Report Form No.** ..... : TRF-EL-107\_V0

**Test Report Form(s) Originator** .... : ZKT Testing

**Master TRF** ..... : Dated: 2020-01-06

This device described above has been tested by ZKT, and the test results show that the equipment under test (EUT) is in compliance with the FCC requirements. And it is applicable only to the tested sample identified in the report.

This report shall not be reproduced except in full, without the written approval of ZKT, this document may be altered or revised by ZKT, personal only, and shall be noted in the revision of the document.

**Product name** ..... : **WIRELESS CHARGER**

Trademark ..... : N/A

Model/Type reference ..... : AB0009

Ratings ..... : Input: DC 5V 1.5A  
Wireless Output: 5W



**Testing procedure and testing location:**

**Testing Laboratory**.....: **Shenzhen ZKT Technology Co., Ltd.**

**Address**.....: 1/F, No. 101, Building B, No. 6, Tangwei Community Industrial Avenue, Fuhai Street, Bao'an District, Shenzhen, China

**Tested by (name + signature)**.....: **Alen He**

**Reviewer (name + signature)**.....: **Joe Liu**

**Approved (name + signature)**.....: **Lake Xie**



## TABLE OF CONTENTS

<b>1. VERSION</b>	<b>4</b>
<b>2. TEST SUMMARY</b>	<b>5</b>
2.1 TEST FACILITY	6
2.2 MEASUREMENT UNCERTAINTY	6
<b>3. GENERAL INFORMATION</b>	<b>7</b>
3.1 GENERAL DESCRIPTION OF EUT	7
3.2 Test mode	7
3.3 Block Diagram of EUT Configuration	7
3.4 Test Conditions	7
3.5 Description Of Support Units (Conducted Mode)	8
3.6 EQUIPMENTS LIST FOR ALL TEST ITEMS	9
<b>4. CONDUCTED EMISSION TEST</b>	<b>10</b>
4.1 CONDUCTED EMISSION MEASUREMENT	10
4.1.1 POWER LINE CONDUCTED EMISSION Limits	10
4.1.2 TEST PROCEDURE	10
4.1.3 DEVIATION FROM TEST STANDARD	10
4.1.4 TEST SETUP	11
4.1.5 EUT OPERATING CONDITIONS	11
4.6 Test Result	12
<b>5. RADIATED EMISSION MEASUREMENT</b>	<b>14</b>
5.1 Radiated Emission Limits	14
5.2 Anechoic Chamber Test Setup Diagram	15
5.3 Test Procedure	15
5.4 DEVIATION FROM TEST STANDARD	15
5.5 Test Result	16
<b>6. BANDWIDTH TEST</b>	<b>19</b>
<b>7. TEST SETUP PHOTO</b>	<b>21</b>
<b>8. EUT CONSTRUCTIONAL DETAILS</b>	<b>21</b>



**1. VERSION**

Report No.	Version	Description	Approved
ZKT-2110225629E	Rev.01	Initial issue of report	Nov. 03, 2021



## 2. TEST SUMMARY

Test Item	Section in CFR 47	Result
Antenna requirement	15.203	Pass
AC Power Line Conducted Emission	15.207	Pass
Spurious Emission	15.209(a)(f)	Pass
20dB Bandwidth	15.215	Pass

NOTE:

(1) "N/A" denotes test is not applicable in this Test Report



## 2.1 TEST FACILITY

Shenzhen ZKT Technology Co., Ltd.  
Add. : 1/F, No. 101, Building B, No. 6, Tangwei Community Industrial Avenue, Fuhai Street,  
Bao'an District, Shenzhen, China

FCC Test Firm Registration Number: 692225  
Designation Number: CN1299  
IC Registered No.: 27033

## 2.2 MEASUREMENT UNCERTAINTY

The reported uncertainty of measurement  $y \pm U$ , where expanded uncertainty  $U$  is based on a standard uncertainty multiplied by a coverage factor of  $k=2$ , providing a level of confidence of approximately 95 %.

No.	Item	Uncertainty
1	3m chamber Radiated spurious emission(30MHz-1GHz)	U=4.3dB
2	3m chamber Radiated spurious emission(1GHz-18GHz)	U=4.5dB
3	3m chamber Radiated spurious emission(18GHz-40GHz)	U=3.34dB
4	Conducted Adjacent channel power	U=1.38dB
5	Conducted output power uncertainty Above 1G	U=1.576dB
6	Conducted output power uncertainty below 1G	U=1.28dB
7	humidity uncertainty	U=5.3%
8	Temperature uncertainty	U=0.59°C
9	Radiated disturbance(30MHz-1000MHz)	U=4.8dB
10	Radiated disturbance(1GHz-6GHz)	U=4.9dB
11	Radiated disturbance(1GHz-18GHz)	U=5.0dB



### 3. GENERAL INFORMATION

#### 3.1 GENERAL DESCRIPTION OF EUT

Product Name:	WIRELESS CHARGER
Model No.:	AB0009
Model Difference:	N/A
Sample No.	ZKT-2110225629-1
Serial No.:	N/A
Hardware version:	H1.0
Software version:	S1.0
Operation Frequency:	115kHz ~ 205KHz
Modulation type:	MSK
Antenna Type:	Inductive loop coil Antenna
Antenna gain:	0dBi
Power supply:	Input: DC 5V 1.5A Wireless Output: 5W

#### 3.2 Test mode

Transmitting mode	Keep the EUT in continuously transmitting mode
<i>Remark: During the test, the test voltage was tuned from 85% to 115% of the nominal rated supply voltage, and found that the worst case was under the nominal rated supply condition. So the report just shows that condition's data.</i>	

#### 3.3 Block Diagram of EUT Configuration

##### Conducted Emission

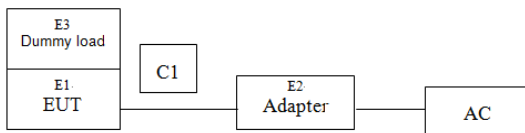

##### Radiated Emission

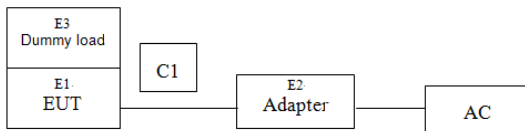

#### 3.4 Test Conditions

Temperature: 23~26°C

Relative Humidity: 54~63 %



### 3.5 Description Of Support Units (Conducted Mode)

The EUT has been tested as an independent unit together with other necessary accessories or support units. The following support units or accessories were used to form a representative test configuration during the tests.

Item	Equipment	Mfr/Brand	Model/Type No.	Series No.	Note
E1	WIRELESS CHARGER	N/A	AB0009	N/A	EUT
E2	Adapter	N/A	ZKT-002	N/A	Auxiliary
E3	Phone	XIAOMI	DL01	N/A	Auxiliary

Item	Shielded Type	Ferrite Core	Length	Note
C1	NO	NO	1.0M	DC cable unshielded

Note:

- (1) The support equipment was authorized by Declaration of Confirmation.
- (2) For detachable type I/O cable should be specified the length in cm in 『Length』 column.
- (3) “YES” is means “shielded” “with core”; “NO” is means “unshielded” “without core”.





### 3.6 EQUIPMENTS LIST FOR ALL TEST ITEMS

#### Radiation Test equipment

Item	Equipment	Manufacturer	Type No.	Serial No.	Last calibration	Calibrated until
1	Spectrum Analyzer (9kHz-26.5GHz)	KEYSIGHT	9020A	MY45109572	Sep. 22, 2021	Sep. 21, 2022
2	Spectrum Analyzer (1GHz-40GHz)	Agilent	E4446A	100363	Sep. 22, 2021	Sep. 21, 2022
3	Test Receiver (9kHz-7GHz)	R&S	ESCI7	101169	Sep. 22, 2021	Sep. 21, 2022
4	Bilog Antenna (30MHz-1400MHz)	Schwarzbeck	VULB9168	00877	Sep. 22, 2021	Sep. 21, 2022
5	Horn Antenna (1GHz-18GHz)	SCHWARZBEC K	BBHA9120D	1541	Sep. 22, 2021	Sep. 21, 2022
6	Horn Antenna (18GHz-40GHz)	A.H. System	SAS-574	588	Sep. 22, 2021	Sep. 21, 2022
7	Amplifier (30-1000MHz)	EM Electronics	EM330 Amplifier	N/A	Sep. 22, 2021	Sep. 21, 2022
8	Amplifier (1GHz-40GHz)	全聚达	DLE-161	097	Sep. 22, 2021	Sep. 21, 2022
9	Loop Antenna (9KHz-30MHz)	SCHWARZBEC K	FMZB1519B	014	Sep. 22, 2021	Sep. 21, 2022
10	RF cables1 (9kHz-30MHz)	N/A	9kHz-30MHz	N/A	Sep. 22, 2021	Sep. 21, 2022
11	RF cables2 (30MHz-1GHz)	N/A	30MHz-1GHz	N/A	Sep. 22, 2021	Sep. 21, 2022
12	RF cables3 (1GHz-40GHz)	N/A	1GHz-40GHz	N/A	Sep. 22, 2021	Sep. 21, 2022
13	CMW500 Test	R&S	CMW500	106504	Sep. 22, 2021	Sep. 21, 2022
14	ESG Signal Generator	Agilent	E4421B	GB40051203	Sep. 22, 2021	Sep. 21, 2022
15	Signal Generator	Agilent	N5182A	MY47420215	Sep. 22, 2021	Sep. 21, 2022
16	D.C. Power Supply	LongWei	TPR-6405D	\	\	\
17	Software	Frad	EZ-EMC	FA-03A2 RE	\	\

#### Conduction Test equipment

Item	Kind of Equipment	Manufacturer	Type No.	Serial No.	Last calibration	Calibrated until
1	LISN	R&S	ENV216	101471	Sep. 22, 2021	Sep. 21, 2022
2	LISN	CYBERTEK	EM5040A	E185040014 9	Sep. 22, 2021	Sep. 21, 2022
3	Test Cable	N/A	C01	N/A	Sep. 22, 2021	Sep. 21, 2022
4	Test Cable	N/A	C02	N/A	Sep. 22, 2021	Sep. 21, 2022
5	EMI Test Receiver	R&S	ESRP3	101946	Sep. 22, 2021	Sep. 21, 2022
6	Absorbing Clamp	DZ	ZN23201	N/A	Sep. 22, 2021	Sep. 21, 2022



#### 4. CONDUCTED EMISSION TEST

##### 4.1 CONDUCTED EMISSION MEASUREMENT

Test Requirement:	FCC Part15 C Section 15.207
Test Method:	ANSI C63.10:2013
Test Frequency Range:	150KHz to 30MHz
Receiver setup:	RBW=9KHz, VBW=30KHz, Sweep time=auto

##### 4.1.1 POWER LINE CONDUCTED EMISSION Limits

FREQUENCY (MHz)	Limit (dBuV)		Standard
	Quas -peak	Average	
0.15 -0.5	66 - 56 *	56 - 46 *	FCC
0.50 -5.0	56.00	46.00	FCC
5.0 -30.0	60.00	50.00	FCC

Note:

(1) \*Decreases with the logarithm of the frequency.

##### 4.1.2 TEST PROCEDURE

- a. The EUT was placed 0.8 meters from the horizontal ground plane with EUT being connected to the power mains through a line impedance stabilization network (LISN). All other support equipments powered from additional LISN(s). The LISN provide 50 Ohm/ 50uH of coupling impedance for the measuring instrument.
- b. Interconnecting cables that hang closer than 40 cm to the ground plane shall be folded back and forth in the center forming a bundle 30 to 40 cm long.
- c. I/O cables that are not connected to a peripheral shall be bundled in the center. The end of the cable may be terminated, if required, using the correct terminating impedance. The overall length shall not exceed 1 m.
- d. LISN at least 80 cm from nearest part of EUT chassis.
- e. For the actual test configuration, please refer to the related Item –EUT Test Photos.

##### 4.1.3 DEVIATION FROM TEST STANDARD

No deviation



#### 4.1.4 TEST SETUP

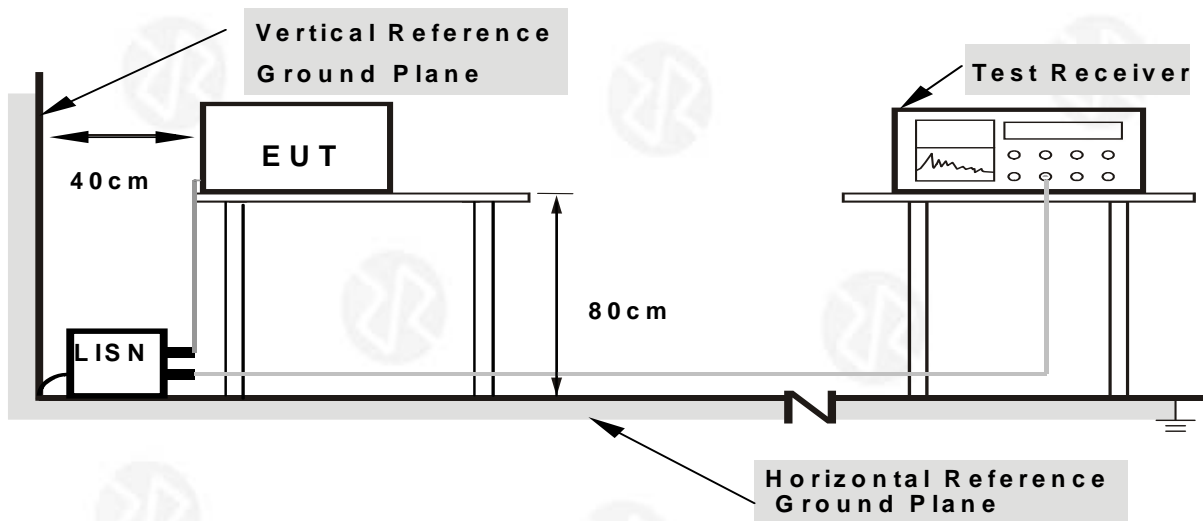

- Note:**
1. Support units were connected to second LISN.
  2. Both of LISNs (AMN) are 80 cm from EUT and at least 80 cm from other units and other metal planes

#### 4.1.5 EUT OPERATING CONDITIONS

The EUT was configured for testing in a typical fashion (as a customer would normally use it). The EUT has been programmed to continuously transmit during test. This operating condition was tested and used to collect the included data.



4.1.6 Test Result

Temperature:	26°C	Relative Humidity:	54%
Pressure:	101kPa	Phase :	L
Test Voltage :	AC 120V/60Hz		

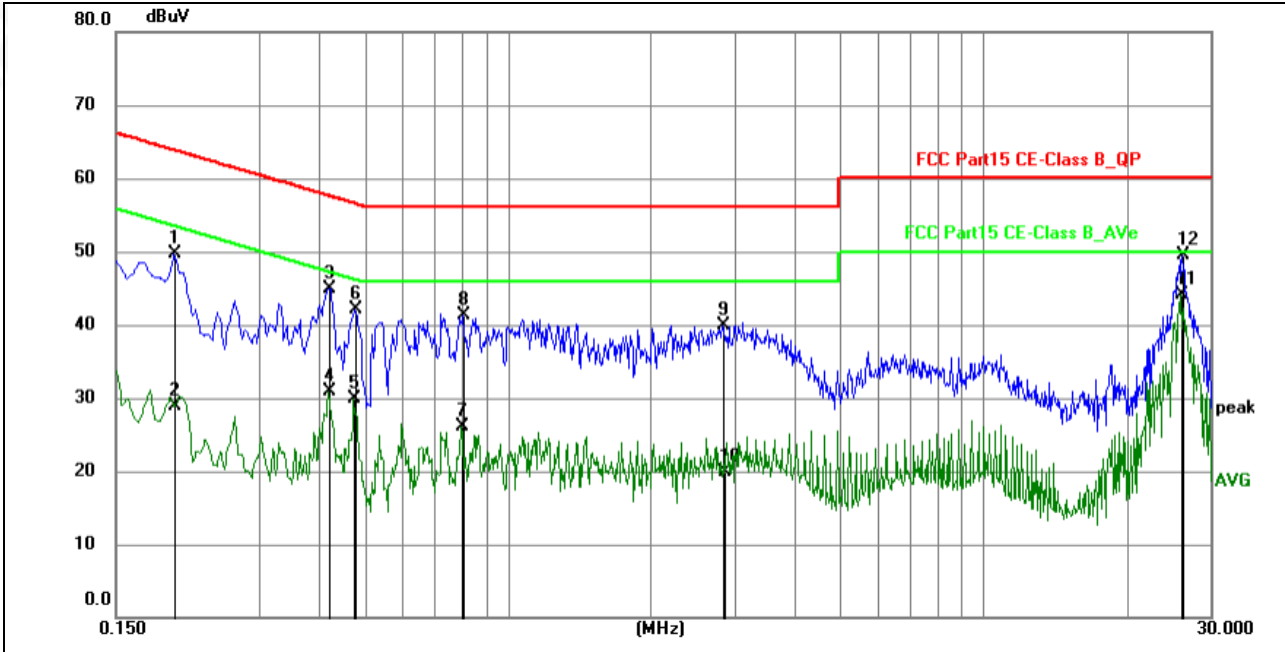

No.	Frequency (MHz)	Reading (dBuV)	Factor (dB)	Level (dBuV)	Limit (dBuV)	Margin (dB)	Detector	P/F	Remark
1	0.1995	37.82	11.93	49.75	63.63	-13.88	QP	P	
2	0.1995	16.94	11.93	28.87	53.63	-24.76	AVG	P	
3	0.4200	34.08	10.90	44.98	57.45	-12.47	QP	P	
4	0.4200	20.07	10.90	30.97	47.45	-16.48	AVG	P	
5	0.4740	19.23	10.66	29.89	46.44	-16.55	AVG	P	
6	0.4785	31.40	10.64	42.04	56.37	-14.33	QP	P	
7	0.7980	15.65	10.48	26.13	46.00	-19.87	AVG	P	
8	0.8070	30.73	10.48	41.21	56.00	-14.79	QP	P	
9	2.8365	29.92	9.98	39.90	56.00	-16.10	QP	P	
10	2.8410	9.99	9.98	19.97	46.00	-26.03	AVG	P	
11	26.1150	34.19	9.92	44.11	50.00	-5.89	AVG	P	
12	26.2590	39.57	9.92	49.49	60.00	-10.51	QP	P	

Notes:

1. An initial pre-scan was performed on the line and neutral lines with peak detector.
2. Quasi-Peak and Average measurement were performed at the frequencies with maximized peak emission.
3. Measurement Level = Reading level + Correct Factor



Temperature:	26°C	Relative Humidity:	54%
Pressure:	101kPa	Phase :	N
Test Voltage :	AC 120V/60Hz		

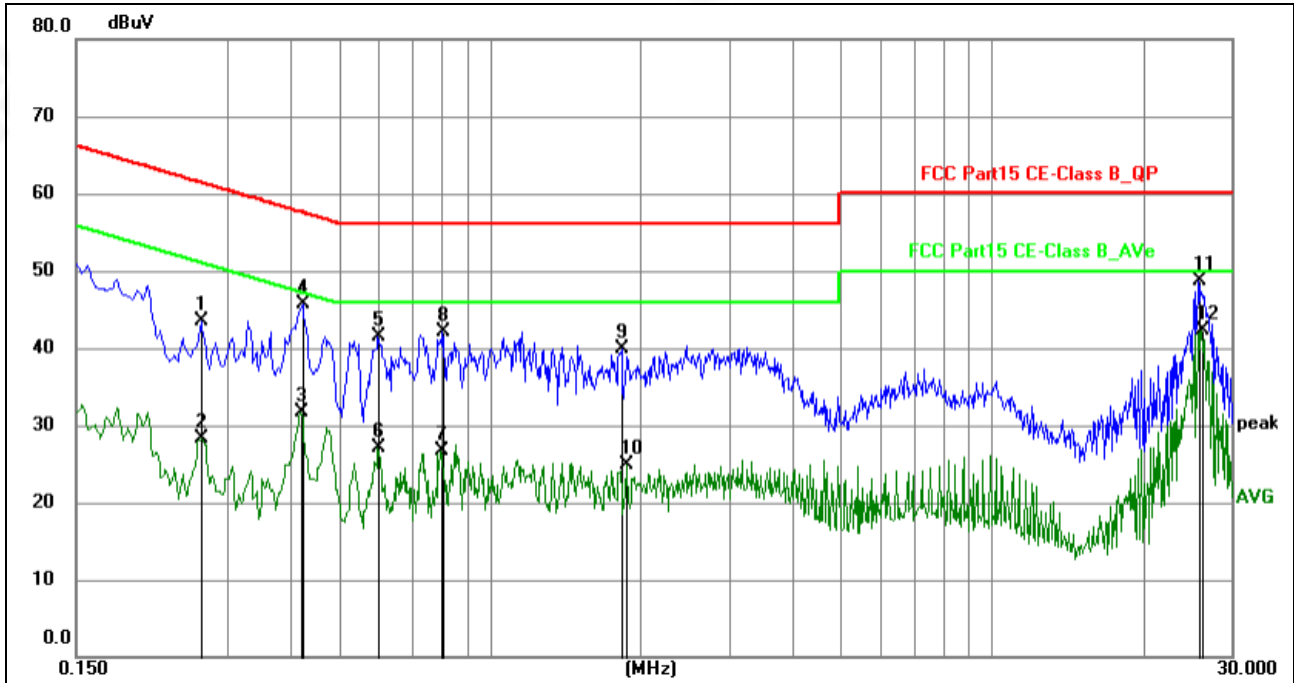

No.	Frequency (MHz)	Reading (dBuV)	Factor (dB)	Level (dBuV)	Limit (dBuV)	Margin (dB)	Detector	P/F	Remark
1	0.2670	31.84	11.61	43.45	61.21	-17.76	QP	P	
2	0.2670	16.79	11.61	28.40	51.21	-22.81	AVG	P	
3	0.4200	20.78	10.90	31.68	47.45	-15.77	AVG	P	
4	0.4245	34.78	10.88	45.66	57.36	-11.70	QP	P	
5	0.6000	30.89	10.52	41.41	56.00	-14.59	QP	P	
6	0.6000	16.54	10.52	27.06	46.00	-18.94	AVG	P	
7	0.7980	16.28	10.48	26.76	46.00	-19.24	AVG	P	
8	0.8070	31.67	10.48	42.15	56.00	-13.85	QP	P	
9	1.8330	29.76	10.23	39.99	56.00	-16.01	QP	P	
10	1.8690	14.70	10.22	24.92	46.00	-21.08	AVG	P	
11	25.8000	38.70	9.92	48.62	60.00	-11.38	QP	P	
12	26.2410	32.41	9.92	42.33	50.00	-7.67	AVG	P	

Notes:

1. An initial pre-scan was performed on the line and neutral lines with peak detector.
2. Quasi-Peak and Average measurement were performed at the frequencies with maximized peak emission.
3. Measurement Level = Reading level + Correct Factor



### 5. RADIATED EMISSION MEASUREMENT

Test Requirement:	FCC Part15 C Section 15.209				
Test Method:	ANSI C63.10:2013				
Test Frequency Range:	9kHz to 1GHz				
Test site:	Measurement Distance: 3m				
Receiver setup:	Frequency	Detector	RBW	VBW	Value
	9KHz-150KHz	Quasi-peak	200Hz	600Hz	Quasi-peak
	150KHz-30MHz	Quasi-peak	9KHz	30KHz	Quasi-peak
	30MHz-1GHz	Quasi-peak	100KHz	300KHz	Quasi-peak
	Above 1GHz	Peak	1MHz	3MHz	Peak
		Peak	1MHz	10Hz	Average

#### 5.1 Radiated Emission Limits

##### Limits for frequency below 30MHz

Frequency	Limit (uV/m)	Measurement Distance(m)	Remark
0.009-0.490	2400/F(kHz)	300	Quasi-peak Value
0.490-1.705	24000/F(kHz)	30	Quasi-peak Value
1.705-30	30	30	Quasi-peak Value

##### Limits for frequency Above 30MHz

Frequency	Limit (dBuV/m @3m)	Remark
30MHz-88MHz	40.00	Quasi-peak Value
88MHz-216MHz	43.50	Quasi-peak Value
216MHz-960MHz	46.00	Quasi-peak Value
960MHz-1GHz	54.00	Quasi-peak Value
Above 1GHz	54.00	Average Value
	74.00	Peak Value





## 5.2 Anechoic Chamber Test Setup Diagram

(A) Radiated Emission Test-Up Frequency Below 30MHz

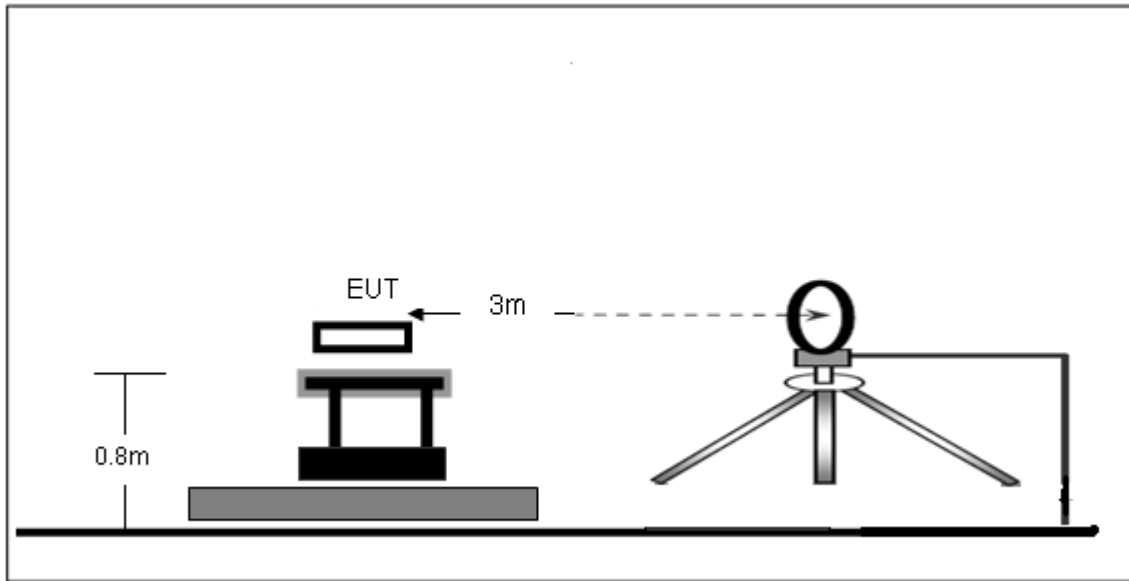

(B) Radiated Emission Test-Up Frequency 30MHz~1GHz

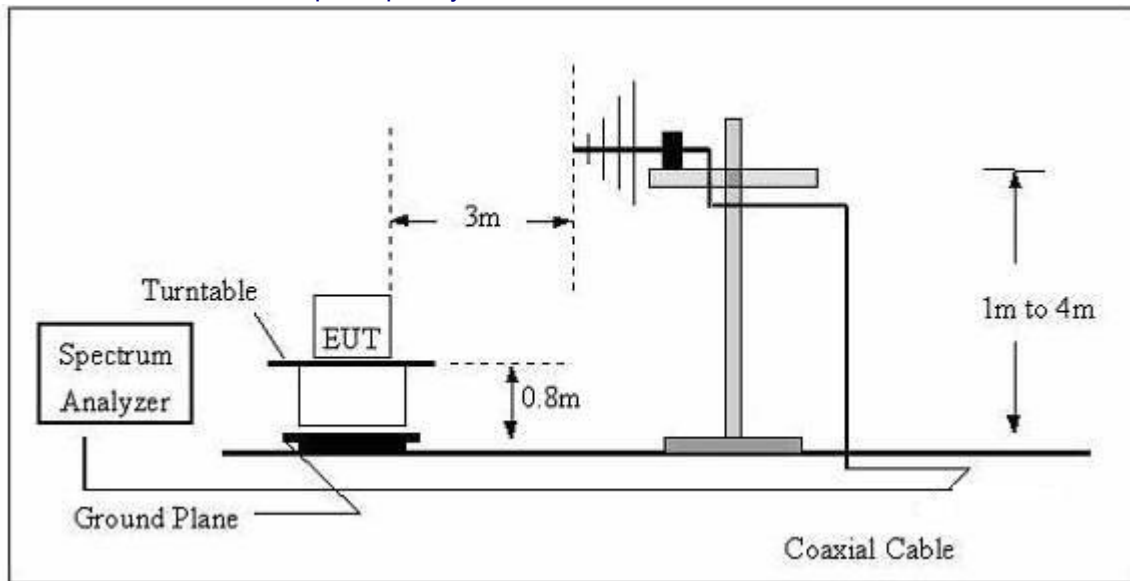

The radiated emission tests were performed in the 3 meters chamber test site, using the setup accordance with the ANSI C63.10-2013. The specification used was the FCC 15.209 and FCC 15.205 limits.

## 5.3 Test Procedure

The EUT is placed on a turn table which is 0.8 meter above ground. The turn table can rotate 360 degrees to determine the position of the maximum emission level. The EUT is set 3 meters away from the receiving antenna which is mounted on a antenna tower. The antenna can move up and down between 1 to 4 meters to find out the maximum emission level. Broadband antenna (calibrated by dipole antenna) are used as a receiving antenna. Both horizontal and vertical polarization of the antenna are set on measurement.

## 5.4 DEVIATION FROM TEST STANDARD

No deviation



5.5 Test Result

Measurement data:

Note: Limit dBuV/m @3m = Limit dBuV/m @300m+ 80

Limit dBuV/m @3m = Limit dBuV/m @30m + 40

9 kHz~30 MHz

Frequency (kHz)	Meter Reading (dBμV)	Factor (dB)	Emission Level (dBμV/m)	Limits (dBμV/m)	Margin (dB)	Detector Type
24.8000	39.40	20.15	59.67	139.72	-80.05	PK
24.8000	36.13	20.15	56.52	119.72	-63.20	AV
56.7000	50.62	20.33	70.49	132.53	-62.04	PK
56.7000	46.38	20.33	66.91	112.53	-45.62	AV
121.6000	68.25	20.55	88.87	125.91	-37.04	PK
121.6000	63.65	20.55	53.12	105.91	-52.79	AV
685.1000	31.12	20.64	52.22	70.89	-18.67	QP
965.6100	35.16	21.26	56.92	67.91	-10.99	QP
1222.3300	24.65	22.32	57.56	65.86	-8.30	QP

Note:

Pre-scan in the all of mode, the worst case in of was recorded.

Factor = antenna factor + cable loss – pre-amplifier.

Margin = Emission Level- Limit.





30MHz-1GHz

Temperature:	26°C	Relative Humidity:	54%
Pressure:	101 kPa	Polarization:	Horizontal
Test Voltage:	AC 120V/60Hz		

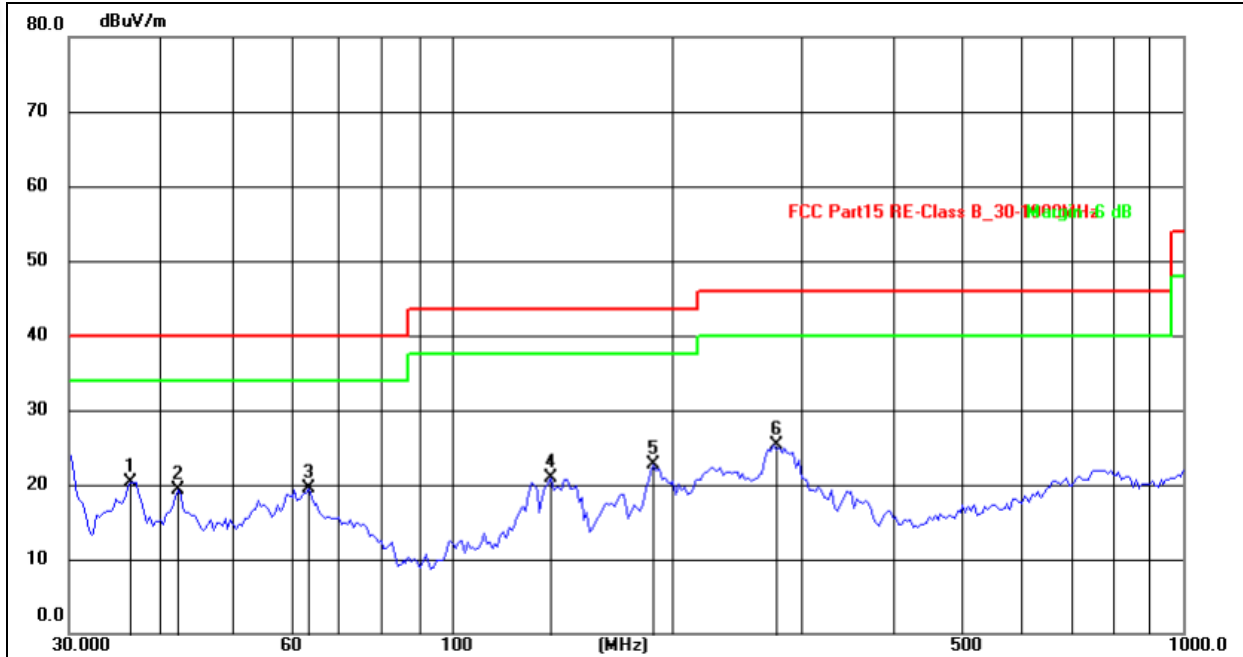

No.	Frequency (MHz)	Reading (dBuV)	Factor (dB/m)	Level (dBuV/m)	Limit (dBuV/m)	Margin (dB)	Detector
1	36.3814	35.12	-14.80	20.32	40.00	-19.68	QP
2	42.2281	33.33	-14.12	19.21	40.00	-20.79	QP
3	63.7588	34.70	-15.24	19.46	40.00	-20.54	QP
4	136.6993	38.45	-17.57	20.88	43.50	-22.62	QP
5	189.0743	41.85	-19.17	22.68	43.50	-20.82	QP
6	275.6399	41.70	-16.37	25.33	46.00	-20.67	QP



Temperature:	26°C	Relative Humidity:	54%
Pressure:	101kPa	Polarization:	Vertical
Test Voltage:	AC 120V/60Hz		

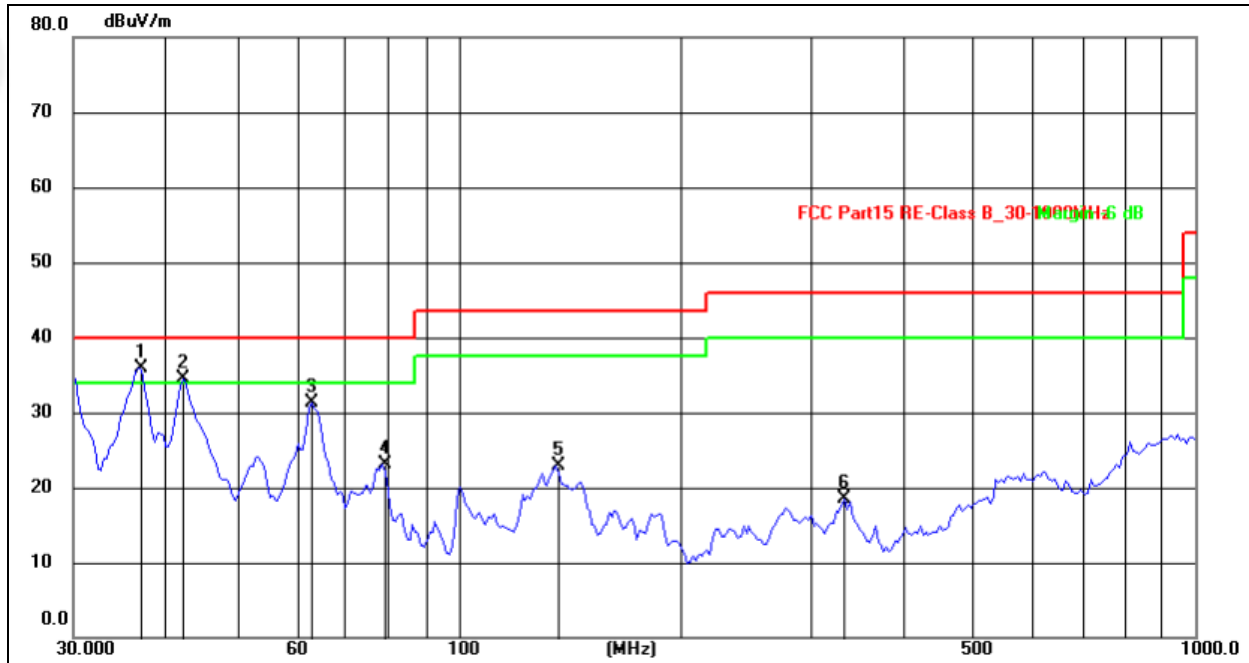

No.	Frequency (MHz)	Reading (dBuV)	Factor (dB/m)	Level (dBuV/m)	Limit (dBuV/m)	Margin (dB)	Detector
1	36.7018	53.18	-17.35	35.83	40.00	-4.17	QP
2	42.2281	51.51	-16.96	34.55	40.00	-5.45	QP
3	63.2023	49.86	-18.64	31.22	40.00	-8.78	QP
4	78.6888	44.58	-21.53	23.05	40.00	-16.95	QP
5	135.5062	44.25	-21.39	22.86	43.50	-20.64	QP
6	334.2722	37.73	-19.20	18.53	46.00	-27.47	QP

Remarks:

1. Final Level = Receiver Read level + Antenna Factor + Cable Loss – Preamplifier Factor
2. The emission levels of other frequencies are very lower than the limit and not show in test report.



## 6. BANDWIDTH TEST

1. Set RBW = 3 kHz.
2. Set the video bandwidth (VBW)  $\geq 3 \times$  RBW.
3. Detector = Peak.
4. Trace mode = max hold.
5. Sweep = auto couple.
6. Allow the trace to stabilize.
7. Measure the maximum width of the emission that is constrained by the frequencies associated with the two outermost amplitude points (upper and lower frequencies) that are attenuated by 20 dB relative to the maximum level measured in the fundamental emission.

### TEST SETUP

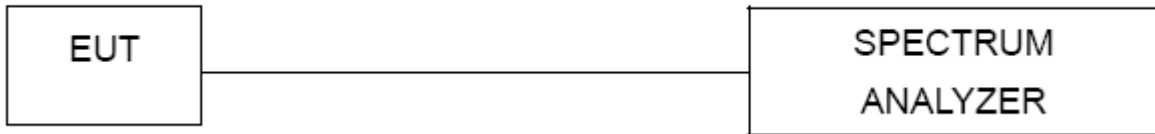



Temperature:	26 °C	Relative Humidity:	54%
Pressure:	101kPa		

Frequency (KHz)	20dB bandwidth (KHz)	99% bandwidth (KHz)	Result
144.6	20.00	18.220	Pass

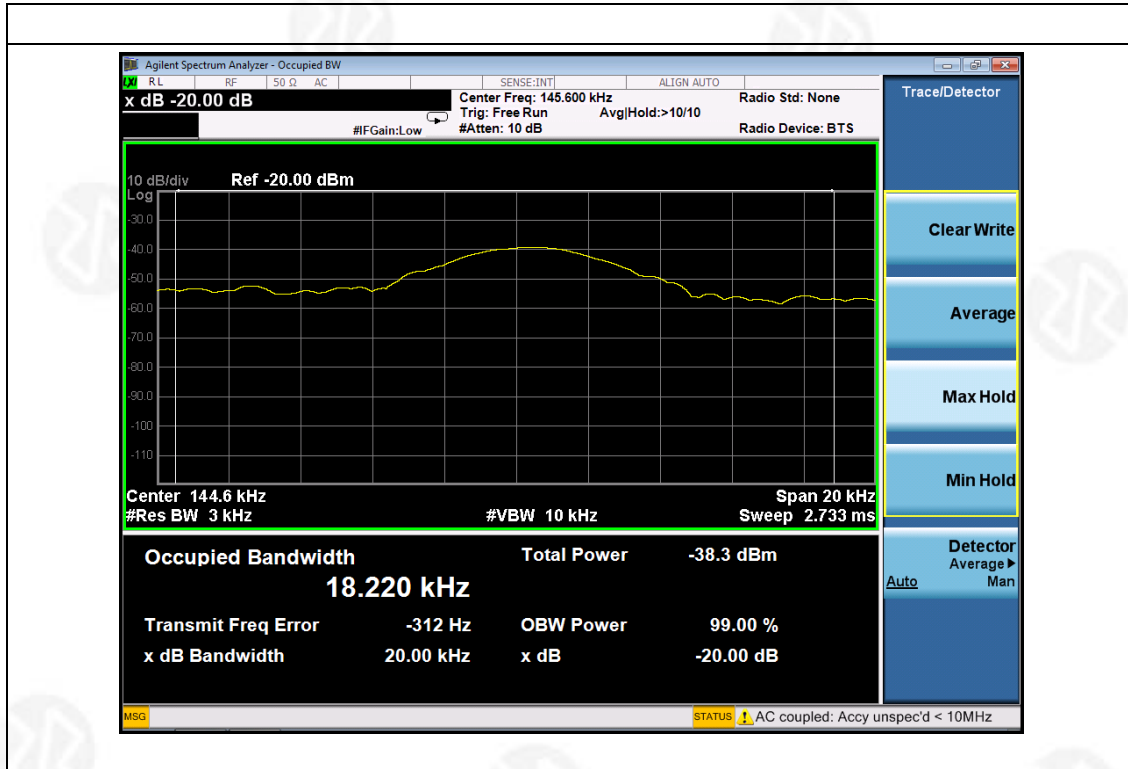



## 7. TEST SETUP PHOTO

Reference to the appendix I for details.

## 8. EUT CONSTRUCTIONAL DETAILS

Reference to the appendix II for details.

\*\*\*\*\* END OF REPORT \*\*\*\*\*