

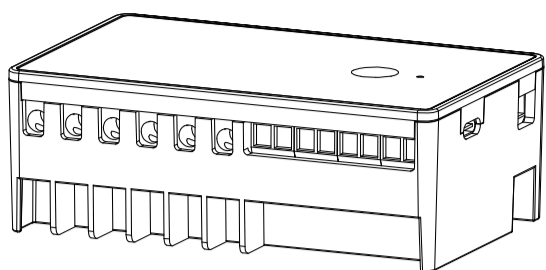

S2 MultiRelay
ZEN16 800LR



Scan to register your product for extended warranty and direct access to firmware files.



www.getzooz.com
ask@getzooz.com

FEATURES

- Powerful dry contact NO/NC relays to control loads up to 20 A for NO
- Perfect for DC motors, pumps, commercial gates, or HVAC equipment
- Control up to 2 connected loads independently or together
- Z-Wave or optional wall switch control (toggle or momentary type)
- Monitor inputs independently from output control
- Built-in timers for each relay to simplify automation
- Z-Wave Long Range for ultra reliable no-mesh communication
- Powered by 12-24 V DC/AC or USB C port for easy set-up
- Wall mounting and minimal design for clean installation
- 800 series Z-Wave chip for better range and faster control

SPECIFICATIONS

- Model Number: ZEN16 800LR
- Z-Wave Region: US / CA / MX
- Power: 12-24 V DC/AC or USB C (DON'T use laptop / tablet chargers)
- **Maximum Load:** NO relays: 20 A, NC relays: 10 A
- **Inputs:** dry contact or 12-24 V AC/DC (use 1 input type at a time!)
- Range: Up to 200 feet line of sight (up to 1300 feet with Long Range)
- Operating Temperature: 32-104° F (0-40° C)
- Installation and Use: Indoor only

CAUTION

This is an electrical device - please use caution when installing and operating the Universal Relay. Remote control of appliances may result in unintentional or automated activation of power.

BEFORE YOU INSTALL

This device is intended for installation in accordance with the National Electric Code and local regulations. It is recommended that a licensed electrician perform this installation. USE A SINGLE POWER SOURCE AT ALL TIMES.

WIRING: READ IT!

1. **CHECK THE LOAD:** make sure that the connected appliance does not exceed 20 A for normally open relays or 10 A for normally closed relays.
2. **POWER OFF:** turn the circuit power off in the breaker panel before you start. If handling wiring from a box with multiple circuits, turn power off at all of the circuits.
3. **REMOVE THE WALL SWITCH:** if the load is currently controlled by a wall switch, carefully remove it from the box and disconnect the wires from the switch.
4. **CONNECT THE UNIVERSAL RELAY:** follow the instructions in the appropriate diagram for your set-up. If you can't find your scenario in the diagrams below, please request custom instructions from our support team, we're happy to help: ask@getzooz.com

WIRING TIPS

TAKE PICTURES

Before you disconnect any wires, document your set-up and send us images of your existing installation so we can help if needed.

GATHER YOUR TOOLS

Always use the correct screwdriver size for the terminal screws on your Universal Relay and wall switches (if connecting them). Use appropriate electrical tools when cutting, prepping, and stripping electrical wires. If you don't have the necessary tools to perform the installation or are not sure which tools to use or how, please hire an electrician to complete the installation for you.

SAFETY FIRST

Follow the National Electrical Code and your local safety regulations when performing the installation, including (but not limited to), choosing the correct gauge of jumper wires. The recommended gauge for 15 Amp circuits is 14 AWG and 12 AWG for 20 Amp circuits.

HOW TO SECURE WIRES IN TERMINALS: first, unscrew the appropriate terminal's screw just far enough so there is a clear opening in the terminal for the wire to go in. Make sure the wire is stripped at the right length and perfectly straight before you insert it into the terminal. Once you put the wire in the terminal, carefully screw the terminal screw back in to hold down the wire. Check the connection by gently pulling on the connected wire to make sure it's fixed securely.

5. POWER THE UNIVERSAL RELAY: connect the USB C power source to the MultiRelay **or** use the "+" "-" terminals on the device to bring low voltage power to it. **Never use both at the same time.** In both cases you'll need a standard 1 A power adapter to plug into a standard 120 VAC receptacle. **Do NOT use with laptop or tablet chargers,** they require a large battery on load to activate.

WHAT'S WHAT

INPUT TERMINALS



RELAY TERMINALS



S1 C: wall switch to control R1 or dry contact sensor to monitor leaks (max 40k Ohm when on), open/close status, or motion.

C VC: 12-24 V DC / AC input to control R1. **NEVER use C VC and S1 C together!** Only one type of input can be used at any given time.

S2 C: wall switch to control R2 or dry contact sensor to monitor leaks, open/close status, or motion.

C VC: 12-24 V DC / AC input to control R2. **NEVER use C VC and S1 C together!** Only one type of input can be used at any given time.

NC C R1: normally closed relay controlling any load up to 10 A.

NO C R1: normally open relay controlling any load up to 20 A.

NC C R2: normally closed relay controlling any load up to 10 A.

NO C R2: normally open relay controlling any load up to 20 A.

WIRING EXAMPLE

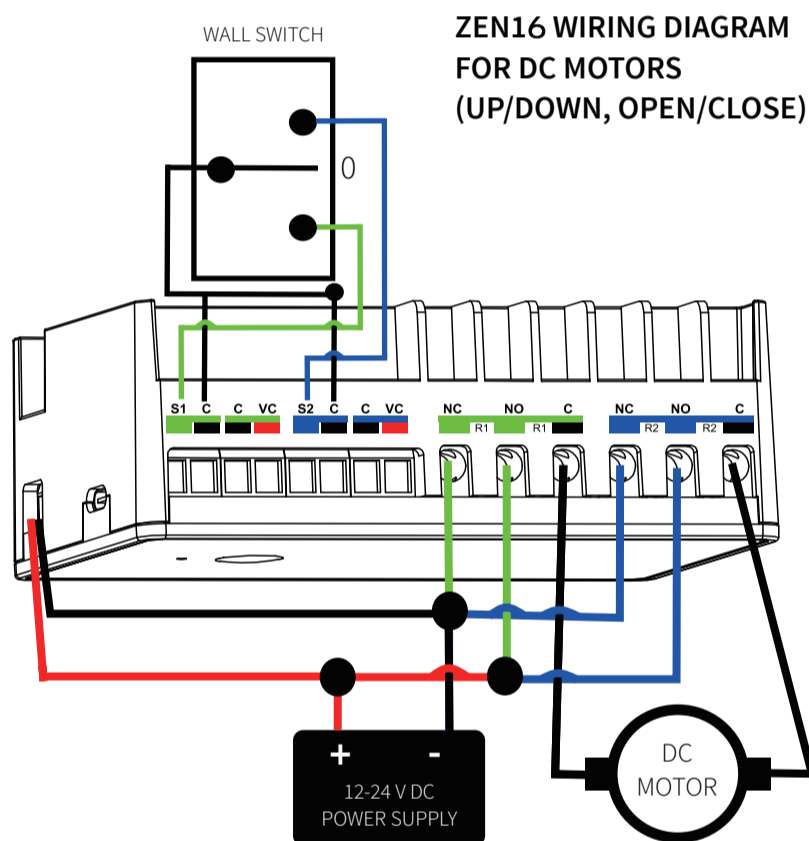

WIRING GUIDE

Here are some general wiring examples on how to use the ZEN16 dry contact relays in the most popular applications. Please make sure you understand how dry contact relays work before proceeding and always request a diagram or custom instructions from us if you're not sure how to complete your installation. Please do NOT experiment or attempt trial-and-error installation!

GARAGE DOOR OPENER: 2 bell wires from the opener to R1 C and R1 NO; 2 wires from the wall switch to S1 and C.

DOOR SENSOR INPUT: open/close sensor wires to S1 and C.

POOL PUMP: 120 / 220 V to R1 C, neutral to neutral, pump (load) to R1 NO.

WHOLE-HOUSE FAN: 120 V to R1 C, neutral to neutral, fan low speed to R1 NO; fan high speed to R2 NO.

LANDSCAPE LOW-VOLTAGE LIGHTING: one leg from power supply to R1 C, the other leg from power supply to lights; R1 NO to the other input on the lights.

SPRINKLERS: one leg from power supply to R1 C, the other leg from power supply to sprinkler valve; R1 NO to the other input on the valve. Automate up to 2 zones with R1 and R2.

LOW-VOLTAGE ALARM INPUT: 12-24 V wires to C and VC terminals.

LEAK ALARM INPUT: water sensor wires to S1 and C (max 40k Ohm)

1 POWER SUPPLY AT A TIME

Never use USB C and 12-24 V power supply together. Double power source will damage the device.

1 INPUT TYPE AT A TIME

Never connect inputs to S1 C and VC C for the same relay. Each relay can only have a single input type.

NO VOLTAGE ON "S" TERMINALS

The only input terminals that accept voltage are the C VC terminals.

1. ADD DEVICE to your hub

Initiate inclusion (pairing) in the app (or web interface).

Not sure how? Use the camera on your phone to scan the QR code below for hub specific instructions.



2. Finalize inclusion at the device.

Click the Z-Wave button 3 times quickly to add the Universal Relay to your network.

Z-WAVE BUTTON 
3 x CLICK

The LED indicator will blink to signal communication and remain on for 2 seconds to confirm inclusion.

Choose your hub and scan the QR code with your phone's camera. Then click on the link to access step-by-step pairing instructions.



SmartThings



Hubitat



Z-Box Hub



Home Assistant

Get more tutorials and helpful tips at www.support.getzooz.com

NEED SOME HELP? ask@getzooz.com

TROUBLESHOOTING

The Universal Relay won't add to your system? Try this:

1. Initiate **EXCLUSION** and click the Z-Wave button 3 times quickly.
2. Click the Z-Wave button **4-5 times quickly** when adding it.
3. Bring your Universal Relay closer to the gateway controller (hub), it may be out of range.
4. Get troubleshooting tips for your hub at www.support.getzooz.com

EXCLUSION (REMOVING / UNPAIRING DEVICE)

1. Bring your Universal Relay close to the Z-Wave hub and power it
2. Put the Z-Wave hub into **exclusion mode** (not sure how to do that? ask@getzooz.com)
3. Click the Z-Wave button **3 times quickly**
4. Your hub will confirm exclusion and the Universal Relay will disappear from your controller's device list

FACTORY RESET

If your primary controller is missing or inoperable, you may need to reset the device to factory settings. To complete the reset process manually, **click the Z-Wave button 4 times quickly**, the LED indicator will light up, then **quickly click the Z-Wave button 4 times again**. The LED indicator will flash 3 times to confirm successful reset and will then turn off.

NOTE: All previously recorded activity and custom settings will be erased from the device's memory.

⚠ WARNING

- ✓ This product should be installed indoors upon completion of any building renovations.
- ✓ Prior to installation, the device should be stored in a dry, dust-and-mold-proof place.
- ✓ Do not install the device in a place with direct sun exposure, high temperature, or humidity.
- ✓ Keep away from chemicals, water, and dust.
- ✓ Ensure the device is never close to any heat source or open flame to prevent fire.
- ✓ Ensure the device is connected to an electric power source that does not exceed the maximum load power.
- ✓ No part of the device may be replaced or repaired by the user.



This product can be included and operated in any Z-Wave network with other Z-Wave certified devices from other manufacturers and/or other applications. All non-battery operated nodes within the network will act as repeaters regardless of vendor to increase reliability of the network.

This product features the latest Security 2 (S2) framework to remove smart home network hacking risks. This device is equipped with a unique authentication code for trusted wireless communication.

This is an ETL certified device. ETL, just like UL, is a Nationally Recognized Testing Laboratory. The ETL mark is proof of product compliance with North American safety standards.

COMMAND CLASSES

This device requires the following **command classes** to be supported and recognized by your Z-Wave controller:

COMMAND_CLASS_MULTI_CHANNEL_V4,
COMMAND_CLASS_SECURITY_2,
COMMAND_CLASS_SUPERVISION,
COMMAND_CLASS_FIRMWARE_UPDATE_MD_V5

COMMAND_CLASS_ZWAVEPLUS_INFO_V2,
COMMAND_CLASS_SWITCH_BINARY_V2,
COMMAND_CLASS_ASSOCIATION_V3,
COMMAND_CLASS_MULTI_CHANNEL_ASSOCIATION_V3,
COMMAND_CLASS_ASSOCIATION_GRP_INFO_V3,
COMMAND_CLASS_NOTIFICATION_V8,
COMMAND_CLASS_TRANSPORT_SERVICE_V2,
COMMAND_CLASS_VERSION_V2,
COMMAND_CLASS_SENSOR_BINARY_V2,
COMMAND_CLASS_MANUFACTURER_SPECIFIC,
COMMAND_CLASS_DEVICE_RESET_LOCALLY,
COMMAND_CLASS_POWERLEVEL,
COMMAND_CLASS_CONFIGURATION_V4,



Scan the QR code for more information on advanced settings for this device, including detailed steps for accessing parameters on the most popular hubs.

ADVANCED SETTINGS

Please refer to your hub's user guide for advanced programming instructions as they are a little different for every software.

Not sure where to start? Go to www.support.getzooz.com for detailed instructions on how to change the settings on Z-Box, SmartThings, Hubitat, Home Assistant, and more. Or just email us: ask@getzooz.com

ASSOCIATION

This device supports Group 1 with up to 1 devices for Lifeline communication and Groups 2 (for Relay 1) and 3 (for R2) with up to 5 devices each to send BASIC_SET reports when operated manually.

On Off Status After Power Failure

Parameter 1: Set the on off status for the relays after power failure.

Values: 0 – ALL relays forced to OFF (regardless of state prior to power outage); 1 – ALL relays remember and restore on/off status after power failure (default); 2 – ALL relays forced to ON (regardless of state prior to power outage); 3 – Relay 1 remembers and restores on/off status after power failure, Relay 2 forced to ON; 4 – Relay 2 remembers and restores on/off status after power failure, Relay 1 forced to ON.
Size: 1 byte dec.

Input Type for Relay 1 (S1)

Parameter 2: Choose the wall switch or input type you want to connect to the S1 C terminals.

Values: 0 – momentary for lights only; 1 – toggle switch (light on when the switch is toggled up, light off when the switch is toggled down); 2 – toggle switch (state changes whenever the switch is toggled); 3 – garage door (momentary mode for Z-Wave control); 4 – leak alarm (water sensor); 5 – heat alarm; 6 – motion alert; 7 – open/close alert (door sensor); 8 – CO alarm; 9 – CO2 alarm; 10 – on/off report (dry contact switch/sensor). 11 – garage door mode with wired sensor. Default: 2.
Press and hold the Z-Wave button for 5 seconds to change to garage mode manually.

IMPORTANT: If you set this parameter to value 4-10, you'll need to exclude and re-include the device (without changing any settings) so that a child device is created for the input of your choice!

Size: 1 byte dec.

Input Type for Relay 2 (S2)

Parameter 3: Choose the wall switch or input type you want to connect to the S2 C terminals.

Values: 0 – momentary for lights only; 1 – toggle switch (light on when the switch is toggled up, light off when the switch is toggled down); 2 – toggle switch (state changes whenever the switch is toggled); 3 – garage door (momentary mode for Z-Wave control); 4 – leak alarm (water sensor); 5 – heat alarm; 6 – motion alert; 7 – open/close alert (door sensor); 8 – CO alarm; 9 – CO2 alarm; 10 – on/off report (dry contact switch/sensor). 11 – garage door mode with wired sensor. Default: 2.
Press and hold the Z-Wave button for 5 seconds to change to garage mode manually.

IMPORTANT: If you set this parameter to value 4-10, you'll need to exclude and re-include the device (without changing any settings) so that a child device is created for the input of your choice!

Size: 1 byte dec.

LED Indicator Control

Parameter 5: Choose if you want the LED indicator to turn on when any of the relays are on or if all of them are off, or if you want it to remain on or off at all times.

Values: 0 – LED indicator is on when ALL of the relays are off, LED indicator is off when any of the relays is on (default); 1 – LED indicator is on when any of the relays is on, LED indicator is off when ALL of the relays are off; 2 – LED indicator is always OFF; 3 – LED indicator is always ON.

Click the Z-Wave button 5 times quickly to change mode manually.

Size: 1 byte dec.

Auto Turn-Off Timer for Relay 1

Parameter 6: Use this parameter to set the time after which you want the device connected to Relay 1 to automatically turn off once it has been turned on. The number entered as value corresponds to the number of minutes, seconds, or hours (set the unit in Par. 15).

Values: 0 – timer disabled (default); 1 – 65535.
Size: 4 byte dec.

Auto Turn-On Timer for Relay 1

Parameter 7: Use this parameter to set the time after which you want the device connected to Relay 1 to automatically turn on once it has been turned off. The number entered as value corresponds to the number of minutes, seconds, or hours (set the unit in Par. 16).

Values: 0 – timer disabled (default); 1 – 65535.
Size: 4 byte dec.

Auto Turn-Off Timer for Relay 2

Parameter 8: Use this parameter to set the time after which you want the device connected to Relay 2 to automatically turn off once it has been turned on. The number entered as value corresponds to the number of minutes, seconds, or hours (set the unit in Par. 17).

Values: 0 – timer disabled (default); 1 – 65535.
Size: 4 byte dec.

Auto Turn-On Timer for Relay 2

Parameter 9: Use this parameter to set the time after which you want the device connected to Relay 2 to automatically turn on once it has been turned off. The number entered as value corresponds to the number of minutes, seconds, or hours (set the unit in Par. 18).

Values: 0 – timer disabled (default); 1 – 65535.
Size: 4 byte dec.

Input Trigger for Relay 1

Parameter 10: Choose if you'd like the connected input (switch) on S1 C / VC C to trigger the load connected to R1 or if you want to use the input reports for monitoring only and separate the output from the input.

Values: 0 – input trigger disabled; 1 – input trigger enabled (default).
Size: 1 byte dec.

Input Trigger for Relay 2

Parameter 11: Choose if you'd like the connected input (switch) on S2 C / VC C to trigger the load connected to R2 or if you want to use the input reports for monitoring only and separate the output from the input.

Values: 0 – input trigger disabled; 1 – input trigger enabled (default).
Size: 1 byte dec.

Auto Turn-Off Timer Unit for Relay 1

Parameter 15: Choose between seconds, minutes, and hours as the unit for the auto turn-off timer for Relay 1.

Values: 0 – minutes (default); 1 – seconds; 2 – hours.
Size: 1 byte dec.

Auto Turn-On Timer Unit for Relay 1

Parameter 16: Choose between seconds, minutes, and hours as the unit for the auto turn-on timer for Relay 1.

Values: 0 – minutes (default); 1 – seconds; 2 – hours.
Size: 1 byte dec.

Auto Turn-Off Timer Unit for Relay 2

Parameter 17: Choose between seconds, minutes, and hours as the unit for the auto turn-off timer for Relay 2.

Values: 0 – minutes (default); 1 – seconds; 2 – hours.
Size: 1 byte dec.

Auto Turn-On Timer Unit for Relay 2

Parameter 18: Choose between seconds, minutes, and hours as the unit for the auto turn-on timer for Relay 2.

Values: 0 – minutes (default); 1 – seconds; 2 – hours.
Size: 1 byte dec.

DC Motor Mode

Parameter 24: Sync R1 and R2 together to prevent them from being activated at the same time.

Values: 0 – DC motor mode disabled (relays will activate whenever they're triggered); 1 – DC motor mode enabled (relay will check the status of the other relay after being triggered and will shut the other relay off before activating so that only one of the relays is on at the same time). Default: 0.
Size: 1 byte dec.

More settings at www.support.getzooz.com

WARRANTY

This product is covered under a 12-month warranty and under a 5-year limited warranty once registered. To read the full warranty policy or file a warranty claim, please go to www.getzooz.com/warranty

IN NO EVENT SHALL ZOOZ OR ITS SUBSIDIARIES AND AFFILIATES BE LIABLE FOR ANY INDIRECT, INCIDENTAL, PUNITIVE, SPECIAL, OR CONSEQUENTIAL DAMAGES, OR DAMAGES FOR LOSS OF PROFITS, REVENUE, OR USE INCURRED BY CUSTOMER OR ANY THIRD PARTY, WHETHER IN AN ACTION IN CONTRACT, OR OTHERWISE EVEN IF ADVISED OF THE POSSIBILITY OF SUCH DAMAGES. ZOOZ'S LIABILITY AND CUSTOMER'S EXCLUSIVE REMEDY FOR ANY CAUSE OF ACTION ARISING IN CONNECTION WITH THIS AGREEMENT OR THE SALE OR USE OF THE PRODUCTS, WHETHER BASED ON NEGLIGENCE, STRICT LIABILITY, BREACH OF WARRANTY, BREACH OF AGREEMENT, OR EQUITABLE PRINCIPLES, IS EXPRESSLY LIMITED TO, AT ZOOZ'S OPTION, REPLACEMENT OF, OR REPAYMENT OF THE PURCHASE PRICE FOR THAT PORTION OF PRODUCTS WITH RESPECT TO WHICH DAMAGES ARE CLAIMED. ALL CLAIMS OF ANY KIND ARISING IN CONNECTION WITH THIS AGREEMENT OR THE SALE OR USE OF PRODUCTS SHALL BE DEEMED WAIVED UNLESS MADE IN WRITING WITHIN THIRTY (30) DAYS FROM ZOOZ'S DELIVERY, OR THE DATE FIXED FOR DELIVERY IN THE EVENT OF NONDELIVERY.

FCC Caution

This device complies with part 15 of the FCC Rules. Operation is subject to the following two conditions: (1) This device may not cause harmful interference, and (2) this device must accept any interference received, including interference that may cause undesired operation. Any Changes or modifications not expressly approved by the party responsible for compliance could void the user's authority to operate the equipment.

Note: This equipment has been tested and found to comply with the limits for a Class B digital device, pursuant to part 15 of the FCC Rules. These limits are designed to provide reasonable protection against harmful interference in a residential installation. This equipment generates uses and can radiate radio frequency energy and, if not installed and used in accordance with the instructions, may cause harmful interference to radio communications. However, there is no guarantee that interference will not occur in a particular installation. If this equipment does cause harmful interference to radio or television reception, which can be determined by turning the equipment off and on, the user is encouraged to try to correct the interference by one or more of the following measures:

- Reorient or relocate the receiving antenna.
- Increase the separation between the equipment and receiver.
- Connect the equipment into an outlet on a circuit different from that to which the receiver is connected.
- Consult the dealer or an experienced radio/TV technician for help.

This equipment complies with FCC radiation exposure limits set forth for an uncontrolled environment. This equipment should be installed and operated with minimum distance 20cm between the radiator & your body.