

User Manual

Product Name :	Motion Sensor
Model NO :	ZSE18 800LR

Directory

一、 Product General Description	2
1.1 Product Picture.....	2
1.2 Product Introductions.....	3
二、 Product Feature	4
2.1 Product Electrical Specification.....	4
2.2 Definition of button and indicator light	5
2.2.1 Keypad Function Description	5
2.2.2 Button definition.....	6
2.2.3 Indicator light definition	6
三、 Reference To Standard	7
四、 Environment Condition	7
五、 Electrical Characteristics.....	8
5.1 Basic Characteristic	8
5.2 PIR Characteristic	8
5.3 Wireless Characteristic	9
六、 Z-Wave Software Function Description	10
6.1 Z-Wave Plus device type	10
6.2 Command list.....	10
6.3 Command description.....	11
6.3.1 Z-Wave Plus Info Report Command.....	11
6.3.2 Association command	11
6.3.3 Manufacturer Specific Report command.....	11
6.3.4 Version Report command.....	12
6.3.5 Notification command	12
6.3.6 Wake Up command.....	13
6.3.7 Battery command.....	13
6.4 Configuration command	14

一、 Product General Description

1.1 Product Picture

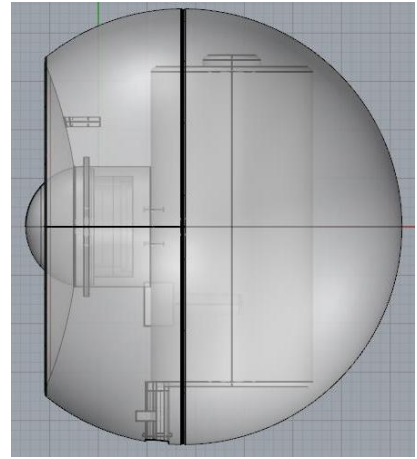
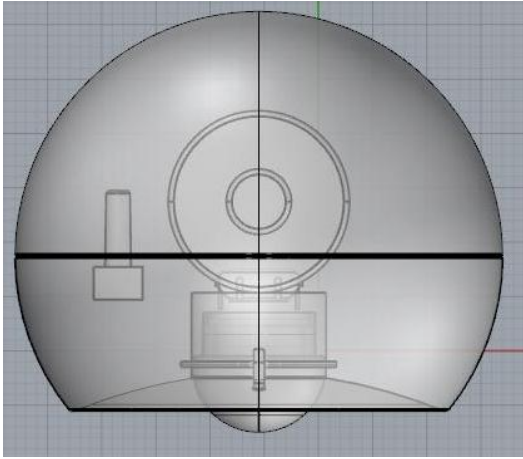

1.2 Product Introductions

This product is an intelligent sensor developed based on Z-Wave, which can be used for illegal intrusion detection in unmanned areas. It is suitable for most regions in Europe and America. The main functional features are as follows:

- Remote monitoring of human activity and reporting of alarm information through the Z-Wave system;
- As a standard Z-wave device, this product supports the Z-Wave Plus protocol and can work in our company's Z-Wave gateway or third-party gateway that supports Z-Wave Plus;
- Support Z-wave long range, with wider wireless coverage, scalable network node characteristics, and lower power consumption;
- Support LED indication of working status: inclusion, exclusion etc;
- 1 CR123A battery (nominal 3V) or USB powered;
- Ultra low standby power consumption, which can be used for a long time;
- Equipped with tamper detection function;
- Strong magnetic suction bracket that can rotate to achieve multi angle detection;
- Support OTA upgrade;
- Z-wave 800 series chip (ZG23A020)
- Compliance with CE, FCC, and ROHS;

二、 Product Feature

2.1 Product Electrical Specification

Function	Description
Inclusion	When the product is outside of network, if the controller is adding the device, and the product enters into learning mode (sending Node Info), then the product will be added to the controller's network.
Exclusion	When the product is inside of network, and a controller is at adding devices Mode, and the product is at learning mode (sending Node info), the product will be removed in the controller network.
Wake Up	<ol style="list-style-type: none"> 1. The product will enter the sleep mode in the free time. 2. Short press the button once, the product will send 'Wake up notification CC' 3. When receive "Wake up no more information CC", the product will enter the sleep mode.
Setting for the Sleep and Wake cycle	<ol style="list-style-type: none"> 1. Send "Wake up interval set CC" to the product to configure the sleep and wake cycle of the product. 2. If the configured time is less than 3600 seconds, the device will not automatically wake up. The minimum unit configured by the user is 60 seconds, such as: When the configured time is 3600-3659, the actual wake-up time is 3600 seconds. When the configured time is 3660-3719, the actual wake-up time is 3660 seconds. When the configured time is between 3720 and 3779, the actual wake-up time is 3720 seconds. And so on. 3. The default value is: 3600 seconds
Report PIR motion	<ol style="list-style-type: none"> 1. PIR opening, closing and sensitivity configuration (configuration parameter 12). 2. When PIR is triggered, the product will send Basic Set (0xff) to the nodes that associated with group 2 (configuration parameter 14). 3. When PIR is untriggered, the product will send Basic Set (0x00) to the nodes that associated with group 2 (configuration parameter 16).
Report battery power	<ol style="list-style-type: none"> 1. The current battery charge will be automatically reported after the power back on. 2. The current battery power will be reported after the success inclusion of the product. 3. Report the battery power regularly.
Report low battery	When the battery level drops below the set minimum value, an alarm will sound (configurable by parameter 32)
Report Tamper	When the tamper is triggered, a report will be sent to the controller, the Notification Report Event= Tampering product covering removed (03); When the tamper is untriggered, after 3seconds, a cleaning event report will be sent.
OTA	Firmware can be upgraded through the z-wave network.
Factory data reset	Restore all configuration to default values and exclude the device to the network.

2.2 Definition of button and indicator light

2.2.1 Keypad Function Description

Trigger mode	Network state	LED	Function description
Start	In the network	Power on: light on for 3 seconds, then off	--
	Outside the network	Power on: flashing slowly 3 times	Enter “SmartStart” function; The indicator will be off after the success of inclusion
Short press 1 time	In the network	Flash 1 time	Wake up device
	Outside the network	LED keep quick flashing and enter learning mode; 1) it will flash slowly 2 times when 30s timeout Or inclusion failed; 2) When inclusion successes, the LED will be solid on for 2S then off.	Enter “learn” function. Sending node info. The LED indicator will be solid on for 2S and then off after the inclusion.
Triple click	Outside the network	LED keep quick flashing and enter learning mode; 1) it will flash slowly 2 times when 30s timeout Or inclusion failed; 2) When inclusion successes, the LED will be solid on for 2S then off.	Enter “learn” function. Sending node info. The LED indicator will be solid on for 2S and then off after the inclusion.
	In the network	LED keep quick flashing and enter learning mode; 1) it will flash slowly 2 times when 30s timeout Or exclusion failed; 2) When exclusion successes, the LED will be solid on for 2S then off.	Enter “learn” function. Sending node info. The LED indicator will be solid on for 2S and then off after the exclusion.
Long press	In the network	1~3s,on	--
		3~10S, flashing quickly	long press the button till the LED flashing quickly , it will send “wake up notification” And then LED indicator will be off after receive” wake up no more information”
		>=20S , solid on	Restore to factory Settings, sending “Device Reset locally” to notify the controller.
Tamper/motion triggered	In the network	Flash 1 time	--
sleep	In the network	Be off	--

2.2.2 Button definition

Definition of actions	Action time interval (seconds)
Short press	< 1s
Long press	>=1s

2.2.3 Indicator light definition

Flashing way	definition
Slow flash	Blink every 2S.
Quick flash	Blink every 0.5 seconds.

三、 Reference To Standard

FCC, CE,ROHS

四、 Environment Condition

NO	Items	Parameter	Unit	Remark
1	Operating Temperature	-10~+40	°C	
2	Storage Temperature	-20~+60	°C	
3	Relative Humidity	8~80	%RH	

五、Electrical Characteristics

5.1 Basic Characteristic

NO	Items	Parameter			Remark
		Min.	Typ.	Max.	
1	Input voltage range	2.0V	--	3V	
2	Standby Current	--	6mA	10mA	
3	Standby Current	--	40uA	80uA	
4	Default Power	--	CR123A*1 / USB	--	
5	Default Battery Capacity	--	1300mAh	--	

5.2 PIR Characteristic

NO	Items	Parameter			Remark
		Min.	Typ.	Max.	
1	Detection Distance	6m	8m	10m	
2	Detection Angle	--	--	120°	
3	Sensitivity Level	1	8	8	

5.3 Wireless Characteristic

NO	Items Types	Parameter			Remark
		Min.	Typ.	Max.	
1	Frequency range	1)908.4MHz 2)912.0MHz	--	916.0MHz 920.0MHz	US
2	Indoor communication distance	30M	--	--	
3	Outdoor communication distance	100M	--	--	

六、Z-Wave Software Function Description

SDK:7.18.4

6.1 Z-Wave Plus device type

Device Type	Basic device feature	Specific device feature	Role Type
Sensor - Notification	GENERIC_TYPE_SENSOR_NOTIFICATION	SPECIFIC_TYPE_NOTIFICATION_SENSOR	Reporting Sleeping Slave (RSS)

6.2 Command list

Command	Version	Security type
COMMAND_CLASS_ZWAVEPLUS_INFO_V2	2	None
COMMAND_CLASS_TRANSPORT_SERVICE_V2	2	None
COMMAND_CLASS_SECURITY_2_V1	1	None
COMMAND_CLASS_SUPERVISION_V1	1	None
COMMAND_CLASS_APPLICATION_STATUS_V1	1	None
COMMAND_CLASS_BASIC	3	S0/S2 Authenticated/Unauthenticated
COMMAND_CLASS_NOTIFICATION_V8	8	S0/S2 Authenticated/Unauthenticated
COMMAND_CLASS_BATTERY_V1	1	S0/S2 Authenticated/Unauthenticated
COMMAND_CLASS_WAKE_UP_V2	2	S0/S2 Authenticated/Unauthenticated
COMMAND_CLASS_CONFIGURATION_V4	4	S0/S2 Authenticated/Unauthenticated
COMMAND_CLASS_ASSOCIATION_V2	2	S0/S2 Authenticated/Unauthenticated
COMMAND_CLASS_ASSOCIATION_GRP_INFO_V1	3	S0/S2 Authenticated/Unauthenticated
COMMAND_CLASS_VERSION_V2	3	S0/S2 Authenticated/Unauthenticated
COMMAND_CLASS_MANUFACTURER_SPECIFIC_V2	2	S0/S2 Authenticated/Unauthenticated
COMMAND_CLASS_DEVICE_RESET_LOCALLY_V1	1	S0/S2 Authenticated/Unauthenticated
COMMAND_CLASS_POWERLEVEL_V1	1	S0/S2 Authenticated/Unauthenticated
COMMAND_CLASS_FIRMWARE_UPDATE_MD_V5	5	S0/S2 Authenticated/Unauthenticated
COMMAND_CLASS_MULTI_CHANNEL_ASSOCIATION_V3	3	S0/S2 Authenticated/Unauthenticated
COMMAND_CLASS_INDICATOR_V3	3	S0/S2 Authenticated/Unauthenticated

6.3 Command description

6.3.1 Z-Wave Plus Info Report Command

Parameter	Value
Z-Wave Plus Version	2
Role Type	6 (ROLE_TYPE_SLAVE_SLEEPING_REPORTING)
Node Type	0 (ZWAVEPLUS_INFO_REPORT_NODE_TYPE_ZWAVEPLUS_NODE)
Installer Icon Type	0x0C07 (ICON_TYPE_SPECIFIC_SENSOR_NOTIFICATION_HOME_SECURITY)
User Icon Type	0x0C07 (ICON_TYPE_SPECIFIC_SENSOR_NOTIFICATION_HOME_SECURITY)

6.3.2 Association command

Support two groups of associated nodes, each with a maximum of five node Numbers.

Group ID	Support Node	Support commands
Group 1(Lifeline)	5	<p>1. Notification Report. The Notification Report command is used when a supported notification event is triggered</p> <p>2. Battery Report. A Battery Report is sent when the device is powered on, successfully networked or periodically.</p> <p>3. Device Reset Locally Notification. It sends a Device Reset Locally Notification when you hold down the button for longer than 20s and release it</p> <p>4. Indicator Report.</p>
Group 2(On/Off control)	5	<p>1. Basic Set The Basic Set is sent when the PIR is triggered or untriggered, which can be configured with parameters 14 and 16</p>

6.3.3 Manufacturer Specific Report command

Par	Value(Hex)
Manufacturer ID 1	0x02
Manufacturer ID 2	0x7A
Product Type ID 1	0x03
Product Type ID 2	0x01(US)
Product ID 1	0x00
Product ID 2	0x12

6.3.4 Version Report command

Parameter	Value (HEX)
Z-Wave Protocol Library Type	0x03
Z-Wave Protocol Version	0x07
Z-Wave Protocol Sub Version	0x13
Firmware 0 Version	Firmware 0 version
Firmware 0 Sub Version	Firmware 0 Sub Version
Hardware Version	0x01
Number of Firmware Targets	0x00

6.3.5 Notification command

Notification type	Notification Event	Description
Home Security (0x07)	(0x00) State idle	Notification value for the state variable going to idle.
	(0x08) Motion detection	When motion triggered.
	(0x03) Tampering, product moved	When vibrating.
Power Management (0x08)	(0x02)AC mains disconnected	When USB disconnected and insert battery again.
	(0x03) AC mains re-connected	When insert the USB cable. TIP: When powered by USB, the device will work as a repeater.

When PIR is triggered, send Motion Detection Unknown Location (08);

When PIR detection is cleared, send Previous Events cleared (00),Parameter 1 is Motion Detection Unknown Location (08) ;

When Tamper/motion is detected, send Tampering Product covering removed (03);

The report that Event is cleared will be sent after 2.5s, Previous Events cleared (00), and Parameter 1 is Tampering Product covering removed (03);

6.3.6 Wake Up command

(1) When the device is included, short press Z-Wave button one time, after release, it will send Wake Up Notification

(2) Use command “wake up interval set” to configure the interval time of wake up. If the configured time is less than 3600 seconds, the device will not automatically wake up. The minimum unit configured by the user is 60 seconds, such as:

When the configured time is 3600-3659, the actual wake-up time is 3600 seconds.

When the configured time is 3660-3719, the actual wake-up time is 3660 seconds.

When the configured time is between 3720 and 3779, the actual wake-up time is 3720 seconds. And so on.

(3) Wake Up Interval Capabilities Report CC

Minimum Wake Up Interval Seconds = 3600s

Maximum Wake Up Interval Seconds = 3600x24, equal to 24h

Default Wake Up Interval Seconds = 14400 seconds (4 hours)

Wake Up Interval Step Seconds = 3600 S

6.3.7 Battery command

(1) Send ”battery get” command to the device, Report the current battery power when it wakes up. It report 100% power level when the power is up to 3V. 0% when the power is 2.0V.

(2) When the device is low voltage, (Par 32 can Configure the threshold, The default value is less than 20%) , Report to the group 1 associated node “Battery report 0xff”.

6.4 Configuration command

Par	Bytes	Default value	Descriptions
12	1	8	PIR Sensitivity configuration 0 — turn off PIR notification 1~8 — turn on PIR notification, Corresponding to PIR sensitivity, there are 8 levels, 1 indicates the lowest sensitivity and 8 indicates the highest sensitivity.
14	1	0	When the PIR is triggered, whether to send the Basic Set command. 0 — Not send 1 — Send Basic Set command.
15	1	0	When the PIR is triggered, the way of sending Basic Set command: 0 — When PIR is triggered, send Basic Set 0xFF; When PIR is cleared, send Basic Set 0x00. 1 — When PIR is triggered, send Basic Set 0x00; When PIR is cleared, send Basic Set 0xFF.
16	1	0	When the PIR is untriggered, whether to send the Basic Set command. 0 — Not send 1 — Send Basic Set command.
17	1	0	Enable/Disable Tamper detection: 0 — Disable 1 — Enable
18	2	30	(1) Wait time for clearing the PIR triggered (default 30 seconds) If there is no trigger during this time, it will send Notification (Notification Type is Home Security, Event is 0, Parameter 1 is Motion Detection Unknown Location) to its associated node. (2) effective value: 10~3600 s
19	1	1	Whether to send the Binary Sensor Report. 0=Not send Binary Sensor Report, only send notification 1=Only send Binary Sensor Report, not send notification Tip: The Z-Wave 800 series has abandoned the Sensor Binary and is not recommended for further use.

20	1	1	<p>Enable or disable LED indicator for motion alerts.</p> <p>0 – don't flash LED when motion is detected 1 – flash LED indicator when motion is detected.</p> <p>TIP: Click the button 6 times quickly to change the LED indicator mode manually.</p>
32	1	20	<p>Threshold value to enable battery power report when the battery is changed value exceeds the value. effective value: 10~50%;</p>
254	1	0	<p>The Configuration function is locked, and after locking, except for this parameter, the values of other parameters cannot be changed:</p> <p>0 – Unlock。 1 – Lock。</p>

Warning: Changes or modifications to this unit not expressly approved by the party responsible for compliance could void the user's authority to operate the equipment.

NOTE: This device complies with part 15 of the FCC Rules. Operation is subject to the following two conditions: (1) This device may not cause harmful interference, and (2) this device must accept any interference received, including interference that may cause undesired operation.

FCC Statement: This equipment has been tested and found to comply with the limits for a Class B digital device, pursuant to part 15 of the FCC Rules. These limits are designed to provide reasonable protection against harmful interference in a residential installation. This equipment generates, uses and can radiate radio frequency energy and, if not installed and used in accordance with the instructions, may cause harmful interference to radio communications. However, there is no guarantee that interference will not occur in a particular installation. If this equipment does cause harmful interference to radio or television reception, which can be determined by turning the equipment off and on, the user is encouraged to try to correct the interference by one or more of the following measures:

- Reorient or relocate the receiving antenna.
- Increase the separation between the equipment and receiver.
- Connect the equipment into an outlet on a circuit different from that to which the receiver is connected.
- Consult the dealer or an experienced radio/TV technician for help.

The equipment complies with FCC Radiation exposure limit set forth for uncontrolled environment. This equipment should be installed and operated with minimum distance 20cm between the radiator and your body.