



Prüfbericht-Nr.: <i>Test report no.:</i>	CN21KX7T 002	Auftrags-Nr.: <i>Order no.:</i>	168326740	Seite 1 von 23 <i>Page 1 of 23</i>
Kunden-Referenz-Nr.: <i>Client reference no.:</i>	N/A	Auftragsdatum: <i>Order date:</i>	2021-07-12	
Auftraggeber: <i>Client:</i>	Luxshare Precision Industry Co., Ltd. Floor 2, Block A, Sanyo New Industrial Area, West Haoyi Community, Shajing Subdistrict Office, Bao'an District, Shenzhen, P. R. China			
Prüfgegenstand: <i>Test item:</i>	ZENS Fast Dual Wireless Charger			
Bezeichnung / Typ-Nr.: <i>Identification / Type no.:</i>	ZENDC05B/00, ZENDC05W/00 (Trademark: zens)			
Auftrags-Inhalt: <i>Order content:</i>	Type test			
Prüfgrundlage: <i>Test specification:</i>	CFR47 FCC Part 15: Subpart C Section 15.207 CFR47 FCC Part 15: Subpart C Section 15.209 CFR47 FCC Part 15: Subpart C Section 15.215 CFR47 FCC Part 2: Subpart J Section 1.1310			
Wareneingangsdatum: <i>Date of sample receipt:</i>	2021-07-12	Refer to photos document		
Prüfmuster-Nr.: <i>Test sample no.:</i>	A003088752-001~004			
Prüfzeitraum: <i>Testing period:</i>	2021-07-13 – 2021-07-30			
Ort der Prüfung: <i>Place of testing:</i>	TÜV Rheinland (Shenzhen) Co., Ltd.			
Prüflaboratorium: <i>Testing laboratory:</i>	TÜV Rheinland (Shenzhen) Co., Ltd.			
Prüfergebnis*: <i>Test result*:</i>	Pass			
geprüft von: <i>tested by:</i>		genehmigt von: <i>authorized by:</i>		
Datum: <i>Date:</i> 2021-09-01	<small>Signed by: Alex Lan</small>	Ausstellungsdatum: <i>Issue date:</i> 2021-09-01	<small>Signed by: Winnie Hou</small>	
Stellung / Position	Senior Project Engineer	Stellung / Position	Department Manager	
Sonstiges / Other:	This test report is for apple watch charger part. FCC ID: 2AYYSZEDC05			
Zustand des Prüfgegenstandes bei Anlieferung: <i>Condition of the test item at delivery:</i>	Prüfmuster vollständig und unbeschädigt <i>Test item complete and undamaged:</i>			
* Legende: 1 = sehr gut P(ass) = entspricht o.g. Prüfgrundlage(n)	2 = gut 2 = good	3 = befriedigend 3 = satisfactory F(ail) = entspricht nicht o.g. Prüfgrundlage(n)	4 = ausreichend 4 = sufficient N/A = nicht anwendbar N/A = not applicable	5 = mangelhaft N/T = nicht getestet 5 = poor N/T = not tested
Legend: 1 = very good P(ass) = passed a.m. test specifications(s)	2 = good	3 = satisfactory F(ail) = failed a.m. test specifications(s)	4 = sufficient N/A = not applicable	5 = poor N/T = not tested
Dieser Prüfbericht bezieht sich nur auf das o.g. Prüfmuster und darf ohne Genehmigung der Prüfstelle nicht auszugsweise vervielfältigt werden. Dieser Bericht berechtigt nicht zur Verwendung eines Prüfzeichens. <i>This test report only relates to the a. m. test sample. Without permission of the test center this test report is not permitted to be duplicated in extracts. This test report does not entitle to carry any test mark.</i>				

V05

Test Summary

5.1.1 ANTENNA REQUIREMENT

RESULT: Pass

5.1.2 20dB BANDWIDTH

RESULT: Pass

5.1.3 RADIATED SPURIOUS EMISSION

RESULT: Pass

5.1.4 CONDUCTED EMISSIONS

RESULT: Pass

Contents

1	GENERAL REMARKS	4
1.1	COMPLEMENTARY MATERIALS	4
2	TEST SITES.....	4
2.1	TEST FACILITIES.....	4
2.2	LIST OF TEST AND MEASUREMENT INSTRUMENTS	5
2.3	TRACEABILITY.....	7
2.4	CALIBRATION.....	7
2.5	MEASUREMENT UNCERTAINTY	7
2.6	LOCATION OF ORIGINAL DATA	7
2.7	STATUS OF FACILITY USED FOR TESTING.....	7
3	GENERAL PRODUCT INFORMATION.....	8
3.1	PRODUCT FUNCTION AND INTENDED USE.....	8
3.2	RATINGS AND SYSTEM DETAILS	8
3.3	INDEPENDENT OPERATION MODES	9
3.4	NOISE GENERATING AND NOISE SUPPRESSING PARTS.....	9
3.5	SUBMITTED DOCUMENTS.....	9
4	TEST SET-UP AND OPERATION MODES	10
4.1	PRINCIPLE OF CONFIGURATION SELECTION.....	10
4.2	TEST OPERATION AND TEST SOFTWARE.....	10
4.3	SPECIAL ACCESSORIES AND AUXILIARY EQUIPMENT.....	10
4.4	COUNTERMEASURES TO ACHIEVE EMC COMPLIANCE.....	10
4.5	TEST SETUP DIAGRAM	11
5	TEST RESULTS.....	12
5.1	TRANSMITTER REQUIREMENT & TEST SUITES.....	12
5.1.1	<i>Antenna Requirement.....</i>	<i>12</i>
5.1.2	<i>20dB Bandwidth.....</i>	<i>13</i>
5.1.3	<i>Radiated Spurious Emission.....</i>	<i>14</i>
5.1.4	<i>Conducted emissions.....</i>	<i>20</i>
6	PHOTOGRAPHS OF THE TEST SET-UP.....	23
7	LIST OF TABLES	23

1 General Remarks

1.1 Complementary Materials

All attachments are integral parts of this test report. This applies especially to the following appendix:

Appendix A: Photographs of the Test Set-up

2 Test Sites

2.1 Test Facilities

TÜV Rheinland (Shenzhen) Co., Ltd.

No. 362 Huangguan Road Middle, Longhua District, Shenzhen 518110, China

FCC Registration No.: CN1260

IC Registration No.: 25069

2.2 List of Test and Measurement Instruments

Table 1: List of Test and Measurement Equipment

Radio Spectrum Testing				
Description	Manufacturer	Model	Serial No.	Cal. Until
Signal Analyzer	R&S	FSV 40	101441	2021-08-10
OSP	R&S	OSP 150	101017	2021-12-10
Control PC	DELL	OptiPlex 7050	FTJZ9P2	N/A
Test Software	Rohde & Schwarz	WMS32 (V10.40.10)	N/A	N/A
Shielding Room 8#	Albatross	SR8	APC17151-SR8	2022-06-22
Unwanted Emission Testing				
Description	Manufacturer	Model	Serial No.	Cal. Until
EMI Test Receiver	R&S	ESR 7	102021	2021-08-11
Signal Analyzer	R&S	FSV 40	101439	2021-08-10
System Controller Interface	Rohde & Schwarz	SCI-100	S10010038	N/A
Filterbank	Rohde & Schwarz	Wlan	100759	2021-08-21
OSP	Rohde & Schwarz	OSP 120	102040	N/A
Pre-amplifier	R&S	SCU08F1	08320031	2021-08-10
Amplifier	R&S	SCU-18F	180070	2021-08-10
Amplifier	R&S	SCU40A	100475	2021-09-10
Trilog Broadband Antenna (30 MHz - 7 GHz)	Schwarzbeck	VULB 9162	193	2022-08-08
Double-Ridged Antenna (1 -18 GHz)	ETS-LINDGREN	3117	00218717	2022-08-08
Wideband Ridged Horn Antenna (18-40 GHz)	Steatite	QMS-00880	19067	2022-08-08
Active Loop Antenna	Schwarzbeck	FMZB 1513	302	2022-09-13
Wideband Ridged Horn Antenna (12-18 GHz)	Steatite	QMS-00208	18313	2021-09-02
Test software	R&S	EMC32 (V10.60.10)	N/A	N/A
Control PC	Dell	OptiPlex 7050	36NV9P2	N/A
3m Semi-Anechoic Chamber	Albatross	SAC-3m	APC17151-SAC	2022-07-01
Conducted Emission				
Description	Manufacturer	Model	Serial No.	Cal. Until
EMI Test Receiver	R&S	ESR3	102680	2022-04-24
Artificial Mains Network	R&S	ENV216	101445	2022-04-24

Prüfbericht - Nr.: CN21KX7T 002
Test Report No.:Seite 6 von 23
Page 6 of 23

EMC32 test software	R&S	EMC32(Ver.10.50.00)	N/A	N/A
---------------------	-----	---------------------	-----	-----

RF Exposure				
Description	Manufacturer	Model	Serial No.	Cal. Until
"Van der Hoofden" test head	Schwarzbeck	VDHH 9502	159	2021-08-17
EMF Tester	NARDA	ELT-400	D-0009/D-0010	2022-01-15

2.3 Traceability

All measurement equipment calibrations are traceable to NIM (National Institute of Metrology) or where calibration is performed in other countries, to equivalent nationally recognized standards organizations.

2.4 Calibration

Equipment requiring calibration is calibrated periodically by the manufacturer or according to manufacturer's specifications. Additionally all equipment is verified for proper performance on a regular basis using in house standards or comparisons.

2.5 Measurement Uncertainty

The estimated combined standard uncertainty for radiated emissions and conducted emissions measurements as below table

Parameter	Uncertainty
Radiated Emission of Transmitter, valid up to 26.5 GHz	±6 dB
Radiated Emission of Receiver, valid up to 26.5 GHz	±6 dB
Conducted Emission, (9kHz to 150kHz)/(150kHz to 30MHz)	±3.70 dB / ±3.30 dB

2.6 Location of Original Data

The original copies of all test data taken during actual testing were attached at Appendix A of this report and delivered to the applicant. A copy has been retained in the TÜV Rheinland (Shenzhen) Co., Ltd. file for certification follow-up purposes.

2.7 Status of Facility Used for Testing

The TÜV Rheinland (Shenzhen) Co., Ltd. Test facility located at No. 362 Huangguan Road Middle, Longhua District, Shenzhen 518110, China is listed on the US Federal Communications Commission list of facilities approved to perform measurements.

3 General Product Information

3.1 Product Function and Intended Use

The devices are a ZENS Fast Dual Wireless Charger, it have two Charging base and one Apple watch charger. The two Charging base are identical in circuit & PCB layout.

The EUT has two different color of enclosure: black for model ZENDC05B/00 and white for model ZENDC05W/00, they are identical in circuit & PCB layout, only the color and model name are difference.

For details refer to the User Manual, Technical Description and Circuit Diagram.

3.2 Ratings and System Details

Table 2: Technical Specification of EUT

General Information of EUT	Value
Kind of Equipment	ZENS Fast Dual Wireless Charger
Type Designation	ZENDC05B/00, ZENDC05W/00
Trade Mark	zens
FCC ID	2AYYSZEDC05
Input Voltage	DC 12V, 2.0A via external AC/DC Adapter
Test Voltage	AC 120V, 60Hz
Technical Specification of WPT (Charging base)	
Operating Frequency	111-205KHz
Extreme Temperature Range	-20°C - +45°C
Modulation	FSK
Antenna Type	Induction coil Antenna
Antenna Gain	0 dBi
Wireless output	10W maximum for each
Technical Specification of WPT (Apple watch charger)	
Operating Frequency	326.5KHz
Modulation	FSK
Antenna Type	Induction coil Antenna
Antenna number	1
Wireless output	Max. 5W

3.3 Independent Operation Modes

The basic operation modes are:

- A. On, Wireless charging
- B. On (10W * 2 + Apple watch)
- C. Off

3.4 Noise Generating and Noise Suppressing Parts

Refer to Circuit Diagram for further details.

3.5 Submitted Documents

- Block Diagram
- Schematics
- User Manual
- Parts List
- Rating Label

4 Test Set-up and Operation Modes

4.1 Principle of Configuration Selection

Emission: The equipment under test (EUT) was configured to measure its highest possible radiation level. The test modes were adapted accordingly in reference to the instructions for use.

Radio Spectrum: The equipment under test (EUT) was configured at its highest power output in order to measure its highest possible radiation and conducted level. The test modes were adapted accordingly in reference to the instructions for use.

4.2 Test Operation and Test Software

Test operation refers to test setup in chapter 5&6. All testing were performed according to the procedures in ANSI C63.10: 2013.

According to clause 3.1, all test were applied on model ZENDC05B/00.

4.3 Special Accessories and Auxiliary Equipment

Table 3: List of Accessories and Auxiliary Equipment

Description	Manufacturer	Model	S/N or Rating
Apple Watch	Apple	M02G3CH/A	GY6F236QQ1RF
Mobile Phone	HUAWEI	HUAWEI P30 Pro	HVQ0119220000186
Mobile Phone	HUAWEI	HUAWEI Mate20 Pro	016FGT192L000199
AC/DC Adapter	ULLPOWER	ICP30A-120-2000	Input: AC 100-240V, 50/60Hz, 0.8A Output: DC 12V, 2A, 24W

4.4 Countermeasures to Achieve EMC Compliance

The test sample which has been tested contained the noise suppression parts as described in the Technical Construction File (TCF).

No additional measures were employed to achieve compliance.

4.5 Test Setup Diagram

Diagram of Measurement Configuration for Radiation Test (Below 30MHz)

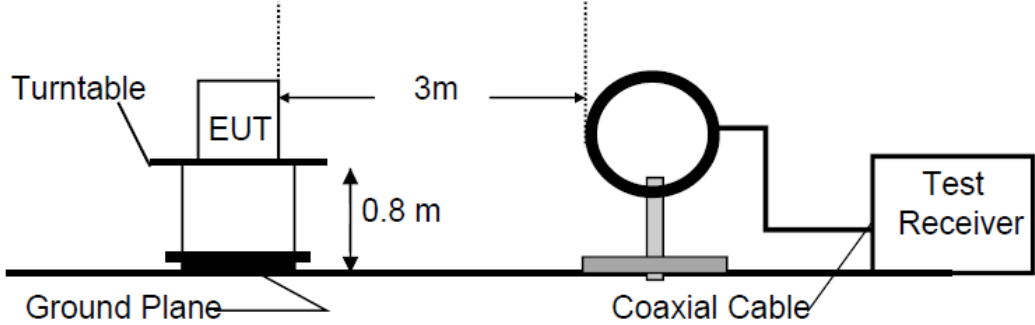

Diagram of Measurement Configuration for Radiation Test (Below 1GHz)

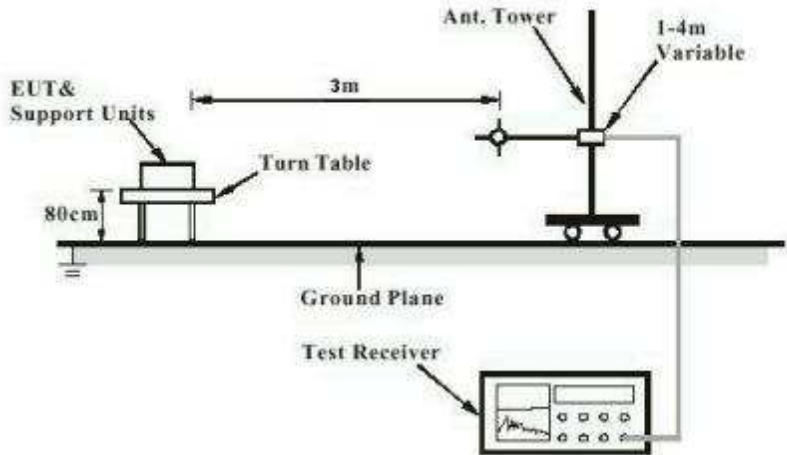
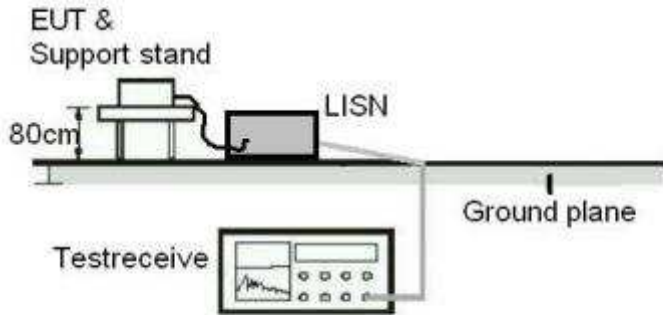

Diagram of Measurement Equipment Configuration for Mains Conduction Measurement



5 Test Results

5.1 Transmitter Requirement & Test Suites

5.1.1 Antenna Requirement

RESULT:

Pass

Test Specification

Test standard : Part 15.203

According to the manufacturer declared, the EUT has an internal antenna, and the antenna is permanent attachment and no consideration of replacement. Therefore the EUT is considered sufficient to comply with the provision.

Refer to EUT Photo for further details.

5.1.2 20dB Bandwidth

RESULT:
Pass
Test Specification

Test standard : FCC Part 15.215(c)
 Basic standard : ANSI C63.10: 2013
 Kind of test site : Shielded Room

Test Setup

Date of testing : 2021-07-30
 Input voltage : 120Vac, 60Hz
 Operation mode : A
 Ambient temperature : 25 °C
 Relative humidity : 56 %
 Atmospheric pressure : 101 kPa

For details refer to following test result.

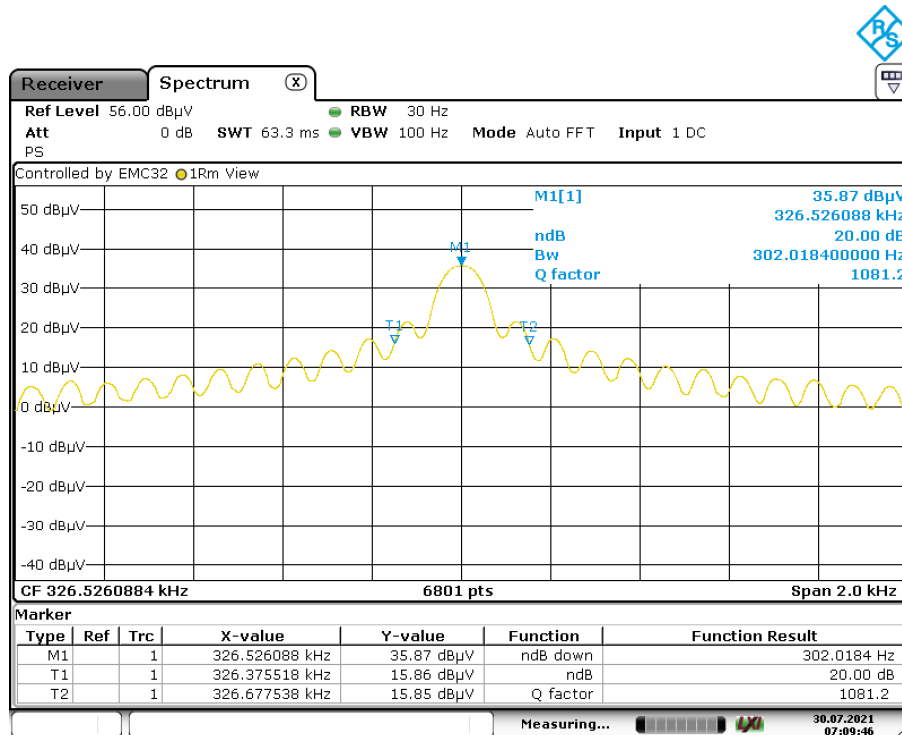

5.1.3 Radiated Spurious Emission

RESULT:**Pass****Test Specification**

Test standard	:	FCC Part 15.209 & 15.205
Basic standard	:	ANSI C63.10: 2013
Limits	:	Refer to 15.209(a)
Kind of test site	:	3m Semi-anechoic Chamber

Test Setup

Date of testing	:	2021-07-15 ~ 2021-07-16
Input voltage	:	120Vac, 60Hz
Operation mode	:	A
Ambient temperature	:	23 °C
Relative humidity	:	51 %
Atmospheric pressure	:	101 kPa

Refer to following test plots for details of test result.

Measurements are to be taken in dBuV/m, corrected, and the end result shall be mathematically converted to the dBuA/m for RSS and presented against the correct limit.

$$E [\text{dB}\mu\text{A/m}] = \text{AF} [\text{dBS/m}] + V [\text{dB}\mu\text{V}] + \text{Cable loss} [\text{dB}]$$

E [dBμA/m] is the magnetic field strength (Final Test results)

AF [dBS/m] is the magnetic antenna factor of the antenna (H-field)

V [dBμV] is the reading level on the spectrum analyzer

Note that when using the AF [dBS/m] the 51.5 dB is already account for into the antenna factor.

EUT Information

EUT Name:	ZENS Fast Dual Wireless Charger
Model:	ZENDC05B/00
Test Mode:	Charging
Test Voltage::	120V/60Hz
Remark:	Temp 23 Humi:51%
Test Standard:	FCC Part 15C
Tested By:	Kei Zhang
Reviewed By:	Terry Yin

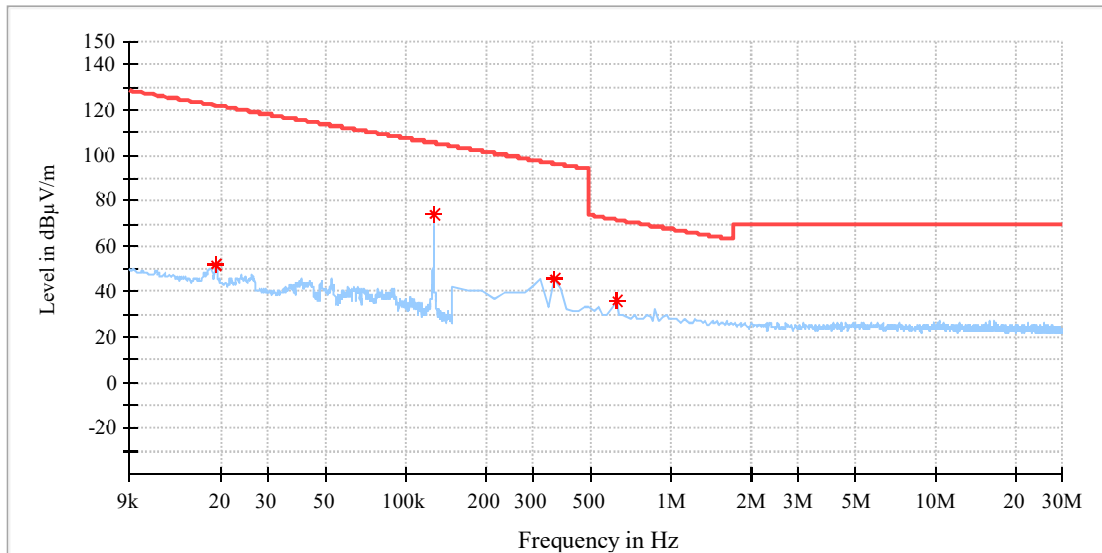

Critical_Freqs

Frequency (MHz)	MaxPeak (dBµV/m)	Limit (dBµV/m)	Margin (dB)	Height (cm)	Pol	Azimuth (deg)	Corr. (dB/m)
0.019172	51.85	121.94	70.08	100.0	X	0.0	20.1
0.127037	73.99	105.52	31.53	100.0	X	262.0	20.1
0.363214	45.40	96.40	51.00	100.0	X	25.0	20.1
0.619072	35.61	71.78	36.17	100.0	X	50.0	20.1

EUT Information

EUT Name:	ZENS Fast Dual Wireless Charger
Model:	ZENDC05B/00
Test Mode:	Charging
Test Voltage::	120V/60Hz
Remark:	Temp 23 Humi:51%
Test Standard:	FCC Part 15C
Tested By:	Kei Zhang
Reviewed By:	Terry Yin

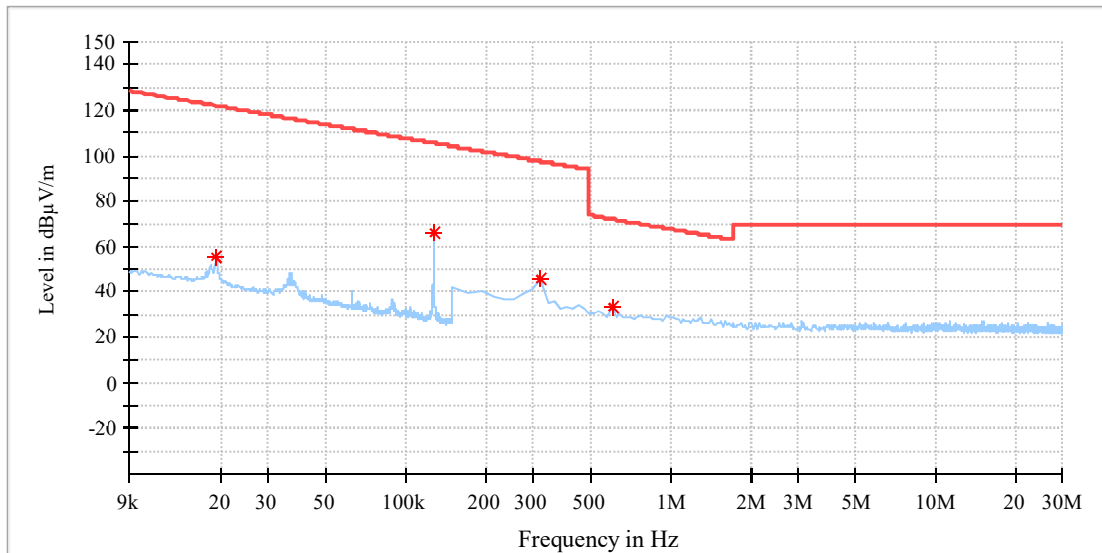

Critical_Freqs

Frequency (MHz)	MaxPeak (dBµV/m)	Limit (dBµV/m)	Margin (dB)	Height (cm)	Pol	Azimuth (deg)	Corr. (dB/m)
0.019172	55.36	121.94	66.57	100.0	Y	283.0	20.1
0.127037	66.15	105.52	39.37	100.0	Y	158.0	20.1
0.320572	45.34	97.48	52.14	100.0	Y	280.0	20.1
0.597750	33.54	72.08	38.54	100.0	Y	331.0	20.1

EUT Information

EUT Name:	ZENS Fast Dual Wireless Charger
Model:	ZENDC05B/00
Test Mode:	Charging
Test Voltage::	120V/60Hz
Remark:	Temp 23 Humi:51%
Test Standard:	FCC Part 15C
Tested By:	Kei Zhang
Reviewed By:	Terry Yin

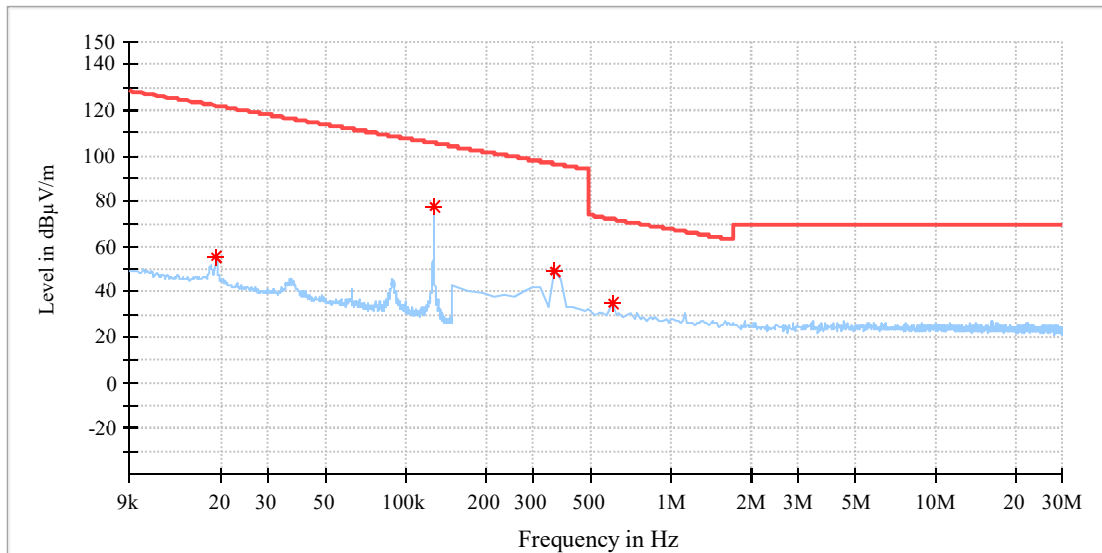

Critical_Freqs

Frequency (MHz)	MaxPeak (dBµV/m)	Limit (dBµV/m)	Margin (dB)	Height (cm)	Pol	Azimuth (deg)	Corr. (dB/m)
0.019172	55.45	121.94	66.48	100.0	Z	98.0	20.1
0.127037	77.16	105.52	28.36	100.0	Z	263.0	20.1
0.363214	49.03	96.40	47.37	100.0	Z	57.0	20.1
0.597750	34.78	72.08	37.30	100.0	Z	151.0	20.1

EUT Information

EUT Name:	ZENS Fast Dual Wireless Charger
Model:	ZENDC05B/00
Test Mode:	Charging
Test Voltage::	120V/60Hz
Remark:	Temp 23 Humi:51%
Test Standard:	FCC Part 15C
Tested By:	Kei Zhang
Reviewed By:	Terry Yin

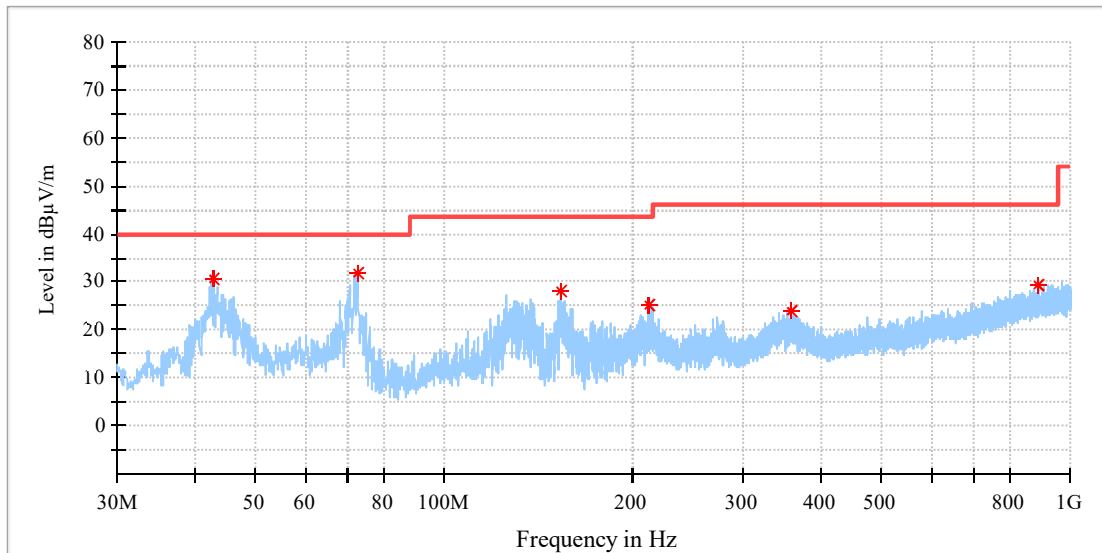

Critical_Freqs

Frequency (MHz)	MaxPeak (dBµV/m)	Limit (dBµV/m)	Margin (dB)	Height (cm)	Pol	Azimuth (deg)	Corr. (dB/m)
42.755500	30.58	40.00	9.42	100.0	H	239.0	-19.4
72.680000	31.73	40.00	8.27	100.0	H	239.0	-22.7
152.996000	27.98	43.50	15.52	100.0	H	101.0	-22.0
211.681000	25.08	43.50	18.42	100.0	H	303.0	-18.9
357.520500	23.89	46.00	22.11	100.0	H	199.0	-14.7
890.923500	29.19	46.00	16.81	100.0	H	22.0	-5.1

EUT Information

EUT Name: ZENS Fast Dual Wireless Charger
 Model: ZENDC05B/00
 Test Mode: Charging
 Test Voltage: 120V/60Hz
 Remark: Temp 23 Humi:51%
 Test Standard: FCC Part 15C
 Tested By: Kei Zhang
 Reviewed By: Terry Yin

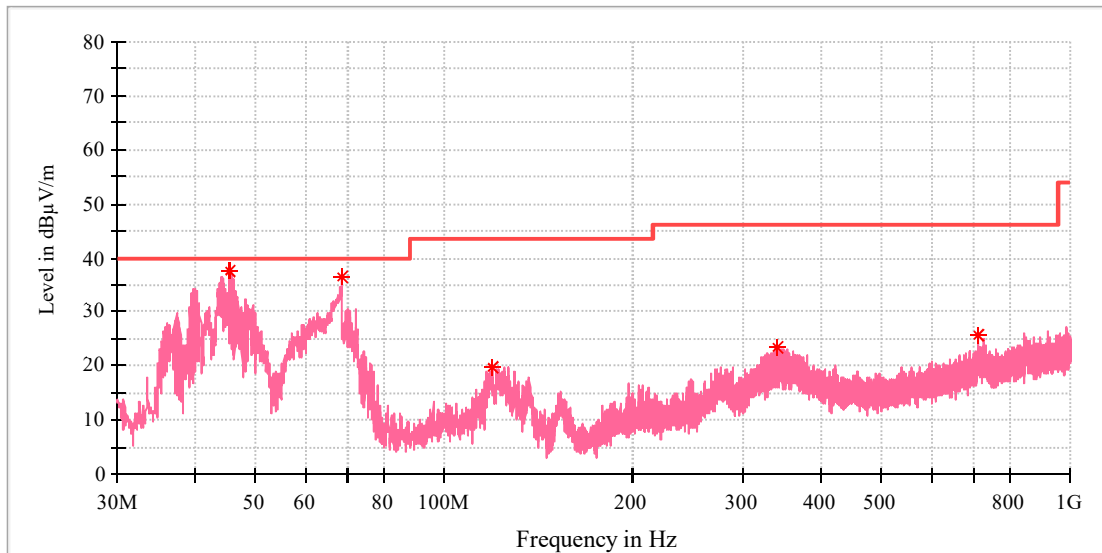

Critical_Freqs

Frequency (MHz)	MaxPeak (dBµV/m)	Limit (dBµV/m)	Margin (dB)	Height (cm)	Pol	Azimuth (deg)	Corr. (dB/m)
45.333462	37.50	40.00	2.50	100.0	V	64.0	-19.1
68.576154	36.54	40.00	3.46	100.0	V	0.0	-21.6
119.426539	19.74	43.50	23.76	100.0	V	6.0	-21.0
339.541923	23.51	46.00	22.49	100.0	V	130.0	-15.4
713.551539	25.55	46.00	20.45	100.0	V	277.0	-8.2

5.1.4 Conducted emissions

RESULT:**Pass****Test Specification**

Test standard	:	FCC Part 15.207
Basic standard	:	ANSI C63.10: 2013
Frequency range	:	150KHz - 30MHz
Classification	:	Class B
Limit	:	FCC Part 15.207 (a)
Kind of test site	:	Shielded Room

Test Setup

Date of testing	:	2021-07-20
Input voltage	:	120Vac, 60Hz
Operation mode	:	B
Ambient temperature	:	22 °C
Relative humidity	:	55 %
Atmospheric pressure	:	101 kPa

Refer to following test plots for details of test result.

EUT Information

EUT Name: ZENS Fast Dual Wireless Charger
 Order No: 168326740 40
 Model: ZENDC05B/00
 Test mode: ON (10W * 2 + Apple watch)
 Test Voltage: AC 120V/60Hz
 Test By: Mac Xie
 Review By: Gary Chen
 Remark: SR2

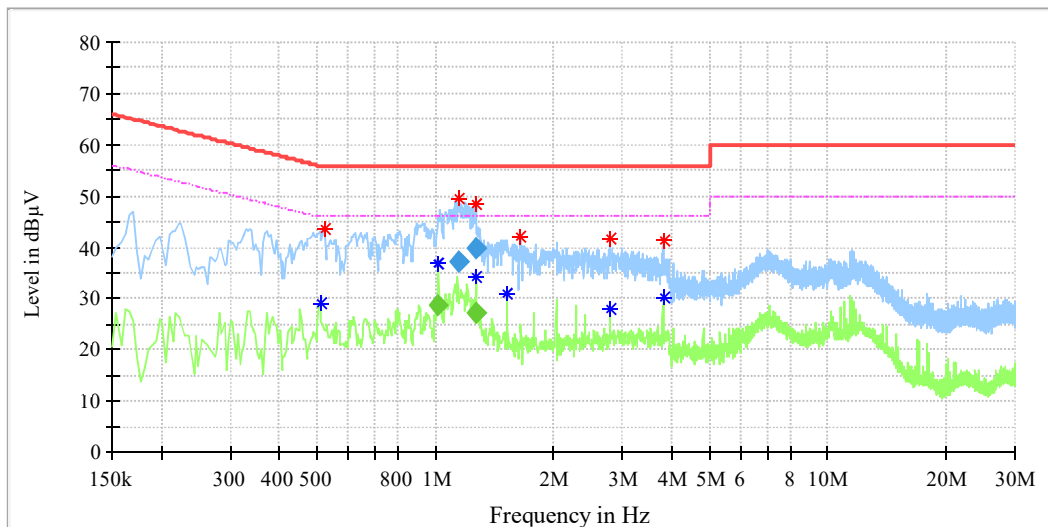

Critical Freqs

Frequency (MHz)	MaxPeak (dBµV)	Average (dBµV)	Limit (dBµV)	Margin (dB)	Line	Corr. (dB)
0.510000	---	29.12	46.00	16.88	L1	10.0
0.522000	43.44	---	56.00	12.56	L1	10.0
1.013500	---	36.84	46.00	9.16	L1	10.0
1.149500	49.51	---	56.00	6.49	L1	10.1
1.269500	48.39	---	56.00	7.61	L1	10.1
1.269500	---	34.21	46.00	11.79	L1	10.1
1.522000	---	30.84	46.00	15.16	L1	10.1
1.650000	41.98	---	56.00	14.02	L1	10.1
2.794000	41.72	---	56.00	14.28	L1	10.2
2.794000	---	28.07	46.00	17.93	L1	10.2
3.810000	41.19	---	56.00	14.81	L1	10.2
3.810000	---	30.10	46.00	15.90	L1	10.2

Final Result

Frequency (MHz)	QuasiPeak (dBµV)	Average (dBµV)	Limit (dBµV)	Margin (dB)	Meas. Time (ms)	Bandwidth (kHz)	Line	Corr. (dB)
1.013500	---	28.51	46.00	17.49	200.0	9.000	L1	10.0
1.149500	37.37	---	56.00	18.63	200.0	9.000	L1	10.1
1.269500	39.96	---	56.00	16.04	200.0	9.000	L1	10.1
1.269500	---	27.13	46.00	18.87	200.0	9.000	L1	10.1

EUT Information

EUT Name:	ZENS Fast Dual Wireless Charger
Order No:	168326740 40
Model:	ZENDC05B/00
Test mode:	ON (10W * 2 + Apple watch)
Test Voltage:	AC 120V/60Hz
Test By:	Mac Xie
Review By:	Gary Chen
Remark:	SR2

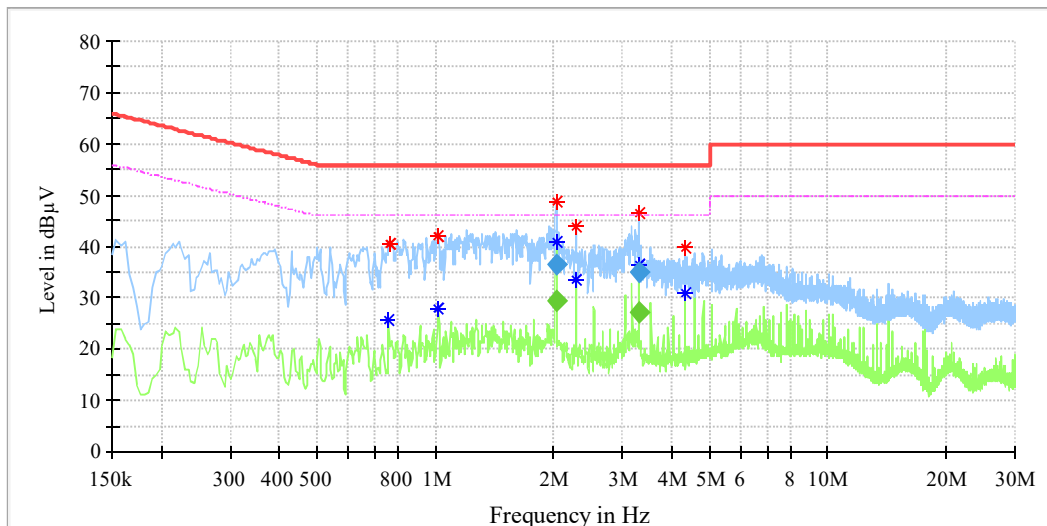

Critical_Freqs

Frequency (MHz)	MaxPeak (dBµV)	Average (dBµV)	Limit (dBµV)	Margin (dB)	Line	Corr. (dB)
0.762000	---	25.74	46.00	20.26	N	9.8
0.766000	40.55	---	56.00	15.45	N	9.8
1.018000	42.12	---	56.00	13.88	N	9.8
1.018000	---	27.80	46.00	18.20	N	9.8
2.033500	48.77	---	56.00	7.23	N	9.9
2.033500	---	40.76	46.00	5.24	N	9.9
2.286000	43.87	---	56.00	12.13	N	9.9
2.286000	---	33.61	46.00	12.39	N	9.9
3.301500	46.61	---	56.00	9.39	N	9.9
3.301500	---	36.49	46.00	9.51	N	9.9
4.314000	39.90	---	56.00	16.10	N	9.9
4.318000	---	31.06	46.00	14.94	N	9.9

Final_Result

Frequency (MHz)	QuasiPeak (dBµV)	Average (dBµV)	Limit (dBµV)	Margin (dB)	Meas. Time (ms)	Bandwidth (kHz)	Line	Corr. (dB)
2.033500	---	29.46	46.00	16.54	200.0	9.000	N	9.9
2.033500	36.65	---	56.00	19.35	200.0	9.000	N	9.9
3.301500	---	27.20	46.00	18.80	200.0	9.000	N	9.9
3.301500	34.92	---	56.00	21.08	200.0	9.000	N	9.9

6 Photographs of the Test Set-Up

For photographs of the test set-up, refer to the appendix A.

7 List of Tables

Table 1: List of Test and Measurement Equipment.....	5
Table 2: Technical Specification of EUT	8
Table 3: List of Accessories and Auxiliary Equipment.....	10