TEST REPORT

Report No.: SRTC2021-9003(F)-0060
Product Name: Smart Phone
Model Name: F-52B
Applicant: FCNT LIMITED
Manufacturer: FCNT LIMITED
Specification: FCC Part15B (Certification)
(2021 edition)
ANSI C63.4-2014
FCC ID: 2AYY9FMP188

The State Radio_monitoring_center Testing Center (SRTC)
15th Building, No.30 Shixing Street, Shijingshan District,
Beijing, China

Tel: 86-10-57996183 Fax: 86-10-57996388

CONTENTS

1. General information	3
1.1 Notes of the test report	3
1.2 Information about the testing laboratory.....	3
1.3 Applicant's details	3
1.4 Manufacturer's details.....	3
1.5 Application details	4
1.6 Reference specification.....	4
1.7 Information of EUT.....	4
1.7.1 General information.....	4
1.7.2EUT details	5
1.7.3 Auxiliary equipment details.....	5
2. Test information	6
2.1 Summary of the test results	6
2.2 Test result.....	7
2.2.1Conducted Emissions-FCC Part15.107	7
2.2.2RadiatedEmissions-FCC Part15.109.....	13
2.3. List of test equipments	22

1. General information

1.1 Notes of the test report

The test report may only be reproduced or published in full. Reproduction or publication of extracts from the report requires the prior written permission of The State Radio_monitoring_center Testing Center (SRTC).

The test results relate only to individual items of the samples which have been tested.

1.2 Information about the testing laboratory

Company: The State Radio_monitoring_center Testing Center (SRTC)
Address: 15th Building, No.30 Shixing Street, Shijingshan District
Testing location: No.80, Zhaojiachang, BeizangCun, Daxing District, Beijing, China.
City: Beijing
Country or Region: China
Contacted person: Liu Jia
Tel: +86 10 57996183
Fax: +86 10 57996388
Email: liujiaf@srtc.org.cn

1.3 Applicant's details

Company: FCNT LIMITED
Address: Chuorinkan 7-10-1 Yamato, Kanagawa 2420007, Japan
City: Yamato
Country or Region: Japan
Contacted person: Masahiro Kurosawa
Tel: +81-50-3358-3533
Email: kurosawa_masa@fcnt.com

1.4 Manufacturer's details

Company: FCNT LIMITED
Address: Chuorinkan 7-10-1 Yamato, Kanagawa 2420007, Japan
City: Yamato
Country or Region: Japan
Contacted person: Masahiro Kurosawa
Tel: +81-50-3358-3533
Email: kurosawa_masa@fcnt.com

1.5 Application details

Date of reception of test sample: 21th Oct. 2021

Date of test: 21th Oct. 2021 to 5th Nov. 2021

1.6 Reference specification

FCC Part 15B, 2021 (Certification)

1.7 Information of EUT

1.7.1 General information

Name of EUT	Smart Phone
Model Name	F-52B
FCC ID	2AYY9FMP188
Frequency Range	GSM: GSM850/PCS1900 WCDMA: FDD V LTE:FDD 5/ FDD 12 Bluetooth: 2.4~2.4835GHz WiFi: 2.4~2.4835GHz/ 5.15-5.25GHz/5.25-5.35GHz 5.475-5.725GHz/5.725-5.85GHz NFC: 13.56MHz
Equipment Class	Class B
Power Supply	Battery or Charger
Rated Power Supply Voltage	3.9V
Extreme Temperature	Lowest: -10°C Highest: +55°C
Extreme Voltage	Minimum: 3.51V Maximum: 4.29V
HW Version	V1.3.0
SW Version	V02R037A

1.7.2 EUT details

	Product Name	Model Name	IMEI
EUT	Smart Phone	F-52B	EUT: 354863300009043

1.7.3 Auxiliary equipment details

AE (Auxiliary Equipment) 1#: Laptop

Manufacturer	Lenovo
Model Number	E40-70
S/N	MP06WE9U
Input Voltage	100V-240V AC

AE (Auxiliary Equipment) 2#: USB Cable

Manufacturer	SONY
Model Number	AI-0162

AE (Auxiliary Equipment) 3#: Battery

Type	Li-Lon
Manufacturer	FCNT LIMITED
Model Number	RA54310-0101

AE (Auxiliary Equipment) 4#: Charger

Manufacturer	SONY
Model Number	AC-0060-TW
Input Voltage	100V-240V AC
Output Voltage	5V DC

AE (Auxiliary Equipment) 5#: Headset

Manufacturer	SONY
Model Number	MH750

Note2: As the information described in these above tables, the relevant tests have been performed in order to verify in which supply would have the worst features. When the EUT exercised with 2# USB Cable, 3# Battery, 4# Charger, 5# Headset is the worst feature, and record the results in the test report.

Note3: AE1# Laptop, 2# USB Cable, 4# Charger, 5# Headset were only cooperated with this test, not for sale.

2. Test information

2.1 Summary of the test results

No.	Test case	FCC reference	Verdict
1	Conducted emissions	15.107	Pass
2	Radiated emissions	15.109	Pass

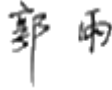
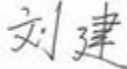
Approved By: Mr. Liu Wei Director of the test department 	Checked By: Mr. Guo Yu Vice director of the test department 
Tested by: Mr. Liu Jian Test engineer 	Issued date: 2021.11.5

2.2 Test result

2.2.1 Conducted Emissions-FCC Part15.107

Ambient condition:

Temperature	Relative humidity	Pressure
24.2°C	43.1%	101.0kPa

Test Setup with laptop:

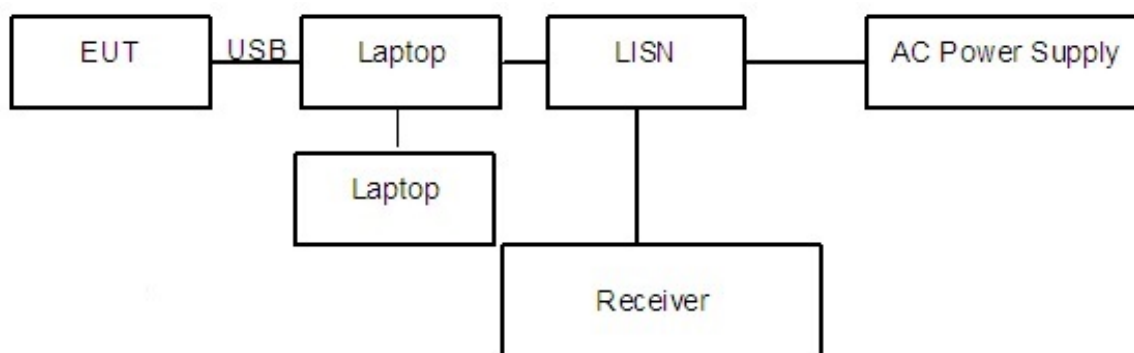

Figure 1

Test Procedure:

The EUT is placed on a non-metallic table 0.8m above the horizontal metal reference ground plane. The EUT was connected with a laptop via the USB cable and transferred the data by copying large files from laptop to the EUT. The laptop's LAN port is connected with another laptop via cable. And the data transferring between two laptops is maintained.

The AC main power supply of the laptop is connected to LISN and LISN is connected to the reference ground. The test set-up and the test methods are performed according to ANSI C63.4:2014.

Then start the test software EMC32. Sweep the whole frequency band through the range from 150 KHz to 30 MHz with RBW 9kHz, VBW 30kHz. The measurement should be done for both L line and N line. During pre-test, the receiver uses both peak detector and average detector. And the final test, the receiver uses both average detector and Quasi-peak detector.

The data of cable loss has been calibrated in full testing frequency range before the testing.

Test Setup with charger:

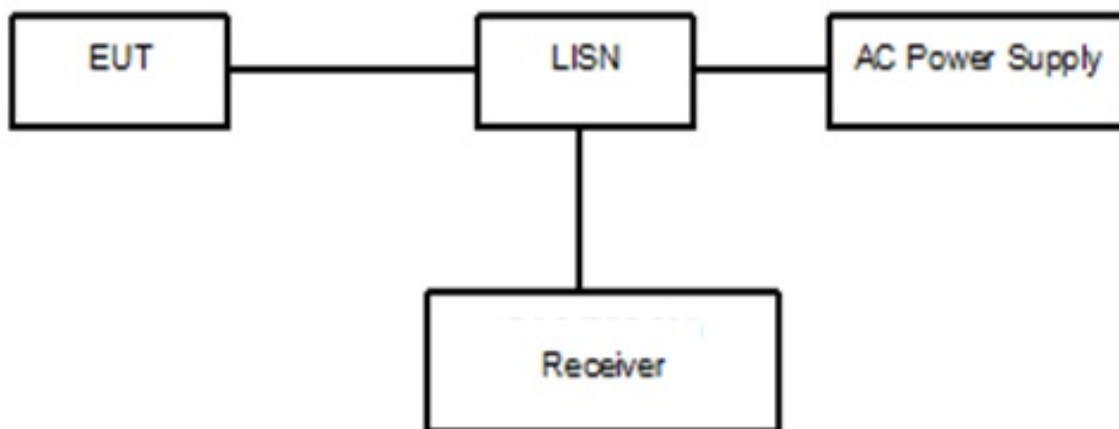

Figure 2

Test Procedure:

The EUT is placed on a non-metallic table 0.8m above the horizontal metal reference ground plane. The EUT is connected with LISN via the charger. The LISN is connected to the reference ground.

The test set-up and the test methods are performed according to ANSI C63.4:2014. Then start the test software EMC32. Sweep the whole frequency band through the range from 150 KHz to 30 MHz with RBW 9kHz, VBW 30kHz. The measurement should be done for both L line and N line. During pre-test, the receiver uses both peak detector and average detector. And the final test, the receiver uses both average detector and Quasi-peak detector.

The data of cable loss has been calibrated in full testing frequency range before the testing.

A "reference path loss" Corr.(dB) is established and the $L_{cable} + ATT + VDF$ is the attenuation of "reference path loss", and including the cable loss, the attenuation of the attenuator, the voltage division factor of AMN.

The measurement results are obtained as described below:

$$P_{result} = P_{mea} + Corr.(dB)$$

Sample calculation: $(39.43dB\mu V) = (9.73dB\mu V) + (29.7dB)$, the corresponding frequency is 0.162793MHz.

Frequency (MHz)	QuasiPeak (dB μ V)	Average (dB μ V)	Limit (dB μ V)	Margin (dB)	Line	Corr. (dB)	Pmea QuasiPeak (dB μ V)	Pmea Average (dB μ V)
0.162793	39.43	---	65.32	25.89	L1	29.7	9.73	---

Limit:

Frequency of Emission(MHz)	Limits(dB μ V)	
	Quasi-peak	Average
0.15~0.5	66 to 56*	56 to 46*
0.5~5	56	46
5~30	60	50

Note: * Decreases with the logarithm of the frequency

Test result:

Noise Level of the Measuring Instrument

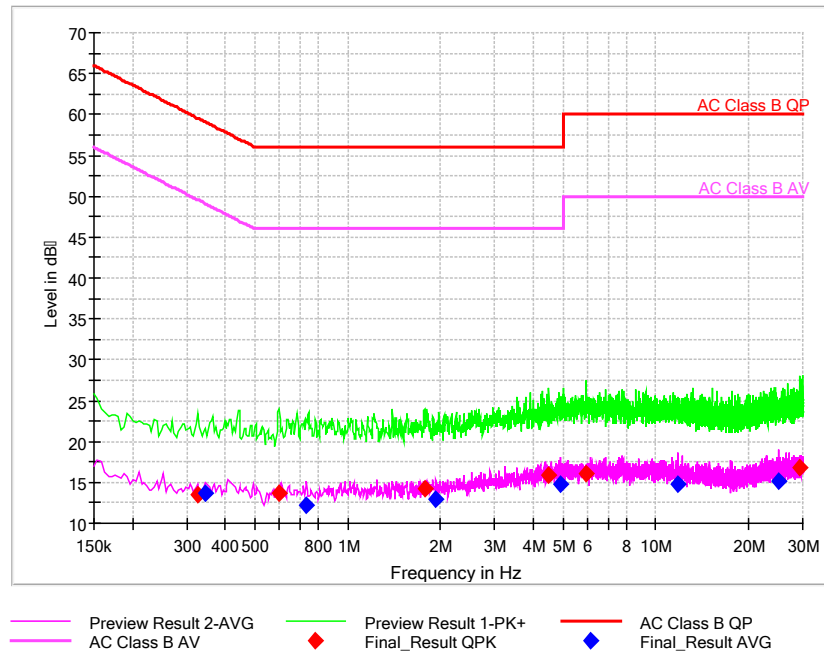

Pic1. Conducted emission L and N Line

EUT + Charger: AC240V

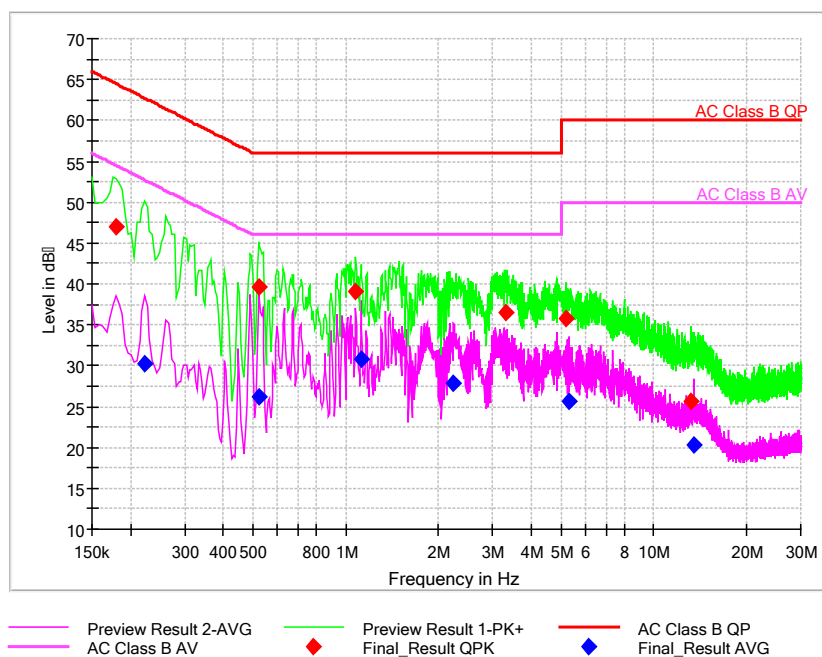

Pic2. Conducted emission L&N Line

Frequency (MHz)	QuasiPeak (dB μ V)	Average (dB μ V)	Limit (dB μ V)	Margin (dB)	Line	Corr. (dB)	Pmea QuasiPeak (dB μ V)	Pmea Average (dB μ V)
0.17985	47.03	---	64.49	17.47	L1	29.7	17.33	---
0.222493	---	30.17	52.73	22.56	L1	29.7	---	0.47
0.520993	39.59	---	56	16.41	N	29.8	9.79	---
0.520993	---	26.11	46	19.89	N	29.8	---	-3.69
1.07535	39	---	56	17	N	29.8	9.2	---
1.122257	---	30.72	46	15.28	N	29.8	---	0.92
2.243764	---	27.79	46	18.21	N	29.8	---	-2.01
3.292779	36.45	---	56	19.55	L1	29.8	6.65	---
5.186121	35.83	---	60	24.17	N	29.9	5.93	---
5.322579	---	25.6	50	24.4	N	29.9	---	-4.3
13.17313	25.6	---	60	34.4	N	30.1	-4.5	---
13.56118	---	20.38	50	29.62	N	30.1	---	-9.72

EUT + Charger: AC120V

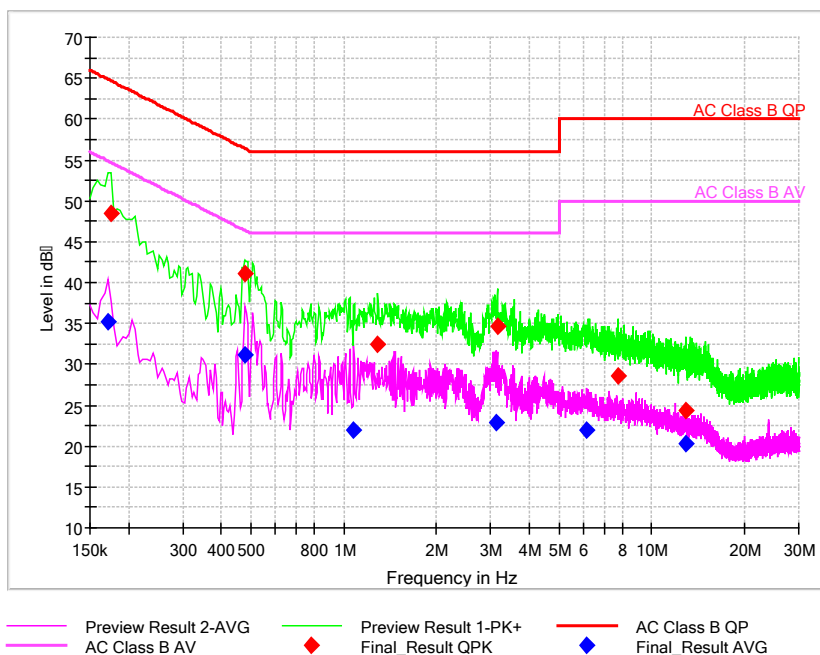

Pic3. Conducted emission L&N Line

Frequency (MHz)	QuasiPeak (dBμV)	Average (dBμV)	Limit (dBμV)	Margin (dB)	Line	Corr. (dB)	Pmea QuasiPeak (dBμV)	Pmea Average (dBμV)
0.171321	---	35.29	54.9	19.61	L1	29.7	---	5.59
0.175586	48.4	---	64.69	16.29	L1	29.7	18.7	---
0.47835	---	31.15	46.37	15.21	L1	29.7	---	1.45
0.47835	41.06	---	56.37	15.31	L1	29.7	11.36	---
1.079614	---	22.03	46	23.97	L1	29.8	---	-7.77
1.292829	32.52	---	56	23.48	L1	29.8	2.72	---
3.117943	---	22.85	46	23.15	L1	29.8	---	-6.95
3.147793	34.63	---	56	21.37	L1	29.8	4.83	---
6.158379	---	22.01	50	27.99	L1	29.8	---	-7.79
7.744693	28.58	---	60	31.42	L1	29.9	-1.32	---
12.83625	24.4	---	60	35.6	N	30	-5.6	---
12.89595	---	20.38	50	29.62	N	30	---	-9.62

EUT + Laptop:

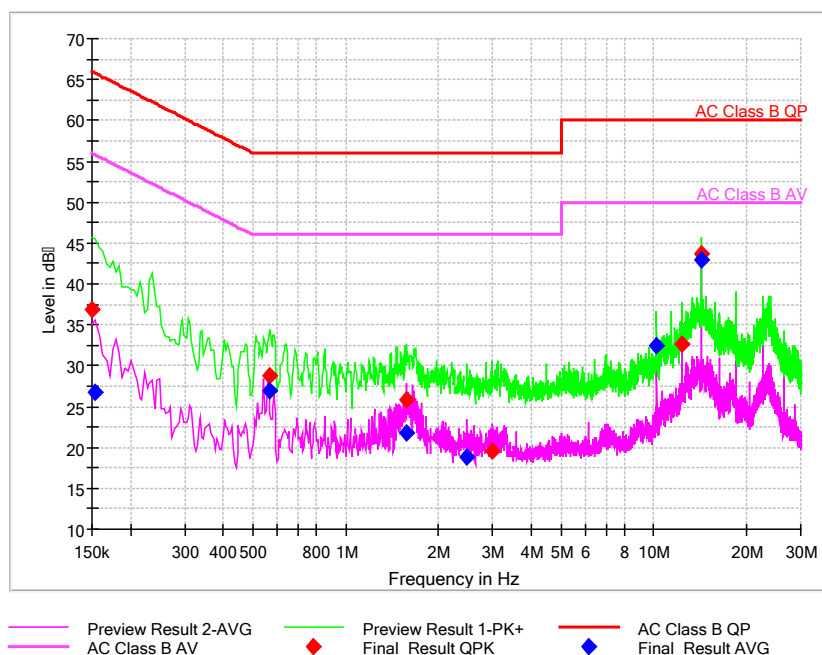

Pic4. Conducted emission L&N Line

Frequency (MHz)	QuasiPeak (dB μ V)	Average (dB μ V)	Limit (dB μ V)	Margin (dB)	Line	Corr. (dB)	Pmea QuasiPeak (dB μ V)	Pmea Average (dB μ V)
0.15	36.93	---	66	29.07	L1	29.7	7.23	---
0.154264	---	26.81	55.77	28.96	N	29.8	---	-2.99
0.563636	---	26.96	46	19.04	N	29.8	---	-2.84
0.5679	28.8	---	56	27.21	N	29.8	-1	---
1.574271	---	21.81	46	24.19	N	29.8	---	-7.99
1.574271	25.82	---	56	30.18	N	29.8	-3.98	---
2.4783	---	18.81	46	27.19	N	29.8	---	-10.99
2.994279	19.6	---	56	36.4	N	29.9	-10.3	---
10.2393	---	32.49	50	17.51	L1	29.9	---	2.59
12.29042	32.67	---	60	27.33	N	30	2.67	---
14.33728	---	42.97	50	7.03	N	30.1	---	12.87
14.33728	43.63	---	60	16.37	N	30.1	13.53	---

2.2.2 Radiated Emissions-FCC Part15.109

Ambient condition:

Temperature	Relative humidity	Pressure
24.5°C	43.4%	101.0kPa

Test Setup:

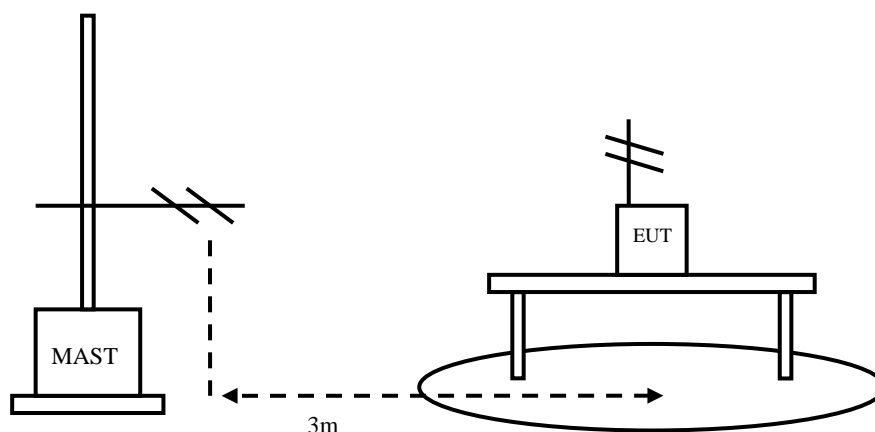

Figure 3

Test Procedure:

EUT+Laptop:

The EUT should be placed on a non-metallic table 80cm above the ground plane. The receive antennas shall be moved from 1 to 4 meters. The distance between EUT and receive antenna should be 3 meters.

The EUT was connected with a laptop via the USB cable and transferred the data between the laptop and the EUT. The test set-up and the test methods are performed according to ANSI C63.4:2014

Then start the test software EMC32. Sweep the whole frequency band through the range from 30MHz to 1GHz, using receive log period antenna VULB 9163.

During the test, the height of receive antenna shall be moved from 1 to 4 meters, and the antenna shall be performed under horizontal and vertical polarization. The turn table shall be rotated from 0 to 360 degrees for detecting the maximum of radiated spurious signal level. The measurements shall be repeated with orthogonal polarization of the test antenna. The EUT is laid in two modes as follow:
1. put the EUT in horizontal direction; 2. put the EUT in vertical direction.

The data of cable loss and antenna factor have been calibrated in full testing

frequency range before the testing.

EUT + Charger:

The EUT should be placed on a non-metallic table 80cm above the ground plane. The receive antennas shall be moved from 1 to 4 meters. The distance between EUT and receive antenna should be 3 meters.

The EUT should work in idle mode. The test set-up and the test methods are performed according to ANSI C63.4:2014.

Then start the test software EMC32. Sweep the whole frequency band through the range from 30MHz to 1GHz, using receive log period antenna VULB 9163.

During the test, the height of receive antenna shall be moved from 1 to 4 meters, and the antenna shall be performed under horizontal and vertical polarization. The turn table shall be rotated from 0 to 360 degrees for detecting the maximum of radiated spurious signal level. The measurements shall be repeated with orthogonal polarization of the test antenna. The EUT is laid in two modes as follow:
 1. put the EUT in horizontal direction; 2. put the EUT in vertical direction.

The data of cable loss and antenna factor have been calibrated in full testing frequency range before the testing. All test results are performed with max hold at the horizontal and vertical polarity.

RBW=120kHz, VBW=300kHz, when the test frequency: 30MHz<f<1GHz

RBW=1MHz, VBW=3MHz, when the test frequency: f>1GHz

A “reference path loss” is established and the A_{Rpl} is the attenuation of “reference path loss”, and including the gain of receive antenna, the gain of the preamplifier, the cable loss.

The measurement results are obtained as described below:

$$\text{Result} = P_{\text{mea}} + A_{Rpl}$$

Limit:

Frequency of Emission(MHz)	Limits	
	Detector	Unit (dB μ V/m)
30~88	Quasi-peak	40
88~216	Quasi-peak	43.5
216~960	Quasi-peak	46
960~1000	Quasi-peak	54
1000~5th harmonic of the highest frequency or 40GHz, whichever is lower	Average	54
	Peak	74

Test result:

Sample calculation: $(24.61\text{dB}\mu\text{V}/\text{m}) = (36.61\text{dB}\mu\text{V}) + (-12\text{dB}/\text{m})$, the corresponding frequency is 30 MHz.

Frequency(MHz)	Result(dB μ V/m)	Limit (dB μ V/m)	ARpl (dB/m)	Pmea (dB μ V)	Polarity
30	24.61	40.00	-12	36.61	V

EUT + Laptop:

Frequency(MHz)	Result(dB μ V/m)	Limit (dB μ V/m)	ARpl (dB/m)	Pmea (dB μ V)	Polarity
61.1855	20.01	40.00	-19.2	39.21	V
83.932	18.17	40.00	-23.2	41.37	V
268.426	23.12	46.00	-16.7	39.82	V
319.4965	24.18	46.00	-15.4	39.58	V
491.72	17.19	46.00	-11	28.19	V
932.003	19.62	46.00	-2.9	22.52	V

EUT + Charger:

Frequency(MHz)	Result(dB μ V/m)	Limit (dB μ V/m)	ARpl (dB/m)	Pmea (dB μ V)	Polarity
40.0395	16.43	40.00	-18.5	34.93	V
48.3815	20.2	40.00	-17.6	37.8	V
57.645	15.94	40.00	-18.5	34.44	V
80.343	17.29	40.00	-24.4	41.69	V
96.833	20.41	43.50	-19.8	40.21	V
613.1155	13.53	46.00	-8	21.53	V

EUT + Laptop: refer to Pic5, Pic6, Pic7, Pic8, Pic9

Full Spectrum

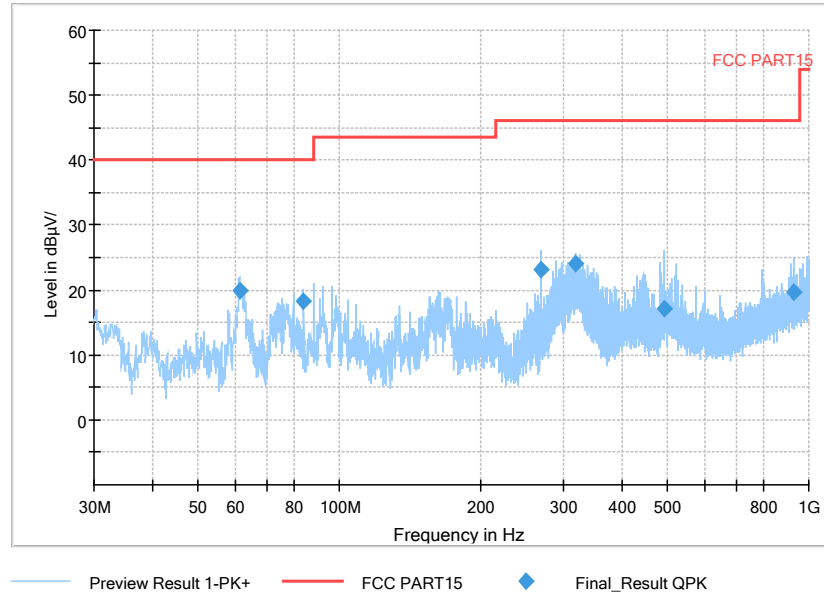

Pic5. Radiated emission(30MHz – 1GHz)

Note: The test data in the graph includes two polarizations: horizontal and vertical

Full Spectrum

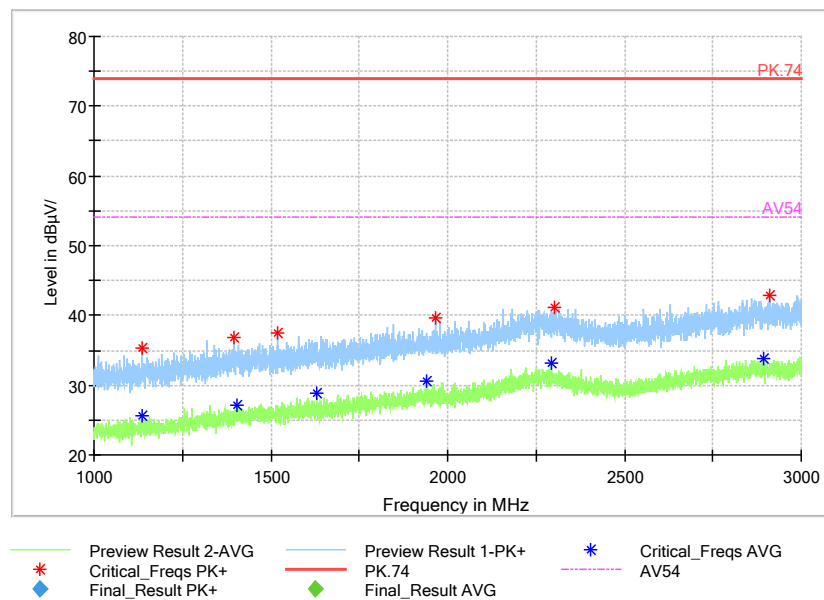

Pic6. Radiated emission (1GHz –3GHz)

Note: The test data in the graph includes two polarizations: horizontal and vertical.

Full Spectrum

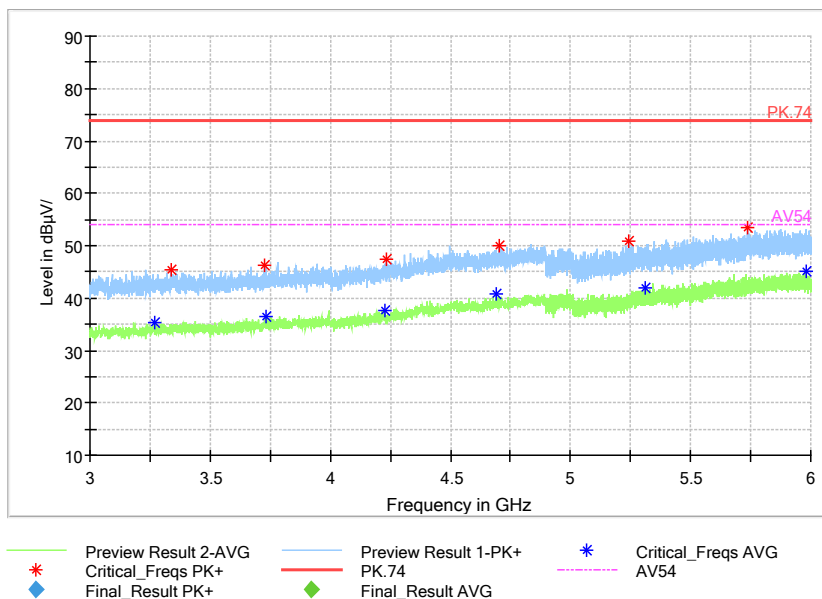

Pic7. Radiated emission (3GHz –6GHz)

Note: The test data in the graph includes two polarizations: horizontal and vertical.

Full Spectrum

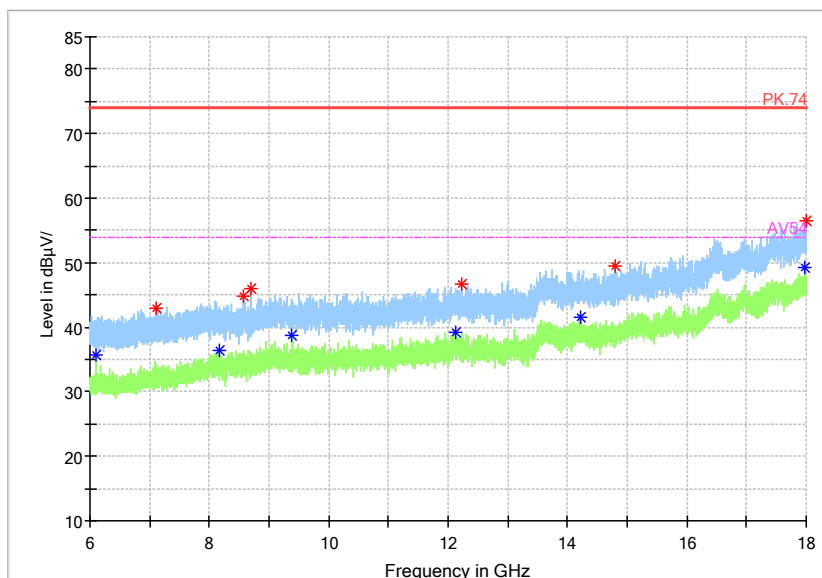

Pic8. Radiated emission (6GHz –18GHz)

Note: The test data in the graph includes two polarizations: horizontal and vertical.

Full Spectrum

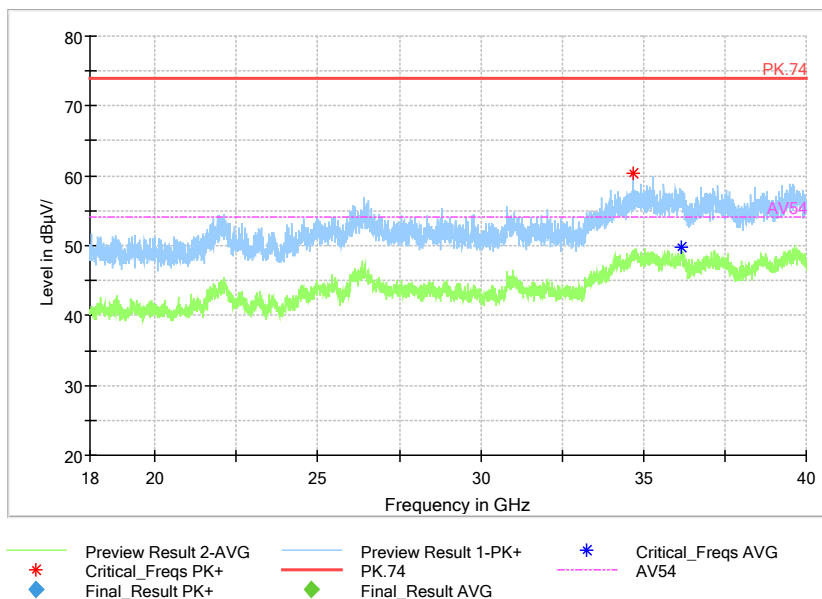

Pic9. Radiated emission (18GHz – 40GHz)

Note: The test data in the graph includes two polarizations: horizontal and vertical.

EUT + Charger: refer to Pic10, Pic11, Pic12, Pic13, Pic14

Full Spectrum

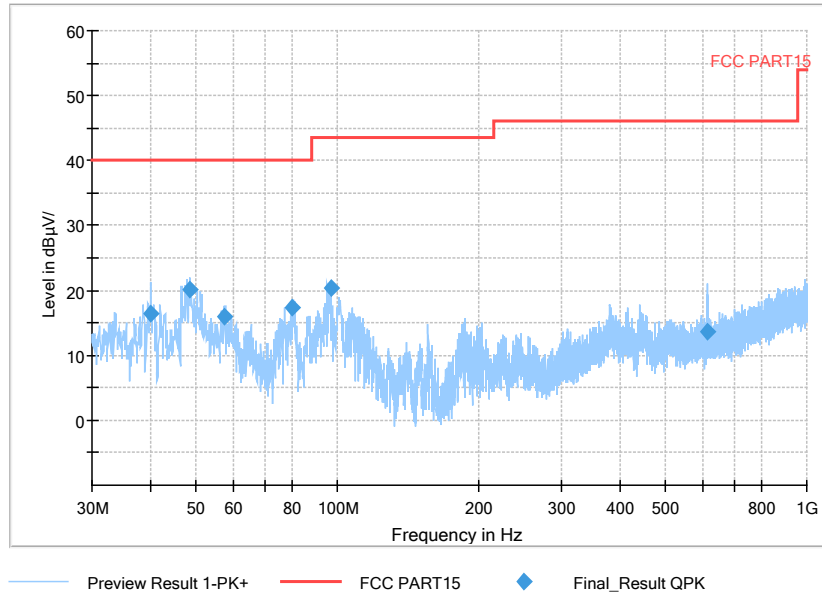

Pic10. Radiated emission(30MHz – 1GHz)

Note: The test data in the graph includes two polarizations: horizontal and vertical

Full Spectrum

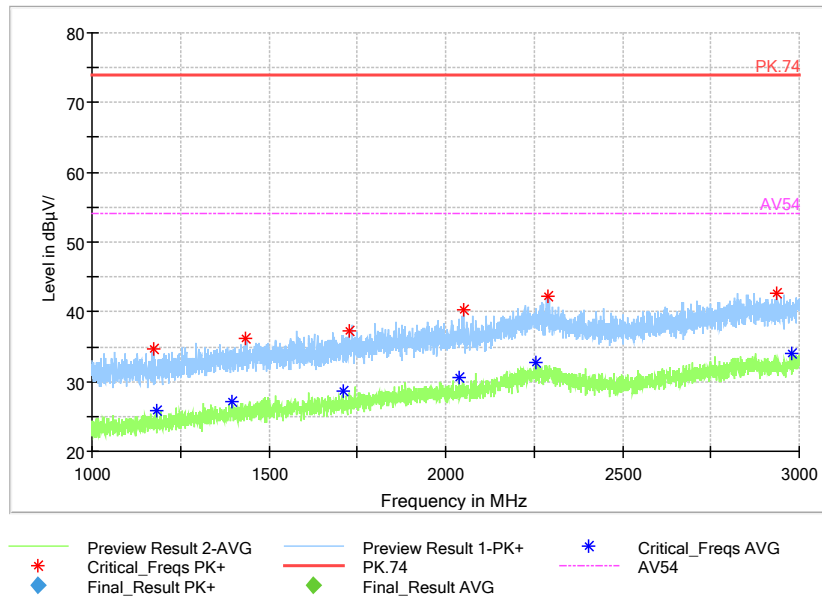

Pic11. Radiated emission (1GHz –3GHz)

Note: The test data in the graph includes two polarizations: horizontal and vertical.

Full Spectrum

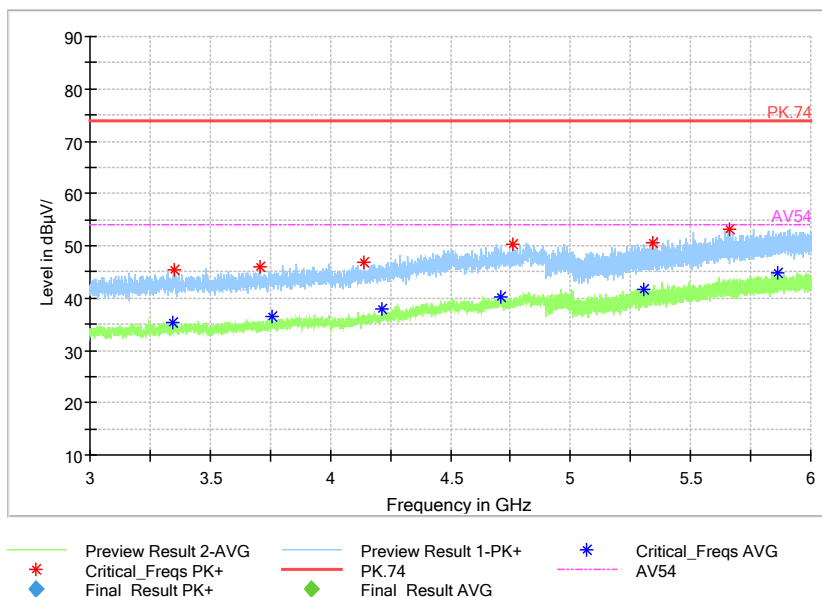

Pic12. Radiated emission (3GHz –6GHz)

Note: The test data in the graph includes two polarizations: horizontal and vertical.

Full Spectrum

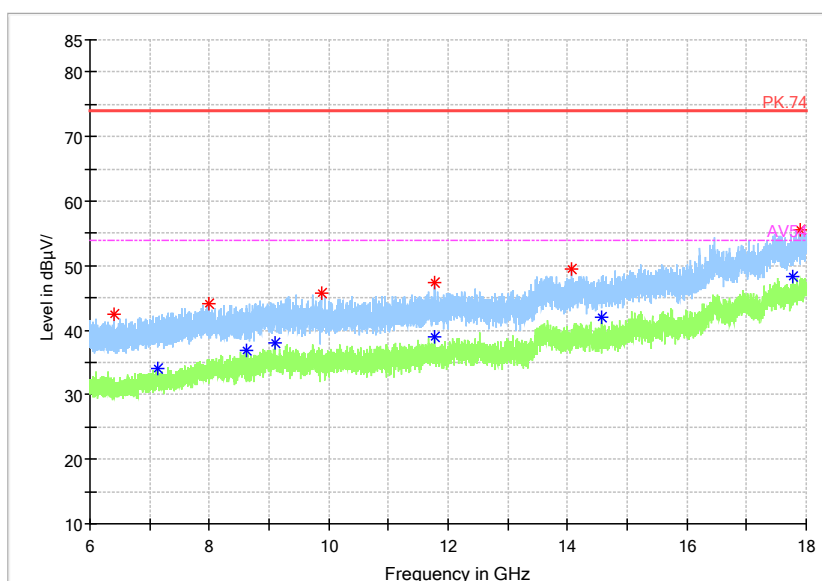

Pic13. Radiated emission (6GHz –18GHz)

Note: The test data in the graph includes two polarizations: horizontal and vertical.

Full Spectrum

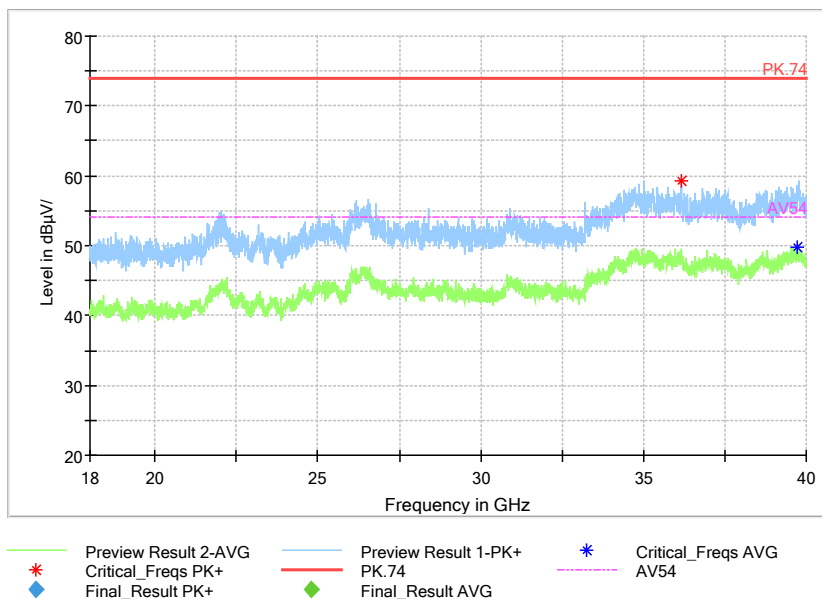

Pic14. Radiated emission (18GHz – 40GHz)

Note: The test data in the graph includes two polarizations: horizontal and vertical.

2.3. List of test equipments

No.	Name/Model	Manufacturer	S/N	Calibration Due Date	Calibration Date
1	23.18m×16.88m×9.60mS emi-AnechoicChamber	FRANKONIA	-----	5th Sep. 2023	6th Sep. 2018
2	ESW EMI test receiver	R&S	101574	20th June 2022	20th June 2021
3	ESR3 EMI test receiver	R&S	102361	11th Apr. 2022	11th Apr. 2021
4	9.080m×5.255m×3.525m Shielding room	FRANKONIA	-----	5th Sep. 2023	6th Sep. 2020
5	VULB 9163 Ultra log test antenna	schwarzbeck	867	28th May 2023	28th May 2021
6	HF 907 Double-Ridged Waveguide Horn Antenna	R&S	100512	13th Apr. 2023	13th Apr. 2021
7	SAS-574 Horn Antenna	schwarzbeck	535	21th Apr. 2023	21th Apr. 2021
8	ENV216 AMN	R&S	101881	20th June 2022	20th June 2021
9	EMC32EMI test software	R&S	-----	-----	-----