



## Linde Guardian System

## Original instructions



## Linde Material Handling – Your Partner



Selling over 125,000 forklift and warehouse trucks per year, Linde Material Handling ranks as one of the leading intralogistics manufacturers and solution providers.

And there is a reason for this success. Linde products not only win over customers with their innovative technology with a reputation for excellent performance, but in particular with reduced energy and operating costs, which are up to 40% lower than those of the competition.

The high level of manufacturing quality is also a benchmark for the quality of our advice and services. With an extensive network of distri-

bution partners, we are at our customers' disposal both around the clock and around the world.

Your local Linde dealer offers a complete service package from a single source — from expert advice to sales and servicing, and with the right financing, of course. Whether leasing, hiring or hire purchase — you maintain your flexibility. In your work and in your decisions.

KION North America  
2450 W 5th N St  
Summerville, SC 29483  
Telephone: 843-875-8000  
Website: <http://www.kion-na.com>



<b>1</b>	<b>Introduction</b>	
	Linde Guardian System.....	2
	Intended use .....	5
	Limitations for commissioning or for the permission to operate.....	6
	Symbols used.....	7
<b>2</b>	<b>Safety</b>	
	Safety information .....	10
	General safety instructions.....	12
	Service personnel.....	13
<b>3</b>	<b>Operating devices and display elements</b>	
	Overview .....	16
	Truck Unit.....	17
	Truck Unit 2.....	23
	Truck Unit Small.....	28
	Truck Unit Small 2 .....	31
	Distance Beeper.....	34
	Charging station .....	37
	Sensor Truck Unit.....	39
	Static Unit.....	40
	Zone Marker .....	43
	Programmer .....	45
<b>4</b>	<b>Operation</b>	
	Installation.....	49
	Attaching the Distance Beeper.....	49
	Installing a Static Unit.....	50
	Installing the Zone Marker .....	51
	<b>Pre-shift checks</b> .....	52
	Service plan.....	52
	Checking the charge state of the Distance Beeper .....	53
	Checking the function of the Distance Beeper .....	53
	Charging the Distance Beeper .....	54
	Checking the operational readiness of the Truck Unit.....	56



Checking the operational readiness sensors .....	57
Performing a functional test.....	58
<b>Operation.....</b>	<b>61</b>
Switching on the Truck Unit 1/2 .....	61
Switching on the Distance Beeper.....	61
Pairing the Distance Beeper.....	62
Displays during operation .....	63
<b>5 Maintenance and disposal</b>	
<b>Maintenance.....</b>	<b>71</b>
<b>Disposal.....</b>	<b>72</b>
<b>6 Technical data</b>	
<b>Truck Unit.....</b>	<b>74</b>
<b>Truck Unit 2.....</b>	<b>75</b>
<b>Distance Beeper.....</b>	<b>76</b>
<b>Sensor Truck Unit.....</b>	<b>77</b>
<b>Truck Unit Small .....</b>	<b>78</b>
<b>Truck Unit Small 2 .....</b>	<b>79</b>
<b>Static Unit.....</b>	<b>80</b>
<b>Zone Marker .....</b>	<b>81</b>
<b>Programmer .....</b>	<b>82</b>

**1**

---

# **Introduction**

## Linde Guardian System

### Linde Guardian System

The Linde Guardian System is a system for the working environment of industrial trucks. It gives signals to the driver and pedestrians in case of proximity.

#### DANGER

**It is explicitly not a safety system!**

As the Linde Guardian System does not exempt the driver and all people within the workplace from their responsibility and duty of care, drivers and all other people have to ensure that they are behaving in a safe manner in all situations.

- Always perform a functional test before starting work.

#### Functional description

The Linde Guardian System is a wireless radio-based assistance system for giving signals to people and objects in defined detection areas in industrial environments.

The system wirelessly measures the distance between the component mounted on the industrial truck, components at fixed positions in the working area and the mobile components that individuals carry on their person.

In this way, the Linde Guardian System can effectively use LED displays, sounds and vibration alarms to inform people of the presence of industrial trucks. For an early and effective signal, the Truck Unit has configurable signaling zones. The shape of the zones are designed to respect the typical movement of an industrial truck.

The size of the areas can be configured and have to be adapted to the work environment before initial commissioning.

The extended area can be configured in such a way that it covers a cone shaped area to the front and rear (1). Within this area, the direction towards people equipped with a Distance Beeper is displayed.

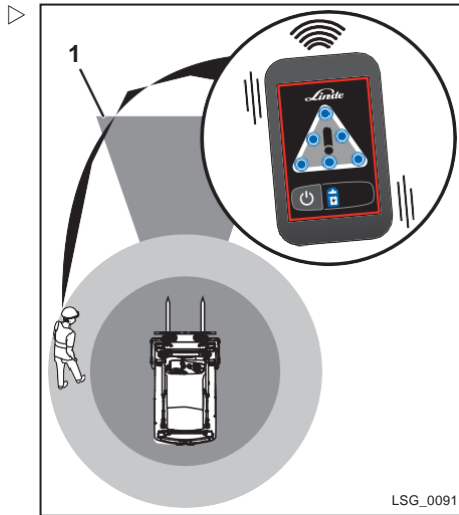

LSG\_0091



## Components

As standard, Linde Guardian System contains the following components. The description is structured in truck, fixed and mobile components:

### Truck Components

#### **TRUCK UNIT**

The Truck Unit is the display unit for the truck driver. Sensors are connected via cables to detect fixed and mobile components via local radio network.

#### **SENSORS**

Sensors that are connected to the Truck Unit. Typically, four sensors are used per truck.

#### **5<sup>th</sup> SENSOR**

Additional sensor for signaling that another industrial truck with Truck Unit is in proximity.

#### **TRUCK UNIT SMALL**

Truck Unit Small to interact with fixed components and between trucks. Detection of mobile components is not possible.

### Fixed Components

#### **STATIC UNIT**

For signals at points that are difficult to overview.

#### **ZONE MARKER**

For setting up zones in which Truck Units give optical signals and optionally can give a signal to the truck interface, so that for example the truck reduces the speed.

### Mobile Components

#### **DISTANCE BEEPER**

Gives a signal if it is inside the detection zone of Truck Units or optionally Static Units or Zone Markers.

#### **INDUCTIVE CHARGING**

Inductive charging station for the Distance Beeper.

## Linde Guardian System

### User Groups

During the installation, setup and usage different user groups are needed to ensure the correct usage of the system and the correct behavior of the people interacting with it. The following definition of the user groups will be used throughout this manual.

#### **USER**

The user of the system is either the driver of the industrial vehicle or the pedestrian wearing the signaling device.

#### **SUPER USER**

The Super User is trained by the Linde Guardian System Expert or EHS Officer and is thereby able to instruct other users of Linde Guardian System.

#### **LINDE GUARDIAN SYSTEM EXPERT (TECHNICIAN)**

The Expert is able to install, configure and maintain the system. The person is trained and certified by KION NA.

#### **EHS OFFICER**

The Environment, Health and Safety Officer is with the company of the users and is doing the risk assessment during the usage of Linde Guardian System.

### Risk Assessment

#### **WARNING**

Risk assessment has to be performed by your Environmental Health and Safety officer.

- In case you do not have an EHS manager, please get in contact with KION NA or your local dealer for further assistance.

Although the Linde Guardian System is an assistance system and the users are still in full responsibility, to assess any potential impact on the company, people, trucks and infrastructure, it is in the company's responsibility to do a risk assessment to utilize the Linde Guardian System.

## Installation report

The installation report is an agreement between the operating company and the service partner (e. g. KION NORTH AMERICA or qualified Resellers).

The report contains all framework conditions plus details of the configuration of the system and any adaptations made to the work environment.

The installation report is distributed as a form along with the technical documents. Once commissioning is complete, the Linde Guardian System is fully documented.

## User report and training

To support users to be aware of the system as an assistance system it is mandatory to:

- 1 Initially train the operator and team about functionality of the system
- 2 Training of at least one super user is mandatory. This can be the EHS or logistics manager. This super user has to be able to train users.
- 3 Training has to be repeated on an annual basis and a test has to be passed by each user (truck driver and pedestrians at the workplace)

## Intended use

The components of the Linde Guardian System have to be used only for their intended purpose. The safety information has to be observed.

### Restricted approval for use

#### **WARNING**

Linde Guardian System is approved for use in the United States of America, Canada and Mexico.

Use in other countries is not authorized by Linde Material Handling nor KION NORTH AMERICA.

### General

The Linde Guardian System is a wireless assistance system for informing pedestrians and forklift truck drivers in defined areas in industrial environments.

The truck and mobile components of Linde Guardian System can generally be used inside and outside.



#### **NOTE**

*The use of devices mounted on outdoor structures, e. g. Static Units mounted on the outside of a building or any fixed outdoor infrastructure is prohibited.*

## Limitations for commissioning or for the permission to operate

If radio frequency interference at the place of use results in adjustments to suit local conditions, re-registration and approval may be necessary.

### Usage

The components of the Linde Guardian System are used in the working environment of industrial trucks.

The system wirelessly measures the distance between the component mounted on the industrial truck, components at fixed positions in the working area and the mobile components that individuals carry on their person.

#### WARNING

It is prohibited to use the Linde Guardian System as a guide when visibility is poor.

### Installation

The installation of Linde Guardian System has been fulfilled by a qualified and authorized service technician. After the installation, the system has to be configured and tested for functionality. This test has to be documented and signed by the technician and the EHS Manager of your company.

#### WARNING

It is prohibited to install the Linde Guardian System with a non-authorized service technician.

The components on the industrial truck are permanently connected to the on-board elec-

tronics. Only authorized service technicians with electrical knowledge and the relevant experience are permitted to install components at fixed points in the working area and to carry out servicing work and repairs. Usually, the persons that install the fixed components are not KION NA service technicians, but electricians.

### Environment

The Linde Guardian System has to be tested by the service technician at the place of use. Incorrect installation or other wireless networks can cause malfunctions.



#### NOTE

*Only the approved service partner is permitted to make adjustments to suit local conditions in the event of radio frequency interference. In this situation, it may be necessary to register and obtain approval again.*

### Wireless Spectrum Site Survey

#### WARNING

Carry out a functional test in the target environment covering all aspects of the installation. It is the responsibility of the applying company to analyze the radio spectrum in regular time intervals and especially if new wireless systems are activated.

The survey must show that the frequency band at which the Linde Guardian System will operate is free from external interferences.

Radio interference in the same spectrum may result in a malfunction of Linde Guardian System.

## Limitations for commissioning or for the permission to operate

This user guide belongs to the Linde Guardian System. It contains important notes for the initial operation and correct operation/use of the system. Review and follow all instructions prior to operation and keep this guide for future reference.

### FCC and ISED regulatory specification

This equipment has been tested and found to comply with the limits of a Class B digital device, pursuant to Part 15 of the FCC Rules. These limits are designed to provide reasonable protection against harmful interference in a

residential installation. This equipment generates, uses and can radiate radio frequency energy and, if not installed and used in accordance with the instructions, may cause harmful interference to radio communications.

### WARNING

There is no guarantee that interference will not occur in an installation.

If this equipment does cause harmful interference to radio or television reception, which can be determined by turning the equipment off and on, the user is encouraged to try to correct the interference by one or more of the following measures:

- Reorient or relocate the receiving antenna
- Increase the separation between the equipment and receiver
- Connect the equipment into an outlet on a circuit different from that to which the receiver is connected
- Consult KION NORTH AMERICA or your qualified reseller for further assistance

## Symbols used

The terms DANGER, WARNING, CAUTION, NOTE and ENVIRONMENT NOTE are used in these operating instructions for notes on particular hazards or for unusual information that needs to be highlighted:

### DANGER

Means that failure to comply can cause risk to life and/or major damage to property.

### WARNING

Means that failure to comply can cause risk of serious injury and/or major damage to property.

### CAUTION

Means that failure to comply can cause risk of material damage or destruction.

## Important Note

Changes or modifications made to this equipment not expressly approved by KION NORTH AMERICA or its authorized reseller respectively WILL void the FCC authorization to operate this equipment.

### NOTE

*The use of devices mounted on outdoor structures, e. g. Static Units mounted on the outside of a building or any fixed outdoor infrastructure is prohibited.*

Only handheld devices may be used in mobile scenarios in mixed in-/outdoor mode. For example, Truck Unit together with external sensor nodes, Distance Beeper, Truck Unit Small etc.

### NOTE

*Means that particular attention is drawn to combinations of technical factors which may not be evident even to a specialist.*

### ENVIRONMENT NOTE

*The instructions listed here must be complied with as otherwise environmental damage may result.*



### CAUTION

This label is found on the truck in the areas where particular care and attention are required.

You should refer to the appropriate section in these operating instructions.

For your safety, additional symbols are also used. Please heed the various symbols.



**2**

---

## **Safety**

### Safety information

## Safety information

The operating company has to ensure that all people in the area of application of the Linde Guardian System are informed of its use.

### DANGER

**It is explicitly not a safety system!**

As the Linde Guardian System does not exempt the driver and all people within the workplace from their responsibility and duty of care, drivers and all other people must have to ensure that they are behaving in a safe manner in all situations.

- Always perform a functional test before starting work.

The components of the system must be properly installed and parameterized to ensure that Linde Guardian System works without errors and that the signaling zones are indicated correctly.

Additional acoustic signaling systems and the background noise in the area of operation have to be taken into account when setting the volume level of Linde Guardian System to ensure a good user experience. However, the driver should always observe visually beside the acoustic signals, too.

### WARNING

The unrestricted function of the system is not guaranteed in every operating status imaginable.

Interference can have a negative effect on the system and lead to malfunctions.

Even if there is a malfunction, the driver of the industrial truck has to resolve the situation safely by himself.

### WARNING

The Linde Guardian System functions perfectly up to a speed of 8 mph.

As the speed of industrial trucks that are connected to the system increases, the reaction times of the system and the driver will increase the distance required to decelerate and stop.

### NOTE

*Parameterizing an industrial truck with a speed reduction to 0 mph is prohibited. As a comfort function it must only reduce the speed of the truck to a predefined speedlevel, but never 0 mph.*

### NOTE

*Heavy mechanical stress can lead to malfunctions. In the event of a malfunction signified by smoke or an odor, switch off the industrial truck.*

### NOTE

*The following cases can affect operation:*

- Damage to components of the system
- Extended storage in adverse conditions
- Challenging application conditions

- Contact your service partner.

## Risk assessment

Although the Linde Guardian System is an assistance system and the users are still in full responsibility, to assess any potential impact on the company, people, trucks and infrastructure, it is in the companies responsibility to do a risk assessment to utilize the Linde Guardian System.

It is therefore necessary to adapt the risk assessment in line with national health and safety directives when installing the system. Drivers of industrial trucks with Linde Guardian System and persons with mobile components have to be instructed on the functionality of Linde Guardian System.

The drivers have to familiarize themselves with the operation of an industrial truck in combination with the Linde Guardian System.



**WARNING**

It is in the responsibility of the EHS manager to analyze if there are circumstances that may harm people during the usage of the system e. g.:

Blinking LEDs might cause epileptic seizure.

Heart pump medical devices need to be evaluated in terms of EMC emissions

Furthermore it needs to be analyzed if every user is capable to receive and analyze the signals coming from the devices:

- Problems could be caused by Red/Green weakness

**Risk assessment of driving speed reduction**

In case of entering a signaling zone, the driving speed reduction for the truck can be activated by the service technician. This driving speed reduction serves as a comfort feature for the driver.

**WARNING**

The impact of the reduction of the driving speed on the use of the industrial truck must be analyzed, evaluated and documented in order to arrange additional health and safety measures if necessary.

The driver and any people in the area of operation must not be endangered.

**NOTE**

*Parameterizing an industrial truck with a speed reduction to 0 mph is prohibited. As a comfort function it must only reduce the speed of the truck to a predefined speedlevel, but never 0 mph.*

**Safety during installation**

Installation of Linde Guardian System on the industrial truck is permitted only when the industrial truck is not moving.

**WARNING**

For safety reasons, conversions of or changes to Linde Guardian System are not permitted.

Only authorized service technicians may install, open and connect the components.

**WARNING**

Connections that change the behavior of a third party system, for example a speed reduction of a truck or connections to a door-/gate-control-unit or other third party devices must be done by certified technicians from the third parties.

Only authorized service technicians may install, open and connect the components.

**WARNING**

The stationary components may be installed, opened and connected only when the system is not connected to the power supply.

- Disconnect devices from power supply during installation.

**WARNING**

All devices have to be installed fully and properly.

- Install all devices with the proper covers.
- Make sure that seals and screws are properly seated.

**NOTE**

*Only qualified electricians are permitted to install, open and modify Static Units. This means that authorized service technicians are usually not allowed to perform electrical installations on 120 VAC power supplies. This kind of installations have to be done by qualified licensed electricians.*

The equipment has to be checked after these actions.

Check the local main voltage before commissioning. The permissible system voltage range has to be in line with the local main voltage.

### General safety instructions

## General safety instructions

### WARNING

The water content of the human body can influence radio signals, either preventing or limiting the function of Linde Guardian System. Hence, a malfunction may occur due to radio frequency signal disruption.

- Wear the Distance Beeper high on your body.
- Wear the Distance Beeper such that it is unobstructed.
- Always check that Linde Guardian System is working before starting work.
- The attention of all participants to the surroundings must always be maintained.

### DANGER

**Radio frequency radiation is released due to the use of Linde Guardian System.**

- Other devices could be disturbed and, hence, their function may be impaired.
- If applicable, check with the manufacturer of pacemakers or other medical devices, whether disturbance cannot be excluded.

### DANGER

**Touching live parts can result in injuries or death! This can also be aggravated by the fact that some components run on 120 VAC. Also a short circuit can occur which causes components to be heated. This can lead to injuries.**

Never open the housings when devices are connected to the power supply. Changes or modifications made to this equipment not expressly approved by KION NORTH AMERICA or its authorized reseller respectively will void the FCC authorization to operate this equipment.

- Disconnect the power supply before working on electrical components.
- Remove metal objects such as rings or watches beforehand.
- Connection, testing and measuring work on electrical parts may only be carried out by a qualified electrician (cf. section Safety Information).
- Only qualified electrician may open the housing of the respective device in consultation with KION NORTH AMERICA.
- If the electrical parts are faulty or damaged, turn off the electrical power supply immediately and initiate repair.
- The regulations of the local energy supplier must be complied with.

### DANGER

**The Linde Guardian System offers a muting function for the forklift truck driver's pedestrian tag. Note that a different person than the driver can mute his pedestrian tag. Especially, if vehicle muting zone is too large.**

A risk assessment must be performed by the EHS manager to analyze if there are circumstances that may harm people during the usage of the system (cf. section Safety Information).

### WARNING

Conductive materials in the radio link line between transmitter and receiver, such as metals, liquids, human bodies, etc., can cause the system to fail completely.

A risk assessment must be performed by the EHS manager to analyze if there are circumstances that may harm people during the usage of the system (cf. section Safety Information).

### DANGER

**The Linde Guardian System devices are electrical components and, hence, can cause sparks, which could ignite dust, gases or vapours. Switching sparks can occur when the on/off switch is operated, when it is removed from the charger or when internal relays are switched etc. Therefore, the Linde Guardian System is not certified for explosion hazard environments. Potentially explosive environments (EX) are environments where flammable liquids (vapours), gases or dusts are found.**

- Never operate Linde Guardian System in a potentially explosive environment!

### WARNING

Although the Linde Guardian System devices are partially IP tested, they are not completely waterproof. As Linde Guardian System devices are electrical components, contact with water can cause short circuits and should therefore be avoided.

- Protect Linde Guardian System devices from contact with water.

**WARNING**

Incorrect handling of the charger and the pedestrian tag can lead to hazardous situations.

The following points must be noted:

- Only plug the electric cable into an officially approved socket.
- After the charger has been used, always disconnect the plug from mains supply.
- Ensure that the Linde Guardian System pedestrian tag is not exposed to direct sunlight, heat, open fire or electric sparks.
- Never expose the pedestrian module to micro-waves or high pressure.
- Never throw Linde Guardian System devices into fire.

**Service personnel**

Any work to exchange, align and set components of Linde Guardian System and to make adaptations to the industrial truck must be performed by trained and authorized service personnel.

The authorized service technician must have specialist knowledge in the field of industrial trucks. In addition, they must have specific system knowledge of the Linde Guardian System and the relevant training.

For installing infrastructure nodes, e. g. Static Unit which use a main power supply, the per-

- Never charge or use a defective, damaged or deformed pedestrian module.
- Never open, damage or drop the Linde Guardian System devices.

**WARNING**

Fire hazard!

- Do not use the charger on a readily combustible surface (e.g. paper, textiles), or in a readily combustible environment.
- Disconnect the plug immediately from mains supply if the charger catches fire or emits smoke.
- Do not cover the charger to allow it to cool without hindrance.

mission by law and profound knowledge in terms of electrical installations is required.

Hence, these tasks must be performed by qualified licensed electricians. Usually, fork lift truck service technicians do not have this required knowledge and are, hence, not allowed to do installations of fixed components or only if they are qualified to do so.

- Contact your authorized service partner.

# **3**

---

## **Operating devices and display elements**



#### Overview

#### Overview

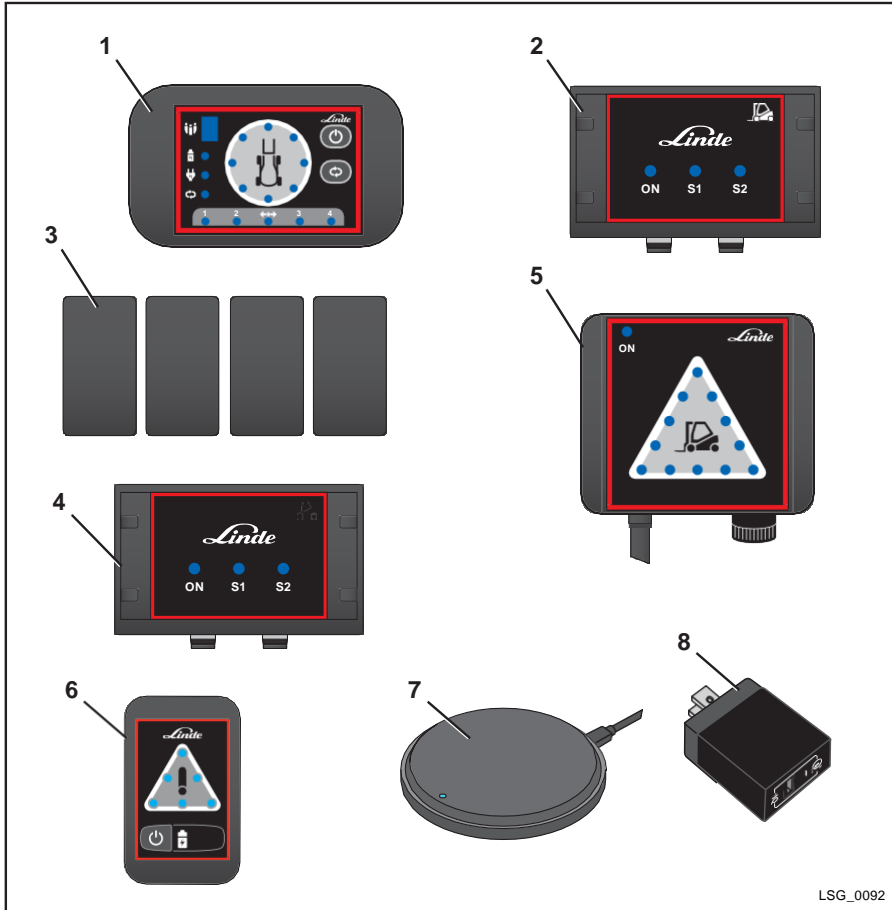

LSG\_0092

- 1 Truck Unit
- 2 Truck Unit Small
- 3 Sensor Truck Unit (1-5 possible)
- 4 Zone Marker

- 5 Static unit
- 6 Distance Beeper
- 7 Inductive Charger
- 8 Power Plug for Inductive Charger

## Truck Unit

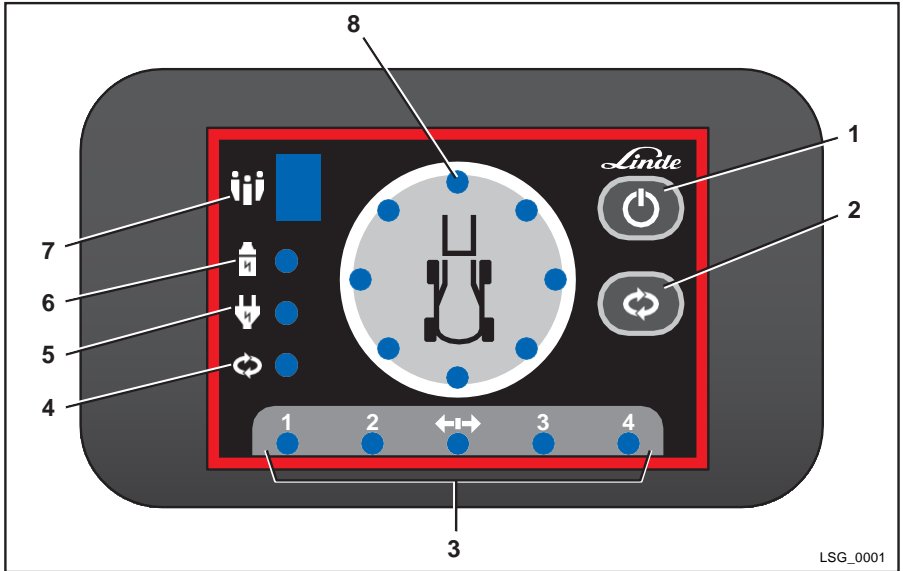

- |   |                                    |   |                                         |
|---|------------------------------------|---|-----------------------------------------|
| 1 | No function                        | 5 | Power supply                            |
| 2 | No function                        | 6 | No function                             |
| 3 | Sensors, switching output (middle) | 7 | Number of persons in the signaling zone |
| 4 | Pairing active                     | 8 | Signaling zones                         |

The Truck Unit provides the driver of the industrial truck with an acoustic and visual signaling whenever he approaches certain areas or pedestrians. These areas and/or pedestrians also have to be equipped with the Linde Guardian System. LEDs indicate the number, direction, and distance to these areas / pedestrians. The same can also be realized when the driver is entering areas in which he should reduce the speed.

The driver also receives information about the status of the sensors, the switching output and whether signaling Distance Beepers are paired with the Truck Unit.

The Truck Unit responds to the following components:

- Distance Beeper
- Static Unit
- Zone Marker
  
- Truck Unit Small
- Truck Unit



### Sensors, switching output (middle) ▷

The LEDs 1 to 4 indicate the status of the sensors.

The following operating statuses are possible:

- LED green:

The Truck Unit is switching on. The sensors perform self-testing for 10 seconds.

- LED off:

The Truck Unit is switched on. The sensors are ready for operation.

- LED red:

The Truck Unit is switched on but the respective sensor is not ready for operation. Stop operation. Check the sensor.

The middle LED displays the status of the switching output.

The following operating statuses are possible:

- LED green:

Switching on or changing the switching output from active to inactive.

- LED off:

Switching output inactive.

- LED red:

The switching output is active, e.g. indicating that the speed reduction should be active.

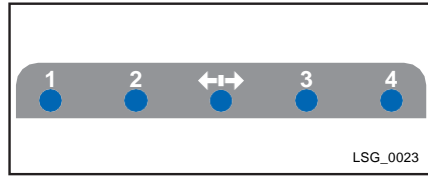

### Pairing active ▷

The LED indicates whether a Distance Beeper is paired with the Truck Unit. No signaling message is triggered for a paired Distance Beeper.

The following operating statuses are possible:

- LED off:

No Distance Beeper is paired.

- LED green:

Distance Beeper is paired and within range of the Truck Unit.

- LED red:

Distance Beeper is paired but not within range of the Truck Unit.

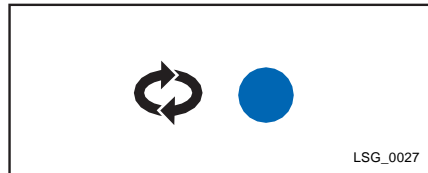

#### Power supply

The LED indicates the operating status of the Truck Unit:

- LED flashes green:  
Truck Unit is ready for operation.
- LED flashes red:  
The Truck Unit has registered an error.

The Truck Unit is in programming mode.

- LED lights up red:  
The Truck Unit has registered an error.
- The Truck Unit is in programming mode.

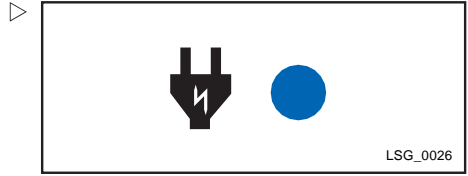

#### Number of persons in the signaling zone

The display indicates the number of people in the signaling zone. The display ranges from 0 - 9 people. If the display flashes, there are more than nine (9) people in the signaling zone.



#### Signaling zones

The LEDs for the signaling zones indicate whether there are people in one of the signaling zones. If there are people in the signaling zone, the LEDs flash in a constant rhythm.

The following operating statuses are possible:

- Three LEDs flash red:

A person is in the extended area. The LEDs indicate the direction from which the person is approaching.

- Three LEDs flash orange:

An industrial truck with a truck-to-truck sensor or a communication unit is located in the extended area. The LEDs indicate the direction from which the industrial truck is approaching.

- Multiple LEDs flash red:

There are several people in the extended area. The LEDs indicate the direction from which the people are approaching.

This function must be switched on in the configurator.

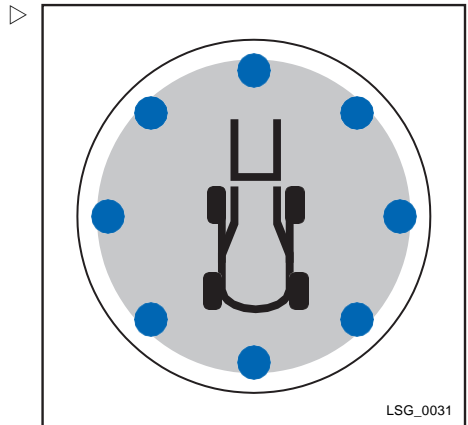

**NOTE**

*This function must be switched on in the configurator.*

- Multiple LEDs flash orange:

There are several industrial trucks in the extended area. The LEDs indicate the direction from which the industrial trucks are approaching.

This function must be switched on in the configurator.

**NOTE**

*This function must be switched on in the configurator.*

- All LEDs flash red:

There are several people in the extended area. The direction is not displayed.

There are one or more people in the vicinity.

The industrial truck is in the signaling zone for a cone.

- All LEDs flash orange:

There are several industrial trucks in the extended area. The direction is not displayed.

There are one or more industrial trucks in the vicinity.

- Four LEDs flash orange:

No driver is sitting on the driver's seat. Pairing of a signaling Distance Beeper is active.

**NOTE**

*If a dual signal is received regarding an industrial truck and a person at the same time, a mixed display is shown. The signaling regarding a person takes priority on the display. If people and industrial trucks are approaching from the same direction, the LEDs only flash red; the number of LEDs is displayed correctly.*

### Optional Speed reduction as comfort function via potential-free outputs

The Truck Unit is intended to inform the driver through giving optical and/or acoustic signals or optionally an automatic reduction in the driving speed as a comfort function in defined Zone Marker or Static Unit areas, when approaching pedestrians equipped with Distance Bleepers and through truck-to-truck signals.

#### A KION NA trucks

The installing of the optional speed reduction as comfort function must be performed by a certified and approved service-technician on approved KION NA trucks. KION NA maintains and provides a specific list including all approved vehicles for the optional speed reduction as comfort function. Furthermore, if this optional modification is performed, the applying company must do a risk assessment to utilize the Linde Guardian System.

#### B Third-party forklift trucks

In case if the potential free outputs of the truck unit should be connected to any third-party truck, the manufacturer of the truck must have approved the truck inputs for this purpose. As in the previous case, the installation must be carried out by a certified and approved service technician. Furthermore, if this optional modification is performed, the applying company must do a risk assessment to utilize the Linde Guardian System.



#### NOTE

*The installation of the speed reduction as comfort function option is part of the Linde service-technician training in the framework of the Linde Guardian System and depends on the respective model. So also consider the information of the Linde Service Guide (LSG) for the model that you want to equip with the speed reduction as comfort function option.*

## Truck Unit 2

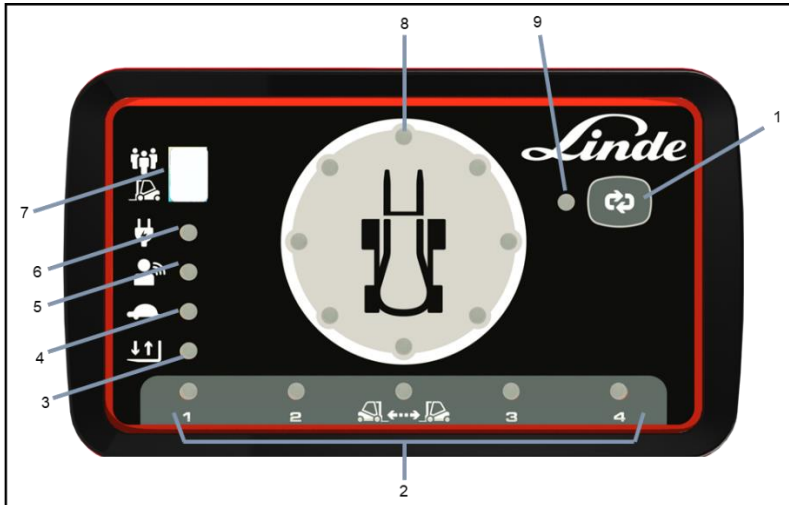

- |   |                                    |   |                                         |
|---|------------------------------------|---|-----------------------------------------|
| 1 | No function                        | 5 | Pairing active                          |
| 2 | Sensors, switching output (middle) | 6 | Power supply                            |
| 3 | Mast lift height sensor            | 7 | Number of persons in the signaling zone |
| 4 | Speed reduction                    | 8 | Signaling zone                          |
|   |                                    | 9 | Light Sensor                            |

The Truck Unit provides the driver of the industrial truck with an acoustic and visual signaling whenever he approaches certain areas or pedestrians. These areas and/or pedestrians also have to be equipped with the Linde Guardian System. LEDs indicate the number, direction, and distance to these areas / pedestrians. The same can also be realized when the driver is entering areas in which he should reduce the speed. The driver also receives information about the status of the sensors, the switching output and whether signaling Distance Beepers are paired with the Truck Unit. Furthermore, the driver receives information about the status of the mast height detection which may lead to speed reduction in certain areas with height limitations.

### 3 Operating devices and display elements



The Truck Unit responds to the following components:

- Distance Beeper
- Static Unit
- Zone Marker
- Truck Unit Small
- Truck Unit

#### Sensors

The LEDs 1 to 4 indicate the status of the sensors.

The following operating statuses are possible:

- LED green:

The Truck Unit is switching on. The sensors perform self-testing for 10 seconds.



- LED off:

The Truck Unit is switched on. The sensors are ready for operation.

- LED red:

The Truck Unit is switched on, but the respective sensor is not ready for operation. Stop operation. Check the sensor.

#### Speed Reduction Active

The LED indicates, the status of the speed reduction.

The following operating statuses are possible:

- LED green:

Switching the speed reduction from active to inactive.



- LED off:

Speed reduction inactive.

- LED red:

The speed reduction is active.

## Pairing active

The LED indicates whether a Distance Beeper is paired with the Truck Unit. No signaling message is triggered for a paired Distance Beeper.

The following operating statuses are possible:

- LED off:  
 No Distance Beeper is paired.

- LED green:  
 Distance Beeper is paired and within range of the Truck Unit.

- LED red:  
 Distance Beeper is paired but not within range of the Truck Unit.



## Power supply

The LED indicates the operating status of the Truck Unit:

- LED flashes green:  
 Truck Unit is ready for operation.
- LED flashes red:  
 The Truck Unit has registered an error. The Truck Unit is in programming mode.
- LED lights up red:  
 The Truck Unit has registered an error. The Truck Unit is in programming mode.



## Mast Height detection

The LED indicates the status of the mast height sensor.

The following operating statuses are possible:

- LED off:  
Mast height sensor is not triggered.

- LED green:  
Mast height sensor is switched from active to inactive.

- LED red:  
Mast height sensor is triggered.



## Number of persons in the signaling zone

The display indicates the number of people/forklifts in the signaling zone. The display ranges from 0 - 9 objects. If the display flashes, there are more than nine (9) objects in the signaling zone.



## Signaling zones

The LEDs for the signaling zones indicate whether there are people in one of the signaling zones. If there are people in the signaling zone, the LEDs flash in a constant rhythm.

The following operating statuses are possible:

- Three LEDs flash red:

A person is in the extended area. The LEDs indicate the direction from which the person is approaching.

- Three LEDs flash orange:

An industrial truck with a truck-to-truck sensor or a communication unit is located in the extended area. The LEDs indicate the direction from which the industrial truck is approaching.

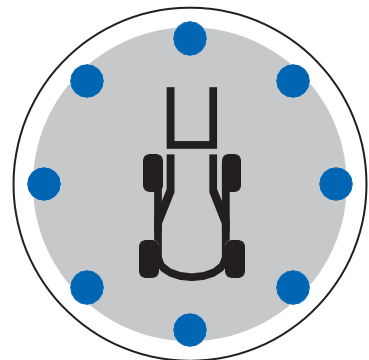

- Multiple LEDs flash red:



There are several people in the extended area.  
The LEDs indicate the direction from which the people are approaching.

This function must be switched on in the configurator.

## Truck Unit Small

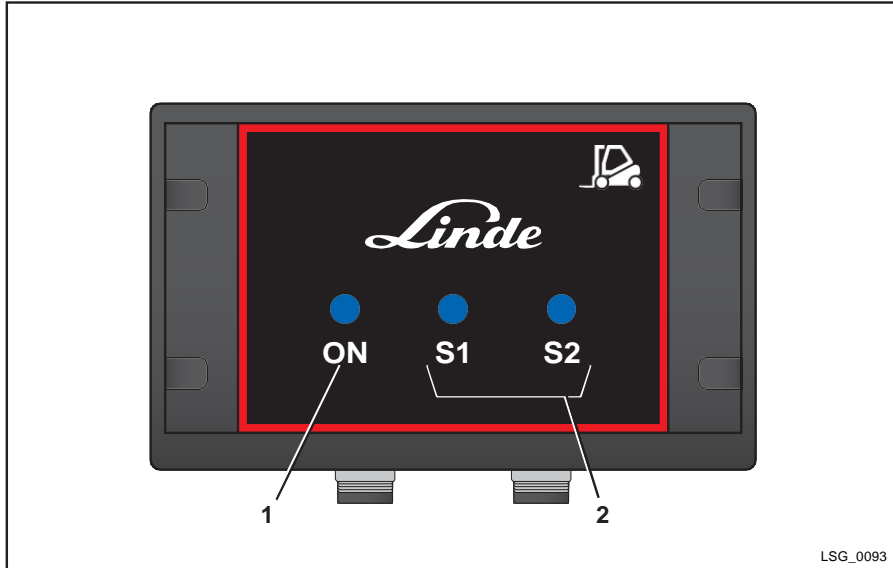

1 Operating status

2 Signaling zones

The Truck Unit Small is intended to reduce risks through either giving optical signals or optionally an automatic reduction in the driving speed in defined Zone Marker or Static Unit areas and through truck-to-truck signals.

#### NOTE

*The Truck Unit Small does not provide signals about people approaching with a Distance Beeper.*

The Truck Unit Small responds to the following components:

- Static Unit
- Zone Marker
- Truck Unit Small or Truck Unit with truck-to-truck sensor

### Truck Unit Small

The "ON" LED indicates the operating status of the Truck Unit Small:

- LED flashes green:

The Truck Unit Small is ready for operation.

- LED red / flashes red:

The Truck Unit Small is signaling an error.

The "S1" and "S2" LEDs indicate whether the industrial truck is located in a static signaling zone.

- LEDs flash orange:

Radio module or Static Unit in the extended area of the industrial truck.

Truck-to-truck signaling in the extended area.

- LEDs flash red:

Radio module or Static Unit in the vicinity of the industrial truck.

Truck-to-truck signaling at close range

- LEDs off:

No signaling zone detected



#### Optional Speed reduction as comfort function via potential-free outputs

The Truck Unit is intended to inform the driver through giving optical and/or acoustic signals or optionally an automatic reduction in the driving speed as a comfort function in defined Zone Marker or Static Unit areas, when approaching pedestrians equipped with Distance BEEPERS and through truck-to-truck signals.

##### A KION NA trucks

The installing of the optional speed reduction as comfort function must be performed by a certified and approved service-technician on approved KION NA trucks. KION NA maintains and provides a specific list including all approved vehicles for the optional speed reduction as comfort function. Furthermore, if this optional modification is performed, the applying company must do a risk assessment to utilize the Linde Guardian System.

##### B Third-party forklift trucks

In case if the potential free outputs of the truck unit small should be connected to any third-party truck, the manufacturer of the truck must have approved the truck inputs for this purpose. As in the previous case, the installation must be carried out by a certified and approved service technician. Furthermore, if this optional modification is performed, the applying company must do a risk assessment to utilize the Linde Guardian System.



#### NOTE

*The installation of the speed reduction as comfort function option is part of the Linde service-technician training in the framework of the Linde Guardian System and depends on the respective model. So also consider the information of the Linde Service Guide (LSG) for the model that you want to equip with the speed reduction as comfort function option.*

## Truck Unit Small 2

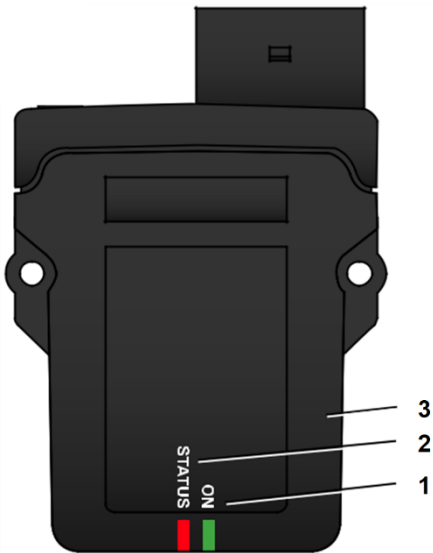

- 1 Operating status
- 2 Signaling zones
- 3 Truck Unit Small 2

The Truck Unit Small is intended to reduce risks through either giving optical signals or optionally an automatic reduction in the driving speed in defined Zone Marker or Static Unit areas and through truck-to-truck signals.

### NOTE

*The Truck Unit Small does not provide signals about people approaching with a Distance Beeper.*

The Truck Unit Small responds to the following components:

- Static Unit
- Zone Marker
- Truck Unit Small or Truck Unit with truck-to-truck warning active

The "ON" LED indicates the operating status of the Truck Unit Small:



LED flashes green quickly:

- The Truck Unit Small is ready for operation.

LED flashes green slowly:

- The Truck Unit Small is not configured.

LED flashes blue

- The Truck Unit Small is in ZI Mode

LED red / flashes red:

- The Truck Unit Small is signaling an error.

The "Status" LED indicates whether the industrial truck is located in a static signaling zone or a speed reduction is activated.



LED flashes blue:

- Radio module or Static Unit in the extended area of the industrial truck.
- Truck-to-truck signaling in the extended area.

LED constantly blue

- Device deactivated/muted

LEDs flashes red:

- Radio module or Static Unit in the vicinity of the industrial truck.
- Truck-to-truck signaling at close range
- External Input active

LED constantly red

- Speed reduction activated

LEDs off:

- No signaling zone detected

## Optional Speed reduction as comfort function via potential-free outputs

The Truck Unit Small is intended to inform the driver through giving optical and/or acoustic signals or optionally an automatic reduction in the driving speed as a comfort function in defined Zone Marker or Static Unit areas, when approaching pedestrians equipped with Distance BEEPERS and through truck-to-truck signals.

### A KION NA trucks

The installing of the optional speed reduction as comfort function must be performed by a certified and approved service-technician on approved KION NA trucks. KION NA maintains and provides a specific list including all approved vehicles for the optional speed reduction as comfort function. Furthermore, if this optional modification is performed, the applying company must do a risk assessment to utilize the Linde Guardian System.

### B Third-party forklift trucks

In case if the potential free outputs of the truck unit small should be connected to any third-party truck, the manufacturer of the truck must have approved the truck inputs for this purpose. As in the previous case, the installation must be carried out by a certified and approved service technician. Furthermore, if this optional modification is performed, the applying company must do a risk assessment to utilize the Linde Guardian System.



#### NOTE

*The installation of the speed reduction as comfort function option is part of the Linde service-technician training in the framework of the Linde Guardian System and depends on the respective model. So also consider the information of the Linde Service Guide (LSG) for the model that you want to equip with the speed reduction as comfort function option.*

## Distance Beeper

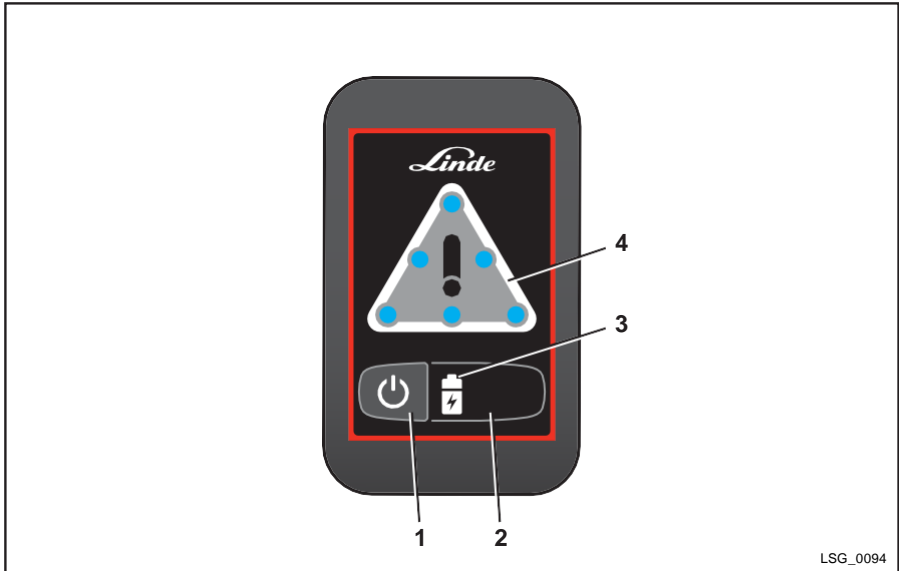

LSG\_0094

1 Switch on  
2 No function

3 Rechargeable battery charge state  
4 Signaling zone

The Distance Beeper provides the pedestrian with an audible, visual and tactile signal.

The Distance Beeper responds to the following components:

- Truck Unit
- optionally Static Unit
- optionally Zone Marker

### CAUTION

Lithium-ion battery destroyed as a result of deep discharge.

Do not store the Distance Beeper for more than one year. Charge the Distance Beeper after one year.



## Switching on

You can use the "switch on / switch off" push button to switch the Distance Beeper on and off. To switch on the unit, push and hold the push button until the Distance Beeper starts up. The unit vibrates as it is switched on. A feedback tone sounds.

To switch off the unit, push and hold the push button until the Distance Beeper shuts down.

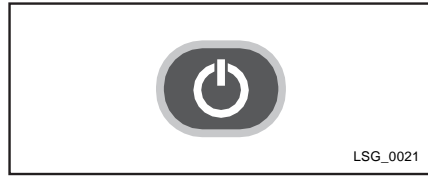

## Rechargeable battery charge state

The LED indicates the operating status and the charge state of the Distance Beeper.

The following operating statuses are possible:

- LED off:

The Distance Beeper is switched off

- LED flashes green:

The Distance Beeper is switched on. The charge state is more than 20% of the total capacity.

- LED flashes red:

The Distance Beeper is switched on. The charge state is less than 20% of the total capacity. A periodic signal sound is also emitted.



### NOTE

*The Distance Beeper can only be recharged at temperatures above 0 °C (+32 °F).*

### WARNING

The battery of the Distance Beeper can be damaged due to extreme temperature conditions.

- Make sure that direct sunlight and heat exposure is avoided.
- Store the Distance Beeper above 0 °C (+32 °F).

#### Signaling zone

The LEDs of the signaling zone indicate whether the person is located in the signaling zone of an industrial truck. The LEDs flash. In addition, the Distance Beeper vibrates and emits an acoustic signal. The frequency and duration of the signal is dependent on the configuration of the Truck Unit.

If a Static Unit is configured as a "relay station", the Distance Beeper provides a signal when entering this zone ahead of industrial trucks in the zone.

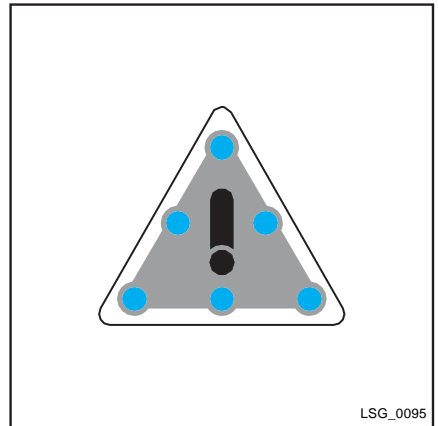

## Charging station

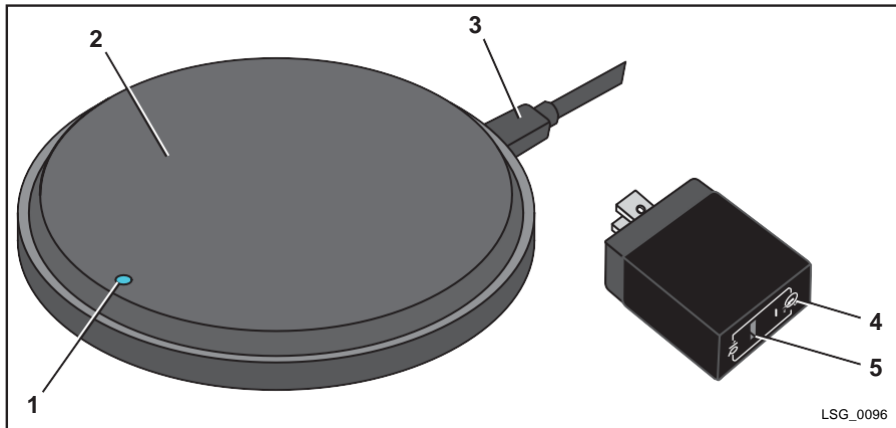

- |   |                  |   |                                         |
|---|------------------|---|-----------------------------------------|
| 1 | Charge indicator | 4 | Status display of the power supply unit |
| 2 | Charging area    | 5 | USB port                                |
| 3 | Mini USB cable   |   |                                         |

The inductive charging station charges the Distance Beepers. To charge a Distance Beeper, place it on the charging area (2). The charging station is connected to the power supply unit using a mini USB cable (3) via the corresponding port (5).

The following components can be charged:

- Distance Beeper

### Charge indicator

- The LED (1) lights up for 3 seconds:

The charging unit is connected to a power supply.

- The LED lights up blue:

Active charging process for a Distance Beeper

- The LED flashes up blue  
Abnormal objects detected.
- The LED flashes green:

The charging station indicates an overvoltage protection.

#### **Status display of the power supply unit**

- LED (4) lights up green:  
The power supply unit is connected to the power supply and is ready for operation

## Sensor Truck Unit

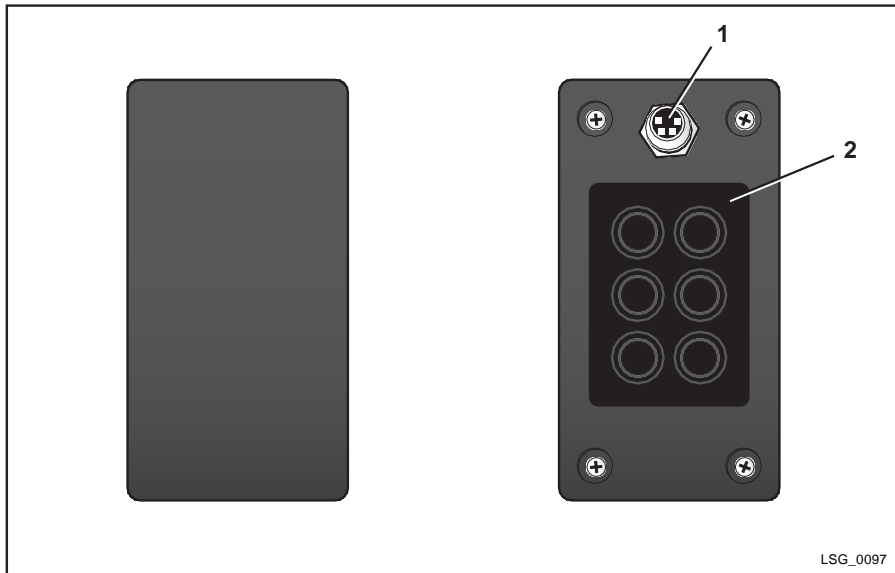

1 Connection

2 Mounting magnet

The Sensors are mounted on the industrial truck and connected to the Truck Unit. The Sensors create the signaling zones around the industrial truck. The Sensor does not fit to the Truck Unit Small. The installation shall be accomplished by a trained technician. It is important to install the antennas free of obstructions.

### Connection

To connect the Sensor to the Truck Unit

### Mounting magnet

Mount the Sensors magnetically to the industrial truck.

### MAC address

The position of the Sensors is stored on the Truck Unit via the MAC address.

## Static Unit

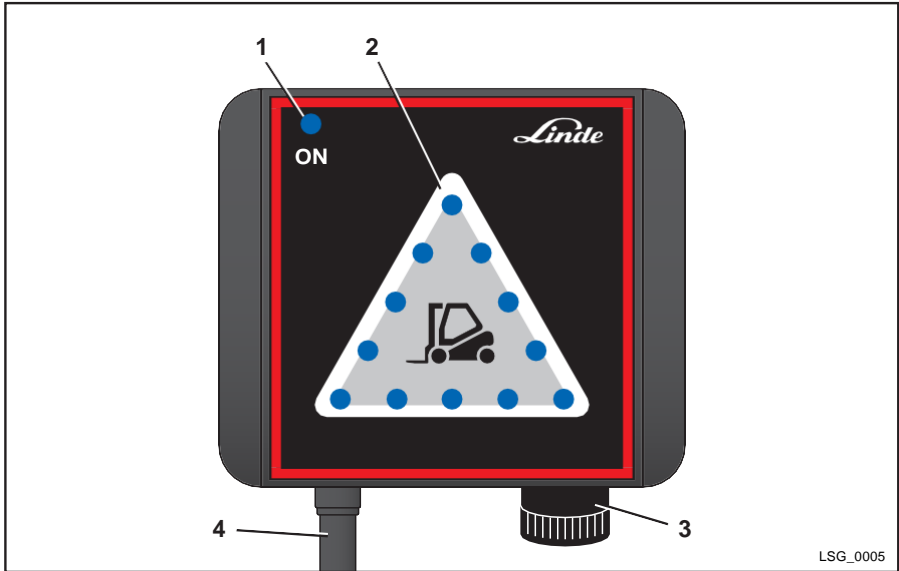

1 Operating status  
2 Signaling zone

3 Acoustic signal transmitter  
4 Power supply

The Static Unit is an infrastructure unit. The Static Unit provides acoustic and visual signals regarding pedestrians and industrial trucks.

The Static Unit is used at blind spots or in the event of poor radio communication.

The Static Unit offers the following additional functions:

- Speed reduction on the industrial truck
- Lift height detection
- Outputs for activating external signalling devices

The Static Unit responds to the following components:

- Truck Unit
- Truck Unit Small
- Distance Beeper

### Operating status

The LED indicates the operating status of the Static Unit.

The following operating statuses are possible:

- LED off:

The Static Unit is not connected to the power supply.

- LED flashes green:

The Static Unit is ready for operation.

- LED flashes red:

The Static Unit is signalling an error.

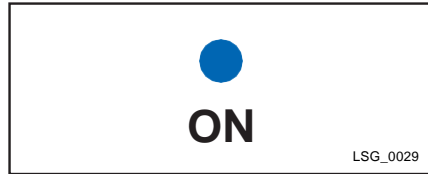

### Signaling zone

The LEDs flash red if industrial trucks with a Truck Unit or a communication unit enter the signaling zone of the Static Unit.

The LEDs flash red if people using a DistanceBeeper enter the signaling zone of the Static Unit.

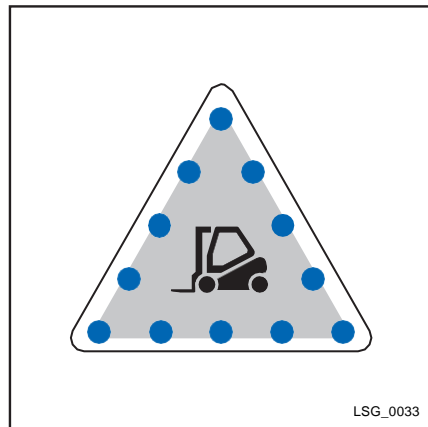

### Acoustic signal transmitter

Depending on the configuration, the acoustic signal transmitter sounds a signal tone as soon as an industrial truck with a Truck Unit or a communication unit enters the signaling zone.

Depending on the configuration, the acoustic signal transmitter sounds a signal tone as soon as a person using a Distance Beeper enters the signaling zone.

### Power supply



#### CAUTION

The Static Unit is supplied with 120 VAC.

Only qualified electricians are permitted to install, open and modify Static Units. This means that authorized service technicians are usually not allowed to perform electrical installations on 120 VAC powersupplies. This kind of installations have to be done by qualified licensed electricians.

### Electrical Outputs via potential-free outputs

The Static Unit outputs must only be used by KION NA certified people.

The outputs are intended for activating or deactivating lights for additional signaling. KION NA provides light-products or third party low-voltage optical signaling-products like LEDs or Flashlights that work with less than 240 V and are allowed to use.

The outputs may only be used to activate or deactivate a relay to which the light-product is connected to.

The installation and wiring must only be executed by certified personal, that are trained and certified to work with electrical current. The safety-standard while working with electrical voltage must be complied with.

#### NOTE

*The usage of the outputs is part of the KION NA service-technician training in the framework of the Linde Guardian System and depends on the respective model.*



## Zone Marker

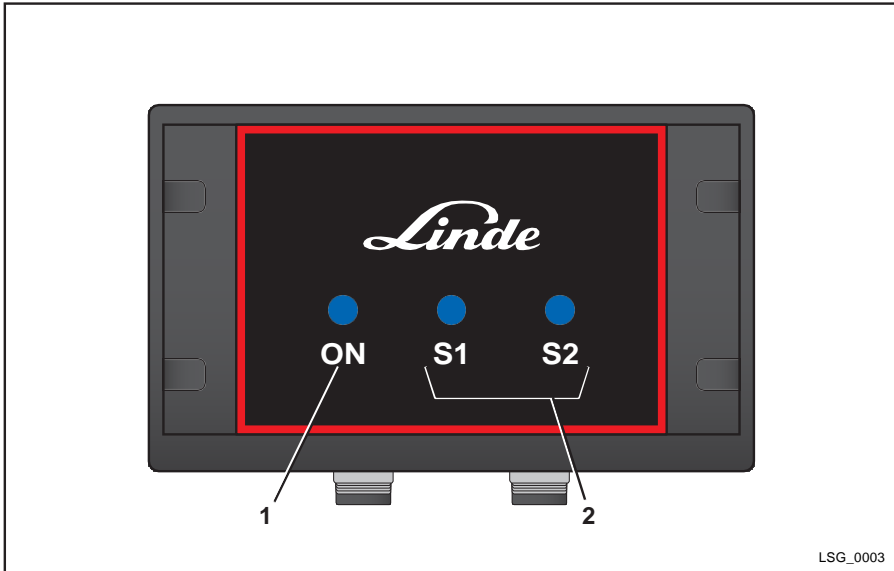

1 Operating status

2 Signaling zones

The Zone Marker creates a stationary signaling zone and triggers further actions on industrial trucks present in this signaling zone. If an industrial truck with a Truck Unit or a Truck Unit Small enters the signaling zone, the ZoneMarker activates, for example, a speed reduction on the industrial truck as comfort function in the corresponding zone around the Zone Marker.

If several Zone Markers are used, it is possible to create larger zones to cover an entire hall area.

The Zone Marker responds and interacts with the following components:

- Truck Unit
- Truck Unit Small

#### Operating status

The LED indicates the operating status of the Zone Marker.

The following operating statuses are possible:

- LED off:

The Zone Marker is not connected to the power supply.

- LED flashes green:

The Zone Marker is ready for operation.

- LED lights up green or red or flashes red: The Zone Marker is signalling an error.

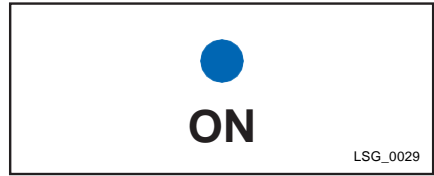

#### Signaling zones

The LEDs flash if industrial trucks with a Truck Unit or a Truck Unit Small are present in the signaling zone of the Zone Marker.

The following operating statuses are possible:

- LEDs flash orange:

Industrial truck in the extended area of the Zone Marker.

- LEDs flash red:

Industrial truck in the vicinity of the Zone Marker.



#### Electrical Outputs via potential-free outputs

The Zone marker outputs must only be used by KION NA certified people. The outputs are intended for activating or deactivating KION light-products or third party low-voltage optical signaling-products like LEDs or Flashlights that work with less than 120 V. The outputs may only be used to activate or deactivate a relay to which the light-product is connected to. The installation and wiring must only be executed by certified personal, which is trained and certified to work with electrical current. The safety-standard while working with electrical voltage must be complied with.



#### NOTE

*The usage of the outputs is part of the KION NA service-technician training in the framework of the Linde Guardian System and depends on the respective model.*

## Zone Marker/PoE Anchor

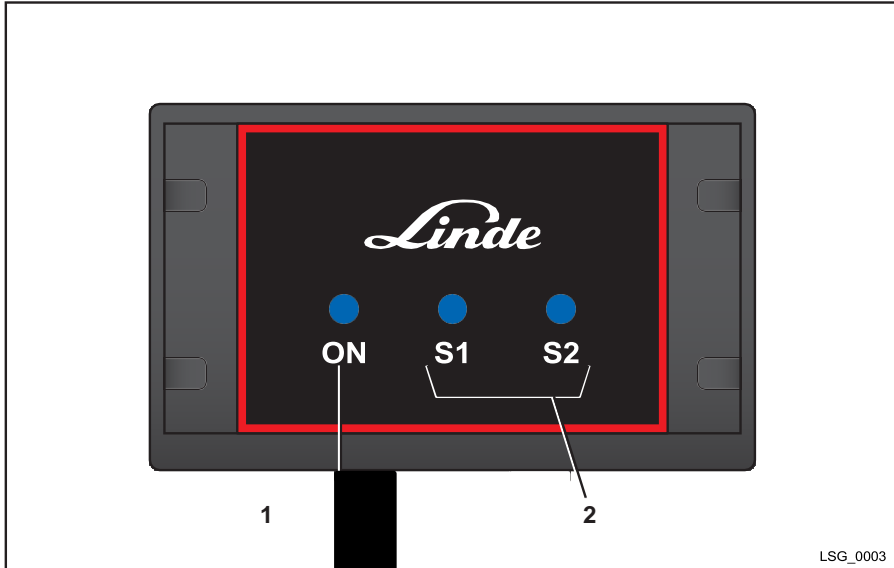

1 Operating status

2 Signaling zones

The PoE Anchor creates a stationary signaling zone and triggers further actions on industrial trucks present in this signaling zone. If an industrial truck with a Truck Unit or a Truck Unit Small enters the signaling zone, the PoE Anchor activates, for example, a speed reduction on the industrial truck as comfort function in the corresponding zone around the PoE Anchor. The PoE Anchor is powered via Power over Ethernet and is able to communicate over Ethernet.

If several PoE Anchors are used, it is possible to create larger zones to cover an entire hall area.

The PoE Anchor responds and interacts with the following components:

- Truck Unit
- Truck Unit Small

#### Operating status

The LED indicates the operating status of the Zone Marker.

The following operating statuses are possible:

- LED off:

The Zone Marker is not connected to the power supply.

- LED flashes green:

The Zone Marker is ready for operation.

- LED lights up green or red or flashes red: The Zone Marker is signalling an error.

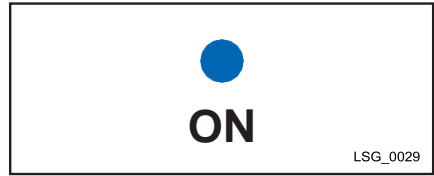

#### Signaling zones

The LEDs flash if industrial trucks with a Truck Unit or a Truck Unit Small are present in the signaling zone of the Zone Marker.

The following operating statuses are possible:

- LEDs flash orange:

Industrial truck in the extended area of the Zone Marker.

- LEDs flash red:

Industrial truck in the vicinity of the Zone Marker.



#### NOTE

*The usage of the outputs is part of the KION NA service-technician training in the framework of the Linde Guardian System and depends on the respective model*

*This equipment may only be operated indoors. Operation outdoors is in violation of 47 U.S.C. 301 and could subject the operator to serious legal penalties.*

## Programmer

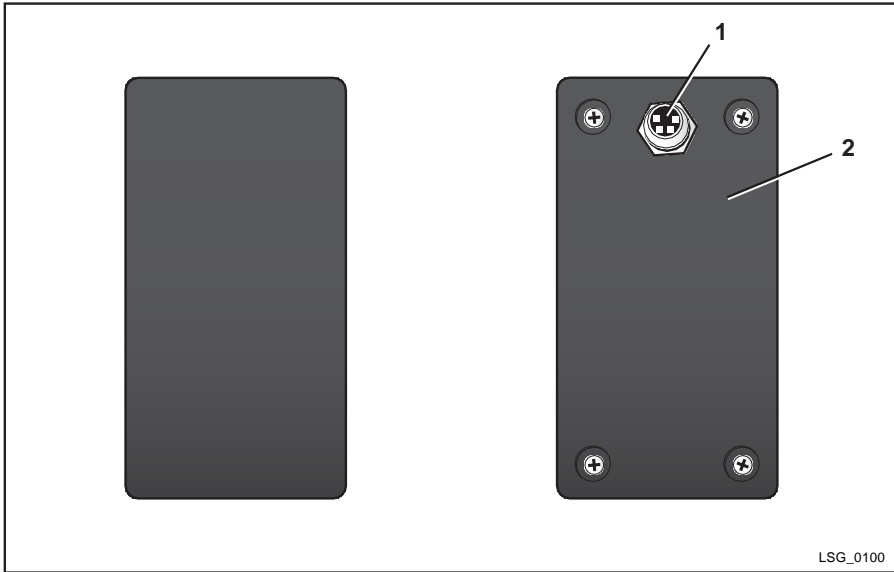

1 4-pole Connection for specific USB cable

2 Housing of device with Label attached

The programmer is not intended to be used by customers. It is intended to be used for either programming or configuring the Linde Guardian System devices. The device is only used by trained service technicians.

#### Connection of the programmer to your PC

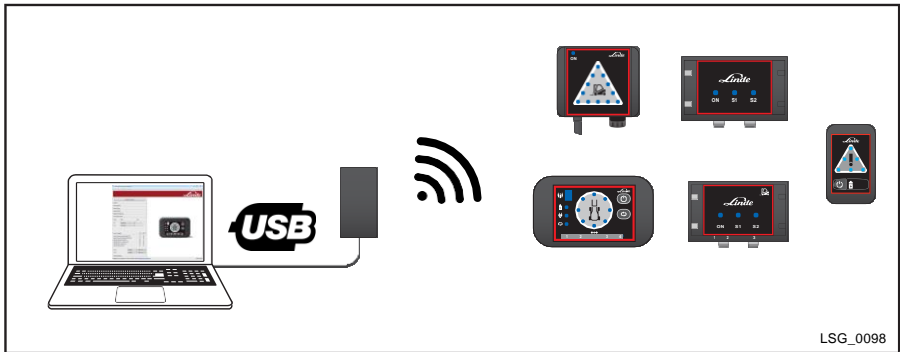

LSG\_0098

Use the additional USB-Cable to connect the programmer to your computer. With the software tool "Wireless Flasher", the programmer enables you to send new firmware to the devices. Furthermore, the provided configuration tool enables the service technician to configure the signaling zones.

#### Wireless Flashing Tool

Start the software via the corresponding \* exe file.

The pop-up window will show up and the tool scans the environment close to you for available units.

- If a device does not appear, click "Rescan for device" to retry.
- Select the device/device(s) by activating the checkbox in the list. Alternatively, hit "All" for selecting all devices shown in the list or "None" for deselecting all devices.
- Click "Transmit firmware" to start transmitting the new firmware versions.

You will be asked for the source folder of the firmware.

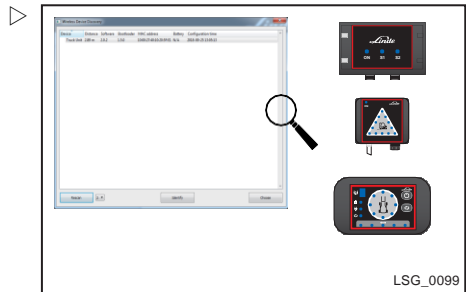

LSG\_0099

**NOTE**

*For configuration possibilities, please refer to the corresponding service-technician training slides that are provided by KION NA. The usage of the software tool is part of the KION NA service-technician training in the framework of the Linde Guardian System and depends on the respective device model and/or fork lift truck model.*

# 4

---

# Operation



## Installation

### Attaching the Distance Beeper

- Switch on the Distance Beeper. To do this, push and hold the push button (2) for one second.

The Distance Beeper starts. A signal tone is heard, the LEDs of the signaling zones light up and the device vibrates briefly.

- Check the charge state of the battery.

The LED must flash green. If the LED flashes red, the Distance Beeper needs charging.

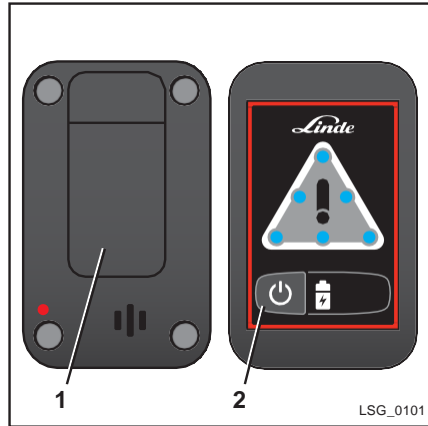

- Attach the Distance Beeper to the outside of your workwear using the clip (1).



### WARNING

Incorrect attachment can lead to incorrect radio communications! Refer to Chapter 4 "Pre-Shift Checks" for details and safeguarding.

- Wear the Distance Beeper high on your body.
- Wear the Distance Beeper such that it is unobstructed.

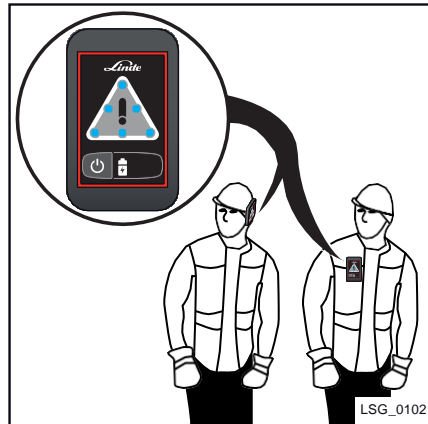

### Installing a Static Unit

The Static Unit is mounted at points that are difficult to see and thus allows the early detection of approaching industrial trucks.

#### NOTE

*Position the Static Unit so that the LED display is easy to see. Install the Static Unit between a height of 2 m (78 inch) but not higher than 7 m (275 inch) in order to guarantee optimal radio coverage. Cf. the Linde service technician training to get yourself more familiar with the correct positioning of the Static Unit devices.*

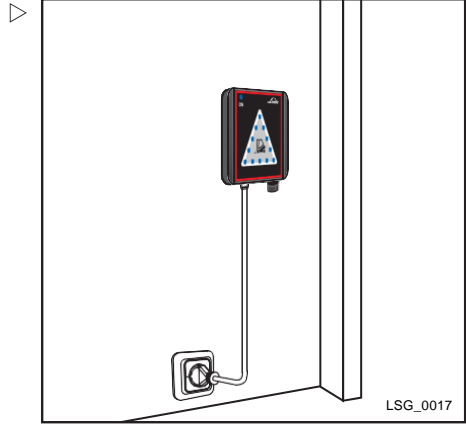

### Installation via magnet

The Static Unit can be mounted to metal surfaces using a magnet.

- Mount a self-adhesive magnet with the sticky side on the rear of the housing.
- Attach the Static Unit in the intended location.
- Connect the Static Unit to the mains connection.

The Static Unit starts and the operating status LED flashes green.

### Installation via screw joint

- To expose the fixing points, open the housing panels(1) at the sides.
- Ensure it is level
- Mark the four fixing points on the ground (2).
- Drill mounting holes and then insert dowels if these are required.
- Mount the Static Unit with four screws and close the housing panels.
- Connect the Static Unit to the mains connection.

The Static Unit starts and the operating status LED flashes green.

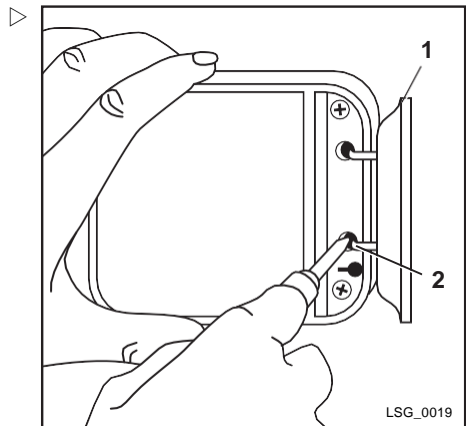

## Installing the Zone Marker

The Zone Marker creates a stationary signaling zone and triggers further actions on industrial trucks present in this signaling zone.

### NOTE

*Install the Zone Marker between a height of 2 m (78 inch) but not higher than 7 m (275 inch) in order to guarantee optimal radio coverage.*

### Installation via magnet

The Zone Marker can be mounted to metallic surfaces using a magnet.

- Mount a self-adhesive magnet with the sticky side on the rear of the housing.
- Attach the Zone Marker in the intended location.
- Connect the Zone Marker to a 12-24-V DC power supply via the connector plug.

The Zone Marker starts and the operating status LED flashes green.

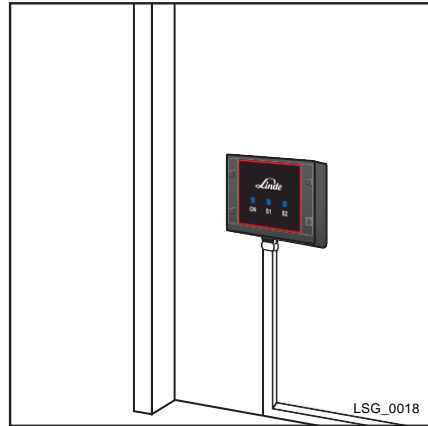

### Installation via screw joint

- Remove the holes cover (1).
- Insert a release tool in the opening (2) and release the upper part of the housing at four points.
- Remove the upper part of the housing.
- Ensure it is level.
- Mark the four fixing points (3) on the ground.
- Drill mounting holes and then insert dowels if these are required.
- Secure the Zone Marker with four screws and attach the upper part of the housing. Make sure that the upper part of the housing engages fully.
- Connect the Zone Marker to a 12-24-V DC power supply.

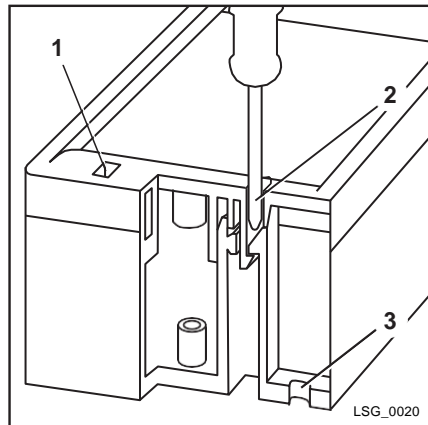

- The Zone Marker starts and the operating status LED flashes green.

## 4 Operation

### Installing the PoE Anchor

The PoE Anchor creates a stationary signaling zone and triggers further actions on industrial trucks present in this signaling zone.



#### NOTE

*Install the PoE Anchor between a height of 2 m (78 inch) but not higher than 7 m (275 inch) in order to guarantee optimal radio coverage.*

#### Installation via magnet

The PoE Anchor can be mounted to metallic surfaces using a magnet.

- Mount a self-adhesive magnet with the sticky side on the rear of the housing.
- Attach the Zone Marker in the intended location.
- Connect the Zone Marker a PoE -Port.

The PoE Anchor starts and the operating status LED flashes green.

#### Installation via screw joint

- Remove the holes cover (1).
- Insert a release tool in the opening (2) and release the upper part of the housing at four points.
- Remove the upper part of the housing.
- Ensure it is level.
- Mark the four fixing points (3) on the ground.
- Drill mounting holes and then insert dowels if these are required.
- Secure the Zone Marker with four screws and attach the upper part of the housing. Make sure that the upper part of the housing engages fully.
- Connect the Zone Marker a PoE -Port.
  - The Zone Marker starts and the operating status LED flashes green.

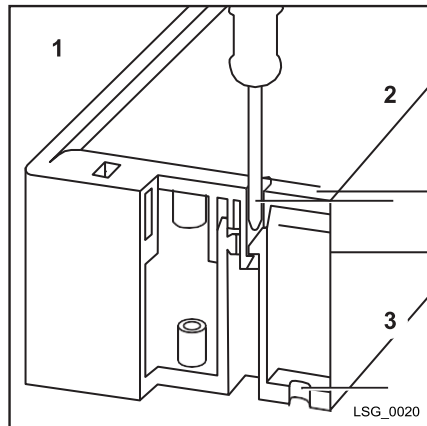
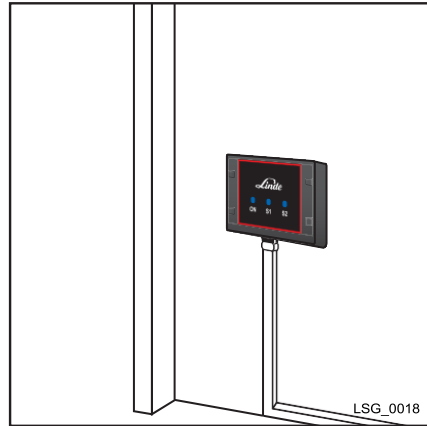

## Pre-shift checks

### Service plan

<b>Distance Beeper</b>
Check the charge state of the battery
Check that the unit is attached to the outside of the clothing
Checking for correct function
<b>Truck Unit</b>
Check for operational readiness
Checking for correct function
Check the pairing with the driver's Distance Beeper
<b>Truck Unit Small</b>
Check for operational readiness
<b>Sensors</b>
Check the mounting and position
Check the connection to the Truck Unit
Check for operational readiness
<b>Static Unit</b>
Check the mounting and position
Housing panels closed?
Checking for correct function
Check that there is an unobstructed view of the Static Unit
<b>Zone Marker</b>
Check the mounting and position
Upper part of housing in place?
Checking for correct function
Check that there is an unobstructed view of the Zone Marker

## Checking the charge state of the Distance Beeper ▷

### WARNING

A discharged battery can reduce the operating time.

➤ Charge the Distance Beeper before use.

➤ Switch on the Distance Beeper.

A short signal tone must be audible and the device must vibrate.

LED (1) continually flashes in green.

➤ If the LED flashes red, charge the Distance Beeper.

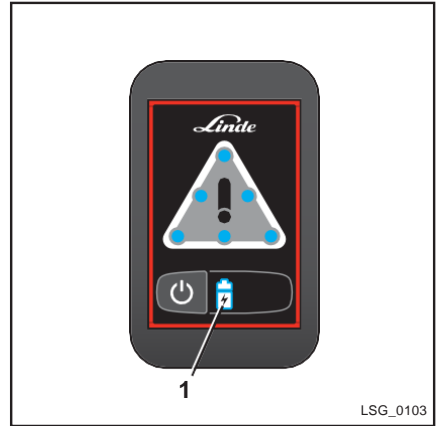

## Checking the function of the Distance Beeper

### WARNING

Due to the radio frequency signal nature of the Linde Guardian System, the functionality of the overall system needs to be checked regularly.

➤ Before the start of work, check the Distance Beeper to ensure that it functions correctly.

➤ Switch on the Distance Beeper and attach the unit to your clothing.

➤ Switch on an industrial truck equipped with the Truck Unit.

The Truck Unit switches on.

➤ With the Distance Beeper attached to your clothing, step into the expanded signaling area of the industrial truck.

## Pre-shift checks

- Circle the truck while remaining within this signaling area.

All the LEDs for the signaling zone flash on the Distance Beeper. A signal tone must sound and the device must vibrate.

The Distance Beeper is now ready to use.



### NOTE

*Alternatively, the pre-shift checks can be performed in conjunction with a Static Unit. The Static Unit must be specially configured for this purpose.*

- Contact your authorized service partner.



## Charging the Distance Beeper

### WARNING

Incorrect handling of the charger and the pedestrian tag can lead to hazardous situations.

The following points must be noted:

- Only plug the electric cable into an officially approved socket.
- After the charger has been used, always disconnect the plug from mains supply.
- Ensure that the Linde Guardian System pedestrian tag is not exposed to direct sunlight, heat, open fire or electric sparks.
- Never expose the pedestrian module to microwaves or high pressure.
- Never throw Linde Guardian System devices into fire.
- Never charge or use a defective, damaged or deformed pedestrian module.
- Never open, damage or drop the Linde Guardian System devices.

#### WARNING

Fire hazard!

- Do not use the charger on a readily combustible surface (e.g. paper, textiles), or in a readily combustible environment.
- Disconnect the plug immediately from mains supply if the charger catches fire or emits smoke.
- Do not cover the charger to allow it to cool without hindrance.

#### WARNING

There is a risk of a mal functioning system due to a discharged battery.

- Always recharge the battery of the Distance Beeper after use.



#### NOTE

*Prior to initial commissioning, the Distance Beeper must be fully charged once. If the Distance Beeper is removed from the charging station too early, the LED flashes red even when the charge capacity is over 90%.*

How to charge the Distance Beeper:

- Connect the power supply unit to the power supply.

The LED on the power supply unit lights up green.

- Connect the charging station to the power supply unit via the USB cable.

The status display lights up red. The charging station is ready for operation.



**Pre-shift checks**

- ▷ Place the Distance Beeper (2) face down on the charging station.

The Distance Beeper emits a signal tone and the LED (3) on the back of the unit flashes red. The charging display (1) on the charging station lights up blue. The charging process starts.

When the charging process is complete, the LED (3) lights up red permanently. The LED on the charging station expires.

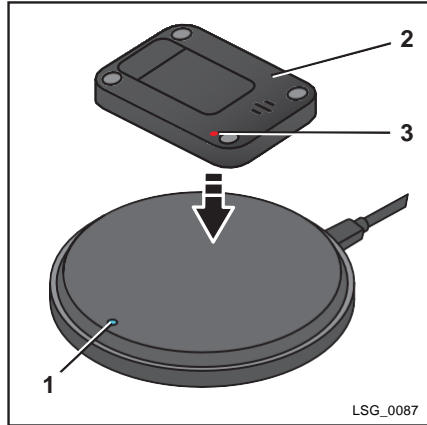
**Checking the operational readiness of the Truck Unit**
**Check for operational readiness**

- ▷ Switch on the industrial truck.
- The Truck Unit switches on and is ready for operation after approx. 15 seconds.
- ▷ Check LED (1) on the Truck Unit.
- The LED must flash green.

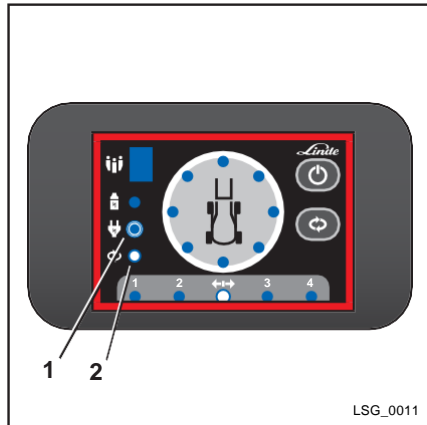
**Checking pairing with a Distance Beeper**

**NOTE**

*If the driver is carrying a Distance Beeper, it must be paired with the Truck Unit. This prevents a signaling message from being triggered.*

Pairing is carried out automatically:

- LED (2) lights up green:  
Distance Beeper is paired and within range of the Truck Unit.
- LED (2) lights up red:  
Distance Beeper is paired but not within range of the Truck Unit.

## Checking the operational readiness sensors

### WARNING

The sensors must be ready for operation before work operations begin.

➤ Check LEDs 1 to 4 (1). LED 4 is optional.

➤ Switch on the industrial truck.

The Truck Unit switches on.

- LEDs 1 to 4 light up green for ten seconds.
- If the sensors are ready for operation, the LEDs go out after ten seconds.

If a sensor is faulty, the corresponding LED lights up red.

### WARNING

Faulty sensors cannot merely be replaced.

➤ Register the sensors with the Truck Unit system via the configurator.

➤ Contact your service partner for advice.

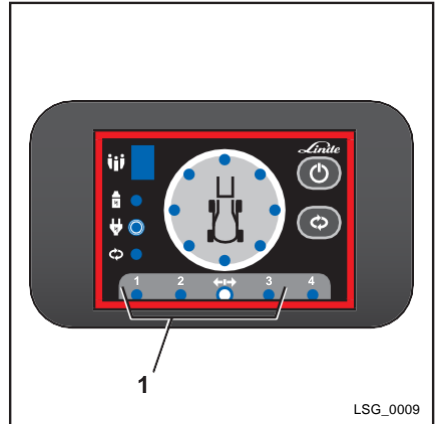

Pre-shift checks

Performing a functional test

**DANGER**

Note that the signals given by the system are additional information for the driver. However, the driver is still responsible to drive safely and keep the control over the fork lift truck at any time!

- Always perform a functional test before starting work.

**NOTE**

The signaling zones are pre-configured by the manufacturer. They must be adapted to suit the local conditions during initial installation. To do this, contact your authorized service partner.

Functional test of the Truck Unit

During the functional test, the set signaling zones are checked. **Two (2) people are required for the testing.**

- Switch on the industrial truck.

The Truck Unit switches on.

- Switch on the Distance Beeper and attach the unit to your clothing.
- Walk around the industrial truck in a spiral shape with the Distance Beeper. During this time, the driver checks the Truck Unit.

During the test run, no fault messages or irregularities must appear on the Truck Unit.

- If necessary, have the signaling zones set up again by the service partner.

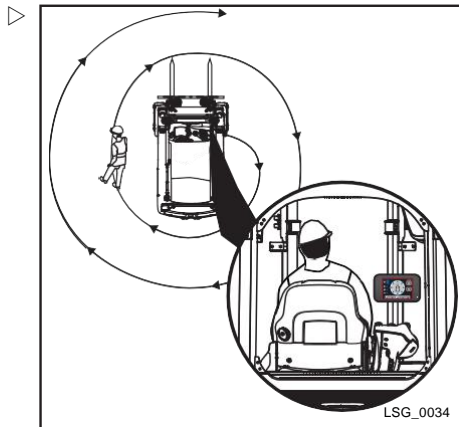

### Functional test of the Static Unit

**i** NOTE

The functional test must be completed regardless of the industrial truck component configuration. When using the Truck Unit Small, perform the following steps as well.

The functional test checks the signaling zones that have been set and any responses that have been set on the industrial truck.

- Switch on the industrial truck.

The Truck Unit switches on.

- Check the operational readiness of the Static Unit.

The "operating status" LED must flash green.

- Drive the industrial truck to the signaling zone. During this process, the driver monitors the Truck Unit and any responses that have been set on the industrial truck. A second person monitors the Static Unit.

Fault messages and irregularities on the Truck Unit or the Static Unit during the test are not permitted.

- If necessary, have the signaling zones and the truck settings set up again by the service partner.

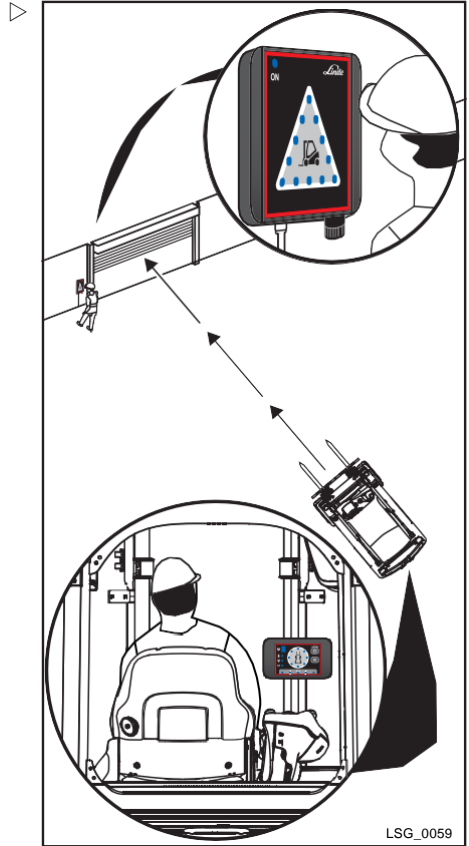

Pre-shift checks

**Functional test of the Zone Marker/  
PoE Anchor**

 **NOTE**

*The functional test must be completed regardless of the industrial truck component configuration. When using the Truck Unit Small, perform the following steps as well.*

The functional test checks the signaling zones that have been set and any responses that have been set on the industrial truck.

- Switch on the industrial truck.

The Truck Unit switches on.

- Check the operational readiness of the Zone Marker.

The "operating status" LED must flash green.

- Drive the industrial truck to the signaling zone. During this process, the driver monitors the Truck Unit and any responses that have been set on the industrial truck. A second person monitors the Zone Marker.

Fault messages and irregularities on the Truck Unit or the Zone Marker during the test are not permitted.

- If necessary, have the signaling zones and the truck settings set up again by the service partner.

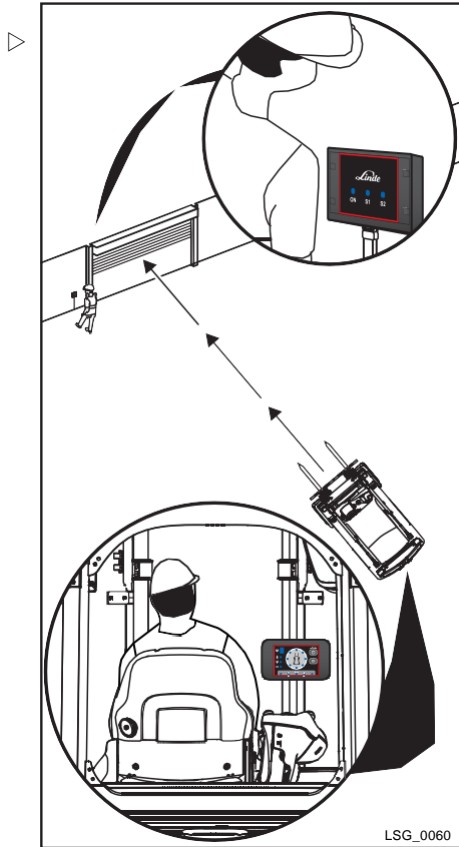

## Operation

### Switching on the Truck Unit 1/2

- Switch on the industrial truck.

The Truck Unit starts as follows and runs a self-test:

- The numerical display lights up
- Depending on the number of sensors, the numerical display counts down from 3 or 4 to 0. The signaling zone lights up each time
- The switching output LED lights up red and the power supply LED flashes green
- The LEDs for the sensors light up red and the switching output LED lights up green
- The LEDs for the sensors light up green for ten seconds and then go out. A signal tone is emitted

After approximately 15 seconds, the Truck Unit is ready for operation.

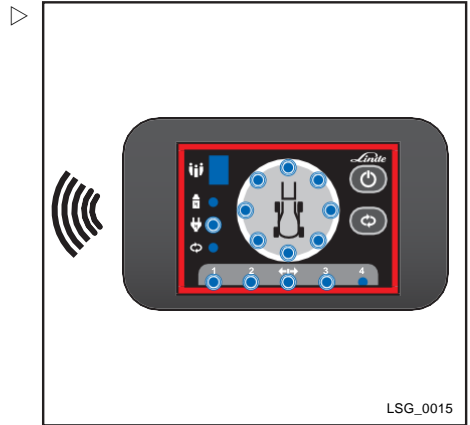

### Switching on the Distance Beeper

- Push the push button (1) and hold it until the Distance Beeper starts. If the button is deactivated by configuration, put the Distance Beeper on the inductive charger and remove it for activating the device.

The Distance Beeper starts as follows:

- The Distance Beeper emits a signal tone, the LEDs in the signaling zone light up and the device vibrates.

The starting procedure is completed.



#### NOTE

*If the push button (1) is released too early, the starting procedure must be repeated. This button safety device prevents the unit being switched on and off accidentally in normal operation.*

- To switch off the unit, push the push button (1) and hold it until the Distance Beeper shuts down.



## Operation

The LEDs light up briefly. A signal tone sounds. The Distance Beeper vibrates briefly and shuts down.

## Pairing the Distance Beeper

### WARNING

If a Distance Beeper is within the pairing zone of the industrial truck, the unit is paired automatically with the Truck Unit and muted.

As long as it is in the paired zone, it does not interact with any Truck Unit and, hence, does not give a signal.

### DANGER

The Linde Guardian System offers a muting function for the forklift truck driver's pedestrian tag. Note that a different person than the driver can mute his pedestrian tag. Especially, if vehicle muting zone is too large

A risk assessment must be performed by the EHS manager to analyze if there are circumstances that may harm people during the usage of the system (cf. section Safety Information).



### NOTE

*The pairing function has to be activated by a service partner.*

- Move the Distance Beeper into the pairing zone of the Truck Unit.

The LED display (1) on the Truck Unit lights up green. The Truck Unit does not issue a signal message.

- To deactivate the pairing function, move out of the signaling zones of the industrial truck.



### NOTE

*Only one Distance Beeper can be paired with the Truck Unit at any one time. Once paired the Distance Beeper does not interact with any Truck Unit.*

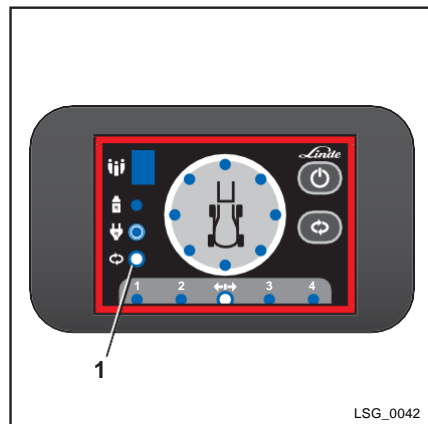

LSG\_0042

## Displays during operation

### WARNING

To avoid risk of injury, the components of the Linde Guardian System does not have to be operated when in working mode. The signals and the operating status that are displayed when the Truck Unit makes contact with other components of the system are described below.

- Observe the displays with signals and operating states.

## Distance Beeper in the extended area

### WARNING

If an industrial truck stops abruptly, this can result in an accident that may cause serious injury and material damage!

- You must not reduce speed to 0 mp/h.
- People with a Distance Beeper enter the extended area of the industrial truck with the Truck Unit.

The LEDs for the signaling zones on the Truck Unit flash red. A signal tone is emitted. Depending on the programming and equipment, the industrial truck reduces the driving speed and the LED switching output lights up red. In addition to the number of people in the extended area, the Truck Unit also indicates the direction from which a person is approaching.

The following operating statuses are possible:

- One person in the extended area:  
Three LEDs flash and indicate the direction from which the person is approaching.
- More than one person in the extended area:  
The entire circle flashes red.

All the LEDs for the signaling zone flash on the Distance Beeper. A signal tone is output and the device vibrates.

After a configurable timeout, the tone and vibration alarm are deactivated. Only a visual signal remains. There is a software option to set a permanent signal.

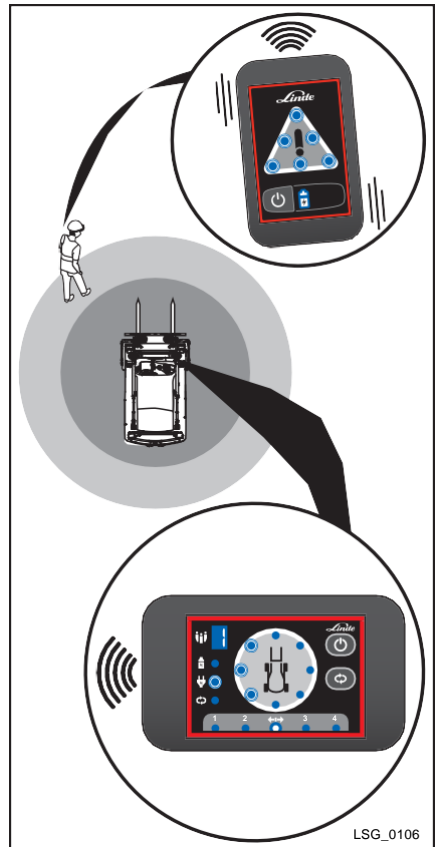



**Operation**
**Distance Beeper in the immediate vicinity** ▷

- People with a Distance Beeper enter the immediate vicinity of the industrial truck with the Truck Unit.

All the LEDs for the signaling zones on the Truck Unit flash red. A signal tone is emitted. In addition, the number of people in the immediate vicinity is displayed. Depending on the programming and equipment, the industrial truck reduces the driving speed and the LED switching output lights up red.

All the LEDs for the signaling zone flash on the Distance Beeper. A signal tone is output and the device vibrates.

After a configurable timeout, the tone and vibration alarm are deactivated. Only a visual signal remains. There is a software option to set a permanent signal.

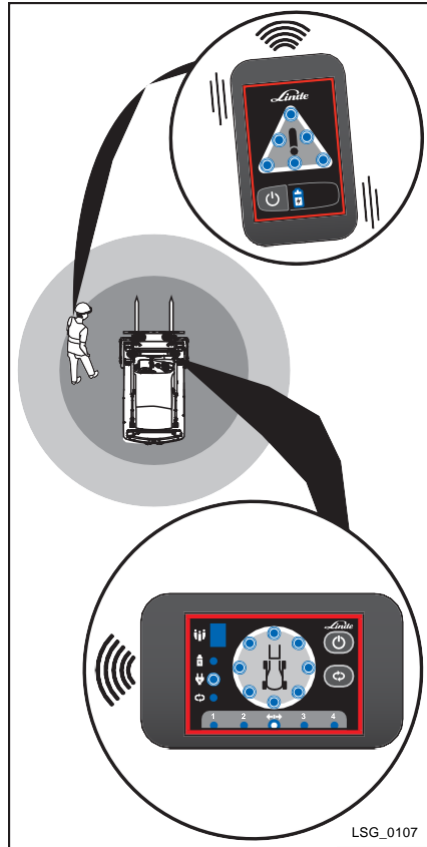

LSG\_0107

### Static Unit

#### WARNING

If an industrial truck stops abruptly, this can result in an accident that may cause serious injury and material damage!

- You must not reduce speed to 0 mp/h.
- Adjust the speed before entering the signaling zone.
- **ALWAYS** keep the surrounding area in view.

#### Industrial trucks with Truck Unit

- The industrial truck enters the signaling zone for the Static Unit.

The switching output LED lights up red on the Truck Unit.

All the LEDs for the signaling zone flash on the Static Unit. An optional signal tone is also possible. Depending on the programming and the equipment, responses on the industrial truck and additional signal lights can be activated.

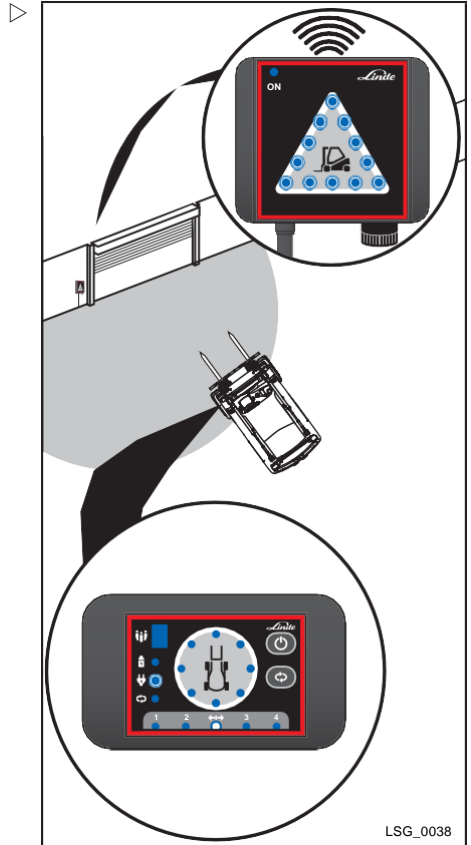

LSG\_0038

## Operation

### Industrial trucks with Truck Unit Small

- The industrial truck enters the signaling zone for the Static Unit.

The LEDs for the signaling zones light up red on the Truck Unit Small.

All the LEDs for the signaling zone flash on the Static Unit. An optional signal tone is also possible. Depending on the programming and the equipment, responses on the industrial truck and additional signal lights can be activated.

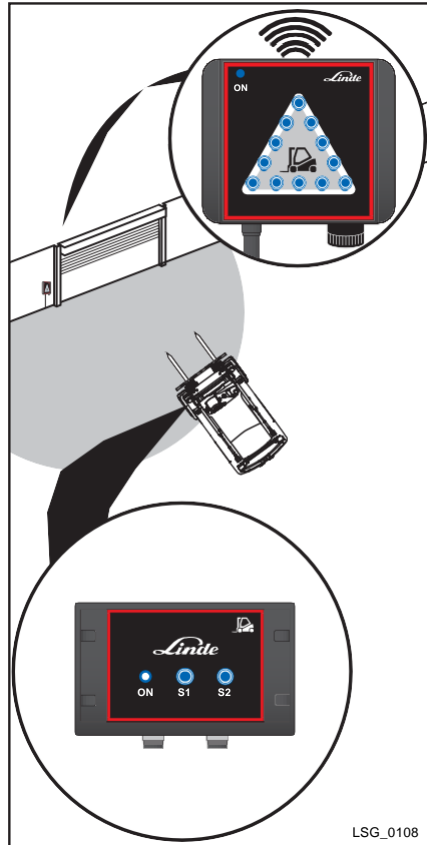

LSG\_0108

### Zone Marker

#### WARNING

If an industrial truck stops abruptly, this can result in an accident that may cause serious injury and material damage!

- You must not reduce speed to 0 mp/h.
- Adjust the speed before entering the signaling zone.
- **ALWAYS** keep the surrounding area in view.

#### Industrial trucks with Truck Unit

- The industrial truck enters the signaling zone of the Zone Marker.

The switching output LED lights up red on the Truck Unit.

The LEDs for the signaling zones light up red on the Zone Marker. An optional signal tone is also possible. Depending on the programming and the equipment, responses on the industrial truck and additional signaling lights can be activated.

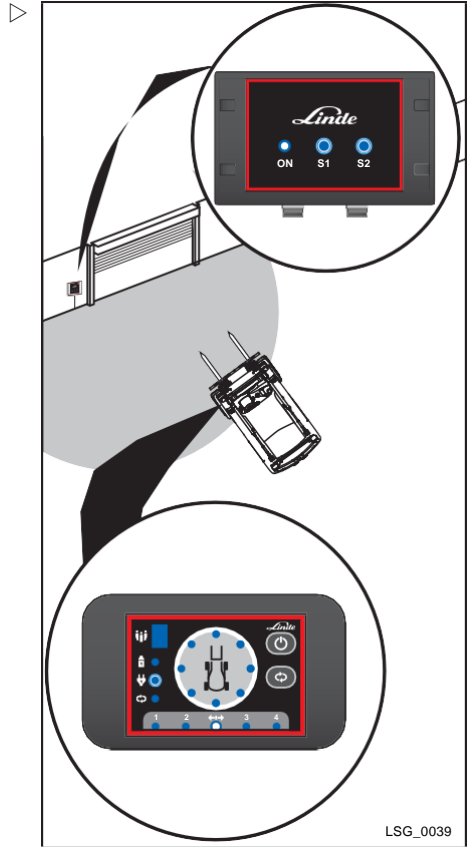

LSG\_0039

## Operation

### Industrial trucks with Truck Unit Small

- The industrial truck enters the signaling zone of the Zone Marker.

The LEDs for the signaling zones light up red on the Truck Unit Small.

The LEDs for the signaling zones light up red on the Zone Marker. An optional signal tone is also possible. Depending on the programming and the equipment, responses on the industrial truck and additional signaling lights can be activated.

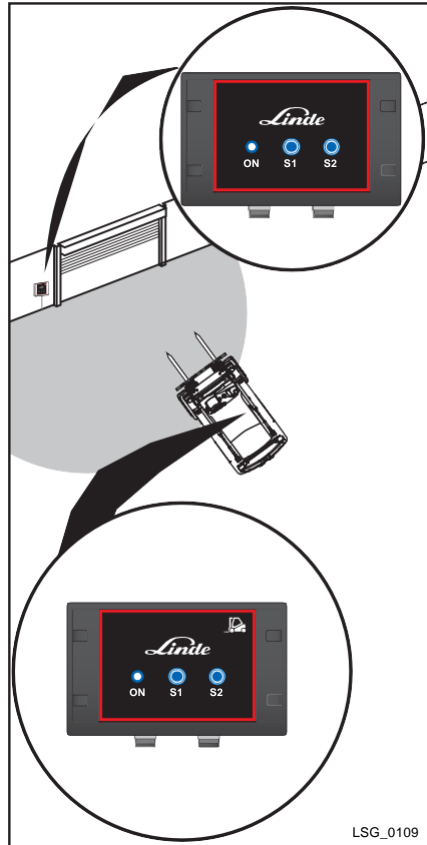

### Signaling between industrial trucks

The signaling between industrial trucks works when the industrial trucks are equipped with Truck Units and a fifth Sensor Truck Unit. Alternatively, the signaling works if the industrial trucks are equipped with a Truck Unit Small 2 or a Truck Unit Small.

#### Industrial trucks with Truck Unit

The display is the same as for contact with a Distance Beeper.

- The industrial truck with Truck Unit enters the extended area.

The LEDs for the signaling zones flash on the Truck Unit and indicate the direction from which the industrial truck is approaching.

- The industrial truck with Truck Unit enters the immediate vicinity.

All the LEDs for the signaling zones flash on the Truck Unit.

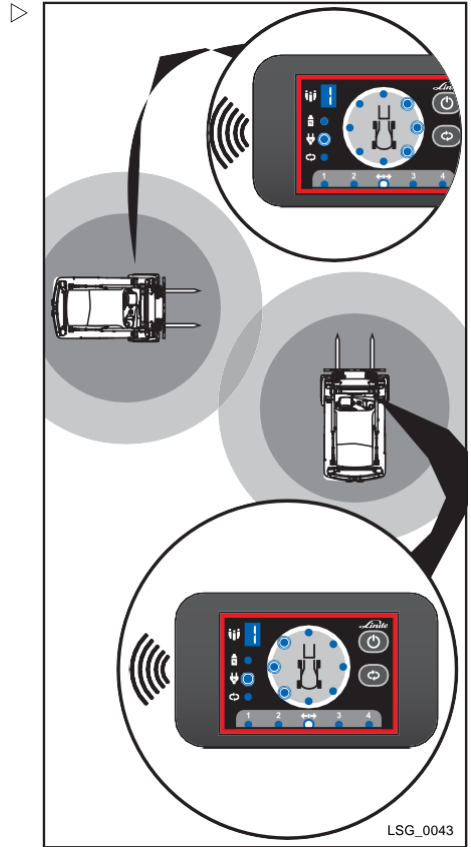

## Operation

### Industrial trucks with Truck Unit Small

- The industrial truck with a Truck Unit Small reaches the extended area.

The LEDs for the signaling zones flash orange on the Truck Unit Small.

- The industrial truck with the Truck Unit Small reaches the immediate vicinity.

The LEDs for the signaling zones flash red on the Truck Unit Small.

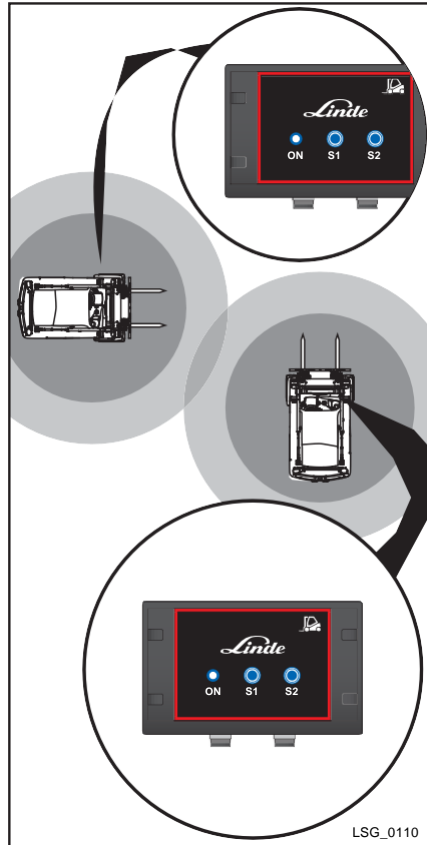

---

# Maintenance and disposal





### Maintenance

## Maintenance

#### CAUTION

Risk of surface damage from using incorrect cleaning materials.

- Do not use aggressive cleaning materials.
- Do not use cleaning materials containing abrasive particles

Regularly cleaning the components of the Linde Guardian System increases the service life of the system. After daily use, perform the following steps:

- Check the Truck Units, the sensors and the signaling units for contamination.

- Remove coarse dirt with a soft brush.
- Remove fine dust and film with a damp cloth.

#### CAUTION

Lithium-ion battery destroyed as a result of deep discharge.

Do not store the Distance Beeper for more than one year.

Charge the Distance Beeper after one year.

## Disposal



#### ENVIRONMENT NOTE

*Waste electronic equipment and batteries are raw materials and are not considered household waste. Disposal with household waste is not permitted.*

- *At the end of their service life, waste equipment and batteries must be disposed of in accordance with the national regulations.*



#### ENVIRONMENT NOTE

*We recommend working with a waste management company for disposal requirements.*

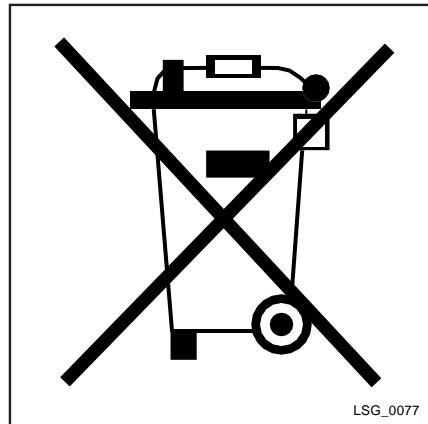

## California Proposition 65

#### WARNING

Using this product can expose you to chemicals including arsenic (inorganic), cadmium, lead, nickel, and/or mercury, which are known to the State of California to cause cancer and birth defects or other reproductive harm.

For more information go to <https://www.p65warnings.ca.gov/>.

# 6

---

## Technical data

## 6 Technical data

### Truck Unit

Performance data	Unit	Value
Operating voltage	VDC	12 / 24
Max. power consumption	W	Max. 6.5
Range	M	Max. 25
	ft	Max. 82
Ultrawide band Channel <b>(USA: Channel No. 1, 2, 5 available Canada: Channel No. 5 only)</b>	MHz	No. 1 (CF = 3542) No. 2 (CF = 4059) No. 5 (CF = 6489.6)
Frequency (Occupied Bandwidth)	MHz	No. 1: 3218 to 3816 No. 2: 3692 to 4354 No. 5: 6143.2 to 6820.8
Transmission power	dBm/MHz	No. 1: Max. -43.1 No. 2: Max. -42.4 No. 5: Max. -42.76
Operating temperature	°C	-20 up to +45
	°F	-4 up to +113
Air humidity	%	10-85
Dimensions	mm	76 x 120 x 24
	in	3 x 4.72 x 0.94
Weight	g	193
	Oz	6.8

## Truck Unit 2

Performance data	Unit	Value
Operating voltage	VDC	12 / 24
Max. power consumption	W	Max. 6.5
Range	M	Max. 25
	ft	Max. 82
Ultrawide band Channel <b>(USA: Channel No. 1, 2, 5 available Canada: Channel No. 5 only)</b>	MHz	No. 1: (CF = 3494) No. 2: (CF = 3994) No. 5 (CF = 6490)
Frequency (Occupied Bandwidth)	MHz	No. 1: 3190 to 3822 No. 2: 3719 to 4357 No. 5: 6082 to 6845
Transmission power	dBm/MHz	No. 1: Max. -42.6 No. 2: Max. -43.2 No. 5: Max. -42.9
Operating temperature	°C	-40 up to +85
	°F	-40 up to +185
Air humidity	%	10-85
Dimensions	mm	76 x 131 x 70
	in	3 x 5.16 x 2.75
Weight	g	200
	Oz	7.05

## 6 Technical data

### Distance Beeper

Performance data	Unit	Value
Operating voltage	VDC	3.3
Max. power consumption	W	Max. 2.5
Rechargeable battery capacity	mAh	1000
Range	M	Max. 25
	ft	Max. 82
Ultrawide band Channel <b>(USA: Channel No. 1, 2, 5 available Canada: Channel No. 5 only)</b>	MHz	No. 1: (CF = 3541) No. 2: (CF = 4059) No. 5: (CF = 6489.5)
Frequency (Occupied Bandwidth)	MHz	No. 1: 3166 to 3850 No. 2: 3614 to 4400 No. 5: 6202.1 to 6800.8
Transmission power	dBm/MHz	No. 1: max. -48.1 No. 2: max. -43.4 No. 5: max. -42.96
Operating temperature (lower value - discharging only)	°C	-20 up to +45
	°F	-4 up to +113
Air humidity	%	10-85
Dimensions	mm	51 x 82 x 14
	in	2 x 3.22 x 0.55
Weight	g	77
	Oz	2.72

## Sensor Truck Unit

Performance data	Unit	Value
Operating voltage	VDC	5
Max. power consumption	W	1
Range	M	Max. 25
	ft	Max. 82
Ultrawide band Channel <b>(USA: Channel No. 1, 2, 5 available Canada: Channel No. 5 only)</b>	MHz	No. 1 (CF = 3494) No. 2 (CF = 4136) No. 5 (CF = 6489)
Frequency	MHz	No. 1: 3156 to 3847 No. 2: 3663 to 4400 No. 5: 6149.2 to 6812.8
Transmission power	dBm/MHz	No. 1 max. - 46.2 No. 2 max. - 43.7 No. 5 max. - 41.51
Operating temperature	°C	-20 up to +45
	°F	-4 up to +113
Air humidity	%	10-85
Dimensions	mm	45 x 85 x 22
	in	1.77 x 3.34 x 0.86
Weight	g	81
	Oz	2.86

## 6 Technical data

### Truck Unit Small

Performance data	Unit	Value
Operating voltage	VDC	12 / 24
Max. power consumption	W	Max. 3.5
Range	M	Max. 25
	ft	Max. 82
Ultrawide band Channel <b>(USA: Channel No. 1, 2, 5 available Canada: Channel No. 5 only)</b>	MHz	No. 1 (CF = 3542) No. 2 (CF = 4149) No. 5 (CF = 6489.6)
Frequency (Occupied Bandwidth)	MHz	No.1: 3166 to 3816 No.2: 3663 to 4381 No.5: 6138.2 to 6805.8
Transmission power	dBm/MHz	No. 1: Max. - 46.3 No. 2: Max. - 43.6 No. 5: Max. - 42.25
Operating temperature	°C	-20 up to +45
	°F	-4 up to +113
Air humidity	%	10-85
Dimensions w/o accessories (LxWxH)	mm	100 x 60 x 40
	in	3.93 x 2.36 x 1.57
Weight	g	149
	Oz	5.26



## Truck Unit Small 2

<b>Performance data</b>	<b>Unit</b>	<b>Value</b>
Operating voltage	VDC	12 / 24
Max. power consumption	W	Max. 3.5
Range	M	Max. 25
	ft	Max. 82
Ultrawide band Channel <b>(USA: Channel No. 1, 2, 5 available Canada: Channel No. 5 only)</b>	MHz	No. 1 (CF = 3602) No. 2 (CF = 4137) No. 5 (CF = 6490)
Frequency (Occupied Bandwidth)	MHz	No. 1: 3187 to 3839 No. 2: 3696 to 4361 No. 5: 6126 to 6826
Transmission power	dBm/MHz	No. 1: Max. - 45 No. 2: Max. - 42.5 No. 5: Max. - 43.7
Operating temperature	°C	-40 up to +85
	°F	-40 up to +185
Air humidity	%	10-85
Dimensions w/o accessories (LxWxH)	mm	123 x 86 x 35
	in	4.84 x 3.39 x 1.38
Weight	g	100
	Oz	3.5

## 6 Technical data

### Static Unit

Performance data	Unit	Value
Operating voltage	VAC	90 - 264
Max. power consumption	W	Max. 6
Range	M	Max. 25
	ft	Max. 82
Ultrawide band Channel <b>(USA: Channel No. 1, 2, 5 available Canada: Channel No. 5 only)</b>	MHz	No. 1 (CF = 3494) No. 2 (CF = 4163) No. 5 (CF = 6489.6)
Frequency (Occupied Bandwidth)	MHz	No. 1: 3150 to 3770 No. 2: 3695 to 4328 No. 5: 6164.2 to 6853.8
Transmission power	dBm/MHz	No. 1: Max. - 43.1 No. 2: Max. - 43.1 No. 5: Max. - 43.23
Operating temperature	°C	-20 up to +45
	°F	-4 up to +113
Air humidity	%	10-85
Dimensions	mm	150 x 180 x 60
	in	5.9 x 7.09 x 2.36
Weight	g	935
	Oz	32.98

## Zone Marker

Performance data	Unit	Value
Operating voltage	VDC	12 / 24
Max. power consumption	W	Max. 3.5
Range	M	Max. 25
	ft	Max. 82
Ultrawide band Channel <b>(USA: Channel No. 1, 2, 5 available Canada: Channel No. 5 only)</b>	MHz	No. 1 (CF = 3364) No. 2 (CF = 4099) No. 5 (CF = 6489.5)
Frequency (Occupied Bandwidth)	MHz	No. 1: 3179 to 3790 No. 2: 3684 to 4349 No. 5: 6158.2 to 6804.8
Transmission power	dBm/MHz	No 1: max. -43.6 No 2: max. -43.6 No 5: max. -41.90
Operating temperature	°C	-20 up to +45
	°F	-4 up to +113
Air humidity	%	10-85
Dimensions w/o accessories (LxWxH)	mm	100 x 60 x 40
	in	3.93 x 2.36 x 1.57
Weight	g	149
	Oz	5.26

## PoE Anchor

Performance data	Unit	Value
Operating voltage	VDC	36-57
Max. power consumption	W	Max. 5
Range	M	Max. 25
	ft	Max. 82
Ultrawide band Channel <b>(USA: Channel No. 1, 2, 5 available Canada: Channel No. 5 only)</b>	MHz	No. 1 (CF = 3457) No. 2 (CF = 4138) No. 5 (CF = 6489)
Frequency (Occupied Bandwidth)	MHz	No. 1: 3191 to 3785 No. 2: 3732 to 4338 No. 5: 6186 to 6788
Transmission power	dBm/MHz	No 1: max. -45.9 No 2: max. -42.6 No 5: max. -42.7
Operating temperature	°C	-40 up to +85
	°F	-40 up to +185
Air humidity	%	10-85
Dimensions w/o accessories (LxWxH)	mm	100 x 60 x 40
	in	3.93 x 2.36 x 1.57
Weight	g	159
	Oz	5.6

## 6 Technical data

### Programmer

Performance data	Unit	Value
Operating voltage	VAC	5
Max. power consumption	W	1
Range	M	Max. 25
	ft	Max. 82
Ultrawide band Channel <b>(USA: Channel No. 1, 2, 5 available Canada: Channel No. 5 only)</b>	MHz	No. 1: (CF = 3494) No. 2: (CF = 4136) No. 5: (CF = 6489.6)
Frequency (Occupied Bandwidth)	MHz	No.1: 3172 to 3847 No.2: 3671 to 4392 No.5: 6166.2 to 6804.8
Transmission power	dBm/MHz	No. 1: max. -46.98 No. 2: max. -43.56 No. 5: max. -41.95
Operating temperature	°C	-20 up to +45
	°F	-4 up to +113
Air humidity	%	10-85
Dimensions	mm	85 x 45 x 22
	in	3.34 x 1.77 x 0.86
Weight	g	81
	Oz	2.86