

FCC Test Report (U-NII-4 Band)

Report No.: RFBEMT-WTW-P21090660-5

FCC ID: 2AYRA-08321

Test Model: MR2000

Variant Model: MR20MS, MR20EC, ME20WH (Refer to item 3.1 for more details)

Received Date: Sep. 30, 2021

Test Date: Oct. 09 ~ Nov. 21, 2021

Issued Date: Jan. 18, 2022

Applicant: Linksys USA, Inc.

Address: 121 Theory, Irvine, CA 92617, USA

Issued By: Bureau Veritas Consumer Products Services (H.K.) Ltd., Taoyuan Branch
Lin Kou Laboratories

Lab Address: No. 47-2, 14th Ling, Chia Pau Vil., Lin Kou Dist., New Taipei City, Taiwan

Test Location (1): No. 19, Hwa Ya 2nd Rd., Wen Hwa Vil., Kwei Shan Dist., Taoyuan City
33383, Taiwan

Test Location (2): No. 70, Wenming Rd., Guishan Dist., Taoyuan City 333, Taiwan

**FCC Registration /
Designation Number (1):** 788550 / TW0003

**FCC Registration /
Designation Number (2):** 281270 / TW0032



This report is for your exclusive use. Any copying or replication of this report to or for any other person or entity, or use of our name or trademark, is permitted only with our prior written permission. This report sets forth our findings solely with respect to the test samples identified herein. The results set forth in this report are not indicative or representative of the quality or characteristics of the lot from which a test sample was taken or any similar or identical product unless specifically and expressly noted. Our report includes all of the tests requested by you and the results thereof based upon the information that you provided to us. You have 60 days from date of issuance of this report to notify us of any material error or omission caused by our negligence, provided, however, that such notice shall be in writing and shall specifically address the issue you wish to raise. A failure to raise such issue within the prescribed time shall constitute your unqualified acceptance of the completeness of this report, the tests conducted and the correctness of the report contents. Unless specifically mentioned, the uncertainty of measurement has been explicitly taken into account to declare the compliance or non-compliance to the specification.

Table of Contents

Release Control Record	4
1 Certificate of Conformity	5
2 Summary of Test Results	6
2.1 Measurement Uncertainty.....	6
2.2 Modification Record.....	6
3 General Information	7
3.1 General Description of EUT.....	7
3.2 Description of Test Modes.....	9
3.2.1 Test Mode Applicability and Tested Channel Detail.....	10
3.3 Duty Cycle of Test Signal.....	12
3.4 Description of Support Units.....	13
3.4.1 Configuration of System under Test.....	13
3.5 General Description of Applied Standard.....	14
4 Test Types and Results	15
4.1 Radiated Emission and Bandedge Measurement.....	15
4.1.1 Limits of Radiated Emission and Bandedge Measurement.....	15
4.1.2 Test Instruments.....	16
4.1.3 Test Procedure.....	17
4.1.4 Test Setup.....	18
4.1.5 EUT Operating Condition.....	19
4.1.6 Test Results.....	20
4.2 Conducted Emission Measurement.....	34
4.2.1 Limits of Conducted Emission Measurement.....	34
4.2.2 Test Instruments.....	34
4.2.3 Test Procedure.....	35
4.2.4 Test Setup.....	35
4.2.5 EUT Operating Condition.....	35
4.2.6 Test Results.....	36
4.3 Transmit Power Measurement.....	40
4.3.1 Limits of Transmit Power Measurement.....	40
4.3.2 Test Setup.....	40
4.3.3 Test Instruments.....	40
4.3.4 Test Procedure.....	40
4.3.5 EUT Operating Condition.....	40
4.3.6 Test Result.....	41
4.4 6dB Bandwidth Measurement.....	43
4.4.1 Limits of Emission Bandwidth Measurement.....	43
4.4.2 Test Setup.....	43
4.4.3 Test Instruments.....	43
4.4.4 Test Procedure.....	43
4.4.5 Test Results.....	44
4.5 Peak Power Spectral Density Measurement.....	46
4.5.1 Limits of Peak Power Spectral Density Measurement.....	46
4.5.2 Test Setup.....	46
4.5.3 Test Instruments.....	46
4.5.4 Test Procedure.....	46
4.5.5 EUT Operating Condition.....	46
4.5.6 Test Results.....	47
4.6 Frequency Stability Measurement.....	50
4.6.1 Limits of Frequency Stability Measurement.....	50
4.6.2 Test Setup.....	50
4.6.3 Test Instruments.....	50
4.6.4 Test Procedure.....	50

4.6.5 EUT Operating Condition	50
4.6.6 Test Results	51
4.7 Operational Restrictions for U-NII 4 Devices	52
4.7.1 Limits of Operational Restrictions for U-NII 4 Devices	52
4.7.2 Test Setup	52
4.7.3 Test Instruments	52
4.7.4 Test Procedure	52
4.7.5 Test Results	52
5 Pictures of Test Arrangements	53
Annex A – Band Edge Measurement	54
Appendix – Information of the Testing Laboratories	58

Release Control Record

Issue No.	Description	Date Issued
RFBEMT-WTW-P21090660-5	Original release	Jan. 18, 2022

1 Certificate of Conformity

Product: AX3000 DUAL-BAND WIFI 6 ROUTER
Brand: LINKSYS
Test Model: MR2000
Variant Model: MR20MS, MR20EC, ME20WH (Refer to item 3.1 for more details)
Sample Status: Engineering sample
Applicant: Linksys USA, Inc.
Test Date: Oct. 09 ~ Nov. 21, 2021
Standard: 47 CFR FCC Part 15, Subpart E (Section 15.407)
ANSI C63.10: 2013

The above equipment has been tested by **Bureau Veritas Consumer Products Services (H.K.) Ltd., Taoyuan Branch**, and found compliance with the requirement of the above standards. The test record, data evaluation & Equipment Under Test (EUT) configurations represented herein are true and accurate accounts of the measurements of the sample's EMC characteristics under the conditions specified in this report.

Prepared by : Pettie Chen , **Date:** Jan. 18, 2022
Pettie Chen / Senior Specialist

Approved by : Jeremy Lin , **Date:** Jan. 18, 2022
Jeremy Lin / Project Engineer

2 Summary of Test Results

47 CFR FCC Part 15, Subpart E (Section 15.407)			
FCC Clause	Test Item	Result	Remarks
15.407(b)(9)	AC Power Conducted Emissions	Pass	Meet the requirement of limit. Minimum passing margin is -12.72dB at 0.44527MHz.
15.407(b)(5)(9)	Radiated Emissions	Pass	Meet the requirement of limit. Minimum passing margin is -1.0dB at 5925.00MHz.
15.407(a)(3)	Max Average Transmit Power	Pass	Meet the requirement of limit.
15.407(a)(3)	Peak Power Spectral Density	Pass	Meet the requirement of limit.
15.407(e)	6dB Bandwidth Measurement	Pass	Meet the requirement of limit.
15.407(g)	Frequency Stability	Pass	Meet the requirement of limit.
15.403	Operational restrictions U-NII 4 devices	Pass	Declaration by applicant
15.203 or 15.403	Antenna Requirement	Pass	Antenna connector are ipex(MHF) not a standard connector.

Note:

Determining compliance based on the results of the compliance measurement, not taking into account measurement instrumentation uncertainty.

2.1 Measurement Uncertainty

Where relevant, the following measurement uncertainty levels have been estimated for tests performed on the EUT as specified in CISPR 16-4-2:

Measurement	Frequency	Expanded Uncertainty (k=2) (±)
Conducted Emissions at mains ports	150kHz ~ 30MHz	2.79 dB
Radiated Emissions up to 1 GHz	9kHz ~ 30MHz	3.04 dB
	30MHz ~ 200MHz	3.63 dB
	200MHz ~ 1000MHz	3.64 dB
Radiated Emissions above 1 GHz	1GHz ~ 18GHz	2.29 dB
	18GHz ~ 40GHz	2.29 dB

2.2 Modification Record

There were no modifications required for compliance.

3 General Information

3.1 General Description of EUT

Product	AX3000 DUAL-BAND WIFI 6 ROUTER
Brand	LINKSYS
Test Model	MR2000
Variant Model	MR20MS, MR20EC, ME20WH
Model Difference	for Marketing purpose
Status of EUT	Engineering sample
Power Supply Rating	12Vdc from Adapter
Modulation Type	256QAM, 64QAM, 16QAM, QPSK, BPSK for OFDM 1024QAM, 256QAM, 64QAM, 16QAM, QPSK, BPSK for OFDMA
Modulation Technology	OFDM, OFDMA
Transfer Rate	802.11a: up to 54 Mbps 802.11n: up to 300 Mbps 802.11ac: up to 1733.3Mbps 802.11ax: up to 2401.9Mbps
Operating Frequency	5.845 ~ 5.885 GHz
Number of Channel	802.11a, 802.11n (HT20), 802.11ac (VHT20), 802.11ax (HE20): 3 802.11n (HT40), 802.11ac (VHT40), 802.11ax (HE40): 2 802.11ac (VHT80), 802.11ax (HE80): 1 802.11ac (VHT160), 802.11ax (HE160): 1
EIRP	CDD Mode: 33.36dBm (2167.704mW) Beamforming Mode: 35.93 dBm (3917.419 mW)
Antenna Type	Refer to Note
Antenna Connector	Refer to Note
Accessory Device	Refer to Note
Data Cable Supplied	Refer to Note

Note:

1. The EUT incorporates a MIMO function. Physically, the EUT provides two completed transmitters and two receivers.

Modulation Mode	Beamforming Mode	TX Function
802.11a	Not Support	2TX
802.11n (HT20)	Support	2TX
802.11n (HT40)	Support	2TX
802.11ac (VHT20)	Support	2TX
802.11ac (VHT40)	Support	2TX
802.11ac (VHT80)	Support	2TX
802.11ac (VHT160)	Support	2TX
802.11ax (HE20)	Support	2TX
802.11ax (HE40)	Support	2TX
802.11ax (HE80)	Support	2TX
802.11ax (HE160)	Support	2TX

* The bandwidth and modulation are similar for HT20/HT40 on 802.11n mode and VHT20/VHT40 on 802.11ac mode and HE20/HE40/HE80 on 802.11ax mode. Therefore the investigated worst case is the representative mode in test report. (Final test mode refer section 3.2.1)

* For 802.11n and 802.11ac/ax, CDD mode and Beamforming mode are presented in power output test item. For other test items, CDD mode is the worst case for final tests after pretesting. All models are listed as below.

2. The antenna information is listed as below.

Antenna Type	Dipole	
Connector Type	ipex(MHF)	
Frequency	Antenna Gain (dBi)	
	Chain 0	Chain 1
2400~2483.5MHz	3.70	4.09
5150~5250MHz	3.65	3.46
5250~5350MHz	3.57	3.54
5470~5725MHz	3.81	3.75
5725~5850MHz	3.81	3.75
5850~5925MHz	3.71	3.48

*The above Antenna information is declared by manufacturer and for more detailed features description, please refer to the manufacturer's specifications, the laboratory shall not be held responsible.

3. The EUT uses following adapters.

Adapter 1	
Brand	Ktec
Model	KSA-18W-120150VU
Input Power	100-240Vac~50/60Hz, 0.5A
Output Power	12Vdc, 1.5A
Power line	1.5m non-shielded cable without core

Adapter 2	
Brand	Moso
Model	MSA-C1500IC12.0-18P-US
Input Power	100-240Vac~50/60Hz, 0.7A max
Output Power	12Vdc, 1.5A
Power line	1.5m non-shielded cable without core

Adapter 3	
Brand	Ktec
Model	KSA-18W-120150D5
Input Power	100-240Vac~50/60Hz, 0.5A
Output Power	12Vdc, 1.5A
Power line	1.5m non-shielded cable without core

Adapter 4	
Brand	Moso
Model	MSA-C1500IC12.0-18P-zz
Input Power	100-240Vac~50/60Hz, 0.7A
Output Power	12Vdc, 1.5A
Power line	1.5m non-shielded cable without core

* Adapter 1 & 3, 2 & 4 are identical to each other, except the plug type for different country, therefore only adapter 1 & 2 were for final test and presented in the test report.

4. WLAN 2.4GHz & 5.0GHz & BT technology can transmit at same time.

3.2 Description of Test Modes

U-NII-4 (5845 ~ 5885MHz)

3 channels are provided for 802.11a, 802.11n (HT20), 802.11ac (VHT20), 802.11ax (HE20):

Channel	Frequency	Channel	Frequency	Channel	Frequency
*169	5845 MHz	173	5865 MHz	177	5885 MHz

2 channels are provided for 802.11n (HT40), 802.11ac (VHT40), 802.11ax (HE40):

Channel	Frequency	Channel	Frequency
*167	5835 MHz	175	5875 MHz

1 channel is provided for 802.11ac (VHT80), 802.11ax (HE80):

Channel	Frequency
*171	5855 MHz

1 channel is provided for 802.11ac (VHT160), 802.11ax (HE160):

Channel	Frequency
*163	5815 MHz

Note: * Straddle channels.

3.2.1 Test Mode Applicability and Tested Channel Detail

EUT Configure Mode	Applicable To					Description
	RE \geq 1G	RE<1G	IBE	PLC	APCM	
A	√	√	√	√	√	Power from adapter 1
B	-	√	-	√	-	Power from adapter 2

Where **RE \geq 1G**: Radiated Emission above 1GHz **RE<1G**: Radiated Emission below 1GHz
PLC: Power Line Conducted Emission **APCM**: Antenna Port Conducted Measurement
IBE: In-Band Emission (MASK)

Note:

1. The EUT had been pre-tested on the positioned of each 3 axis. The worst case was found when positioned on **X-plane**.
2. "-": Means no effect.

Radiated Emission Measurement (Above 1GHz):

- Pre-Scan has been conducted to determine the worst-case mode from all possible combinations between available modulations, data rates and antenna ports (if EUT with antenna diversity architecture).
- Following channel(s) was (were) selected for the final test as listed below.

EUT Configure Mode	Mode	FREQ. Band (MHz)	Available Channel	Tested Channel	Modulation Technology	Modulation Type	Data Rate Parameter
A	802.11a	5845-5885	169 to 177	169, 173, 177	OFDM	BPSK	6Mb/s
A	802.11ax (HE20)	5845-5885	169 to 177	169, 173, 177	OFDMA	BPSK	MCS0
A	802.11ax (HE40)	5835-5875	167 to 175	167, 175	OFDMA	BPSK	MCS0
A	802.11ax (HE80)	5855-5855	171	171	OFDMA	BPSK	MCS0
A	802.11ax (HE160)	5815-5815	163	163	OFDMA	BPSK	MCS0

Radiated Emission Measurement (Below 1GHz):

- Pre-Scan has been conducted to determine the worst-case mode from all possible combinations between available modulations, data rates and antenna ports (if EUT with antenna diversity architecture).
- Following channel(s) was (were) selected for the final test as listed below.

EUT Configure Mode	Mode	FREQ. Band (MHz)	Available Channel	Tested Channel	Modulation Technology	Modulation Type	Data Rate Parameter
A, B	802.11ax (HE160)	5815-5815	163	163	OFDMA	BPSK	MCS0

Power Line Conducted Emission Measurement:

- Pre-Scan has been conducted to determine the worst-case mode from all possible combinations between available modulations, data rates and antenna ports (if EUT with antenna diversity architecture).
- Following channel(s) was (were) selected for the final test as listed below.

EUT Configure Mode	Mode	FREQ. Band (MHz)	Available Channel	Tested Channel	Modulation Technology	Modulation Type	Data Rate Parameter
A, B	802.11ax (HE160)	5815-5815	163	163	OFDMA	BPSK	MCS0

Bandwidth, Power Spectral Density and Frequency Stability Measurement:

- This item includes all test value of each mode, but only includes spectrum plot of worst value of each mode.
- Pre-Scan has been conducted to determine the worst-case mode from all possible combinations between available modulations, data rates and antenna ports (if EUT with antenna diversity architecture).
- Following channel(s) was (were) selected for the final test as listed below.

EUT Configure Mode	Mode	FREQ. Band (MHz)	Available Channel	Tested Channel	Modulation Technology	Modulation Type	Data Rate Parameter
A	802.11a	5845-5885	169 to 177	169, 173, 177	OFDM	BPSK	6Mb/s
A	802.11ax (HE20)	5845-5885	169 to 177	169, 173, 177	OFDMA	BPSK	MCS0
A	802.11ax (HE40)	5835-5875	167 to 175	167, 175	OFDMA	BPSK	MCS0
A	802.11ax (HE80)	5855-5855	171	171	OFDMA	BPSK	MCS0
A	802.11ax (HE160)	5815-5815	163	163	OFDMA	BPSK	MCS0

Transmit Power Measurement:

- This item includes all test value of each mode, but only includes spectrum plot of worst value of each mode.
- Pre-Scan has been conducted to determine the worst-case mode from all possible combinations between available modulations, data rates and antenna ports (if EUT with antenna diversity architecture).
- Following channel(s) was (were) selected for the final test as listed below.

EUT Configure Mode	Mode	FREQ. Band (MHz)	Available Channel	Tested Channel	Modulation Technology	Modulation Type	Data Rate Parameter
A	802.11a	5845-5885	169 to 177	169, 173, 177	OFDM	BPSK	6Mb/s
A	802.11ac (VHT20)	5845-5885	169 to 177	169, 173, 177	OFDM	BPSK	MCS0
A	802.11ac (VHT40)	5835-5875	167 to 175	167, 175	OFDM	BPSK	MCS0
A	802.11ac (VHT80)	5855-5855	171	171	OFDM	BPSK	MCS0
A	802.11ac (VHT160)	5815-5815	163	163	OFDM	BPSK	MCS0
A	802.11ax (HE20)	5845-5885	169 to 177	169, 173, 177	OFDMA	BPSK	MCS0
A	802.11ax (HE40)	5835-5875	167 to 175	167, 175	OFDMA	BPSK	MCS0
A	802.11ax (HE80)	5855-5855	171	171	OFDMA	BPSK	MCS0
A	802.11ax (HE160)	5815-5815	163	163	OFDMA	BPSK	MCS0

Test Condition:

Applicable To	Environmental Conditions	Input Power (System)	Tested By
RE \geq 1G	23 deg. C, 68% RH	120Vac, 60Hz	Edison Lee
RE<1G	21 deg. C, 65% RH	120Vac, 60Hz	Greg Lin
PLC	25 deg. C, 68% RH	120Vac, 60Hz	Raymond Lee
APCM	25 deg. C, 60% RH	120Vac, 60Hz	Alan Wu

3.3 Duty Cycle of Test Signal

Duty cycle of test signal is < 98 %, duty factor is required

802.11a: Duty cycle = $1.975\text{ms}/2.088\text{ms} = 0.946$, Duty factor = $10 * \log(1/0.946) = 0.24\text{dB}$

802.11ax (HE20): Duty cycle = $5.44\text{ms}/5.915\text{ms} = 0.92$, Duty factor = $10 * \log(1/0.92) = 0.36\text{dB}$

802.11ax (HE40): Duty cycle = $5.44\text{ms}/5.99\text{ms} = 0.908$, Duty factor = $10 * \log(1/0.908) = 0.42\text{dB}$

802.11ax (HE80): Duty cycle = $5.45\text{ms}/5.987\text{ms} = 0.91$, Duty factor = $10 * \log(1/0.91) = 0.41\text{dB}$

802.11ax (HE160): Duty cycle = $5.401\text{ms}/6.026\text{ms} = 0.896$, Duty factor = $10 * \log(1/0.896) = 0.48\text{dB}$



3.4 Description of Support Units

The EUT has been tested as an independent unit together with other necessary accessories or support units. The following support units or accessories were used to form a representative test configuration during the tests.

ID	Product	Brand	Model No.	Serial No.	FCC ID	Remarks
A.	Notebook	Lenovo	20J4 MD A003TW	PF-11H9AK	FCC DoC Approved	-
B.	Flash	Transcend	16GB	NA	NA	-
C.	Load	NA	NA	NA	NA	-

Note:

1. All power cords of the above support units are non-shielded (1.8m).
2. Item A acted as a communication partner to transfer data.

ID	Cable Descriptions	Qty.	Length (m)	Shielding (Yes/No)	Cores (Qty.)	Remarks
1.	LAN cable	1	1	N	0	RJ45, Cat5e, Accessory
2.	LAN cable	1	10	N	0	RJ45, Cat5e
3.	LAN cable	4	1.5	N	0	RJ45, Cat5e

3.4.1 Configuration of System under Test

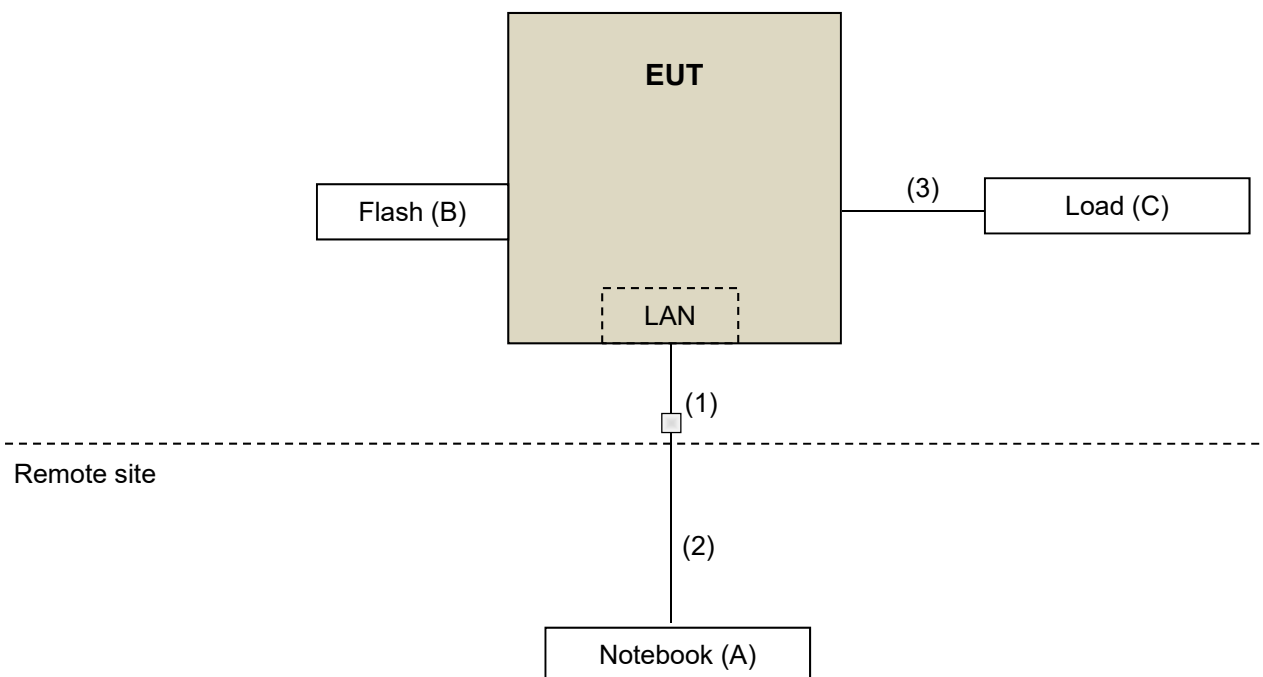

3.5 General Description of Applied Standard

The EUT is a RF Product. According to the specifications of the manufacturer, it must comply with the requirements of the following standards and references:

Test Standard:

FCC Part 15, Subpart E (15.407)

ANSI C63.10-2013

All test items have been performed and recorded as per the above standards.

References Test Guidance:

KDB 987594 D02 EMC Measurement v01r01

KDB 789033 D02 General UNII Test Procedure New Rules v02r01

KDB 662911 D01 Multiple Transmitter Output v02r01

KDB 291074 D02 EMC Measurement v01

All test items have been performed as a reference to the above KDB test guidance.

4 Test Types and Results

4.1 Radiated Emission and Bandedge Measurement

4.1.1 Limits of Radiated Emission and Bandedge Measurement

Radiated emissions which fall in the restricted bands must comply with the radiated emission limits specified as below table.

Frequencies (MHz)	Field Strength (microvolts/meter)	Measurement Distance (meters)
0.009 ~ 0.490	2400/F(kHz)	300
0.490 ~ 1.705	24000/F(kHz)	30
1.705 ~ 30.0	30	30
30 ~ 88	100	3
88 ~ 216	150	3
216 ~ 960	200	3
Above 960	500	3

NOTE:

1. The lower limit shall apply at the transition frequencies.
2. Emission level (dBuV/m) = 20 log Emission level (uV/m).
3. For frequencies above 1000MHz, the field strength limits are based on average detector, however, the peak field strength of any emission shall not exceed the maximum permitted average limits, specified above by more than 20dB under any condition of modulation.

Limits of unwanted emission out of the restricted bands

(i) For an indoor access point or subordinate device, all emissions at or above 5.895 GHz shall not exceed an e.i.r.p. of 15 dBm/MHz and shall decrease linearly to an e.i.r.p. of -7 dBm/MHz at or above 5.925 GHz.

(ii) For a client device, all emissions at or above 5.895 GHz shall not exceed an e.i.r.p. of -5 dBm/MHz and shall decrease linearly to an e.i.r.p. of -27 dBm/MHz at or above 5.925 GHz.

(iii) For a client device or indoor access point or subordinate device, all emissions below 5.725 GHz shall not exceed an e.i.r.p. of -27 dBm/MHz at 5.65 GHz increasing linearly to 10 dBm/MHz at 5.7 GHz, and from 5.7 GHz increasing linearly to a level of 15.6 dBm/MHz at 5.72 GHz, and from 5.72 GHz increasing linearly to a level of 27 dBm/MHz at 5.725 GHz.

Note:

The following formula is used to convert the equipment isotropic radiated power (eirp) to field strength:

$$E = \frac{1000000\sqrt{30P}}{3} \mu\text{V/m, where } P \text{ is the eirp (Watts).}$$

4.1.2 Test Instruments

Description & Manufacturer	Model No.	Serial No.	Cal. Date	Cal. Due
Test Receiver Rohde & Schwarz	ESR3	102783	Dec. 21, 2020	Dec. 20, 2021
Spectrum Analyzer KEYSIGHT	N9020B	MY60110513	Dec. 21, 2020	Dec. 20, 2021
BILOG Antenna SCHWARZBECK	VULB9168	1214	Nov. 04, 2020 Oct. 28, 2021	Nov. 03, 2021 Oct. 27, 2022
HORN Antenna SCHWARZBECK	BBHA 9120 D	9120D-1170	Nov. 22, 2020	Nov. 21, 2021
HORN Antenna SCHWARZBECK	BBHA 9170	995	Nov. 22, 2020	Nov. 21, 2021
Preamplifier EMCI	EMC330N	980798	Jan. 12, 2021	Jan. 11, 2022
Preamplifier EMCI	EMC118A45SE	980809	Jan. 12, 2021	Jan. 11, 2022
Preamplifier EMCI	EMC184045SE	980786	Jan. 12, 2021	Jan. 11, 2022
RF signal cable EMCI	EMC104-SM-SM- (9000+2000+1000)	201244+ 201232+ 210103	Jan. 12, 2021	Jan. 11, 2022
RF signal cable EMCI	EMCCFD400-NM- NM- (9000+300+500)	201251+ 201249+ 201248	Jan. 12, 2021	Jan. 11, 2022
RF signal cable EMCI	EMC101G-KM-KM- (5000+3000+2000)	201261+201258+20124 9	Jan. 12, 2021	Jan. 11, 2022
Software BV ADT	ADT_Radiated_V7. 6.15.9.5	NA	NA	NA
Antenna Tower Max-Full	MFA-515BSN	NA	NA	NA
Turn Table Max-Full	MFT-201SS	NA	NA	NA
Turn Table Controller Max-Full	MF-7802BS	MF780208676	NA	NA
Peak Power Analyzer KEYSIGHT	8990B	MY51000485	Jan. 19, 2021	Jan. 18, 2022
Wideband Power Sensor KEYSIGHT	N1923A	MY58020002	Jan. 11, 2021	Jan. 10, 2022

- Note: 1. The calibration interval of the above test instruments is 12 months and the calibrations are traceable to NML/ROC and NIST/USA.
 2. The test was performed in WM Chamber 9.

4.1.3 Test Procedure

For Radiated emission below 30MHz

- a. The EUT was placed on the top of a rotating table 0.8 meters above the ground at a 3 meter chamber room. The table was rotated 360 degrees to determine the position of the highest radiation.
- b. The EUT was set 3 meters away from the interference-receiving antenna, which was mounted on the top of a variable-height antenna tower.
- c. Parallel, perpendicular, and ground-parallel orientations of the antenna are set to make the measurement.
- d. For each suspected emission, the EUT was arranged to its worst case and the rotatable table was turned from 0 degrees to 360 degrees to find the maximum reading.
- e. The test-receiver system was set to Quasi-Peak Detect Function and Specified Bandwidth with Maximum Hold Mode.

NOTE:

1. The resolution bandwidth and video bandwidth of test receiver/spectrum analyzer is 9kHz at frequency below 30MHz.

For Radiated emission above 30MHz

- a. The EUT was placed on the top of a rotating table 0.8 meters (for 30MHz ~ 1GHz) / 1.5 meters (for above 1GHz) above the ground at 3 meter chamber room for test. The table was rotated 360 degrees to determine the position of the highest radiation.
- b. The EUT was set 3 meters away from the interference-receiving antenna, which was mounted on the top of a variable-height antenna tower.
- c. The height of antenna is varied from one meter to four meters above the ground to determine the maximum value of the field strength. Both horizontal and vertical polarizations of the antenna are set to make the measurement.
- d. For each suspected emission, the EUT was arranged to its worst case and then the antenna was tuned to heights from 1 meter to 4 meters and the rotatable table was turned from 0 degrees to 360 degrees to find the maximum reading.
- e. The test-receiver system was set to quasi-peak detect function and specified bandwidth with maximum hold mode when the test frequency is below 1 GHz.
- f. The test-receiver system was set to peak detects function and specified bandwidth with maximum hold mode when the test frequency is above 1 GHz. If the peak reading value also meets average limit, measurement with the RMS detector is unnecessary.
- g. When operating in U-NII-4 OOB and spurious emissions are to be measured outside of the 5725-5895 MHz band. Below 5725 MHz the -27 dBm EIRP is measured with a Peak detector and above 5895 MHz it is measured with an RMS detector. If the -27 dBm EIRP limit is met with a Peak detector retesting with an RMS detector is not required.

Note:

1. The resolution bandwidth and video bandwidth of test receiver/spectrum analyzer is 120kHz for Quasi-peak detection (QP) at frequency below 1GHz.
2. The resolution bandwidth of test receiver/spectrum analyzer is 1 MHz and the video bandwidth is 3 MHz for Peak detection (PK) at frequency above 1GHz.
3. The detection is peak and the resolution bandwidth of test receiver/spectrum analyzer is 1MHz and the video bandwidth is $\geq 1/T$ (Duty cycle < 98%) or 10Hz (Duty cycle $\geq 98\%$) for Average measurement (AV)

at frequency above 1GHz.

4. All modes of operation were investigated and the worst-case emissions are reported.

4.1.4 Test Setup

For Radiated emission below 30MHz

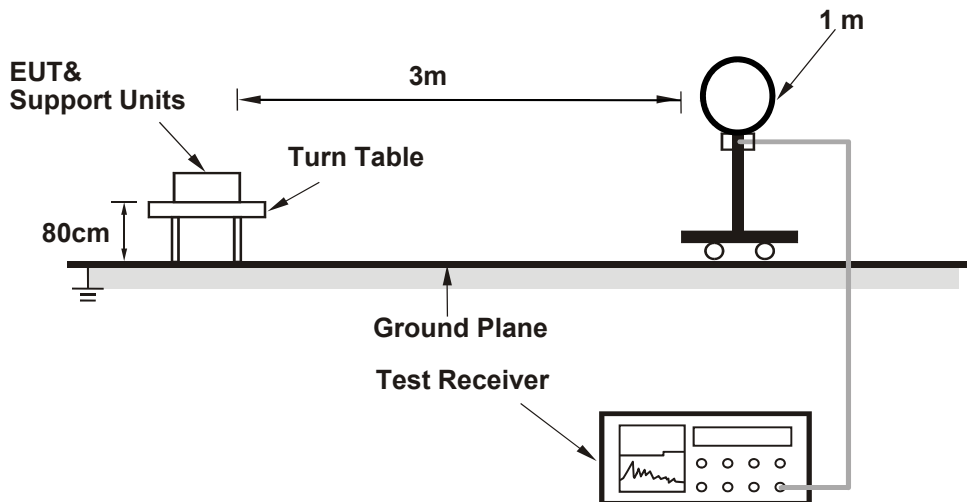

For Radiated emission 30MHz to 1GHz

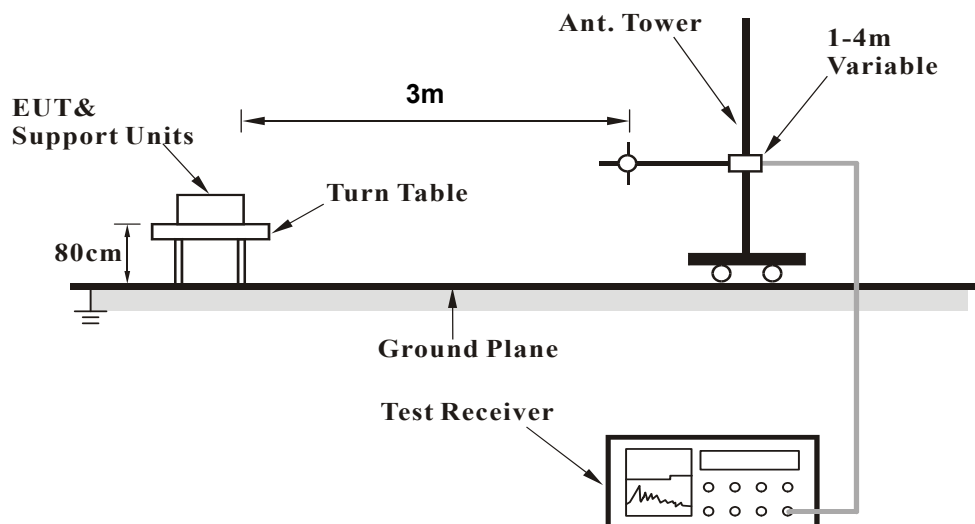

For Radiated emission above 1GHz

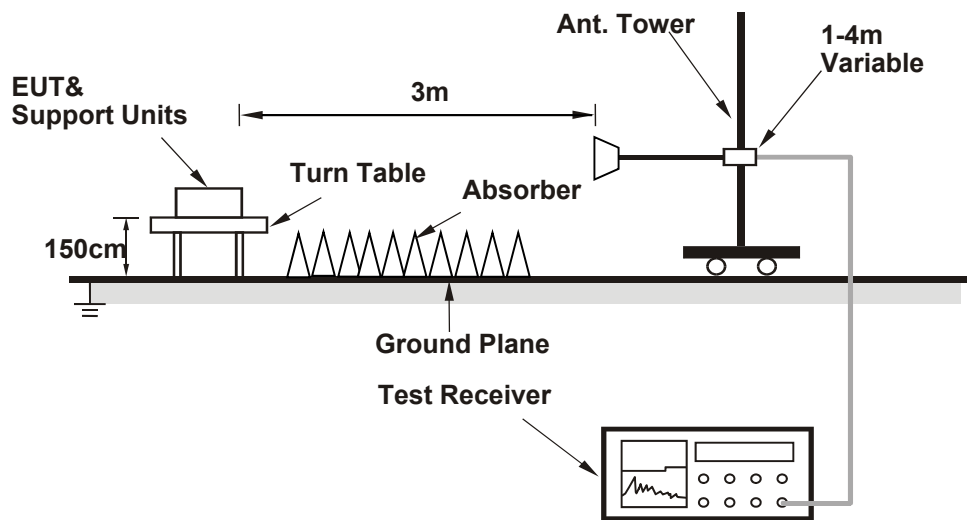

For the actual test configuration, please refer to the attached file (Test Setup Photo).

4.1.5 EUT Operating Condition

- Placed the EUT on the testing table.
- Prepared a notebook to act as a communication partner and placed it outside of testing area.
- The communication partner connected with EUT via a RJ45 cable and ran a test program (provided by manufacturer) to enable EUT under transmission condition continuously at specific channel frequency.
- The communication partner sent data to EUT by command "PING".

4.1.6 Test Results

Above 1GHz Data:

RF Mode	TX 802.11a	Channel	CH 169 : 5845 MHz
Frequency Range	1GHz ~ 40GHz	Detector Function	Peak (PK) Average (AV)

Antenna Polarity & Test Distance : Horizontal at 3 m								
No	Frequency (MHz)	Emission Level (dBuV/m)	Limit (dBuV/m)	Margin (dB)	Antenna Height (m)	Table Angle (Degree)	Raw Value (dBuV)	Correction Factor (dB/m)
1	#5571.85	57.0 PK	68.2	-11.2	2.16 H	346	54.6	2.4
2	*5845.00	115.0 PK			2.16 H	346	73.4	41.6
3	*5845.00	106.7 AV			2.16 H	346	65.1	41.6
4	#5915.75	59.1 PK	95.0	-35.9	2.16 H	346	55.6	3.5
5	#5971.32	57.5 PK	88.2	-30.7	2.16 H	346	53.9	3.6
6	11690.00	56.9 PK	74.0	-17.1	2.87 H	192	48.1	8.8
7	11690.00	45.5 AV	54.0	-8.5	2.87 H	192	36.7	8.8
8	#17535.00	63.2 PK	88.2	-25.0	2.88 H	171	53.2	10.0

Antenna Polarity & Test Distance : Vertical at 3 m								
No	Frequency (MHz)	Emission Level (dBuV/m)	Limit (dBuV/m)	Margin (dB)	Antenna Height (m)	Table Angle (Degree)	Raw Value (dBuV)	Correction Factor (dB/m)
1	#5648.80	58.3 PK	68.2	-9.9	1.67 V	190	55.4	2.9
2	*5845.00	125.1 PK			1.67 V	190	83.5	41.6
3	*5845.00	116.7 AV			1.67 V	190	75.1	41.6
4	#5901.50	61.1 PK	105.4	-44.3	1.67 V	190	57.7	3.4
5	#5992.70	58.1 PK	88.2	-30.1	1.67 V	190	54.4	3.7
6	11690.00	56.4 PK	74.0	-17.6	1.51 V	308	47.6	8.8
7	11690.00	46.7 AV	54.0	-7.3	1.51 V	308	37.9	8.8
8	#17535.00	63.9 PK	88.2	-24.3	2.90 V	353	53.9	10.0

Remarks:

1. Emission Level(dBuV/m) = Raw Value(dBuV) + Correction Factor(dB/m)
2. Correction Factor(dB/m) = Antenna Factor(dB/m) + Cable Factor(dB) – Pre-Amplifier Factor(dB)
3. Margin value = Emission Level – Limit value
4. The other emission levels were very low against the limit.
5. " * " : Fundamental frequency.
6. " # " : The radiated frequency is out of the restricted band.

RF Mode	TX 802.11a	Channel	CH 173 : 5865 MHz
Frequency Range	1GHz ~ 40GHz	Detector Function	Peak (PK) Average (AV)

Antenna Polarity & Test Distance : Horizontal at 3 m

No	Frequency (MHz)	Emission Level (dBuV/m)	Limit (dBuV/m)	Margin (dB)	Antenna Height (m)	Table Angle (Degree)	Raw Value (dBuV)	Correction Factor (dB/m)
1	#5559.98	56.3 PK	68.2	-11.9	2.47 H	349	53.9	2.4
2	*5865.00	114.1 PK			2.47 H	349	72.5	41.6
3	*5865.00	105.6 AV			2.47 H	349	64.0	41.6
4	#5900.07	63.3 PK	106.5	-43.2	2.47 H	349	59.9	3.4
5	#6005.05	58.2 PK	88.2	-30.0	2.47 H	349	54.4	3.8
6	11730.00	56.0 PK	74.0	-18.0	2.69 H	199	47.3	8.7
7	11730.00	47.7 AV	54.0	-6.3	2.69 H	199	39.0	8.7
8	#17595.00	69.7 PK	88.2	-18.5	2.88 H	163	60.1	9.6

Antenna Polarity & Test Distance : Vertical at 3 m

No	Frequency (MHz)	Emission Level (dBuV/m)	Limit (dBuV/m)	Margin (dB)	Antenna Height (m)	Table Angle (Degree)	Raw Value (dBuV)	Correction Factor (dB/m)
1	#5556.65	56.3 PK	68.2	-11.9	1.59 V	183	53.9	2.4
2	*5865.00	125.0 PK			1.59 V	183	83.4	41.6
3	*5865.00	116.6 AV			1.59 V	183	75.0	41.6
4	#5904.35	70.4 PK	103.3	-32.9	1.59 V	183	67.0	3.4
5	#5929.05	58.5 PK	88.2	-29.7	1.59 V	183	55.0	3.5
6	11730.00	57.4 PK	74.0	-16.6	2.89 V	145	48.7	8.7
7	11730.00	47.9 AV	54.0	-6.1	2.89 V	145	39.2	8.7
8	#17595.00	70.5 PK	88.2	-17.7	3.07 V	355	60.9	9.6

Remarks:

1. Emission Level(dBuV/m) = Raw Value(dBuV) + Correction Factor(dB/m)
2. Correction Factor(dB/m) = Antenna Factor(dB/m) + Cable Factor(dB) – Pre-Amplifier Factor(dB)
3. Margin value = Emission Level – Limit value
4. The other emission levels were very low against the limit.
5. " * ": Fundamental frequency.
6. " # ": The radiated frequency is out of the restricted band.

RF Mode	TX 802.11a	Channel	CH 177 : 5885 MHz
Frequency Range	1GHz ~ 40GHz	Detector Function	Peak (PK) Average (AV)

Antenna Polarity & Test Distance : Horizontal at 3 m

No	Frequency (MHz)	Emission Level (dBuV/m)	Limit (dBuV/m)	Margin (dB)	Antenna Height (m)	Table Angle (Degree)	Raw Value (dBuV)	Correction Factor (dB/m)
1	#5613.65	56.7 PK	68.2	-11.5	2.49 H	334	54.0	2.7
2	*5885.00	113.7 PK			2.49 H	334	72.1	41.6
3	*5885.00	105.6 AV			2.49 H	334	64.0	41.6
4	#5901.02	81.4 PK	105.8	-24.4	2.49 H	334	78.0	3.4
5	#5925.73	62.7 PK	88.2	-25.5	2.49 H	334	59.2	3.5
6	11770.00	56.0 PK	74.0	-18.0	2.71 H	136	47.2	8.8
7	11770.00	46.6 AV	54.0	-7.4	2.71 H	136	37.8	8.8
8	#17655.00	68.6 PK	88.2	-19.6	2.90 H	173	58.8	9.8

Antenna Polarity & Test Distance : Vertical at 3 m

No	Frequency (MHz)	Emission Level (dBuV/m)	Limit (dBuV/m)	Margin (dB)	Antenna Height (m)	Table Angle (Degree)	Raw Value (dBuV)	Correction Factor (dB/m)
1	#5637.87	57.2 PK	68.2	-11.0	1.71 V	183	54.3	2.9
2	*5885.00	125.0 PK			1.71 V	183	83.4	41.6
3	*5885.00	116.7 AV			1.71 V	183	75.1	41.6
4	#5899.60	92.7 PK	106.8	-14.1	1.71 V	183	89.3	3.4
5	#5927.62	65.1 PK	88.2	-23.1	1.71 V	183	61.6	3.5
6	11770.00	56.7 PK	74.0	-17.3	1.36 V	271	47.9	8.8
7	11770.00	47.1 AV	54.0	-6.9	1.36 V	271	38.3	8.8
8	#17655.00	70.4 PK	88.2	-17.8	3.17 V	343	60.6	9.8

Remarks:

1. Emission Level(dBuV/m) = Raw Value(dBuV) + Correction Factor(dB/m)
2. Correction Factor(dB/m) = Antenna Factor(dB/m) + Cable Factor(dB) – Pre-Amplifier Factor(dB)
3. Margin value = Emission Level – Limit value
4. The other emission levels were very low against the limit.
5. " * ": Fundamental frequency.
6. " # ": The radiated frequency is out of the restricted band.

RF Mode	TX 802.11ax (HE20)	Channel	CH 169 : 5845 MHz
Frequency Range	1GHz ~ 40GHz	Detector Function	Peak (PK) Average (AV)

Antenna Polarity & Test Distance : Horizontal at 3 m								
No	Frequency (MHz)	Emission Level (dBuV/m)	Limit (dBuV/m)	Margin (dB)	Antenna Height (m)	Table Angle (Degree)	Raw Value (dBuV)	Correction Factor (dB/m)
1	#5616.02	56.8 PK	68.2	-11.4	2.38 H	334	54.1	2.7
2	*5845.00	115.1 PK			2.38 H	334	73.5	41.6
3	*5845.00	105.2 AV			2.38 H	334	63.6	41.6
4	#5905.30	56.6 PK	102.6	-46.0	2.38 H	334	53.2	3.4
5	#5945.68	58.5 PK	88.2	-29.7	2.38 H	334	54.9	3.6
6	11690.00	56.0 PK	74.0	-18.0	2.77 H	186	47.2	8.8
7	11690.00	45.9 AV	54.0	-8.1	2.77 H	186	37.1	8.8
8	#17535.00	68.5 PK	88.2	-19.7	2.75 H	168	58.5	10.0

Antenna Polarity & Test Distance : Vertical at 3 m								
No	Frequency (MHz)	Emission Level (dBuV/m)	Limit (dBuV/m)	Margin (dB)	Antenna Height (m)	Table Angle (Degree)	Raw Value (dBuV)	Correction Factor (dB/m)
1	#5647.85	56.7 PK	68.2	-11.5	1.67 V	168	53.8	2.9
2	*5845.00	125.8 PK			1.67 V	168	84.2	41.6
3	*5845.00	116.5 AV			1.67 V	168	74.9	41.6
4	#5904.82	62.0 PK	103.0	-41.0	1.67 V	168	58.6	3.4
5	#5998.87	57.8 PK	88.2	-30.4	1.67 V	168	54.0	3.8
6	11690.00	56.8 PK	74.0	-17.2	1.46 V	320	48.0	8.8
7	11690.00	46.4 AV	54.0	-7.6	1.46 V	320	37.6	8.8
8	#17535.00	69.6 PK	88.2	-18.6	3.11 V	345	59.6	10.0

Remarks:

1. Emission Level(dBuV/m) = Raw Value(dBuV) + Correction Factor(dB/m)
2. Correction Factor(dB/m) = Antenna Factor(dB/m) + Cable Factor(dB) – Pre-Amplifier Factor(dB)
3. Margin value = Emission Level – Limit value
4. The other emission levels were very low against the limit.
5. " * " : Fundamental frequency.
6. " # " : The radiated frequency is out of the restricted band.

RF Mode	TX 802.11ax (HE20)	Channel	CH 173 : 5865 MHz
Frequency Range	1GHz ~ 40GHz	Detector Function	Peak (PK) Average (AV)

Antenna Polarity & Test Distance : Horizontal at 3 m

No	Frequency (MHz)	Emission Level (dBuV/m)	Limit (dBuV/m)	Margin (dB)	Antenna Height (m)	Table Angle (Degree)	Raw Value (dBuV)	Correction Factor (dB/m)
1	#5618.40	56.3 PK	68.2	-11.9	2.29 H	334	53.6	2.7
2	*5865.00	114.6 PK			2.29 H	334	73.0	41.6
3	*5865.00	105.1 AV			2.29 H	334	63.5	41.6
4	#5898.65	65.4 PK	107.5	-42.1	2.29 H	334	62.0	3.4
5	#5941.40	55.9 PK	88.2	-32.3	2.29 H	334	52.4	3.5
6	11730.00	55.8 PK	74.0	-18.2	2.93 H	195	47.1	8.7
7	11730.00	46.2 AV	54.0	-7.8	2.93 H	195	37.5	8.7
8	#17595.00	66.5 PK	88.2	-21.7	2.81 H	163	56.9	9.6

Antenna Polarity & Test Distance : Vertical at 3 m

No	Frequency (MHz)	Emission Level (dBuV/m)	Limit (dBuV/m)	Margin (dB)	Antenna Height (m)	Table Angle (Degree)	Raw Value (dBuV)	Correction Factor (dB/m)
1	#5588.95	57.9 PK	68.2	-10.3	1.84 V	171	55.3	2.6
2	*5865.00	125.2 PK			1.84 V	171	83.6	41.6
3	*5865.00	116.2 AV			1.84 V	171	74.6	41.6
4	#5898.65	72.3 PK	107.5	-35.2	1.84 V	171	68.9	3.4
5	#5933.32	49.5 PK	88.2	-38.7	1.84 V	171	46.0	3.5
6	11730.00	56.1 PK	74.0	-17.9	1.36 V	319	47.4	8.7
7	11730.00	46.3 AV	54.0	-7.7	1.36 V	319	37.6	8.7
8	#17595.00	67.9 PK	88.2	-20.3	2.98 V	312	58.3	9.6

Remarks:

1. Emission Level(dBuV/m) = Raw Value(dBuV) + Correction Factor(dB/m)
2. Correction Factor(dB/m) = Antenna Factor(dB/m) + Cable Factor(dB) – Pre-Amplifier Factor(dB)
3. Margin value = Emission Level – Limit value
4. The other emission levels were very low against the limit.
5. " * ": Fundamental frequency.
6. " # ": The radiated frequency is out of the restricted band.

RF Mode	TX 802.11ax (HE20)	Channel	CH 177 : 5885 MHz
Frequency Range	1GHz ~ 40GHz	Detector Function	Peak (PK) Average (AV)

Antenna Polarity & Test Distance : Horizontal at 3 m

No	Frequency (MHz)	Emission Level (dBuV/m)	Limit (dBuV/m)	Margin (dB)	Antenna Height (m)	Table Angle (Degree)	Raw Value (dBuV)	Correction Factor (dB/m)
1	#5594.65	56.5 PK	68.2	-11.7	2.10 H	334	53.9	2.6
2	*5885.00	115.7 PK			2.10 H	334	74.1	41.6
3	*5885.00	105.8 AV			2.10 H	334	64.2	41.6
4	#5904.82	80.9 PK	103.0	-22.1	2.10 H	334	77.5	3.4
5	#5927.62	59.4 PK	88.2	-28.8	2.10 H	334	55.9	3.5
6	11770.00	56.5 PK	74.0	-17.5	2.86 H	185	47.7	8.8
7	11770.00	47.3 AV	54.0	-6.7	2.86 H	185	38.5	8.8
8	#17655.00	66.9 PK	88.2	-21.3	2.93 H	159	57.1	9.8

Antenna Polarity & Test Distance : Vertical at 3 m

No	Frequency (MHz)	Emission Level (dBuV/m)	Limit (dBuV/m)	Margin (dB)	Antenna Height (m)	Table Angle (Degree)	Raw Value (dBuV)	Correction Factor (dB/m)
1	#5554.75	56.7 PK	68.2	-11.5	1.85 V	169	54.3	2.4
2	*5885.00	125.5 PK			1.85 V	169	83.9	41.6
3	*5885.00	115.8 AV			1.85 V	169	74.2	41.6
4	#5901.98	93.8 PK	105.1	-11.3	1.85 V	169	90.4	3.4
5	#5925.25	70.6 PK	88.2	-17.6	1.85 V	169	67.1	3.5
6	11770.00	56.9 PK	74.0	-17.1	1.39 V	322	48.1	8.8
7	11770.00	47.5 AV	54.0	-6.5	1.39 V	322	38.7	8.8
8	#17655.00	68.2 PK	88.2	-20.0	3.12 V	341	58.4	9.8

Remarks:

1. Emission Level(dBuV/m) = Raw Value(dBuV) + Correction Factor(dB/m)
2. Correction Factor(dB/m) = Antenna Factor(dB/m) + Cable Factor(dB) – Pre-Amplifier Factor(dB)
3. Margin value = Emission Level – Limit value
4. The other emission levels were very low against the limit.
5. " * ": Fundamental frequency.
6. " # ": The radiated frequency is out of the restricted band.

RF Mode	TX 802.11ax (HE40)	Channel	CH 167 : 5835 MHz
Frequency Range	1GHz ~ 40GHz	Detector Function	Peak (PK) Average (AV)

Antenna Polarity & Test Distance : Horizontal at 3 m								
No	Frequency (MHz)	Emission Level (dBuV/m)	Limit (dBuV/m)	Margin (dB)	Antenna Height (m)	Table Angle (Degree)	Raw Value (dBuV)	Correction Factor (dB/m)
1	#5622.68	58.3 PK	68.2	-9.9	1.90 H	342	55.6	2.7
2	*5835.00	113.5 PK			1.90 H	342	71.9	41.6
3	*5835.00	103.7 AV			1.90 H	342	62.1	41.6
4	#5899.12	67.9 PK	107.2	-39.3	1.90 H	342	64.5	3.4
5	#5928.10	58.8 PK	88.2	-29.4	1.90 H	342	55.3	3.5
6	11670.00	56.4 PK	74.0	-17.6	2.91 H	175	47.6	8.8
7	11670.00	46.3 AV	54.0	-7.7	2.91 H	175	37.5	8.8

Antenna Polarity & Test Distance : Vertical at 3 m								
No	Frequency (MHz)	Emission Level (dBuV/m)	Limit (dBuV/m)	Margin (dB)	Antenna Height (m)	Table Angle (Degree)	Raw Value (dBuV)	Correction Factor (dB/m)
1	#5645.95	60.2 PK	68.2	-8.0	1.70 V	186	57.3	2.9
2	*5835.00	124.3 PK			1.70 V	186	82.7	41.6
3	*5835.00	113.5 AV			1.70 V	186	71.9	41.6
4	#5906.25	77.0 PK	101.9	-24.9	1.70 V	186	73.6	3.4
5	#5928.57	66.2 PK	88.2	-22.0	1.70 V	186	62.7	3.5
6	11670.00	56.9 PK	74.0	-17.1	1.46 V	301	48.1	8.8
7	11670.00	46.5 AV	54.0	-7.5	1.46 V	301	37.7	8.8

Remarks:

1. Emission Level(dBuV/m) = Raw Value(dBuV) + Correction Factor(dB/m)
2. Correction Factor(dB/m) = Antenna Factor(dB/m) + Cable Factor(dB) – Pre-Amplifier Factor(dB)
3. Margin value = Emission Level – Limit value
4. The other emission levels were very low against the limit.
5. " * ": Fundamental frequency.
6. " # ": The radiated frequency is out of the restricted band.

RF Mode	TX 802.11ax (HE40)	Channel	CH 175 : 5875 MHz
Frequency Range	1GHz ~ 40GHz	Detector Function	Peak (PK) Average (AV)

Antenna Polarity & Test Distance : Horizontal at 3 m

No	Frequency (MHz)	Emission Level (dBuV/m)	Limit (dBuV/m)	Margin (dB)	Antenna Height (m)	Table Angle (Degree)	Raw Value (dBuV)	Correction Factor (dB/m)
1	#5640.25	57.5 PK	68.2	-10.7	1.83 H	340	54.6	2.9
2	*5875.00	112.1 PK			1.83 H	340	70.5	41.6
3	*5875.00	102.6 AV			1.83 H	340	61.0	41.6
4	#5900.07	87.1 PK	106.5	-19.4	1.83 H	340	83.7	3.4
5	#5930.00	69.1 PK	88.2	-19.1	1.83 H	340	65.6	3.5
6	11750.00	56.2 PK	74.0	-17.8	2.63 H	173	47.5	8.7
7	11750.00	45.8 AV	54.0	-8.2	2.63 H	173	37.1	8.7

Antenna Polarity & Test Distance : Vertical at 3 m

No	Frequency (MHz)	Emission Level (dBuV/m)	Limit (dBuV/m)	Margin (dB)	Antenna Height (m)	Table Angle (Degree)	Raw Value (dBuV)	Correction Factor (dB/m)
1	#5641.68	56.7 PK	68.2	-11.5	1.78 V	173	53.8	2.9
2	*5875.00	123.1 PK			1.78 V	173	81.5	41.6
3	*5875.00	113.9 AV			1.78 V	173	72.3	41.6
4	#5906.73	94.3 PK	101.6	-7.3	1.78 V	173	90.9	3.4
5	#5917.65	91.7 PK	93.6	-1.9	1.78 V	173	88.2	3.5
6	#5926.20	81.0 PK	88.2	-7.2	1.78 V	173	77.5	3.5
7	11750.00	56.5 PK	74.0	-17.5	1.62 V	298	47.8	8.7
8	11750.00	46.5 AV	54.0	-7.5	1.62 V	298	37.8	8.7

Remarks:

1. Emission Level(dBuV/m) = Raw Value(dBuV) + Correction Factor(dB/m)
2. Correction Factor(dB/m) = Antenna Factor(dB/m) + Cable Factor(dB) – Pre-Amplifier Factor(dB)
3. Margin value = Emission Level – Limit value
4. The other emission levels were very low against the limit.
5. " * ": Fundamental frequency.
6. " # ": The radiated frequency is out of the restricted band.

RF Mode	TX 802.11ax (HE80)	Channel	CH 171 : 5855 MHz
Frequency Range	1GHz ~ 40GHz	Detector Function	Peak (PK) Average (AV)

Antenna Polarity & Test Distance : Horizontal at 3 m

No	Frequency (MHz)	Emission Level (dBuV/m)	Limit (dBuV/m)	Margin (dB)	Antenna Height (m)	Table Angle (Degree)	Raw Value (dBuV)	Correction Factor (dB/m)
1	#5621.25	57.0 PK	68.2	-11.2	1.91 H	331	54.3	2.7
2	*5855.00	108.3 PK			1.91 H	331	66.7	41.6
3	*5855.00	99.8 AV			1.91 H	331	58.2	41.6
4	#5906.73	75.7 PK	101.6	-25.9	1.91 H	331	72.3	3.4
5	#5925.00	73.9 PK	88.2	-14.3	1.91 H	331	70.4	3.5
6	#5927.15	70.6 PK	88.2	-17.6	1.91 H	331	67.1	3.5
7	11710.00	55.9 PK	74.0	-18.1	2.76 H	186	47.2	8.7
8	11710.00	45.8 AV	54.0	-8.2	2.76 H	186	37.1	8.7

Antenna Polarity & Test Distance : Vertical at 3 m

No	Frequency (MHz)	Emission Level (dBuV/m)	Limit (dBuV/m)	Margin (dB)	Antenna Height (m)	Table Angle (Degree)	Raw Value (dBuV)	Correction Factor (dB/m)
1	#5640.25	58.4 PK	68.2	-9.8	1.51 V	173	55.5	2.9
2	*5855.00	120.5 PK			1.51 V	173	78.9	41.6
3	*5855.00	110.1 AV			1.51 V	173	68.5	41.6
4	#5914.80	89.3 PK	95.7	-6.4	1.51 V	173	85.8	3.5
5	#5925.00	87.2 PK	88.2	-1.0	1.51 V	173	83.7	3.5
6	#5928.57	84.4 PK	88.2	-3.8	1.51 V	173	80.9	3.5
7	11710.00	56.5 PK	74.0	-17.5	1.62 V	326	47.8	8.7
8	11710.00	46.3 AV	54.0	-7.7	1.62 V	326	37.6	8.7

Remarks:

1. Emission Level(dBuV/m) = Raw Value(dBuV) + Correction Factor(dB/m)
2. Correction Factor(dB/m) = Antenna Factor(dB/m) + Cable Factor(dB) – Pre-Amplifier Factor(dB)
3. Margin value = Emission Level – Limit value
4. The other emission levels were very low against the limit.
5. " * ": Fundamental frequency.
6. " # ": The radiated frequency is out of the restricted band.

RF Mode	TX 802.11ax (HE160)	Channel	CH 163 : 5815 MHz
Frequency Range	1GHz ~ 40GHz	Detector Function	Peak (PK) Average (AV)

Antenna Polarity & Test Distance : Horizontal at 3 m

No	Frequency (MHz)	Emission Level (dBuV/m)	Limit (dBuV/m)	Margin (dB)	Antenna Height (m)	Table Angle (Degree)	Raw Value (dBuV)	Correction Factor (dB/m)
1	#5641.20	57.4 PK	68.2	-10.8	1.93 H	342	54.5	2.9
2	*5815.00	101.9 PK			1.93 H	342	60.3	41.6
3	*5815.00	92.8 AV			1.93 H	342	51.2	41.6
4	#5900.55	63.3 PK	106.1	-42.8	1.93 H	342	59.9	3.4
5	#5925.00	60.4 PK	88.2	-27.8	1.93 H	342	56.9	3.5
6	#5931.43	59.6 PK	88.2	-28.6	1.93 H	342	56.1	3.5
7	11630.00	55.7 PK	74.0	-18.3	2.77 H	172	46.9	8.8
8	11630.00	45.9 AV	54.0	-8.1	2.77 H	172	37.1	8.8

Antenna Polarity & Test Distance : Vertical at 3 m

No	Frequency (MHz)	Emission Level (dBuV/m)	Limit (dBuV/m)	Margin (dB)	Antenna Height (m)	Table Angle (Degree)	Raw Value (dBuV)	Correction Factor (dB/m)
1	#5646.43	64.5 PK	68.2	-3.7	1.68 V	189	61.6	2.9
2	*5815.00	114.0 PK			1.68 V	189	72.4	41.6
3	*5815.00	103.1 AV			1.68 V	189	61.5	41.6
4	#5906.25	68.7 PK	101.9	-33.2	1.68 V	189	65.3	3.4
5	#5925.00	68.9 PK	88.2	-19.3	1.68 V	189	65.4	3.5
6	#5928.10	66.6 PK	88.2	-21.6	1.68 V	189	63.1	3.5
7	11630.00	56.2 PK	74.0	-17.8	1.44 V	314	47.4	8.8
8	11630.00	46.0 AV	54.0	-8.0	1.44 V	314	37.2	8.8

Remarks:

1. Emission Level(dBuV/m) = Raw Value(dBuV) + Correction Factor(dB/m)
2. Correction Factor(dB/m) = Antenna Factor(dB/m) + Cable Factor(dB) – Pre-Amplifier Factor(dB)
3. Margin value = Emission Level – Limit value
4. The other emission levels were very low against the limit.
5. " * ": Fundamental frequency.
6. " # ": The radiated frequency is out of the restricted band.

Below 1GHz Data:

RF Mode	TX 802.11ax (HE160)	Channel	CH 163 : 5815 MHz
Frequency Range	30MHz ~ 1GHz	Detector Function	Quasi-Peak (QP)
Test Mode	A		

ANTENNA POLARITY & TEST DISTANCE: HORIZONTAL AT 3 M								
NO.	FREQ. (MHz)	EMISSION LEVEL (dBuV/m)	LIMIT (dBuV/m)	MARGIN (dB)	ANTENNA HEIGHT (m)	TABLE ANGLE (Degree)	RAW VALUE (dBuV)	CORRECTION FACTOR (dB/m)
1	48.28	20.7 QP	40.0	-19.3	2.00 H	268	38.9	-18.2
2	159.33	23.9 QP	43.5	-19.6	2.00 H	218	42.2	-18.3
3	256.33	18.6 QP	46.0	-27.4	1.51 H	3	38.1	-19.5
4	297.10	17.5 QP	46.0	-28.5	1.01 H	340	35.4	-17.9
5	479.86	23.6 QP	46.0	-22.4	2.00 H	61	37.1	-13.5
6	777.88	24.1 QP	46.0	-21.9	2.00 H	265	32.1	-8.0

Remarks:

1. Emission Level(dBuV/m) = Raw Value(dBuV) + Correction Factor(dB/m).
2. Correction Factor(dB/m) = Antenna Factor(dB/m) + Cable Factor(dB) – Pre-Amplifier Factor(dB).
3. The other emission levels were very low against the limit of frequency range 30MHz ~ 1000MHz.
4. Margin value = Emission Level – Limit value.
5. The emission levels were very low against the limit of frequency range 9kHz ~ 30MHz: the amplitude of spurious emissions attenuated more than 20 dB below the permissible value to be report.

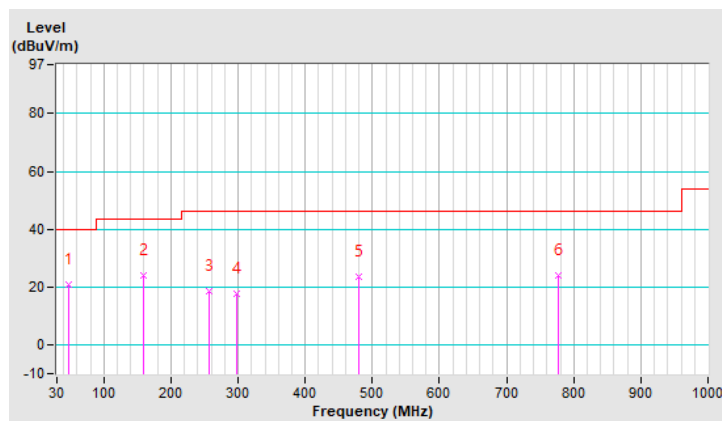

RF Mode	TX 802.11ax (HE160)	Channel	CH 163 : 5815 MHz
Frequency Range	30MHz ~ 1GHz	Detector Function	Quasi-Peak (QP)
Test Mode	A		

ANTENNA POLARITY & TEST DISTANCE: VERTICAL AT 3 M								
NO.	FREQ. (MHz)	EMISSION LEVEL (dBuV/m)	LIMIT (dBuV/m)	MARGIN (dB)	ANTENNA HEIGHT (m)	TABLE ANGLE (Degree)	RAW VALUE (dBuV)	CORRECTION FACTOR (dB/m)
1	48.28	35.1 QP	40.0	-4.9	1.00 V	323	53.3	-18.2
2	155.12	22.0 QP	43.5	-21.5	1.00 V	353	40.3	-18.3
3	254.93	24.2 QP	46.0	-21.8	1.49 V	259	43.7	-19.5
4	297.10	25.9 QP	46.0	-20.1	1.49 V	351	43.8	-17.9
5	479.86	26.4 QP	46.0	-19.6	1.00 V	17	39.9	-13.5
6	559.99	24.2 QP	46.0	-21.8	1.00 V	153	36.2	-12.0

Remarks:

1. Emission Level(dBuV/m) = Raw Value(dBuV) + Correction Factor(dB/m).
2. Correction Factor(dB/m) = Antenna Factor(dB/m) + Cable Factor(dB) – Pre-Amplifier Factor(dB).
3. The other emission levels were very low against the limit of frequency range 30MHz ~ 1000MHz.
4. Margin value = Emission Level – Limit value.
5. The emission levels were very low against the limit of frequency range 9kHz ~ 30MHz: the amplitude of spurious emissions attenuated more than 20 dB below the permissible value to be report.

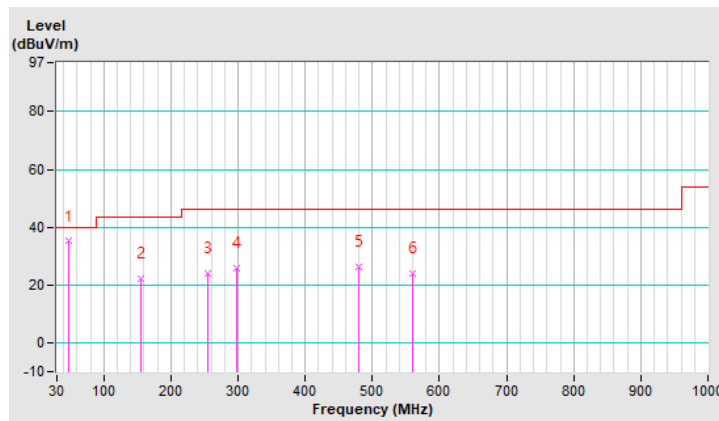

RF Mode	TX 802.11ax (HE160)	Channel	CH 163 : 5815 MHz
Frequency Range	30MHz ~ 1GHz	Detector Function	Quasi-Peak (QP)
Test Mode	B		

ANTENNA POLARITY & TEST DISTANCE: HORIZONTAL AT 3 M								
NO.	FREQ. (MHz)	EMISSION LEVEL (dBuV/m)	LIMIT (dBuV/m)	MARGIN (dB)	ANTENNA HEIGHT (m)	TABLE ANGLE (Degree)	RAW VALUE (dBuV)	CORRECTION FACTOR (dB/m)
1	145.28	21.0 QP	43.5	-22.5	1.00 H	86	39.5	-18.5
2	256.33	19.0 QP	46.0	-27.0	1.50 H	356	38.5	-19.5
3	297.10	18.0 QP	46.0	-28.0	1.50 H	335	35.9	-17.9
4	479.86	20.6 QP	46.0	-25.4	1.50 H	16	34.1	-13.5
5	600.75	21.8 QP	46.0	-24.2	1.00 H	82	32.4	-10.6
6	782.10	27.5 QP	46.0	-18.5	1.50 H	218	35.6	-8.1

Remarks:

1. Emission Level(dBuV/m) = Raw Value(dBuV) + Correction Factor(dB/m).
2. Correction Factor(dB/m) = Antenna Factor(dB/m) + Cable Factor(dB) – Pre-Amplifier Factor(dB).
3. The other emission levels were very low against the limit of frequency range 30MHz ~ 1000MHz.
4. Margin value = Emission Level – Limit value.
5. The emission levels were very low against the limit of frequency range 9kHz ~ 30MHz: the amplitude of spurious emissions attenuated more than 20 dB below the permissible value to be report.

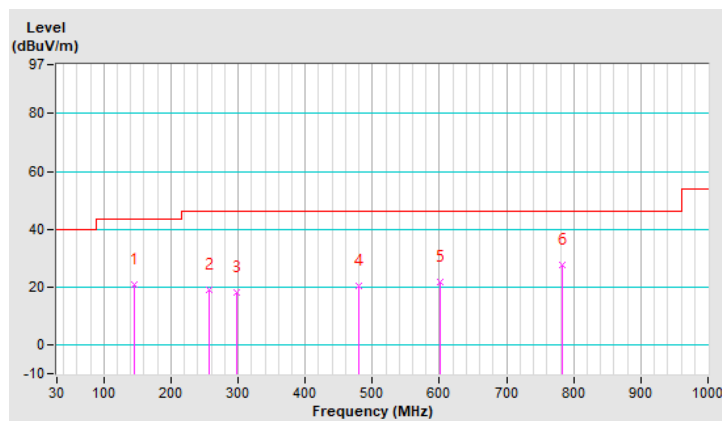

RF Mode	TX 802.11ax (HE160)	Channel	CH 163 : 5815 MHz
Frequency Range	30MHz ~ 1GHz	Detector Function	Quasi-Peak (QP)
Test Mode	B		

ANTENNA POLARITY & TEST DISTANCE: VERTICAL AT 3 M								
NO.	FREQ. (MHz)	EMISSION LEVEL (dBuV/m)	LIMIT (dBuV/m)	MARGIN (dB)	ANTENNA HEIGHT (m)	TABLE ANGLE (Degree)	RAW VALUE (dBuV)	CORRECTION FACTOR (dB/m)
1	52.49	21.2 QP	40.0	-18.8	1.00 V	342	39.5	-18.3
2	145.28	18.5 QP	43.5	-25.0	1.50 V	209	37.0	-18.5
3	254.93	22.4 QP	46.0	-23.6	1.50 V	257	41.9	-19.5
4	297.10	24.9 QP	46.0	-21.1	1.50 V	349	42.8	-17.9
5	479.86	25.1 QP	46.0	-20.9	1.50 V	352	38.6	-13.5
6	761.01	24.1 QP	46.0	-21.9	1.00 V	197	32.3	-8.2

Remarks:

1. Emission Level(dBuV/m) = Raw Value(dBuV) + Correction Factor(dB/m).
2. Correction Factor(dB/m) = Antenna Factor(dB/m) + Cable Factor(dB) – Pre-Amplifier Factor(dB).
3. The other emission levels were very low against the limit of frequency range 30MHz ~ 1000MHz.
4. Margin value = Emission Level – Limit value.
5. The emission levels were very low against the limit of frequency range 9kHz ~ 30MHz: the amplitude of spurious emissions attenuated more than 20 dB below the permissible value to be report.

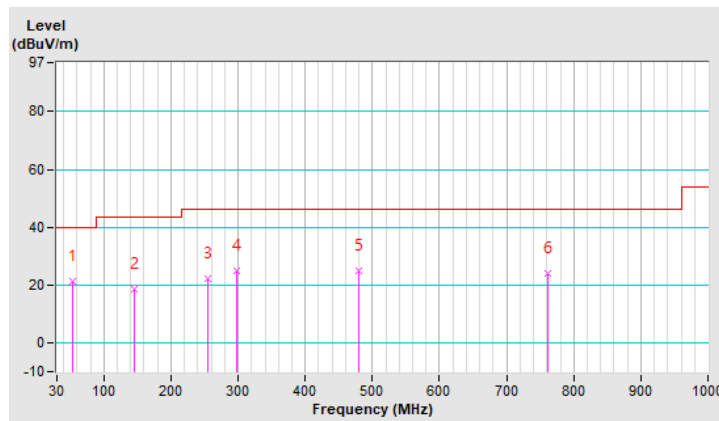

4.2 Conducted Emission Measurement

4.2.1 Limits of Conducted Emission Measurement

Frequency (MHz)	Conducted Limit (dBuV)	
	Quasi-peak	Average
0.15 - 0.5	66 - 56	56 - 46
0.50 - 5.0	56	46
5.0 - 30.0	60	50

Note: 1. The lower limit shall apply at the transition frequencies.

2. The limit decreases in line with the logarithm of the frequency in the range of 0.15 to 0.50MHz.

4.2.2 Test Instruments

Description & Manufacturer	Model No.	Serial No.	Cal. Date	Cal. Due
Test Receiver ROHDE & SCHWARZ	ESCI	100613	Dec. 04, 2020	Dec. 03, 2021
RF signal cable Woken	5D-FB	Cable-cond1-01	Jan. 16, 2021	Jan. 15, 2022
LISN ROHDE & SCHWARZ (EUT)	ENV216	101826	Feb. 25, 2021	Feb. 24, 2022
LISN ROHDE & SCHWARZ (Peripheral)	ESH3-Z5	100311	Sep. 07, 2021	Sep. 06, 2022
Software ADT	BV ADT_Cond_ V7.3.7.4	NA	NA	NA

Note: 1. The calibration interval of the above test instruments is 12 months and the calibrations are traceable to NML/ROC and NIST/USA.

2. The test was performed in HwaYa Shielded Room 1(Conduction 1).

3. The VCCI Site Registration No. is C-12040.

4.2.3 Test Procedure

- The EUT was placed 0.4 meters from the conducting wall of the shielded room with EUT being connected to the power mains through a line impedance stabilization network (LISN). Other support units were connected to the power mains through another LISN. The two LISNs provide 50 ohm/ 50uH of coupling impedance for the measuring instrument.
- Both lines of the power mains connected to the EUT were checked for maximum conducted interference.
- The frequency range from 150kHz to 30MHz was searched. Emission levels under (Limit - 20dB) was not recorded.

NOTE: All modes of operation were investigated and the worst-case emissions are reported.

4.2.4 Test Setup

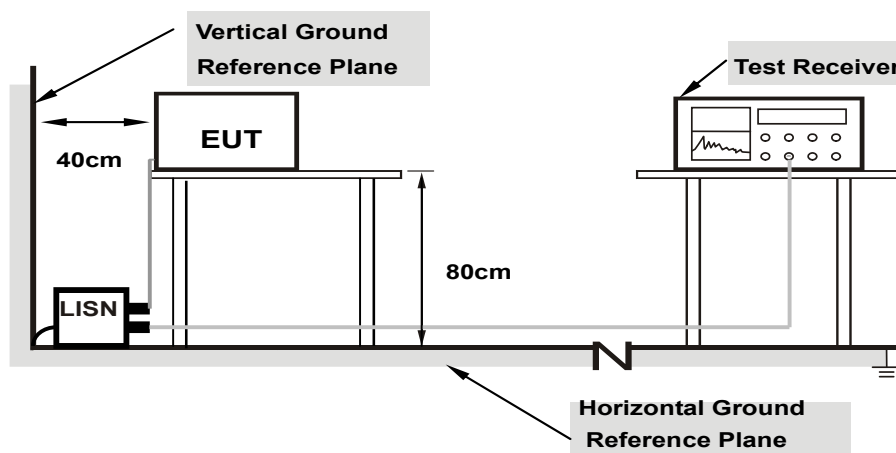

Note: 1.Support units were connected to second LISN.

For the actual test configuration, please refer to the attached file (Test Setup Photo).

4.2.5 EUT Operating Condition

Same as 4.1.6.

4.2.6 Test Results

802.11ax (HE160)

Phase	Line (L)	Detector Function	Quasi-Peak (QP) / Average (AV)
Test Mode	A		

No	Freq. [MHz]	Corr. Factor (dB)	Reading Value		Emission Level		Limit		Margin	
			[dB (uV)]		[dB (uV)]		[dB (uV)]		(dB)	
			Q.P.	AV.	Q.P.	AV.	Q.P.	AV.	Q.P.	AV.
1	0.16448	9.71	25.05	8.58	34.76	18.29	65.23	55.23	-30.47	-36.94
2	0.21406	9.71	24.22	8.06	33.93	17.77	63.05	53.05	-29.12	-35.28
3	0.37224	9.73	21.87	17.27	31.60	27.00	58.45	48.45	-26.85	-21.45
4	0.41252	9.73	24.15	15.95	33.88	25.68	57.60	47.60	-23.72	-21.92
5	0.46813	9.73	25.34	17.23	35.07	26.96	56.55	46.55	-21.48	-19.59
6	0.58563	9.74	30.05	0.94	39.79	10.68	56.00	46.00	-16.21	-35.32

Remarks:

1. Q.P. and AV. are abbreviations of quasi-peak and average individually.
2. The emission levels of other frequencies were very low against the limit.
3. Margin value = Emission level - Limit value
4. Correction factor = Insertion loss + Cable loss
5. Emission Level = Correction Factor + Reading Value.

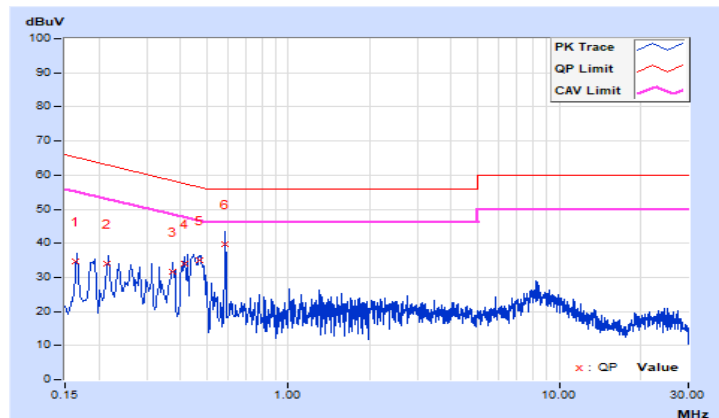

Phase	Neutral (N)	Detector Function	Quasi-Peak (QP) / Average (AV)
Test Mode	A		

No	Freq. [MHz]	Corr. Factor (dB)	Reading Value [dB (uV)]		Emission Level [dB (uV)]		Limit [dB (uV)]		Margin (dB)	
			Q.P.	AV.	Q.P.	AV.	Q.P.	AV.	Q.P.	AV.
			1	0.15000	9.76	35.04	23.37	44.80	33.13	66.00
2	0.16932	9.77	35.01	20.53	44.78	30.30	64.99	54.99	-20.21	-24.69
3	0.37421	9.79	31.26	25.36	41.05	35.15	58.41	48.41	-17.36	-13.26
4	0.41143	9.79	33.01	23.38	42.80	33.17	57.62	47.62	-14.82	-14.45
5	0.44527	9.79	34.45	23.81	44.24	33.60	56.96	46.96	-12.72	-13.36
6	0.48063	9.79	32.31	19.25	42.10	29.04	56.33	46.33	-14.23	-17.29

Remarks:

1. Q.P. and AV. are abbreviations of quasi-peak and average individually.
2. The emission levels of other frequencies were very low against the limit.
3. Margin value = Emission level - Limit value
4. Correction factor = Insertion loss + Cable loss
5. Emission Level = Correction Factor + Reading Value.

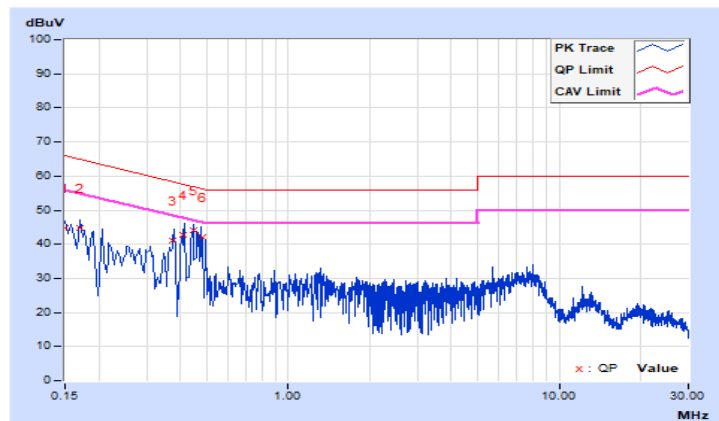

Phase	Line (L)	Detector Function	Quasi-Peak (QP) / Average (AV)
Test Mode	B		

No	Freq. [MHz]	Corr. Factor (dB)	Reading Value		Emission Level		Limit		Margin	
			[dB (uV)]		[dB (uV)]		[dB (uV)]		(dB)	
			Q.P.	AV.	Q.P.	AV.	Q.P.	AV.	Q.P.	AV.
1	0.15400	9.71	32.69	15.56	42.40	25.27	65.78	55.78	-23.38	-30.51
2	0.19000	9.71	28.27	12.13	37.98	21.84	64.04	54.04	-26.06	-32.20
3	0.22985	9.71	25.57	9.88	35.28	19.59	62.46	52.46	-27.18	-32.87
4	0.28906	9.72	23.61	9.05	33.33	18.77	60.55	50.55	-27.22	-31.78
5	0.36600	9.73	24.82	13.53	34.55	23.26	58.59	48.59	-24.04	-25.33
6	0.41799	9.73	23.28	9.91	33.01	19.64	57.49	47.49	-24.48	-27.85

Remarks:

1. Q.P. and AV. are abbreviations of quasi-peak and average individually.
2. The emission levels of other frequencies were very low against the limit.
3. Margin value = Emission level - Limit value
4. Correction factor = Insertion loss + Cable loss
5. Emission Level = Correction Factor + Reading Value.

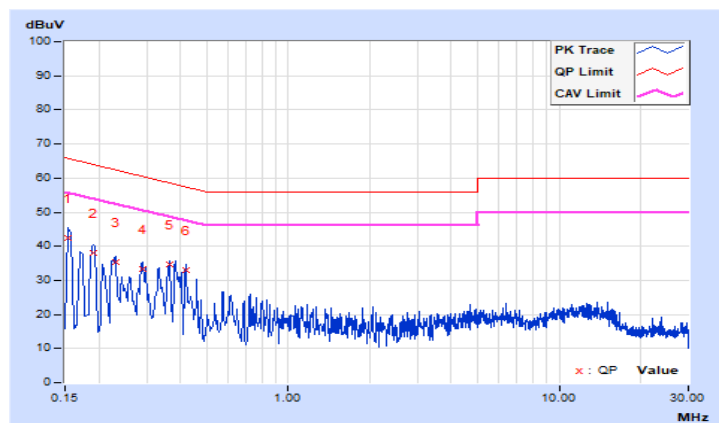

Phase	Neutral (N)	Detector Function	Quasi-Peak (QP) / Average (AV)
Test Mode	B		

No	Freq. [MHz]	Corr. Factor (dB)	Reading Value [dB (uV)]		Emission Level [dB (uV)]		Limit [dB (uV)]		Margin (dB)	
			Q.P.	AV.	Q.P.	AV.	Q.P.	AV.	Q.P.	AV.
			1	0.15400	9.77	32.40	15.84	42.17	25.61	65.78
2	0.16600	9.77	33.14	15.53	42.91	25.30	65.16	55.16	-22.25	-29.86
3	0.18200	9.77	32.10	15.52	41.87	25.29	64.39	54.39	-22.52	-29.10
4	0.31800	9.78	20.04	4.77	29.82	14.55	59.76	49.76	-29.94	-35.21
5	0.35400	9.79	22.58	16.08	32.37	25.87	58.87	48.87	-26.50	-23.00
6	0.43000	9.79	19.69	7.57	29.48	17.36	57.25	47.25	-27.77	-29.89

Remarks:

1. Q.P. and AV. are abbreviations of quasi-peak and average individually.
2. The emission levels of other frequencies were very low against the limit.
3. Margin value = Emission level - Limit value
4. Correction factor = Insertion loss + Cable loss
5. Emission Level = Correction Factor + Reading Value.

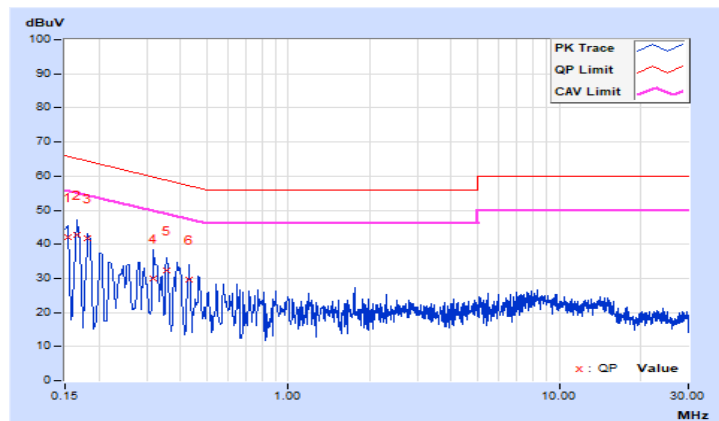

4.3 Transmit Power Measurement

4.3.1 Limits of Transmit Power Measurement

Device Category		Limit (Max Average Power)
<input checked="" type="checkbox"/>	Indoor access point	EIRP 36 dBm
<input type="checkbox"/>	Subordinate device	EIRP 36 dBm
<input type="checkbox"/>	Client device	EIRP 30 dBm

Note: For all U-NII-4 and U-NII-3 & -4 span channels shall met above EIRP values.

Per KDB 662911 Method of conducted output power measurement on IEEE 802.11 devices,

Array Gain = 0 dB (i.e., no array gain) for $N_{ANT} \leq 4$;

Array Gain = 0 dB (i.e., no array gain) for channel widths ≥ 40 MHz for any N_{ANT} ;

Array Gain = $5 \log(N_{ANT}/N_{SS})$ dB or 3 dB, whichever is less for 20-MHz channel widths with $N_{ANT} \geq 5$.

For power measurements on all other devices: Array Gain = $10 \log(N_{ANT}/N_{SS})$ dB.

4.3.2 Test Setup

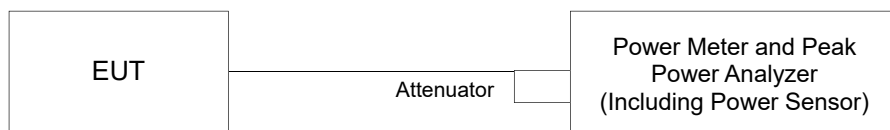

4.3.3 Test Instruments

Refer to section 4.1.2 to get information of above instrument.

4.3.4 Test Procedure

Method PM is used to perform output power measurement, trigger and gating function of wide band power meter is enabled to measure max output power of TX on burst and set the detector to average. Duty factor is not added to measured value.

4.3.5 EUT Operating Condition

The software provided by client to enable the EUT under transmission condition continuously at lowest, middle and highest channel frequencies individually.

4.3.6 Test Result

Power Output:

CDD Mode

802.11a

Chan.	Freq. (MHz)	Average Power (dBm)		Total Power (mW)	Total Power (dBm)	Maximum Gain (dBi)	EIRP (mW)	EIRP (dBm)	EIRP Limit (dBm)	Pass / Fail
		Chain 0	Chain 1							
169	5845	26.54	26.41	888.339	29.49	3.81	2137.962	33.30	36	Pass
173	5865	26.61	26.32	886.690	29.48	3.71	2084.491	33.19	36	Pass
177	5885	26.58	26.47	898.597	29.54	3.71	2113.489	33.25	36	Pass

Note: EIRP Power = conducted output power + antenna gain.

802.11ax (HE20)

Chan.	Freq. (MHz)	Average Power (dBm)		Total Power (mW)	Total Power (dBm)	Maximum Gain (dBi)	EIRP (mW)	EIRP (dBm)	EIRP Limit (dBm)	Pass / Fail
		Chain 0	Chain 1							
169	5845	26.47	26.29	869.207	29.39	3.81	2089.296	33.20	36	Pass
173	5865	26.44	26.18	855.509	29.32	3.71	2009.093	33.03	36	Pass
177	5885	26.53	26.28	874.399	29.42	3.71	2055.891	33.13	36	Pass

Note: EIRP Power = conducted output power + antenna gain.

802.11ax (HE40)

Chan.	Freq. (MHz)	Average Power (dBm)		Total Power (mW)	Total Power (dBm)	Maximum Gain (dBi)	EIRP (mW)	EIRP (dBm)	EIRP Limit (dBm)	Pass / Fail
		Chain 0	Chain 1							
167	5835	26.59	26.48	900.668	29.55	3.81	2167.704	33.36	36	Pass
175	5875	26.36	26.21	850.344	29.30	3.71	1999.862	33.01	36	Pass

Note: EIRP Power = conducted output power + antenna gain.

802.11ax (HE80)

Chan.	Freq. (MHz)	Average Power (dBm)		Total Power (mW)	Total Power (dBm)	Maximum Gain (dBi)	EIRP (mW)	EIRP (dBm)	EIRP Limit (dBm)	Pass / Fail
		Chain 0	Chain 1							
171	5855	25.31	25.25	674.591	28.29	3.81	1621.810	32.10	36	Pass

Note: EIRP Power = conducted output power + antenna gain.

802.11ax (HE160)

Chan.	Freq. (MHz)	Average Power (dBm)		Total Power (mW)	Total Power (dBm)	Maximum Gain (dBi)	EIRP (mW)	EIRP (dBm)	EIRP Limit (dBm)	Pass / Fail
		Chain 0	Chain 1							
163	5815	20.04	19.94	199.553	23.00	3.81	479.733	26.81	36	Pass

Note: EIRP Power = conducted output power + antenna gain.

Beamforming Mode

802.11ax (HE20)

Chan.	Freq. (MHz)	Average Power (dBm)		Total Power (mW)	Total Power (dBm)	Maximum Gain (dBi)	EIRP (mW)	EIRP (dBm)	EIRP Limit (dBm)	Pass / Fail
		Chain 0	Chain 1							
169	5845	25.97	25.72	768.617	28.86	6.79	3672.823	35.65	36	Pass
173	5865	26.44	26.18	855.509	29.32	6.61	3917.419	35.93	36	Pass
177	5885	26.01	25.81	780.091	28.92	6.61	3572.728	35.53	36	Pass

Notes:

1. Directional gain = $10 \log[(10^{\text{Chain0}/20} + 10^{\text{Chain1}/20})^2 / 2]$
2. For U-NII-3, Directional gain = $10 \log[(10^{G1/20} + 10^{G2/20} + \dots + 10^{GN/20})^2 / 2] = 6.79\text{dBi}$
3. For U-NII-4, Directional gain = $10 \log[(10^{G1/20} + 10^{G2/20} + \dots + 10^{GN/20})^2 / 2] = 6.61\text{dBi}$

802.11ax (HE40)

Chan.	Freq. (MHz)	Average Power (dBm)		Total Power (mW)	Total Power (dBm)	Maximum Gain (dBi)	EIRP (mW)	EIRP (dBm)	EIRP Limit (dBm)	Pass / Fail
		Chain 0	Chain 1							
167	5835	26.02	25.98	796.223	29.01	6.79	3801.894	35.80	36	Pass
175	5875	26.36	26.21	850.344	29.30	6.61	3899.420	35.91	36	Pass

Notes:

1. Directional gain = $10 \log[(10^{\text{Chain0}/20} + 10^{\text{Chain1}/20})^2 / 2]$
2. For U-NII-3, Directional gain = $10 \log[(10^{G1/20} + 10^{G2/20} + \dots + 10^{GN/20})^2 / 2] = 6.79\text{dBi}$
3. For U-NII-4, Directional gain = $10 \log[(10^{G1/20} + 10^{G2/20} + \dots + 10^{GN/20})^2 / 2] = 6.61\text{dBi}$

802.11ax (HE80)

Chan.	Freq. (MHz)	Average Power (dBm)		Total Power (mW)	Total Power (dBm)	Maximum Gain (dBi)	EIRP (mW)	EIRP (dBm)	EIRP Limit (dBm)	Pass / Fail
		Chain 0	Chain 1							
171	5855	25.31	25.25	674.591	28.29	6.79	3221.069	35.08	36	Pass

Notes:

1. Directional gain = $10 \log[(10^{\text{Chain0}/20} + 10^{\text{Chain1}/20})^2 / 2]$
2. For U-NII-3, Directional gain = $10 \log[(10^{G1/20} + 10^{G2/20} + \dots + 10^{GN/20})^2 / 2] = 6.79\text{dBi}$

802.11ax (HE160)

Chan.	Freq. (MHz)	Average Power (dBm)		Total Power (mW)	Total Power (dBm)	Maximum Gain (dBi)	EIRP (mW)	EIRP (dBm)	EIRP Limit (dBm)	Pass / Fail
		Chain 0	Chain 1							
163	5815	20.04	19.94	199.553	23.00	6.79	952.796	29.79	36	Pass

Notes:

1. Directional gain = $10 \log[(10^{\text{Chain0}/20} + 10^{\text{Chain1}/20})^2 / 2]$
2. For U-NII-3, Directional gain = $10 \log[(10^{G1/20} + 10^{G2/20} + \dots + 10^{GN/20})^2 / 2] = 6.79\text{dBi}$

4.4 6dB Bandwidth Measurement

4.4.1 Limits of Emission Bandwidth Measurement

Within the 5.725-5.850GHz and 5.850-5.895 GHz bands, the minimum 6 dB bandwidth of U-NII devices shall be at least 500 kHz.

4.4.2 Test Setup

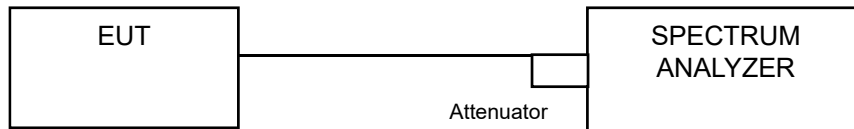

4.4.3 Test Instruments

Refer to section 4.1.2 to get information of above instrument.

4.4.4 Test Procedure

- a. Set resolution bandwidth (RBW) = 100kHz
- b. Set the video bandwidth (VBW) $\geq 3 \times$ RBW, Detector = Peak.
- c. Trace mode = max hold.
- d. Sweep = auto couple.
- e. Measure the maximum width of the emission that is constrained by the frequencies associated with the two amplitude points (upper and lower) that are attenuated by 6 dB relative to the maximum level measured in the fundamental emission

4.4.5 Test Results

802.11a

Channel	Frequency (MHz)	6dB Bandwidth (MHz)		Minimum Limit (MHz)	Pass / Fail
		Chain 0	Chain 1		
169	5845	15.14	15.08	0.5	Pass
173	5865	15.14	15.13	0.5	Pass
177	5885	15.15	15.11	0.5	Pass

802.11ax (HE20)

Channel	Frequency (MHz)	6dB Bandwidth (MHz)		Minimum Limit (MHz)	Pass / Fail
		Chain 0	Chain 1		
169	5845	13.87	15.15	0.5	Pass
173	5865	14.27	13.92	0.5	Pass
177	5885	15.12	14.95	0.5	Pass

802.11ax (HE40)

Channel	Frequency (MHz)	6dB Bandwidth (MHz)		Minimum Limit (MHz)	Pass / Fail
		Chain 0	Chain 1		
167	5835	33.89	34.21	0.5	Pass
175	5875	35.10	32.60	0.5	Pass

802.11ax (HE80)

Channel	Frequency (MHz)	6dB Bandwidth (MHz)		Minimum Limit (MHz)	Pass / Fail
		Chain 0	Chain 1		
171	5855	59.06	63.89	0.5	Pass

802.11ax (HE160)

Channel	Frequency (MHz)	6dB Bandwidth (MHz)		Minimum Limit (MHz)	Pass / Fail
		Chain 0	Chain 1		
163	5815	131.11	119.47	0.5	Pass

Spectrum Plot of Worst Value

802.11a

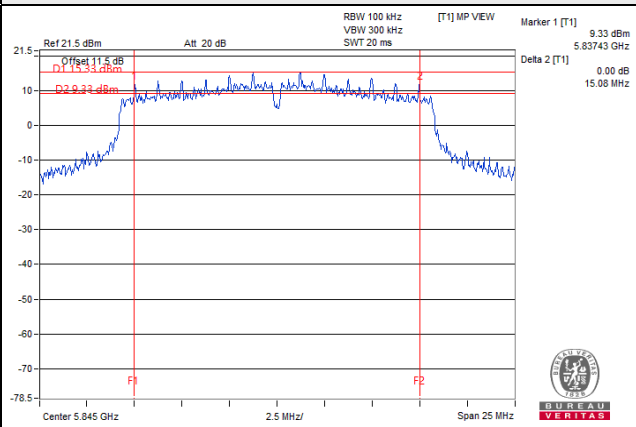

802.11ax (HE20)

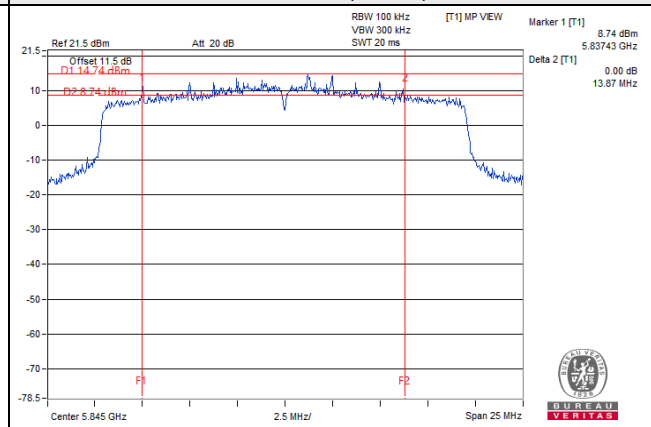

802.11ax (HE40)

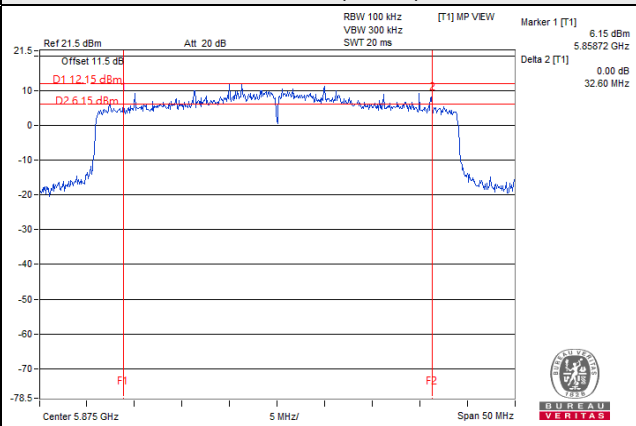

802.11ax (HE80)

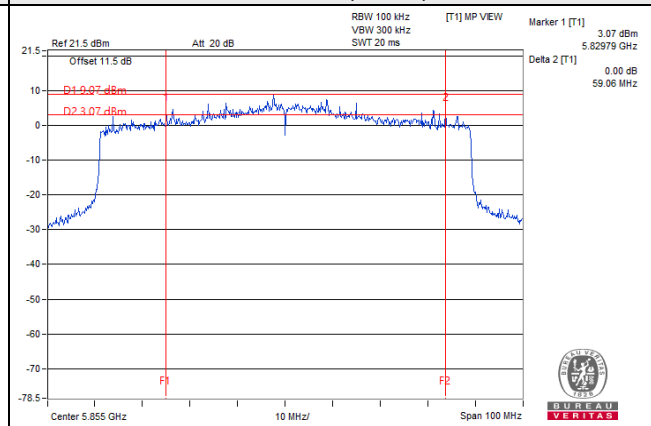

802.11ax (HE160)

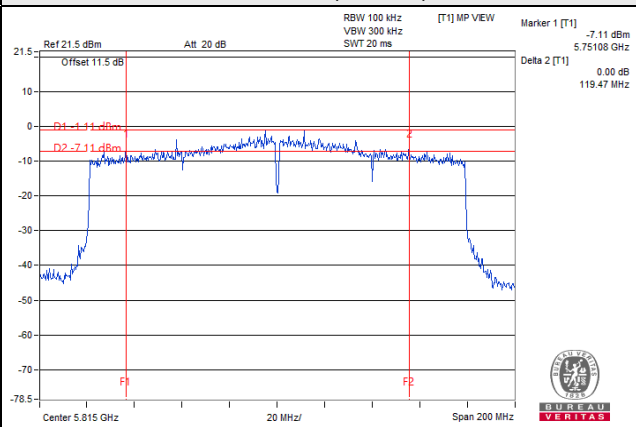

4.5 Peak Power Spectral Density Measurement

4.5.1 Limits of Peak Power Spectral Density Measurement

Device Category		Limit
<input checked="" type="checkbox"/>	Indoor access point	EIRP 20 dBm/MHz
<input type="checkbox"/>	Subordinate device	EIRP 20 dBm/MHz
<input type="checkbox"/>	Client device	EIRP 14 dBm/MHz

Note: For all U-NII-4 and U-NII-3 & -4 span channels shall met above EIRP values.

4.5.2 Test Setup

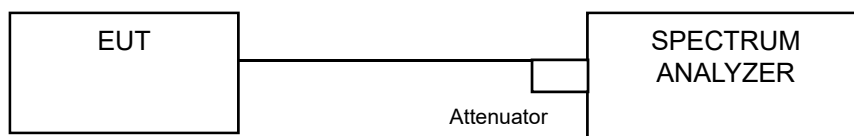

4.5.3 Test Instruments

Refer to section 4.1.2 to get information of above instrument.

4.5.4 Test Procedure

Using method SA-2

- a. Set span to encompass the entire emission bandwidth (EBW) of the signal.
- b. Set RBW = 300 kHz, Set VBW \geq 1 MHz, Detector = RMS
- c. Sweep time = auto, trigger set to "free run".
- d. Trace average at least 100 traces in power averaging mode.
- e. Use the peak search function on the instrument to find the peak of the spectrum and record its value.
- f. Scale the observed power level to an equivalent value in 1 MHz by adjusting (reducing) the measured power by a bandwidth correction factor (BWCF) where $BWCF = 10 \log(1000 \text{ kHz}/300 \text{ kHz}) = 5.23 \text{ dB}$
- g. Record the max value and add $10 \log(1/\text{duty cycle})$.

4.5.5 EUT Operating Condition

Same as Item 4.3.6.

4.5.6 Test Results

802.11a

Chan.	Chan. Freq. (MHz)	PSD w/o Duty Factor (dBm/MHz)		Total PSD w/o Duty Factor (dBm/300 kHz)	Duty Factor (dB)	Total PSD (dBm/MHz)	Directional Gain (dBi)	EIRP PSD (dBm/MHz)	EIRP PSD Limit (dBm/MHz)	Pass / Fail
		Chain 0	Chain 1							
169	5845	3.48	3.68	6.59	0.24	12.06	6.79	18.85	20	Pass
173	5865	3.12	3.16	6.15	0.24	11.62	6.61	18.23	20	Pass
177	5885	3.26	3.07	6.18	0.24	11.65	6.61	18.26	20	Pass

- Note: 1. Method a) of power density measurement of KDB 662911 is using for calculating total power density. Total power density is summing entire spectra across corresponding frequency bins on the various outputs by computer.
2. For U-NII-3, Directional gain = $10 \log[(10^{G1/20} + 10^{G2/20} + \dots + 10^{GN/20})^2/2] = 6.79\text{dBi}$
3. For U-NII-4, Directional gain = $10 \log[(10^{G1/20} + 10^{G2/20} + \dots + 10^{GN/20})^2/2] = 6.61\text{dBi}$
4. Refer to section 3.3 for duty cycle spectrum plot.

802.11ax (HE20)

Chan.	Chan. Freq. (MHz)	PSD w/o Duty Factor (dBm/MHz)		Total PSD w/o Duty Factor (dBm/300 kHz)	Duty Factor (dB)	Total PSD (dBm/MHz)	Directional Gain (dBi)	EIRP PSD (dBm/MHz)	EIRP PSD Limit (dBm/MHz)	Pass / Fail
		Chain 0	Chain 1							
169	5845	1.34	2.05	4.72	0.36	10.31	6.79	17.10	20	Pass
173	5865	1.93	0.99	4.50	0.36	10.09	6.61	16.70	20	Pass
177	5885	1.13	0.68	3.92	0.36	9.51	6.61	16.12	20	Pass

- Note: 1. Method a) of power density measurement of KDB 662911 is using for calculating total power density. Total power density is summing entire spectra across corresponding frequency bins on the various outputs by computer.
2. For U-NII-3, Directional gain = $10 \log[(10^{G1/20} + 10^{G2/20} + \dots + 10^{GN/20})^2/2] = 6.79\text{dBi}$
3. For U-NII-4, Directional gain = $10 \log[(10^{G1/20} + 10^{G2/20} + \dots + 10^{GN/20})^2/2] = 6.61\text{dBi}$
4. Refer to section 3.3 for duty cycle spectrum plot.

802.11ax (HE40)

Chan.	Chan. Freq. (MHz)	PSD w/o Duty Factor (dBm/MHz)		Total PSD w/o Duty Factor (dBm/300 kHz)	Duty Factor (dB)	Total PSD (dBm/MHz)	Directional Gain (dBi)	EIRP PSD (dBm/MHz)	EIRP PSD Limit (dBm/MHz)	Pass / Fail
		Chain 0	Chain 1							
167	5835	-1.51	-0.59	1.98	0.42	7.63	6.79	14.42	20	Pass
175	5875	-1.70	-1.50	1.41	0.42	7.06	6.61	13.67	20	Pass

- Note: 1. Method a) of power density measurement of KDB 662911 is using for calculating total power density. Total power density is summing entire spectra across corresponding frequency bins on the various outputs by computer.
2. For U-NII-3, Directional gain = $10 \log[(10^{G1/20} + 10^{G2/20} + \dots + 10^{GN/20})^2/2] = 6.79\text{dBi}$
3. For U-NII-4, Directional gain = $10 \log[(10^{G1/20} + 10^{G2/20} + \dots + 10^{GN/20})^2/2] = 6.61\text{dBi}$
4. Refer to section 3.3 for duty cycle spectrum plot.

802.11ax (HE80)

Chan.	Chan. Freq. (MHz)	PSD w/o Duty Factor (dBm/MHz)		Total PSD w/o Duty Factor (dBm/300 kHz)	Duty Factor (dB)	Total PSD (dBm/MHz)	Directional Gain (dBi)	EIRP PSD (dBm/MHz)	EIRP PSD Limit (dBm/MHz)	Pass / Fail
		Chain 0	Chain 1							
171	5855	-3.26	-4.81	-0.96	0.41	4.68	6.79	11.47	20	Pass

Note: 1. Method a) of power density measurement of KDB 662911 is using for calculating total power density. Total power density is summing entire spectra across corresponding frequency bins on the various outputs by computer.

2. For U-NII-3, Directional gain = $10 \log[(10^{G1/20} + 10^{G2/20} + \dots + 10^{GN/20})^2/2] = 6.79\text{dBi}$

3. Refer to section 3.3 for duty cycle spectrum plot.

802.11ax (HE160)

Chan.	Chan. Freq. (MHz)	PSD w/o Duty Factor (dBm/MHz)		Total PSD w/o Duty Factor (dBm/300 kHz)	Duty Factor (dB)	Total PSD (dBm/MHz)	Directional Gain (dBi)	EIRP PSD (dBm/MHz)	EIRP PSD Limit (dBm/MHz)	Pass / Fail
		Chain 0	Chain 1							
163	5815	-15.42	-14.67	-12.02	0.48	-6.31	6.79	0.48	20	Pass

Note: 1. Method a) of power density measurement of KDB 662911 is using for calculating total power density. Total power density is summing entire spectra across corresponding frequency bins on the various outputs by computer.

2. For U-NII-3, Directional gain = $10 \log[(10^{G1/20} + 10^{G2/20} + \dots + 10^{GN/20})^2/2] = 6.79\text{dBi}$

3. Refer to section 3.3 for duty cycle spectrum plot.

Spectrum Plot of Worst Value

802.11a

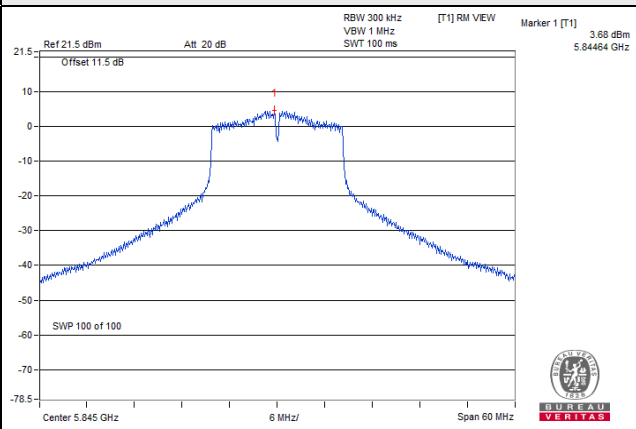

802.11ax (HE20)

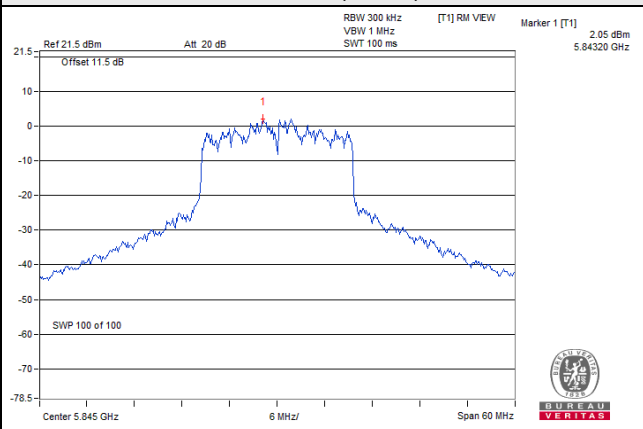

802.11ax (HE40)

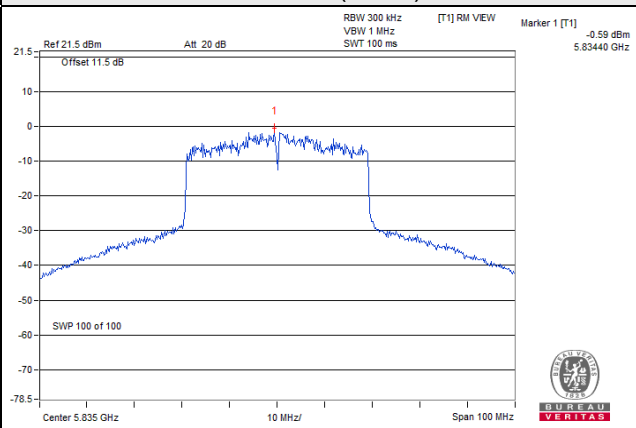

802.11ax (HE80)

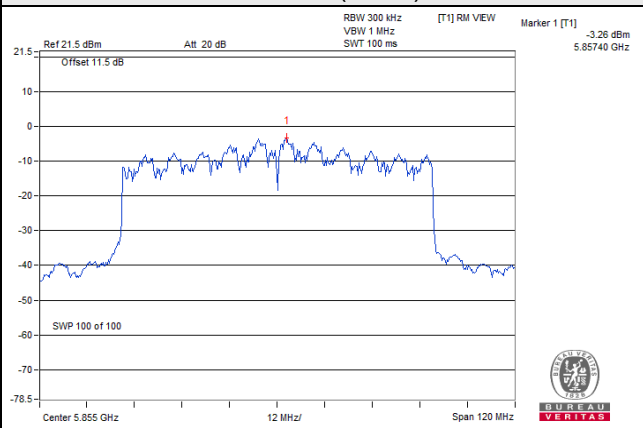

802.11ax (HE160)

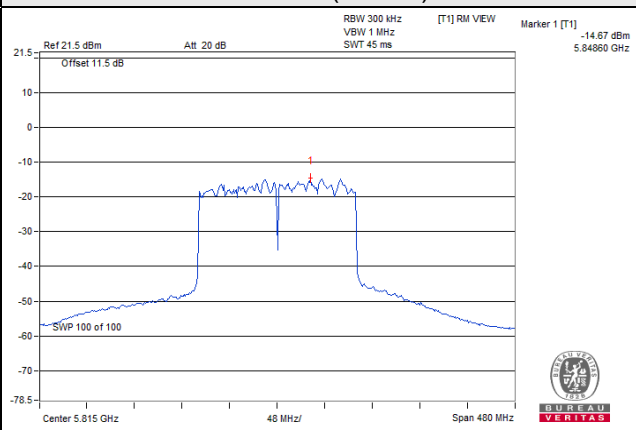

4.6 Frequency Stability Measurement

4.6.1 Limits of Frequency Stability Measurement

The frequency of the carrier signal shall be maintained within band of operation

4.6.2 Test Setup

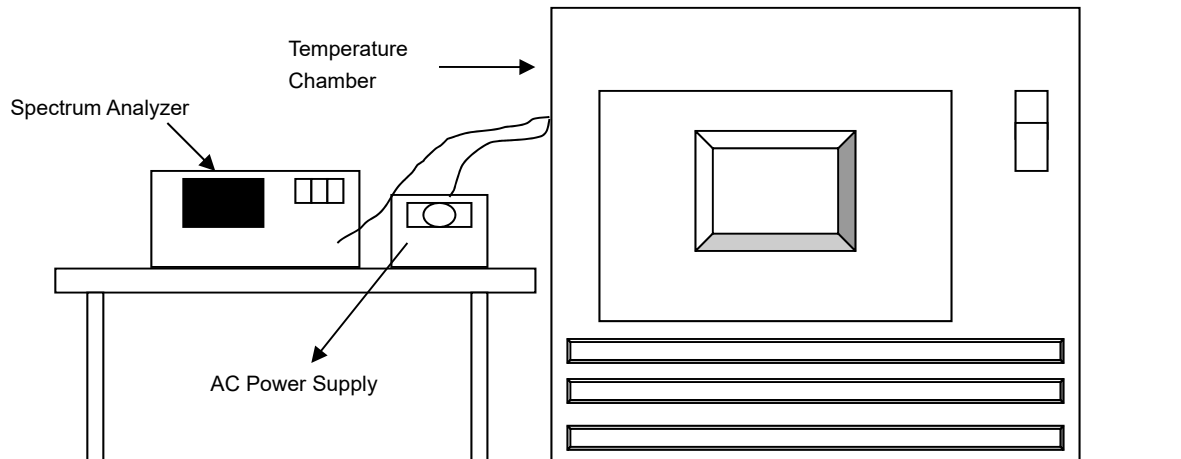

4.6.3 Test Instruments

Refer to section 4.1.2 to get information of above instrument.

4.6.4 Test Procedure

- The EUT was placed inside the environmental test chamber and powered by nominal AC voltage.
- Turn the EUT on and couple its output to a spectrum analyzer.
- Turn the EUT off and set the chamber to the highest temperature specified.
- Allow sufficient time (approximately 30 min) for the temperature of the chamber to stabilize, turn the EUT on and measure the operating frequency after 2, 5, and 10 Minutes.
- Repeat step (d) with the temperature chamber set to the next desired temperature until measurements down to the lowest specified temperature have been completed..
- The test chamber was allowed to stabilize at +20 degree C for a minimum of 30 Minutes. The supply voltage was then adjusted on the EUT from 85% to 115% and the frequency record.

4.6.5 EUT Operating Condition

Set the EUT transmit at un-modulation mode to test frequency stability.

4.6.6 Test Results

802.11a

Frequency Stability Versus Temp.									
Operating Frequency: 5885MHz									
TEMP. (°C)	Power Supply (Vac)	0 Minute		2 Minute		5 Minute		10 Minute	
		Measured Frequency (MHz)	Pass/Fail	Measured Frequency (MHz)	Pass/Fail	Measured Frequency (MHz)	Pass/Fail	Measured Frequency (MHz)	Pass/Fail
40	120	5884.9873	Pass	5884.9830	Pass	5884.9883	Pass	5884.9870	Pass
30	120	5885.0198	Pass	5885.0186	Pass	5885.0201	Pass	5885.0212	Pass
20	120	5885.0126	Pass	5885.0143	Pass	5885.0101	Pass	5885.0093	Pass
10	120	5885.0116	Pass	5885.0085	Pass	5885.0111	Pass	5885.0088	Pass
0	120	5884.9822	Pass	5884.9828	Pass	5884.9826	Pass	5884.9824	Pass

Frequency Stability Versus Voltage									
Operating Frequency: 5885MHz									
TEMP. (°C)	Power Supply (Vac)	0 Minute		2 Minute		5 Minute		10 Minute	
		Measured Frequency (MHz)	Pass/Fail	Measured Frequency (MHz)	Pass/Fail	Measured Frequency (MHz)	Pass/Fail	Measured Frequency (MHz)	Pass/Fail
20	138	5885.0113	Pass	5885.0130	Pass	5885.0143	Pass	5885.0147	Pass
	120	5885.0126	Pass	5885.0143	Pass	5885.0101	Pass	5885.0093	Pass
	102	5885.0195	Pass	5885.0172	Pass	5885.0156	Pass	5885.0175	Pass

4.7 Operational Restrictions for U-NII 4 Devices

4.7.1 Limits of Operational Restrictions for U-NII 4 Devices

(1) Indoor Access Point.

An access point that operates in the 5.850-5.895 GHz, is supplied power from a wired connection, has an integrated antenna, is not battery powered, and does not have a weatherized enclosure. Indoor access point devices must bear the following statement in a conspicuous location on the device and in the user's manual: FCC regulations restrict operation of this device to indoor use only.

(2) Subordinate Device.

A subordinate device that operates in the 5.850-5.895 GHz band under the control of an Indoor Access Point, is supplied power from a wired connection, has an integrated antenna, is not battery powered, does not have a weatherized enclosure, and does not have a direct connection to the internet. Subordinate devices must not be used to connect devices between separate buildings or structures. Subordinate devices must be authorized under certification procedures in part 2 of this chapter. Modules may not be certified as subordinate devices.

(3) Client Device.

A client device whose transmissions are generally under the control of an access point and is not capable of initiating a network

4.7.2 Test Setup

N/A

4.7.3 Test Instruments

N/A

4.7.4 Test Procedure

N/A.

4.7.5 Test Results

Device is an Indoor Access Point, all restrictions are meet the §15.403 requirements. Please refer to the Attestation letter exhibit supplied within this application.

5 Pictures of Test Arrangements

Please refer to the attached file (Test Setup Photo).

Annex A – Band Edge Measurement

802.11a

Channel 169

Horizontal (Peak)

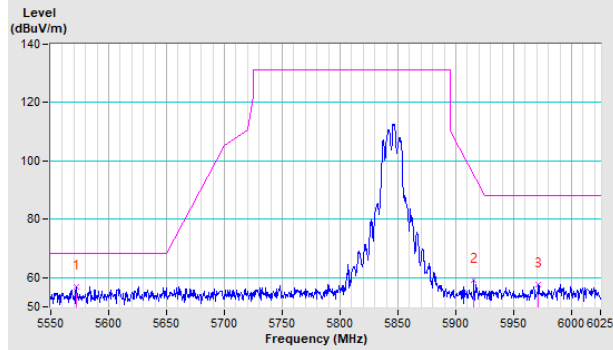

Vertical (Peak)

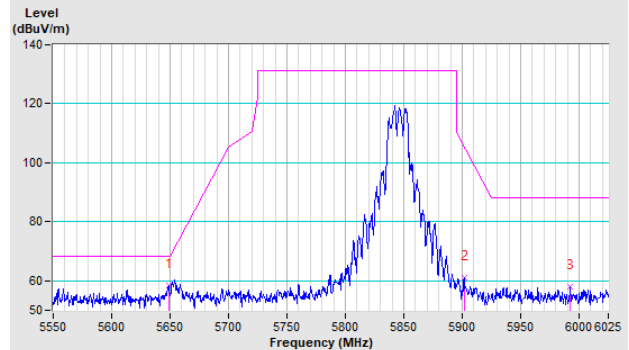

Channel 173

Horizontal (Peak)

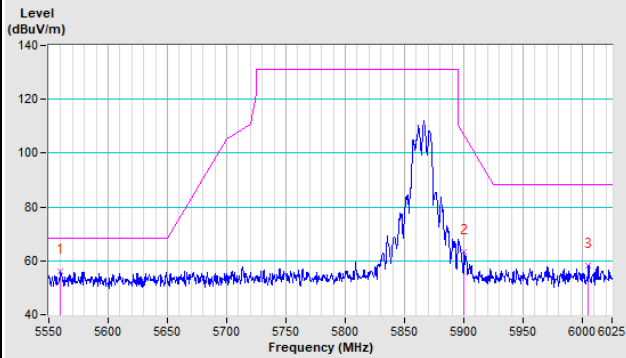

Vertical (Peak)

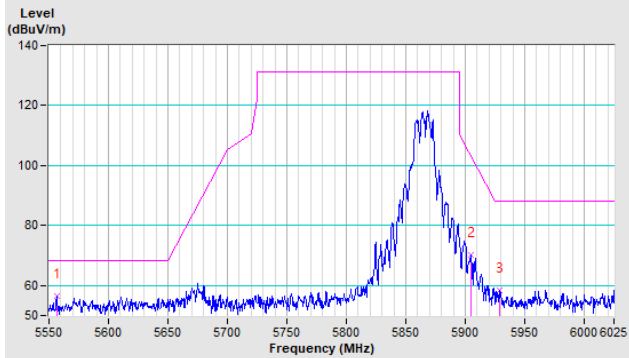

Channel 177

Horizontal (Peak)

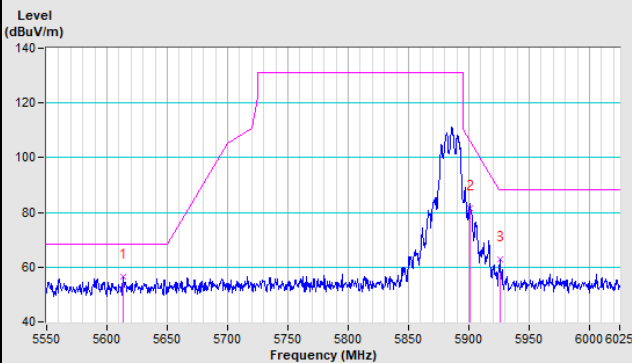

Vertical (Peak)

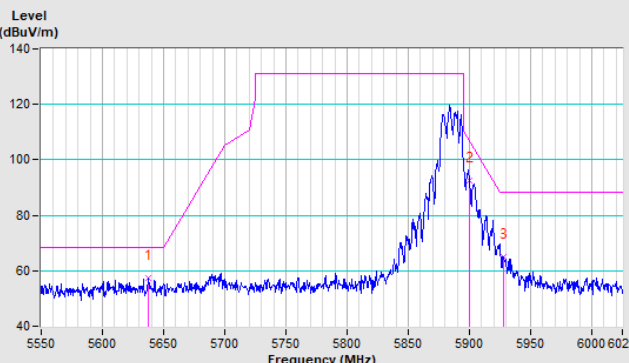

802.11ax (HE20)

Channel 169

Horizontal (Peak)

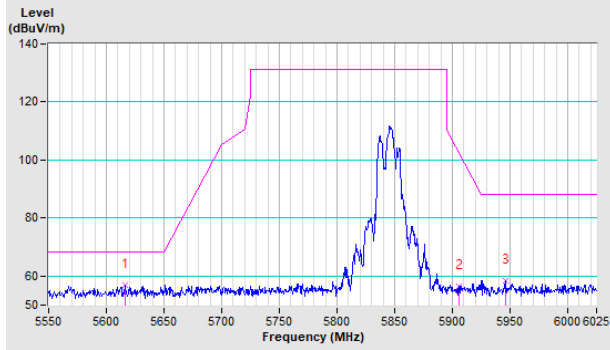

Vertical (Peak)

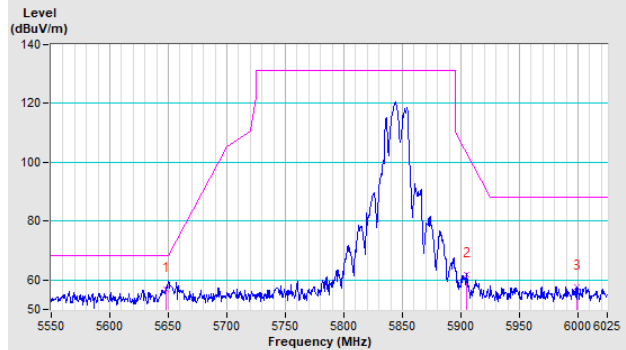

Channel 173

Horizontal (Peak)

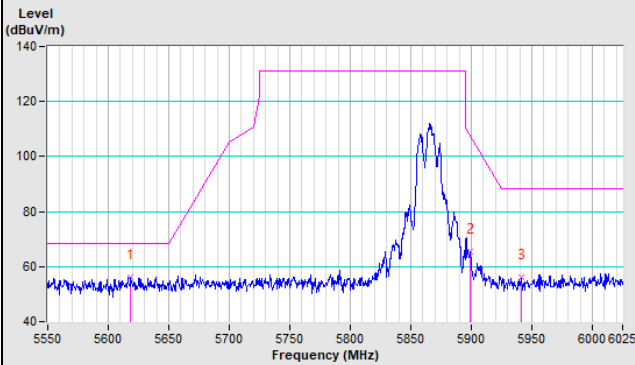

Vertical (Peak)

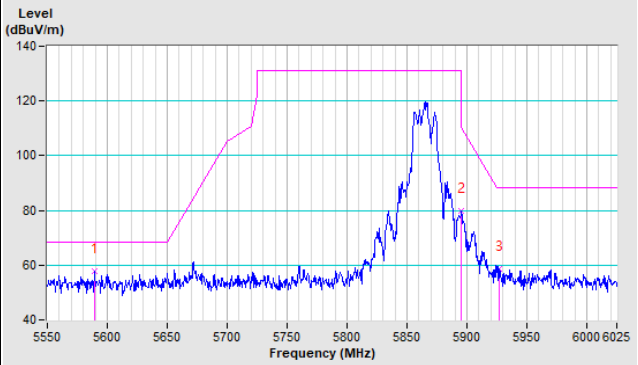

Channel 177

Horizontal (Peak)

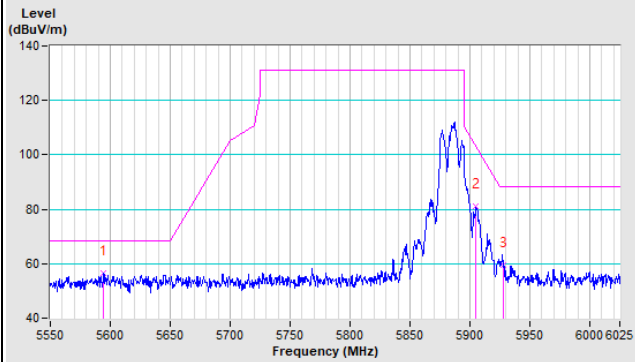

Vertical (Peak)

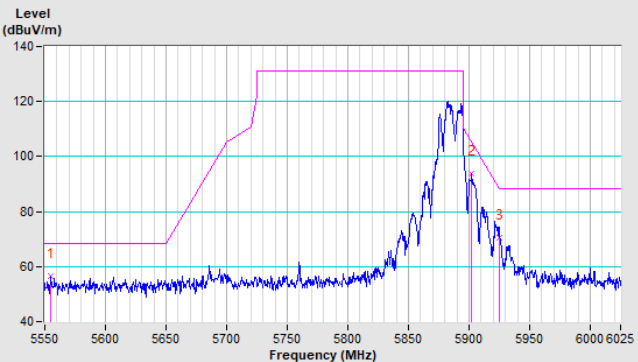

802.11ax (HE40)

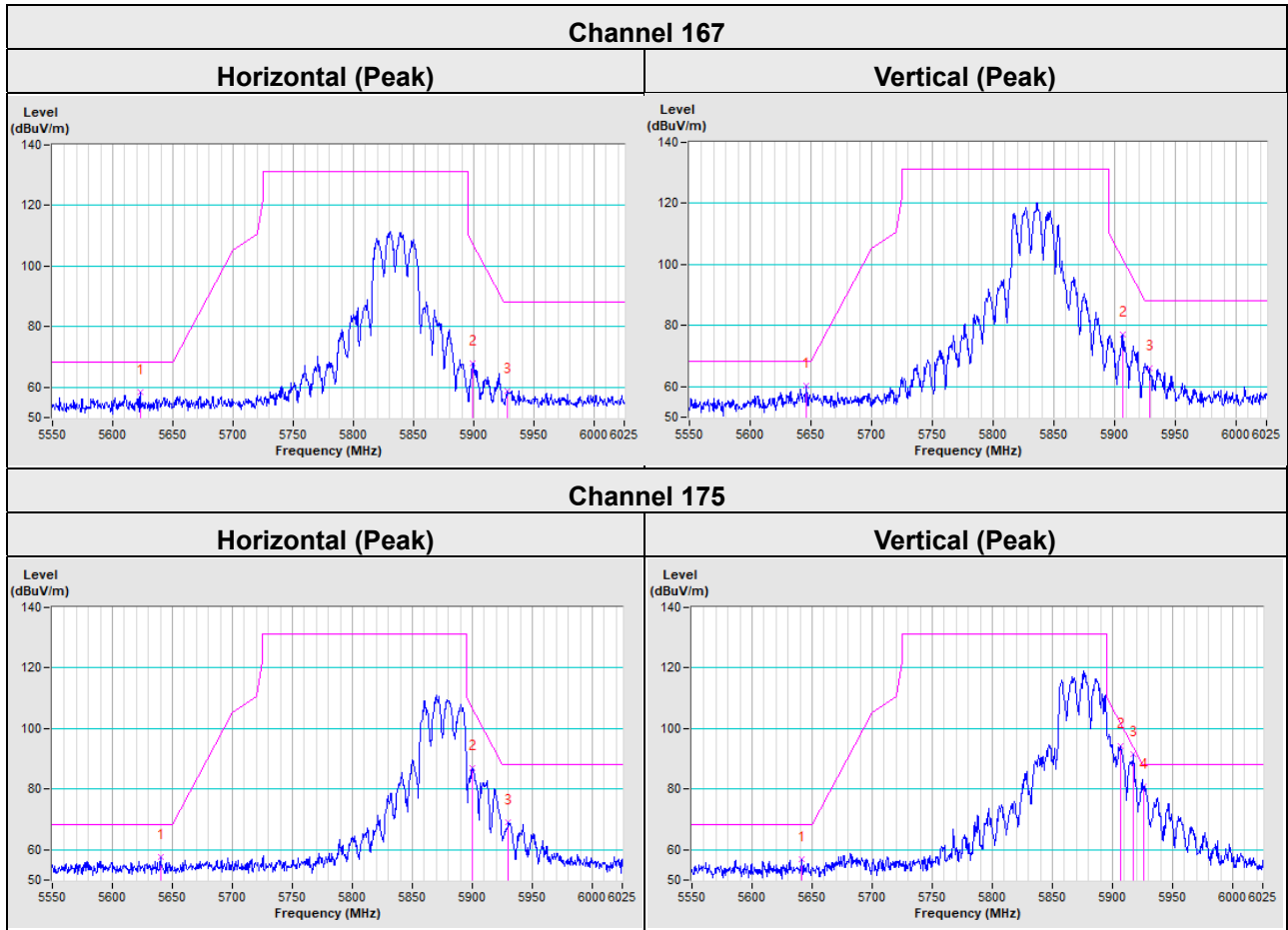

802.11ax (HE80)

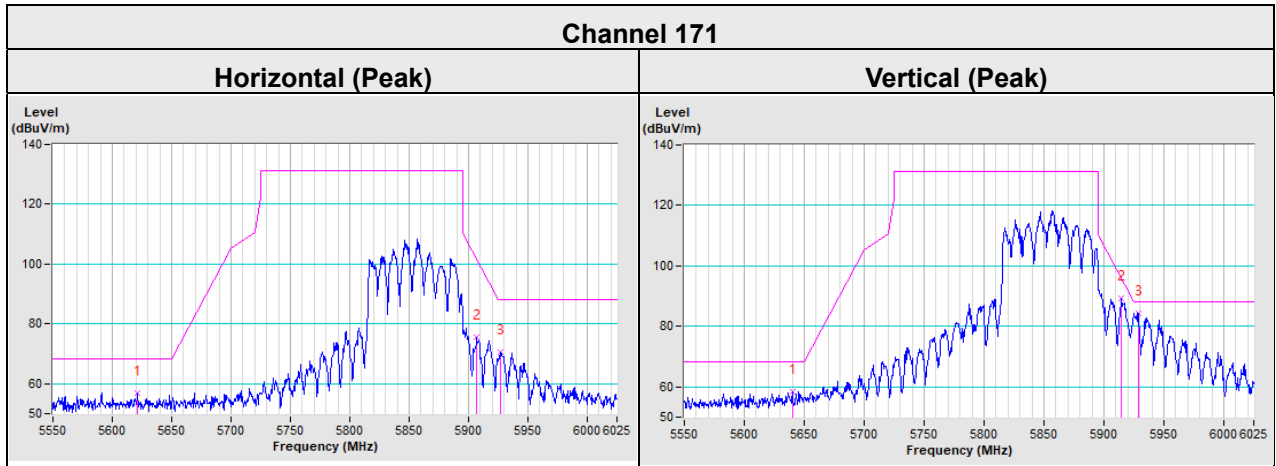

802.11ax (HE160)

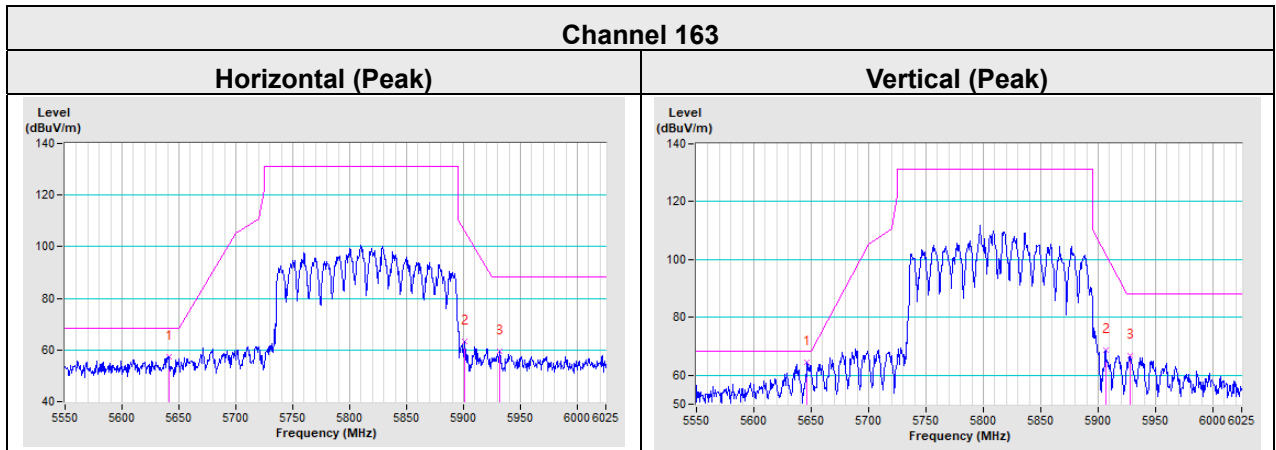

Appendix – Information of the Testing Laboratories

We, Bureau Veritas Consumer Products Services (H.K.) Ltd., Taoyuan Branch, were founded in 1988 to provide our best service in EMC, Radio, Telecom and Safety consultation. Our laboratories are FCC recognized accredited test firms and accredited according to ISO/IEC 17025.

If you have any comments, please feel free to contact us at the following:

Lin Kou EMC/RF Lab

Tel: 886-2-26052180

Fax: 886-2-26051924

Hsin Chu EMC/RF/Telecom Lab

Tel: 886-3-6668565

Fax: 886-3-6668323

Hwa Ya EMC/RF/Safety Lab

Tel: 886-3-3183232

Fax: 886-3-3270892

Email: service.adt@tw.bureauveritas.com

Web Site: www.bureauveritas-adt.com

The address and road map of all our labs can be found in our web site also.

--- END ---