

规格：82\*40MM  
材质：PC 0.125厚  
表面：三色印刷（3M胶）

国际

国内

规格：81\*40MM  
材质：PC 0.125厚  
表面：三色印刷（3M胶）

CE KS5

**YADEA** Manufacturer: Yadea Technology Group co., Ltd  
Dongsheng Road, Dacheng Industrial Zone,  
Anzhen, Xishan District, Wuxi, Jiangsu, China

Product name: Electric scooter Model number: KS5  
Motor power: 350 W Max speed: 25 km/h  
Battery capacity: 36 VDC10.4 Ah Input voltage: 42 VDC, 2 A  
Net weight: 40.92 lbs (18.6 Kg) Max rider weight: 242 lbs (110 Kg)  
Execution standard: prEN17128 Vehicle level: PLEV2 level  
Manufacturing: 2nd, 2021

IPX4 BC III CE SGS

CE KS5pro

**YADEA** Manufacturer: Yadea Technology Group co., Ltd  
Dongsheng Road, Dacheng Industrial Zone,  
Anzhen, Xishan District, Wuxi, Jiangsu, China

Product name: Electric scooter Model number: KS5pro  
Motor power: 500 W Max speed: 25 km/h  
Battery capacity: 36 VDC15.6 Ah Input voltage: 42 VDC, 2 A  
Net weight: 45.76 lbs (20.8 Kg) Max rider weight: 242 lbs (110 Kg)  
Execution standard: prEN17128 Vehicle level: PLEV2 level  
Manufacturing: 2nd, 2021

IPX4 BC III CE SGS

UL KS5 料号：B056ZL90880511

**YADEA** Manufacturer: Yadea Technology Group co., Ltd  
Dongsheng Road, Dacheng Industrial Zone,  
Anzhen, Xishan District, Wuxi, Jiangsu, China

Product name: Electric scooter Model number: KS5  
Motor power: 350 W Max speed: 30 km/h  
Battery capacity: 36 VDC10.4 Ah Input voltage: 42 VDC, 2 A  
Net weight: 40.92 lbs (18.6 Kg) Max rider weight: 242 lbs (110 Kg)  
Manufacturing: 2nd, 2021 Execution standards: UL2272

IPX4 BC III CE SGS

UL KS5pro

**YADEA** Manufacturer: Yadea Technology Group co., Ltd  
Dongsheng Road, Dacheng Industrial Zone,  
Anzhen, Xishan District, Wuxi, Jiangsu, China

Product name: Electric scooter Model number: KS5pro  
Motor power: 500 W Max speed: 35 km/h  
Battery capacity: 36 VDC15.6 Ah Input voltage: 42 VDC, 2 A  
Net weight: 45.76 lbs (20.8 Kg) Max rider weight: 242 lbs (110 Kg)  
Manufacturing: 2nd, 2021 Execution standards: UL2272

IPX4 BC III CE SGS

料号：B056ZL96880511

FCC标贴  
规格：60\*40MM  
材质：PC 0.125厚  
表面：两色印刷（皇冠513背胶）

FCC ID: 2AYR9YWTT01

This device complies with part 15 of the FCC Rules.  
Operation is subject to the following two conditions:  
(1) This device may not cause harmful interference, and  
(2) this device must accept any interference received,  
including interference that may cause undesired  
operation.

料号：B056ZL93880510

充电警示标贴  
规格：60\*40MM  
材质：PC 0.125厚  
表面：三色印刷（3M胶）

**Warning!**

1. Please use the specified in the original charger, shut off The power switch before charging.
2. When charging, first open the charging hole cover, insert The plug of the charger output to recharge the hole, and Then insert the plug of the charger input power socket.
3. The charger indicator lights in red, said the battery is Charging; When the indicator light To green, said the Battery is complete.
4. Complete charging back cover tight protection cover.
5. Warning: be careful to get an electric shock, strictly forbid Disassembling.

料号：B056ZL92880511

整车警示标贴  
规格：70\*67MM  
材质：PC 0.125厚  
表面：三色印刷（3M胶）

**Warning!**

1. WARNING - To reduce the risk of injury, user must read instruction manual. (AVERTISSEMENT - Pour prévenir les blessures, l'utilisateur doit lire le manuel d'utilisation)
2. This product is not suitable for children, only for the use of an adult.
3. When using wear helmets and, shoes other protective equipment.
4. In an open place (not in the driveway) practice, familiar with after operation Using this product.
5. Avoid bad weather such as snow and rain winds fog using this product
6. Avoid using this product in the night.
7. Never use near motor vehicles or bodies of water.
8. Do not use this product in oily or icy roads.
9. According to local regulations require the use of this product.
10. If there is damage to stop using this product.
11. Store Indoors When Not in use.
12. Use only charger as specified in user manual

料号：B056ZL91880511

制动盘及电机安全警示贴  
规格：30\*10MM  
材质：PC 0.125厚  
表面：三色印刷（3M胶）

**Warning: the motor surface overheating**

电机料号：B056ZL94880511

**Warning: brake disc surface overheating**

制动盘料号：B056ZL95880511

国标 H3pro 料号：B056ZL97880511

**YADEA** 产品名称：电动滑板车 型号：H3pro 制造商：雅迪科技集团有限公司  
电机功率：500W 最高车速：35km/h 地址：江苏省无锡市锡山安镇东  
电池容量：36VDC15.6Ah 输入电压：42VDC,2A 盛路大成工业园  
整车质量：20.8 Kg 最大载重：110 Kg 中国制造  
制造年月：2021年 2月  
执行标准：参考 UL2272/prEN17128

IPX4 BC III CE SGS

国标 H3 料号：B056ZM03880511

**YADEA** 产品名称：电动滑板车 型号：H3 制造商：雅迪科技集团有限公司  
电机功率：350W 最高车速：30km/h 地址：江苏省无锡市锡山安镇东  
电池容量：36VDC10.4Ah 输入电压：42VDC,2A 盛路大成工业园  
整车质量：18.6 Kg 最大载重：110 Kg 中国制造  
制造年月：2021年 2月  
执行标准：参考 UL2272/prEN17128

IPX4 BC III CE SGS

**警告!**

1. 为避免受伤，使用前应仔细阅读用户手册，并按照用户手册操作使用。
2. 本产品不适合儿童，仅供一名成年人使用。
3. 使用时佩戴头盔，鞋子及其他防护用品。
4. 在空旷的地方(不能在车道上)练习，熟悉操作后使用本产品。
5. 避免在雨雪大风大雾等恶劣天气使用本产品
6. 避免在夜间使用本产品。
7. 切勿在机动车辆和水源附近使用本产品。
8. 切勿在油性或结冰的路面使用本产品。
9. 应根据当地法规要求使用本产品。
10. 如有损坏时停止使用本产品。
11. 不使用时存放在室内。
12. 只使用用户手册中规定的充电器。

整车警示标贴

规格：70\*90MM  
材质：PC 0.125厚  
表面：三色印刷（3M胶）  
料号：B056ZL98880511

**警告!**

1. 请使用指定的原装充电器充电，充电前关闭电源开关。
2. 充电时，先打开充电孔盖，将充电器输出插头插入充电孔，再将充电器输入插头插入电源插座。
3. 充电器指示灯为红色时，表示电池正在充电；当指示灯变为绿色时，表示电池充电完成。
4. 充电完成后盖紧保护盖。
5. 警告：小心触电，严禁擅自拆装。

充电警示标贴

规格：60\*40MM  
材质：PC 0.125厚  
表面：三色印刷（3M胶）  
料号：B056ZL99880511

**警告：电机表面过热**

**警告：制动盘表面过热**

制动盘及电机安全警示贴

规格：30\*10MM  
材质：PC 0.125厚  
表面：三色印刷（3M胶）

料号：B056ZM01880511 料号：B056ZM02880511

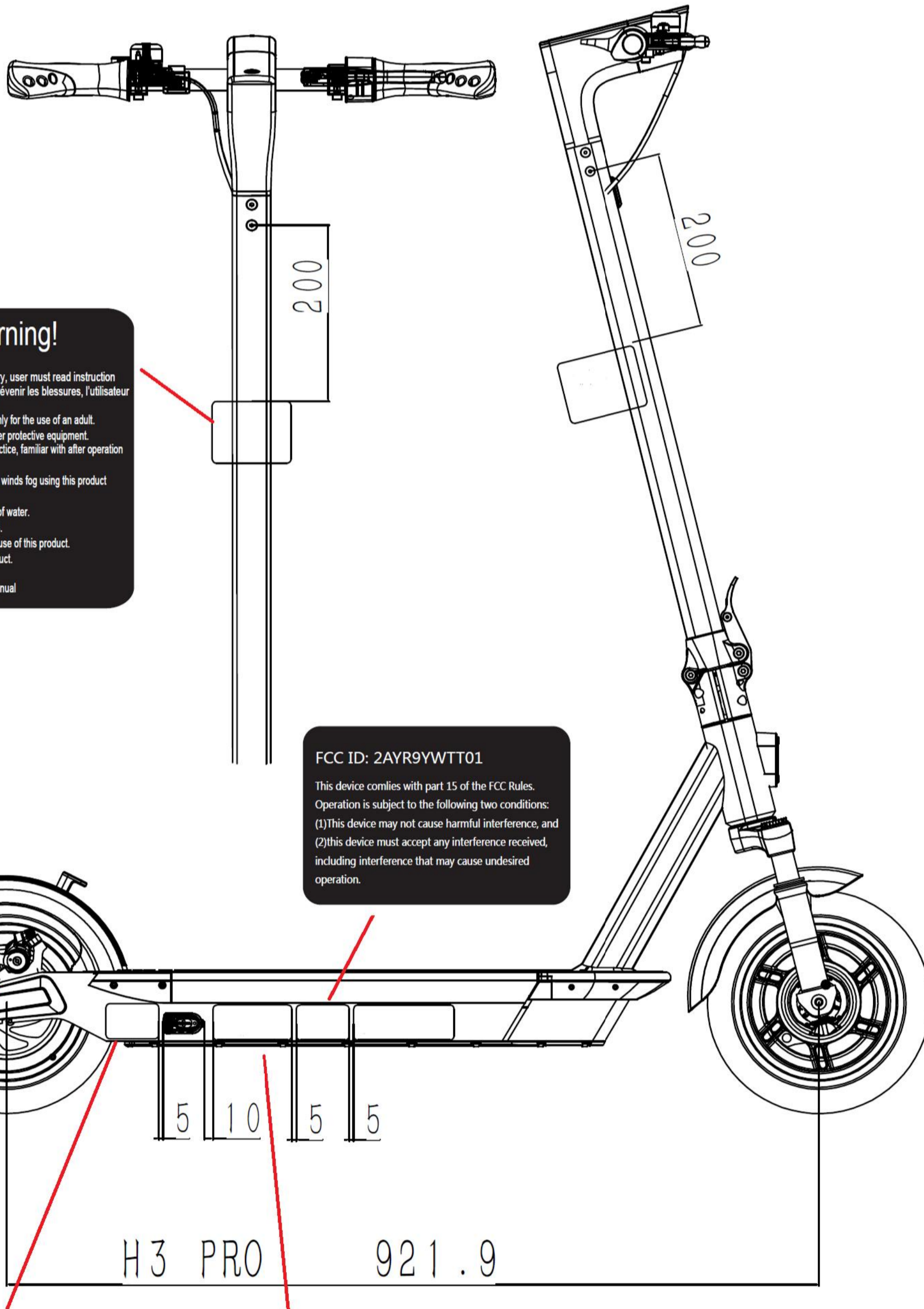

**Warning!**

1. WARNING – To reduce the risk of injury, user must read instruction manual. (AVERTISSEMENT - Pour prévenir les blessures, l'utilisateur doit lire le manuel d'utilisation)
2. This product is not suitable for children, only for the use of an adult.
3. When using wear helmets and, shoes other protective equipment.
4. In an open place (not in the driveway) practice, familiar with after operation Using this product.
5. Avoid bad weather such as snow and rain winds fog using this product
6. Avoid using this product in the night.
7. Never use near motor vehicles or bodies of water.
8. Do not use this product in oily or icy roads.
9. According to local regulations require the use of this product.
10. If there is damage to stop using this product.
11. Store Indoors When Not in use.
12. Use only charger as specified in user manual

**Warning: the motor surface overheating**

FCC ID: 2AYR9YWTT01  
 This device complies with part 15 of the FCC Rules. Operation is subject to the following two conditions:  
 (1) This device may not cause harmful interference, and  
 (2) this device must accept any interference received, including interference that may cause undesired operation.

**Warning: brake disc surface overheating**

**Warning!**

1. Please use the specified in the original charger, shut off the power switch before charging.
2. When charging, first open the charging hole cover, insert the plug of the charger output to recharge the hole, and then insert the plug of the charger input power socket.
3. The charger indicator lights in red, said the battery is charging, When the indicator light To green, said the Battery is complete.
4. Complete charging back cover tight protection cover.
5. Warning: be careful to get an electric shock, strictly forbid Disassembling.

**YADEA** Manufacturer: Yadea Technology Group co., Ltd  
 Dongsheng Road, Dacheng Industrial Zone,  
 Anzhen, Xishan District, Wuxi, Jiangsu, China  
 Product name: Electric scooter Model number: KS5pro  
 Motor power: 500 W Max speed: 35 km/h  
 Battery capacity: 36 VDC15.6 Ah Input voltage: 42 VDC, 2 A  
 Net weight: 45.76 lbs (20.8 Kg) Max rider weight: 242 lbs (110 Kg)  
 Manufacturing: 2nd, 2021 Execution standards: UL2272

IPX4