



CFR 47 FCC PART 15 SUBPART C

TEST REPORT

For

Central Controller Unit

MODEL NUMBER: H60A

PROJECT NUMBER: 4790218908

REPORT NUMBER: 4790218908-1

FCC ID: 2AYR9H60A

ISSUE DATE: Feb. 26, 2022

Prepared for

YADEA TECHNOLOGY GROUP CO., LTD.

Prepared by

UL-CCIC COMPANY LIMITED

No. 2, Chengwan Road, Suzhou Industrial Park, People's Republic of China

Tel: +86 512 6808 6400

Fax: +86 512 6808 4099

Website: www.ul.com

Form-ULID-008536-9 V1.0

The results reported herein have been performed in accordance with the laboratory's terms of accreditation. This report shall not be reproduced except in full without the written approval of the Laboratory. The results in this report apply to the test sample(s) mentioned above at the time of the testing period only and are not to be used to indicate applicability to other similar products.



Revision History

<u>Rev.</u>	<u>Issue Date</u>	<u>Revisions</u>	<u>Revised By</u>
V0	02/26/2022	Initial Issue	



Summary of Test Results			
Clause	Test Items	FCC Rules	Test Results
1	6dB Bandwidth	FCC Part 15.247 (a) (2)	Pass
2	Peak Conducted Output Power	FCC Part 15.247 (b) (3)	Pass
3	Power Spectral Density	FCC Part 15.247 (e)	Pass
4	Conducted Bandedge and Spurious Emission	FCC Part 15.247 (d)	Pass
5	Radiated Bandedge and Spurious Emission	FCC Part 15.247 (d) FCC Part 15.209 FCC Part 15.205	Pass
6	Conducted Emission Test for AC Power Port	FCC Part 15.207	N/A (Note 1)
7	Antenna Requirement	FCC Part 15.203	Pass

Note1: The product was powered by battery, so this test item is no need to test.
Note 2: The measurement result for the sample received is <Pass> according to < ANSI C63.10-2013, FCC CFR 47 Part 2, FCC CFR 47 Part 15C> when <Accuracy Method> decision rule is applied.



TABLE OF CONTENTS

1. ATTESTATION OF TEST RESULTS	6
2. TEST METHODOLOGY	7
3. FACILITIES AND ACCREDITATION	7
4. CALIBRATION AND UNCERTAINTY	8
4.1. <i>MEASURING INSTRUMENT CALIBRATION</i>	8
4.2. <i>MEASUREMENT UNCERTAINTY</i>	8
5. EQUIPMENT UNDER TEST	9
5.1. <i>DESCRIPTION OF EUT</i>	9
5.2. <i>MAXIMUM OUTPUT POWER</i>	9
5.3. <i>CHANNEL LIST</i>	9
5.4. <i>TEST CHANNEL CONFIGURATION</i>	10
5.5. <i>THE WORSE CASE CONFIGURATIONS</i>	10
5.6. <i>DESCRIPTION OF AVAILABLE ANTENNAS</i>	10
5.7. <i>THE WORSE CASE CONFIGURATIONS</i>	10
5.8. <i>TEST ENVIRONMENT</i>	11
5.9. <i>DESCRIPTION OF TEST SETUP</i>	12
5.10. <i>MEASURING INSTRUMENT AND SOFTWARE USED</i>	13
6. MEASUREMENT METHODS	14
7. ANTENNA PORT TEST RESULTS	15
7.1. <i>ON TIME AND DUTY CYCLE</i>	15
7.2. <i>6 dB DTS BANDWIDTH</i>	17
7.3. <i>PEAK CONDUCTED OUTPUT POWER</i>	20
7.4. <i>POWER SPECTRAL DENSITY</i>	23
7.5. <i>CONDUCTED BANDEDGE AND SPURIOUS EMISSIONS</i>	26
8. RADIATED TEST RESULTS	41
8.1. <i>RESTRICTED BANDEDGE</i>	47
8.2. <i>SPURIOUS EMISSIONS (1-3GHz)</i>	52
8.3. <i>SPURIOUS EMISSIONS (3-18GHz)</i>	58
8.4. <i>SPURIOUS EMISSIONS (18-26GHz)</i>	64
8.5. <i>SPURIOUS EMISSIONS (0.03-1 GHz)</i>	66
8.6. <i>SPURIOUS EMISSIONS BELOW 30M</i>	68



9. ANTENNA REQUIREMENTS 71



1. ATTESTATION OF TEST RESULTS

Applicant Information

Company Name: YADEA TECHNOLOGY GROUP CO., LTD.
Address: Dongsheng Road, Dacheng Industrial Zone, Anzhen, Xishan District Wuxi, China

Manufacturer Information

Company Name: YADEA TECHNOLOGY GROUP CO., LTD.
Address: Dongsheng Road, Dacheng Industrial Zone, Anzhen, Xishan District Wuxi, China

Factory Information

Company Name: Wuhan Hekang Power Technology CO., LTD
Address: No.6, Fozuling 3rd Road, Donghu Development Zone, Wuhan, Hubei, China

EUT Description

Product Name: Central Controller Unit
Model Name: H60A
Additional No.: /
Sample Number: 4445104
Data of Receipt Sample: Nov. 29, 2021
Test Date: Nov. 29, 2021 ~ Jan. 05, 2022

APPLICABLE STANDARDS	
STANDARD	TEST RESULTS
CFR 47 FCC PART 15 SUBPART C	PASS

Prepared By:
Tom Tang

Tom Tang
Project Engineer

Reviewed By:
Leon Wu

Leon Wu
Senior Engineer Project

Authorized By:
Chris Zhong

Chris Zhong
Laboratory Leader



2. TEST METHODOLOGY

The tests documented in this report were performed in accordance with FCC KDB 558074 D01 15.247 Meas Guidance v05r02, KDB 414788 D01 Radiated Test Site v01r01, ANSI C63.10-2013, FCC CFR 47 Part 2, FCC CFR 47 Part 15.

3. FACILITIES AND ACCREDITATION

Accreditation Certificate	<p>A2LA (Certificate No.: 4829.01) UL-CCIC COMPANY LIMITED has been assessed and proved to be in compliance with A2LA.</p> <p>FCC (FCC Designation No.: CN1247) UL-CCIC COMPANY LIMITED has been recognized to perform compliance testing on equipment subject to the Commission's Declaration of Conformity (DoC) and Certification rules.</p> <p>IC (IC Designation No.: 25056; CAB No.: CN0073) UL-CCIC COMPANY LIMITED has been recognized to perform compliance testing on equipment subject to the Commission's Declaration of Conformity (DoC) and Certification rules.</p>
---------------------------	---

Note 1: All tests measurement facilities use to collect the measurement data are located at No. 2, Chengwan Road, Suzhou Industrial Park, Suzhou 215122, People's Republic of China

Note 2: For below 30MHz, lab had performed measurements at test anechoic chamber and comparing to measurements obtained on an open field site. These measurements below 30MHz had been correlated to measurements performed on an OFS.

Note 3: The test anechoic chamber in UL-CCIC COMPANY LIMITED had been calibrated and compared to the open field sites and the test anechoic chamber is shown to be equivalent to or worst case from the open field site.



4. CALIBRATION AND UNCERTAINTY

4.1. MEASURING INSTRUMENT CALIBRATION

The measuring equipment utilized to perform the tests documented in this report has been calibrated in accordance with the manufacturer's recommendations and is traceable to recognize national standards.

4.2. MEASUREMENT UNCERTAINTY

Where relevant, the following measurement uncertainty levels have been estimated for tests performed on the apparatus:

Test Item	Uncertainty
Conduction emission	3.1dB
Radiation Emission test (include Fundamental emission) (9kHz-30MHz)	3.3dB
Radiation Emission test (include Fundamental emission) (30MHz-1GHz)	3.3dB
Radiation Emission test (1GHz to 26GHz) (include Fundamental emission)	3.9dB (1GHz-18GHz)
	4.2dB (18GHz-26.5GHz)
Note: This uncertainty represents an expanded uncertainty expressed at approximately the 95% confidence level using a coverage factor of k=2.	



5. EQUIPMENT UNDER TEST

5.1. DESCRIPTION OF EUT

Equipment	Central Controller Unit		
Model Name	H60A		
Product Description	Operation Frequency	2402 MHz ~ 2480 MHz	
	Modulation Type	Data Rate	
	GFSK	1Mbps	
Power Supply	DC 24V		
Bluetooth Version	LE		
Hardware Version	V1.0		

5.2. MAXIMUM OUTPUT POWER

Bluetooth Mode	Frequency (MHz)	Channel Number	Max Output Power(dBm)
BLE	2402-2480	0-39[40]	-3.59

5.3. CHANNEL LIST

Channel	Frequency (MHz)	Channel	Frequency (MHz)	Channel	Frequency (MHz)	Channel	Frequency (MHz)
0	2402	11	2424	22	2446	33	2468
1	2404	12	2426	23	2448	34	2470
2	2406	13	2428	24	2450	35	2472
3	2408	14	2430	25	2452	36	2474
4	2410	15	2432	26	2454	37	2476
5	2412	16	2434	27	2456	38	2478
6	2414	17	2436	28	2458	39	2480
7	2416	18	2438	29	2460		
8	2418	19	2440	30	2462		
9	2420	20	2442	31	2464		
10	2422	21	2444	32	2468		



5.4. TEST CHANNEL CONFIGURATION

Test Mode	Test Channel		Frequency
GFSK	Low Channel	CH 0	2402MHz
	Middle Channel	CH 19	2440MHz
	High Channel	CH 39	2480MHz

5.5. THE WORSE CASE CONFIGURATIONS

The Worse Case Power Setting Parameter under 2400 ~ 2483.5MHz Band				
Test Software		nRFgoStudio		
Modulation Type	Transmit Antenna Number	Test Channel		
		CH 00	CH 19	CH 39
GFSK	1	37	37	37

5.6. DESCRIPTION OF AVAILABLE ANTENNAS

Ant.	Frequency (MHz)	Antenna Type	Antenna Gain (dBi)
1	2402-2480	PCB Antenna	2.49

Test Mode	Transmit and Receive Mode	Description
BLE	<input checked="" type="checkbox"/> 1TX, 1RX	ANT 1 can be used as transmitting/receiving antenna.

5.7. THE WORSE CASE CONFIGURATIONS

For the product, there is only one transmission antenna, so only the worst data for the antenna1 is recorded in the report.

Worst-case data rates as provided by the client were:

Bluetooth Mode	Modulation Technology	Modulation Type	Data Rate (Mbps)
BLE	DTS	GFSK	1Mbit/s



5.8. TEST ENVIRONMENT

Environment Parameter	Selected Values During Tests	
Relative Humidity	55 ~ 65%	
Atmospheric Pressure:	1025Pa	
Temperature	TN	20 ~ 30°C
Voltage:	VL	N/A
	VN	DC 24V
	VH	N/A

Note: VL= Lower Extreme Test Voltage
VN= Nominal Voltage
VH= Upper Extreme Test Voltage
TN= Normal Temperature

5.9. DESCRIPTION OF TEST SETUP

SUPPORT EQUIPMENT

Item	Equipment	Brand Name	Model Name	P/N
1	Laptop	ThinkPad	E590	/
2	DC Power Supply	Tektronix	PWS2326	/

I/O CABLES

Cable No	Port	Connector Type	Cable Type	Cable Length(m)	Remarks
4	USB to TTL	USB to TTL	USB to TTL	1	/

ACCESSORIES

Item	Accessory	Brand Name	Model Name	Description
1	Lighting	/	/	Supplied by customer
2	Electric Load	/	/	Supplied by customer

TEST SETUP

The EUT can work in engineering mode with a software through a laptop.

SETUP DIAGRAM FOR TESTS

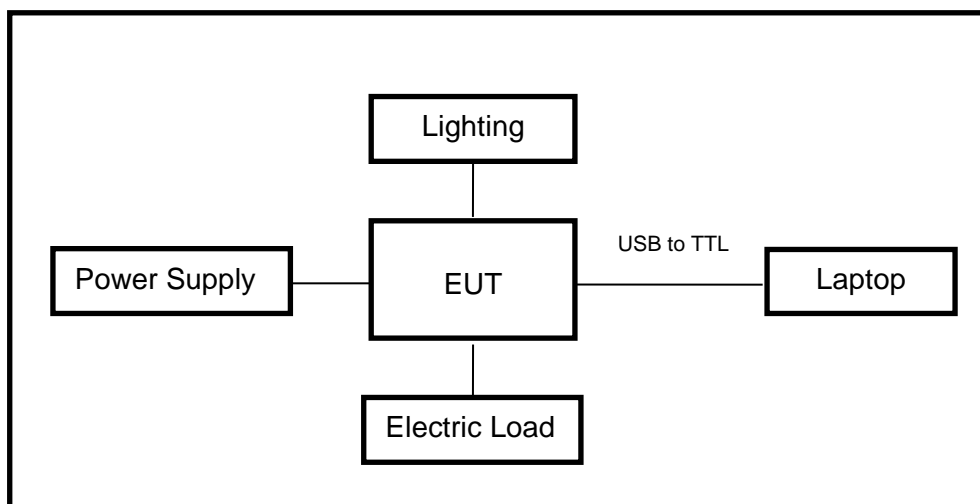



5.10. MEASURING INSTRUMENT AND SOFTWARE USED

Conducted Emissions (Instrument)							
Used	Equipment	Manufacturer	Model No.	Serial No.	Upper Last Cal.	Last Cal.	Next Cal.
<input checked="" type="checkbox"/>	EMI Test Receiver	R&S	ESR3	126700	2020-12-05	2021-12-04	2022-12-03
<input checked="" type="checkbox"/>	Two-Line V-Network	R&S	ENV216	126701	2020-12-05	2021-12-04	2022-12-03
<input checked="" type="checkbox"/>	Artificial Mains Networks	R&S	ENY81	126711	2020-10-13	2021-10-12	2022-10-11
Software							
Used	Description		Manufacturer	Name	Version		
<input checked="" type="checkbox"/>	Test Software for Conducted disturbance		R&S	EMC32	Ver. 9.25		
Radiated Emissions (Instrument)							
Used	Equipment	Manufacturer	Model No.	Serial No.	Upper Last Cal.	Last Cal.	Next Cal.
<input checked="" type="checkbox"/>	Spectrum Analyzer	Keysight	N9010B	155727	2020-05-10	2021-05-09	2022-05-08
<input checked="" type="checkbox"/>	EMI test receiver	R&S	ESR26	126703	2020-12-05	2021-12-04	2022-12-03
<input checked="" type="checkbox"/>	Receiver Antenna (9kHz-30MHz)	Schwarzbeck	FMZB 1513	155456	2018-06-15	2021-06-03	2024-06-02
<input checked="" type="checkbox"/>	Receiver Antenna (30MHz-1GHz)	SunAR RF Motion	JB1	177821	/	2019-01-28	2022-01-27
<input checked="" type="checkbox"/>	Receiver Antenna (1GHz-18GHz)	R&S	HF907	126705	2018-01-27	2019-01-27	2022-01-26
<input checked="" type="checkbox"/>	Receiver Antenna (18GHz-26.5GHz)	Schwarzbeck	BBHA9170	126706	2018-02-07	2019-01-05	2022-01-04
<input checked="" type="checkbox"/>	Pre-amplification (To 18GHz)	Compliance Direction System Inc.	PAP-1G18-50	178825	2020-02-20	2021-03-26	2022-03-25
<input checked="" type="checkbox"/>	Pre-amplification (To 26.5GHz)	R&S	SCU-26D	135391	2020-12-05	2021-12-04	2022-12-03
<input checked="" type="checkbox"/>	Band Reject Filter	Wainwright	WRCJV8-2350-2400-2483.5-2533.5-40SS	1	2020-05-10	2021-05-09	2022-05-08
<input checked="" type="checkbox"/>	Highpass Filter	Wainwright	WHKX10-2700-3000-18000-40SS	2	2020-05-10	2021-05-09	2022-05-08
Software							
Used	Description		Manufacturer	Name	Version		
<input checked="" type="checkbox"/>	Test Software for Radiated disturbance		Tonscend	TS+	Ver. 2.5		
Other instruments							
Used	Equipment	Manufacturer	Model No.	Serial No.	Upper Last Cal.	Last Cal.	Next Cal.
<input checked="" type="checkbox"/>	Spectrum Analyzer	Keysight	N9010B	155368	2020-05-10	2021-05-09	2022-05-08
<input checked="" type="checkbox"/>	Power Meter	Keysight	U2021XA	155370	2020-05-10	2021-05-09	2022-05-08



6. MEASUREMENT METHODS

No.	Test Item	KDB Name	Section
1	6dB Bandwidth	KDB 558074 D01 15.247 Meas Guidance v05r02	8.2
2	Output Power	KDB 558074 D01 15.247 Meas Guidance v05r02	8.3.1.3/8.3.2.3
3	Power Spectral Density	KDB 558074 D01 15.247 Meas Guidance v05r02	8.4
4	Out-of-band emissions in non-restricted bands	KDB 558074 D01 15.247 Meas Guidance v05r02	8.5
5	Out-of-band emissions in restricted bands	KDB 558074 D01 15.247 Meas Guidance v05r02	8.6
6	Band-edge	KDB 558074 D01 15.247 Meas Guidance v05r02	8.7
7	Conducted Emission Test for AC Power Port	ANSI C63.10-2013	6.2



7. ANTENNA PORT TEST RESULTS

7.1. ON TIME AND DUTY CYCLE

LIMITS

None; for reporting purposes only

PROCEDURE

KDB 558074 Zero-Span Spectrum Analyzer Method

TEST SETUP

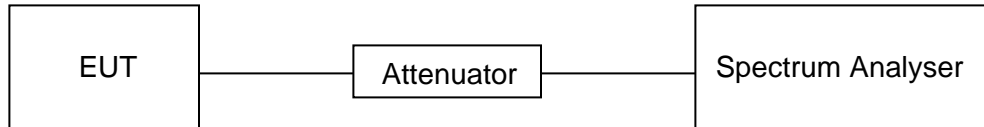

TEST ENVIRONMENT

Temperature	20°C	Relative Humidity	56%
Atmosphere Pressure	101kPa	Test Voltage	DC 24V

RESULTS

Mode	On Time (msec)	Period (msec)	Duty Cycle x (Linear)	Duty Cycle (%)	Duty Cycle Correction Factor (db)	1/T Minimum VBW (KHz)
BLE	0.3893	0.62505	0.6228	62.28%	2.06	2.57

Note:

Duty Cycle Correction Factor=10log (1/x).

Where: x is Duty Cycle (Linear)

Where: T is On Time

If that calculated VBW is not available on the analyzer then the next higher value should be used.

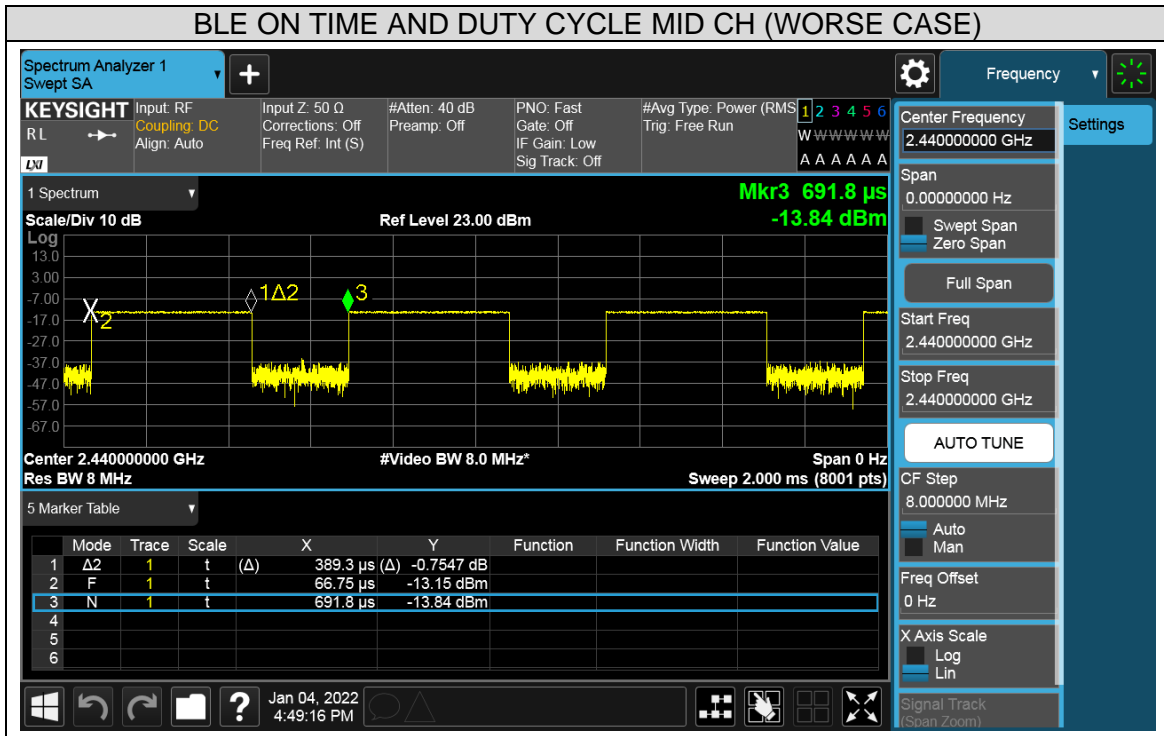

7.2. 6 dB DTS BANDWIDTH

LIMITS

FCC Part15 (15.247) Subpart C			
Section	Test Item	Limit	Frequency Range (MHz)
FCC 15.247(a)(2)	6dB Bandwidth	$\geq 500\text{KHz}$	2400-2483.5

TEST PROCEDURE

Connect the UUT to the spectrum analyser and use the following settings:

Center Frequency	The center frequency of the channel under test
Detector	Peak
RBW	For 6 dB Bandwidth :100K
VBW	For 6dB Bandwidth : $\geq 3 \times \text{RBW}$
Trace	Max hold
Sweep	Auto couple

Allow the trace to stabilize and measure the maximum width of the emission that is constrained by the frequencies associated with the two outermost amplitude points (upper and lower frequencies) that are attenuated by 6 dB relative to the maximum level measured in the fundamental emission.

TEST SETUP

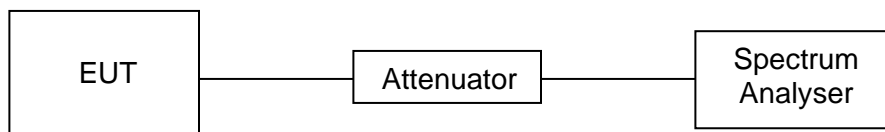

TEST ENVIRONMENT

Temperature	20°C	Relative Humidity	56%
Atmosphere Pressure	101kPa	Test Voltage	DC 24V



RESULTS

Channel	Frequency (MHz)	6dB bandwidth (MHz)	Limit (kHz)	Result
CH00	2402	0.6698	500	Pass
CH19	2440	0.6908	500	Pass
CH39	2480	0.7080	500	Pass

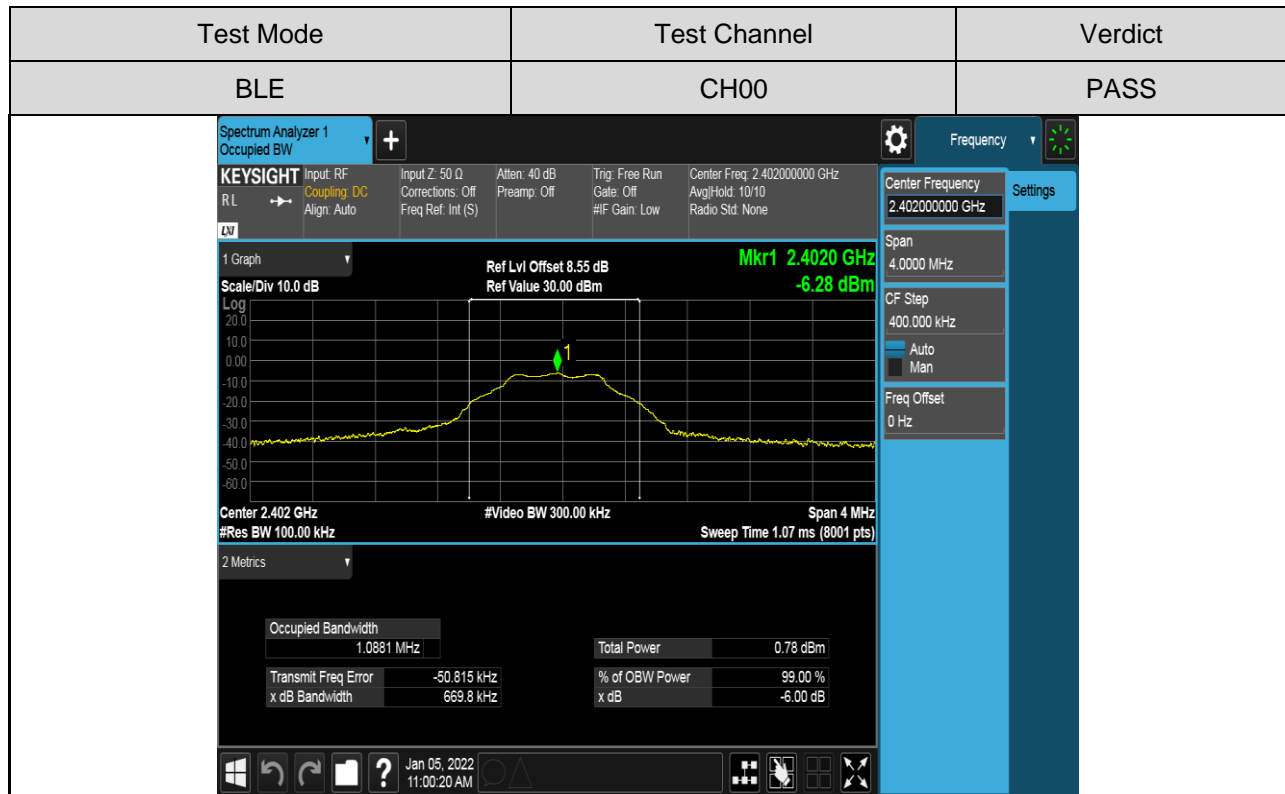

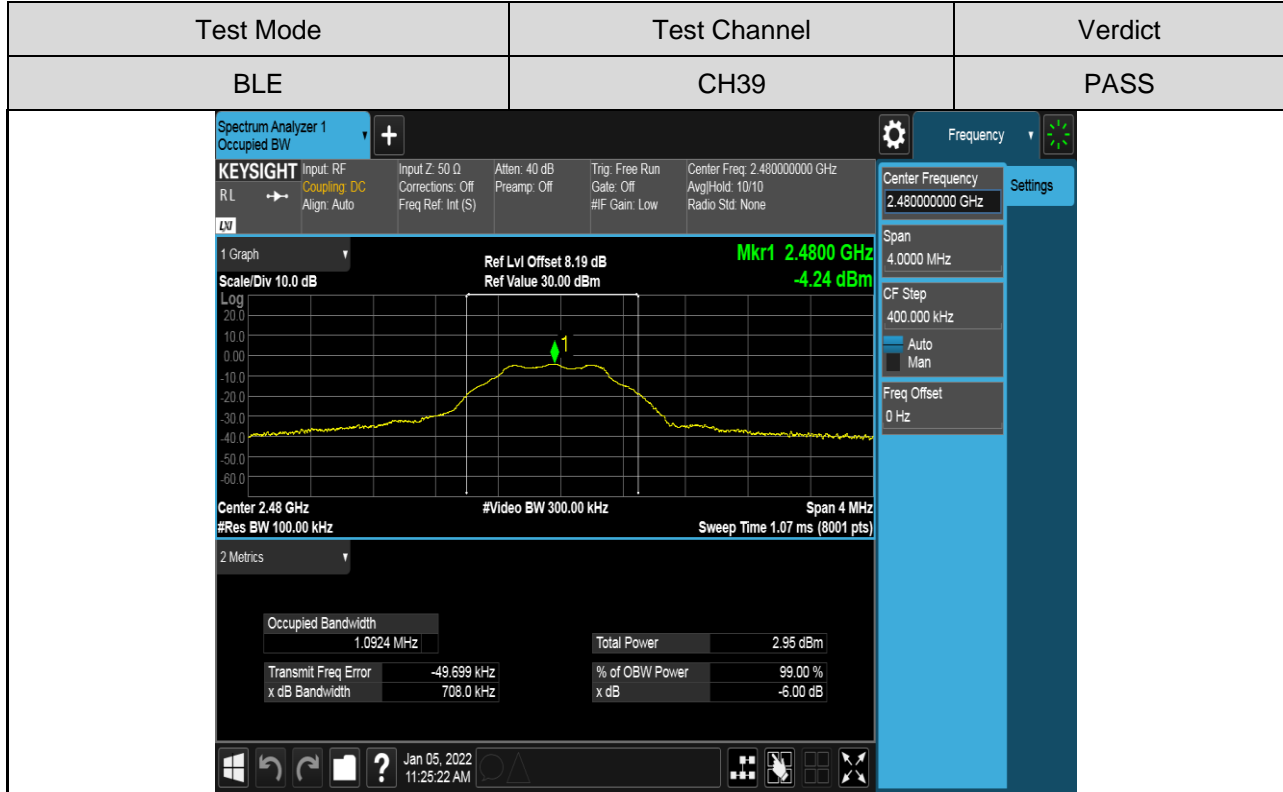
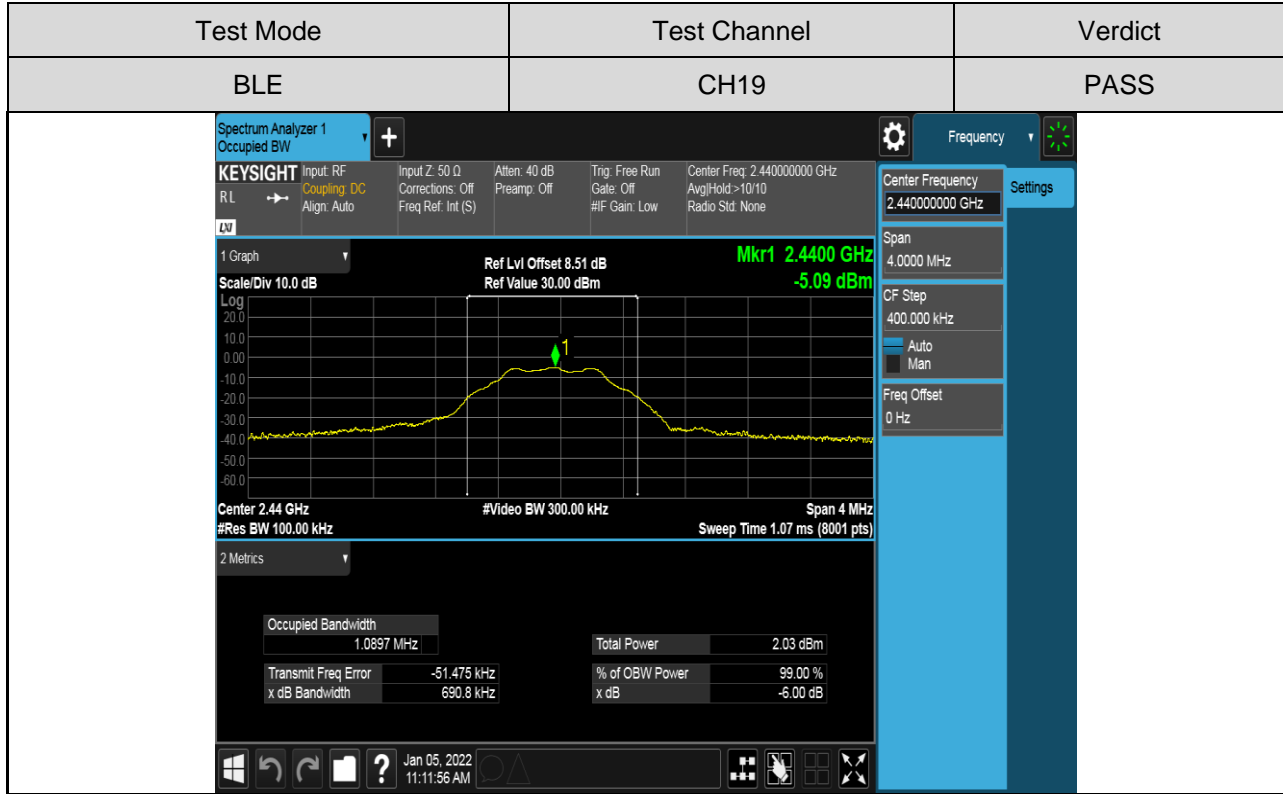



7.3. PEAK CONDUCTED OUTPUT POWER

LIMITS

CFR 47 FCC Part15 (15.247) Subpart C			
Section	Test Item	Limit	Frequency Range (MHz)
CFR 47 FCC 15.247(b)(3)	Peak Output Power	1 watt or 30dBm (See note1)	2400-2483.5
Note: If transmitting antennas of directional gain greater than 6 dBi are used, both the maximum conducted output power and the maximum power spectral density shall be reduced by the amount in dB that the directional gain of the antenna exceeds 6dBi.			

TEST PROCEDURE

Refer to the subclause 8.3.1.1 of KDB558074 and the subclause 11.9.1.1 of ANSI C63.10. Place the EUT on the table and set it in the transmitting mode. Allow trace to fully stabilize and use peak marker function to determine the peak amplitude level.

TEST SETUP

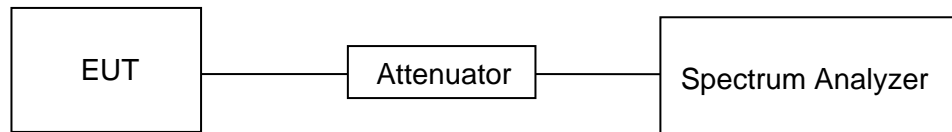

TEST ENVIRONMENT

Temperature	20°C	Relative Humidity	56%
Atmosphere Pressure	101kPa	Test Voltage	DC 24V



RESULTS

Test Channel	Frequency	Maximum Conducted Output Power(PK)	Result
	(MHz)	(dBm)	
CH00	2402	-5.44	PASS
CH19	2440	-4.36	PASS
CH39	2480	-3.59	PASS

Test Graphs:

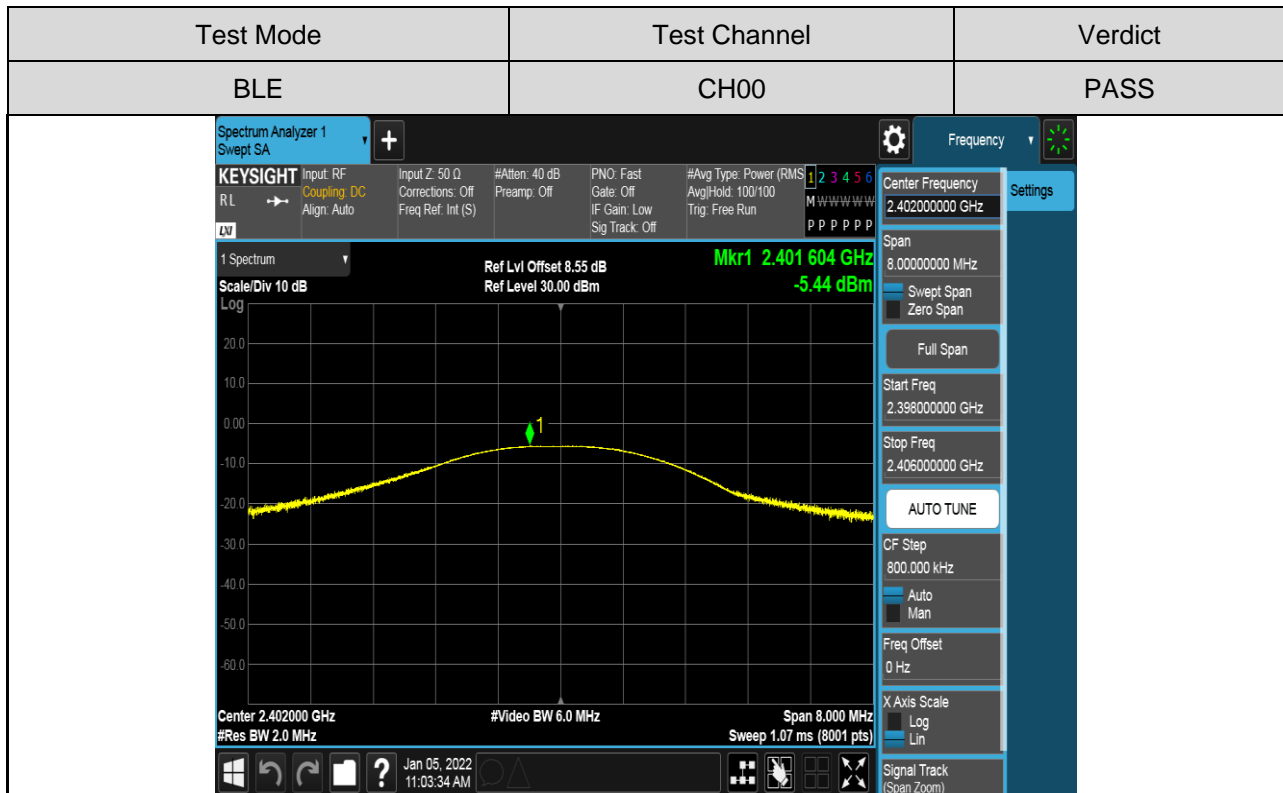

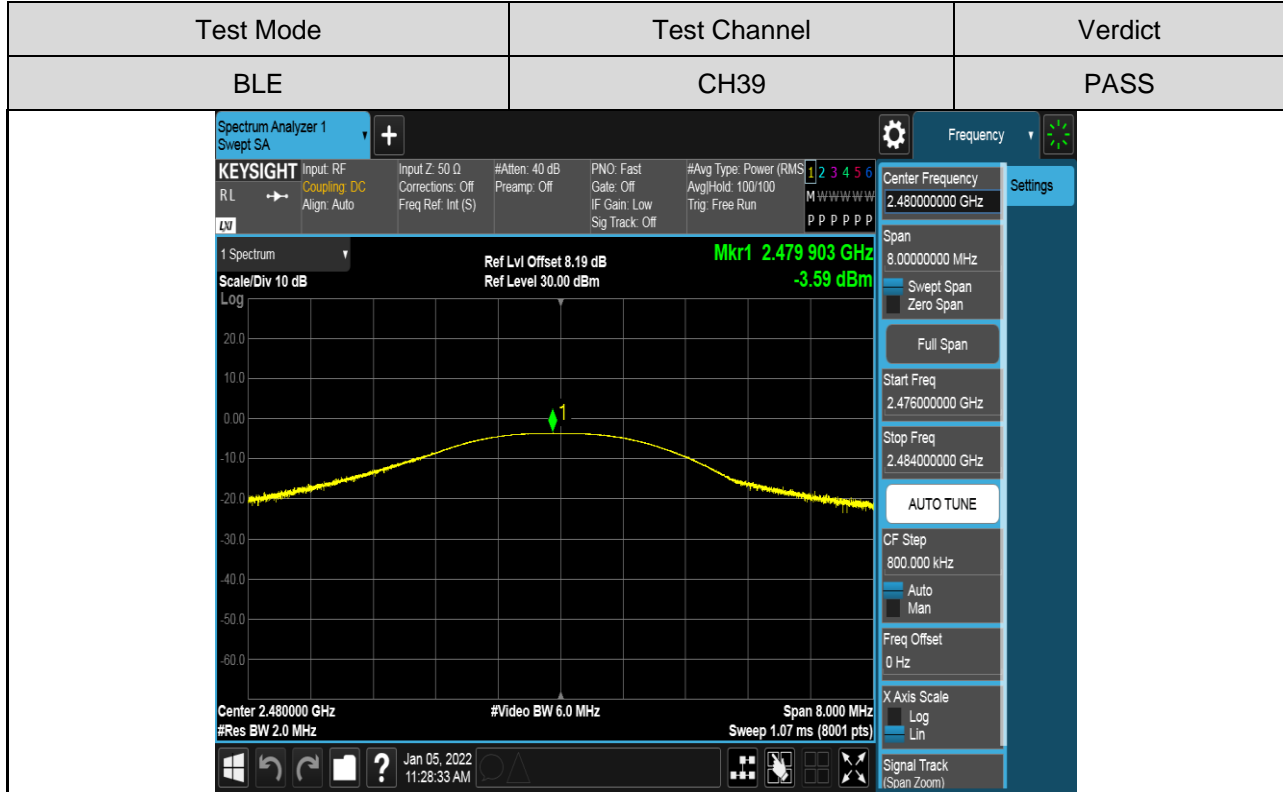
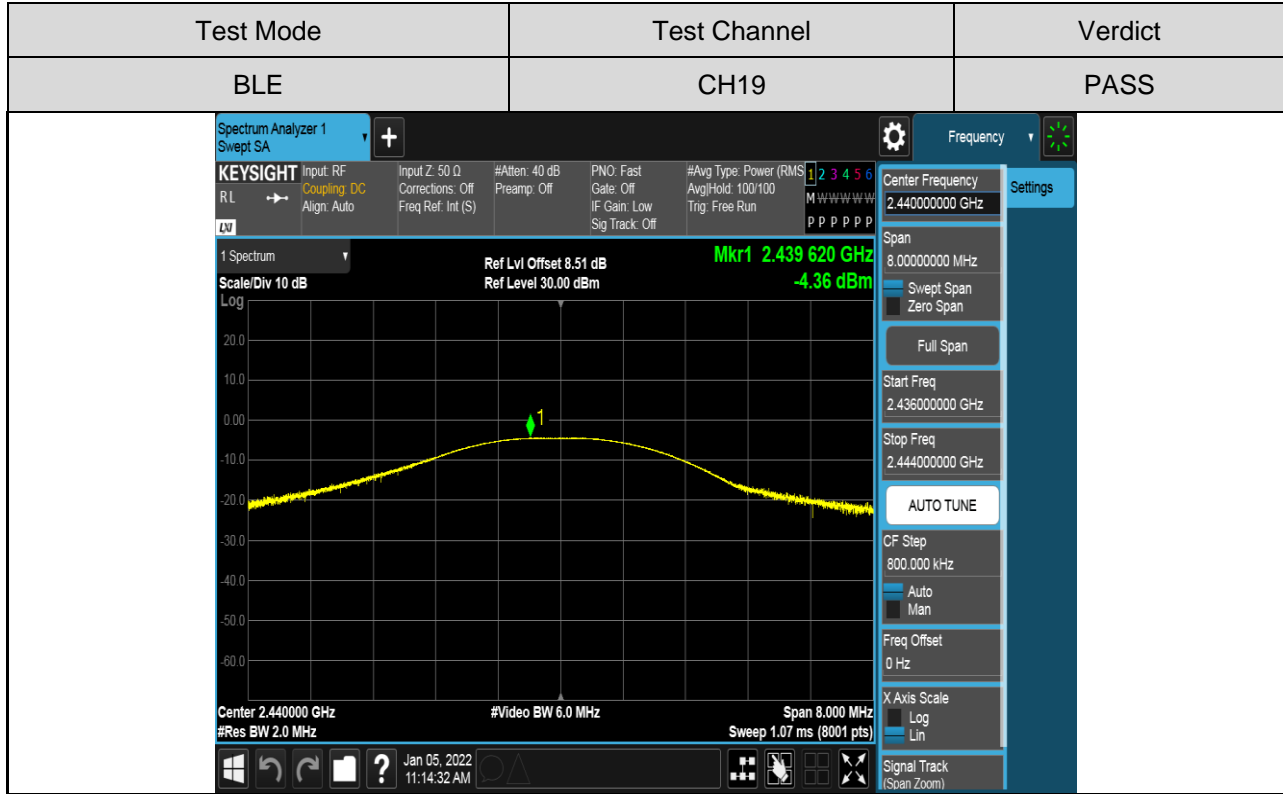

7.4. POWER SPECTRAL DENSITY

LIMITS

CFR 47 FCC Part15 (15.247) Subpart C			
Section	Test Item	Limit	Frequency Range (MHz)
CFR 47 FCC §15.247 (e)	Power Spectral Density	8 dBm/3 kHz (See note1)	2400-2483.5
Note: 1. If transmitting antennas of directional gain greater than 6 dBi are used, both the maximum conducted output power and the maximum power spectral density shall be reduced by the amount in dB that the directional gain of the antenna exceeds 6dBi.			

TEST PROCEDURE

Connect the UUT to the spectrum analyser and use the following settings:

Center Frequency	The centre frequency of the channel under test
Detector	Peak
RBW	$3 \text{ kHz} \leq \text{RBW} \leq 100 \text{ kHz}$
VBW	$\geq 3 \times \text{RBW}$
Span	1.5 x DTS bandwidth
Trace	Max hold
Sweep time	Auto couple.

Allow trace to fully stabilize and use the peak marker function to determine the maximum amplitude level within the RBW.

If measured value exceeds limit, reduce RBW (no less than 3 kHz) and repeat.

TEST SETUP

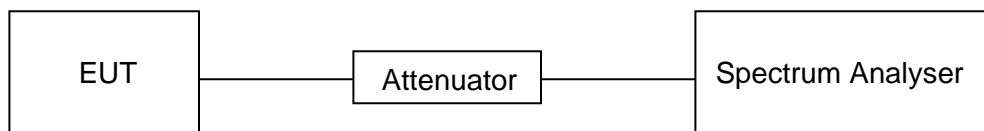

TEST ENVIRONMENT

Temperature	20°C	Relative Humidity	56%
Atmosphere Pressure	101kPa	Test Voltage	DC 24V



RESULTS

Test Channel	Frequency	Power Spectral Density	Limit	Result
	(MHz)	(dBm/100kHz)	(dBm/3kHz)	
CH00	2402 MHz	-6.19	8	PASS
CH19	2440 MHz	-5.05	8	PASS
CH39	2480 MHz	-4.26	8	PASS

Test Graphs:

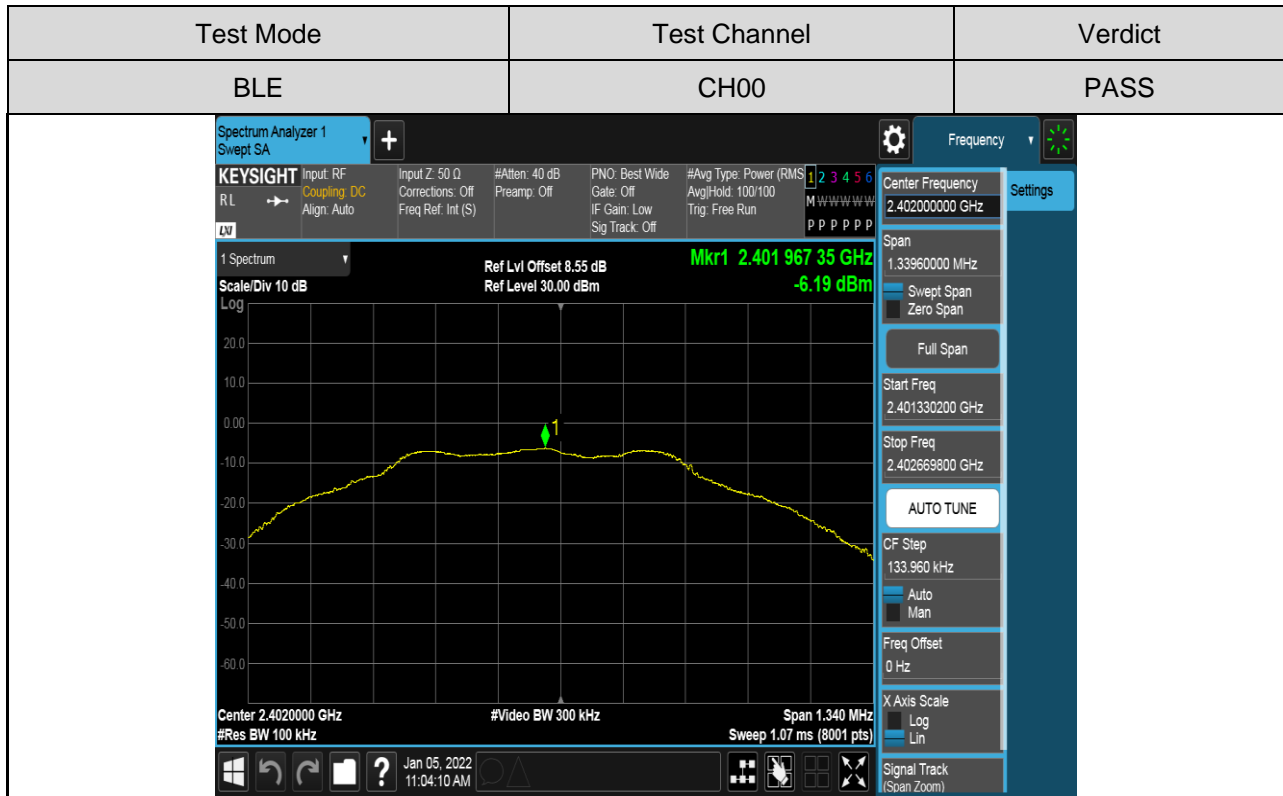

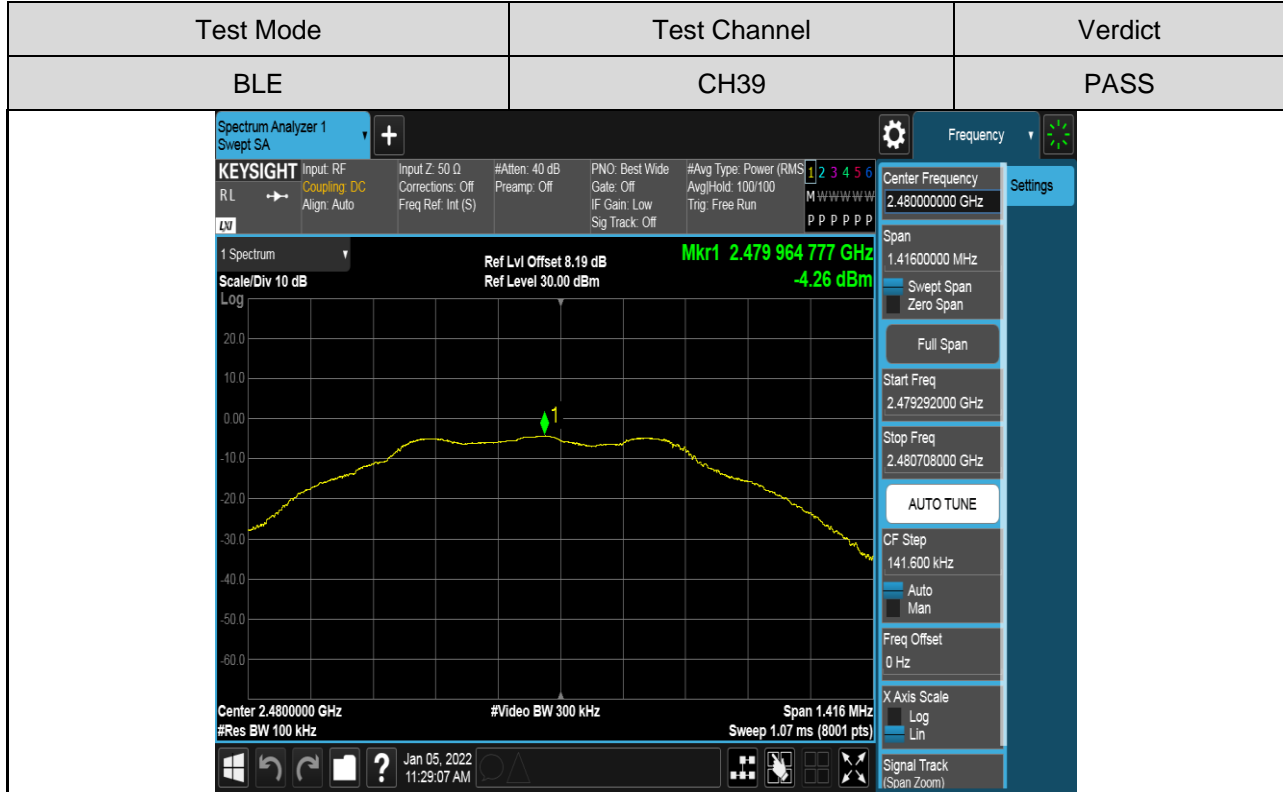
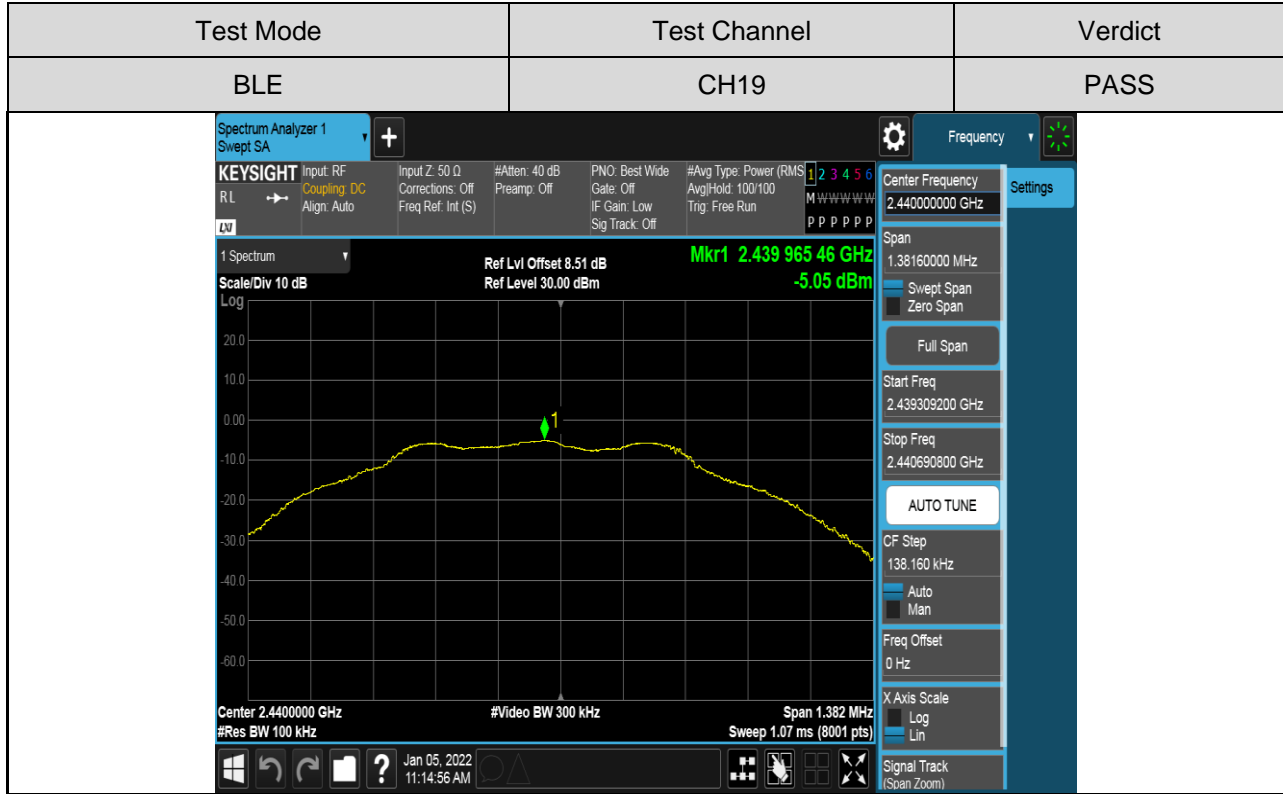



7.5. CONDUCTED BANDEGE AND SPURIOUS EMISSIONS

LIMITS

CFR 47 FCC Part15 (15.247) Subpart C		
Section	Test Item	Limit
CFR 47 FCC §15.247 (d)	Conducted Bandedge and Spurious Emissions	at least 20 dB below that in the 100 kHz bandwidth within the band that contains the highest level of the desired power

TEST PROCEDURE

Connect the UUT to the spectrum analyser and use the following settings:

Center Frequency	The centre frequency of the channel under test
Detector	Peak
RBW	100K
VBW	$\geq 3 \times \text{RBW}$
Span	1.5 x DTS bandwidth
Trace	Max hold
Sweep time	Auto couple.

Use the peak marker function to determine the maximum PSD level.

Span	Set the center frequency and span to encompass frequency range to be measured
Detector	Peak
RBW	100K
VBW	$\geq 3 \times \text{RBW}$
measurement points	$\geq \text{span}/\text{RBW}$
Trace	Max hold
Sweep time	Auto couple.

Use the peak marker function to determine the maximum amplitude level.

TEST SETUP

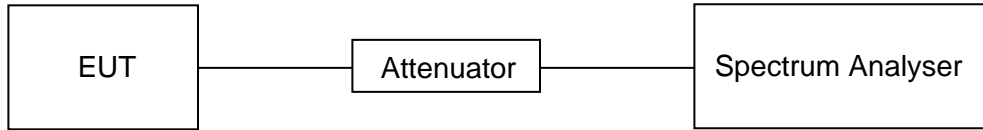

TEST ENVIRONMENT

Temperature	20°C	Relative Humidity	56%
Atmosphere Pressure	101kPa	Test Voltage	DC 24V

Part 1: Conducted Bandedge

RESULTS

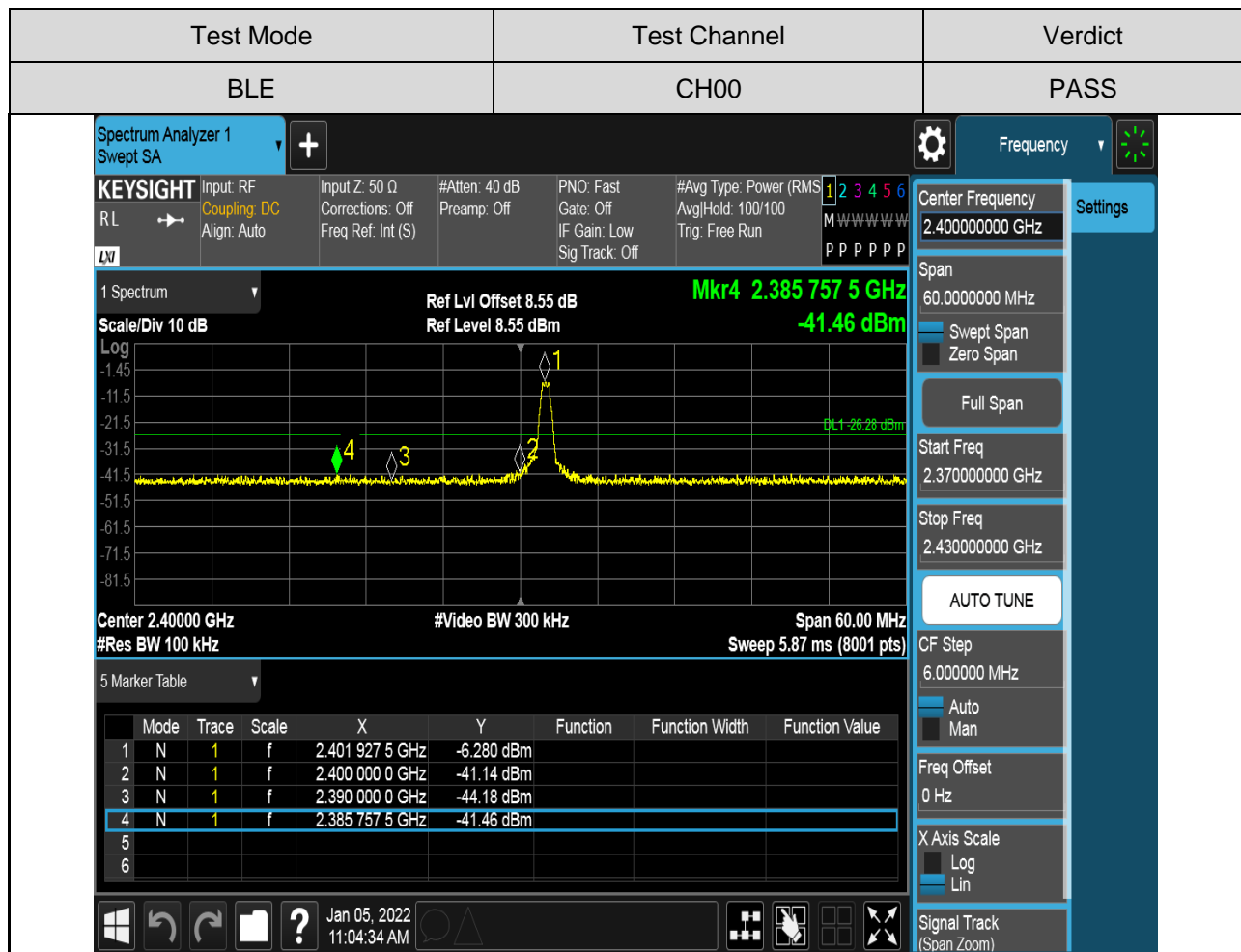

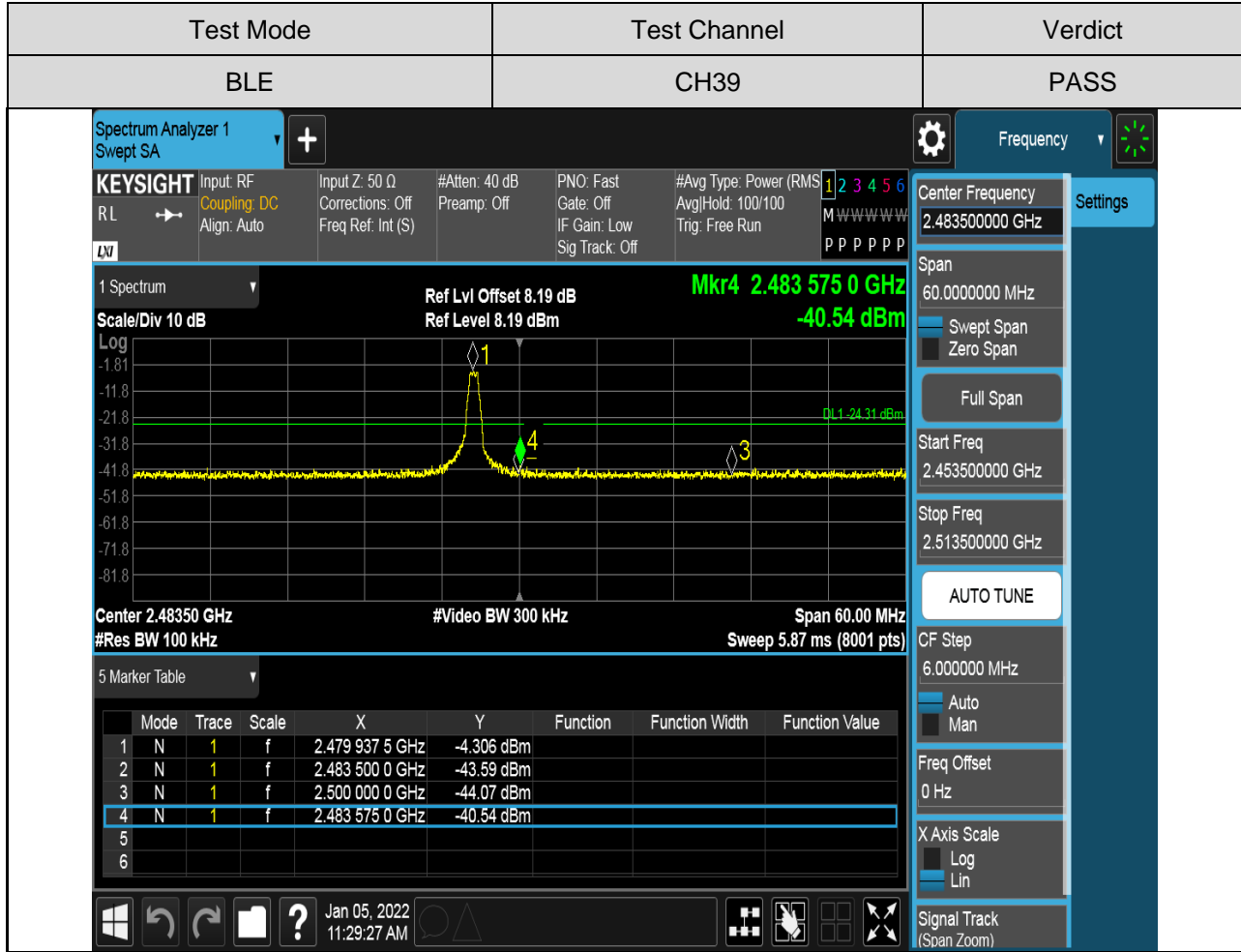



Part 2: Conducted Emission

Test Plots

Test Mode	Channel	Verdict
BLE	CH00	PASS

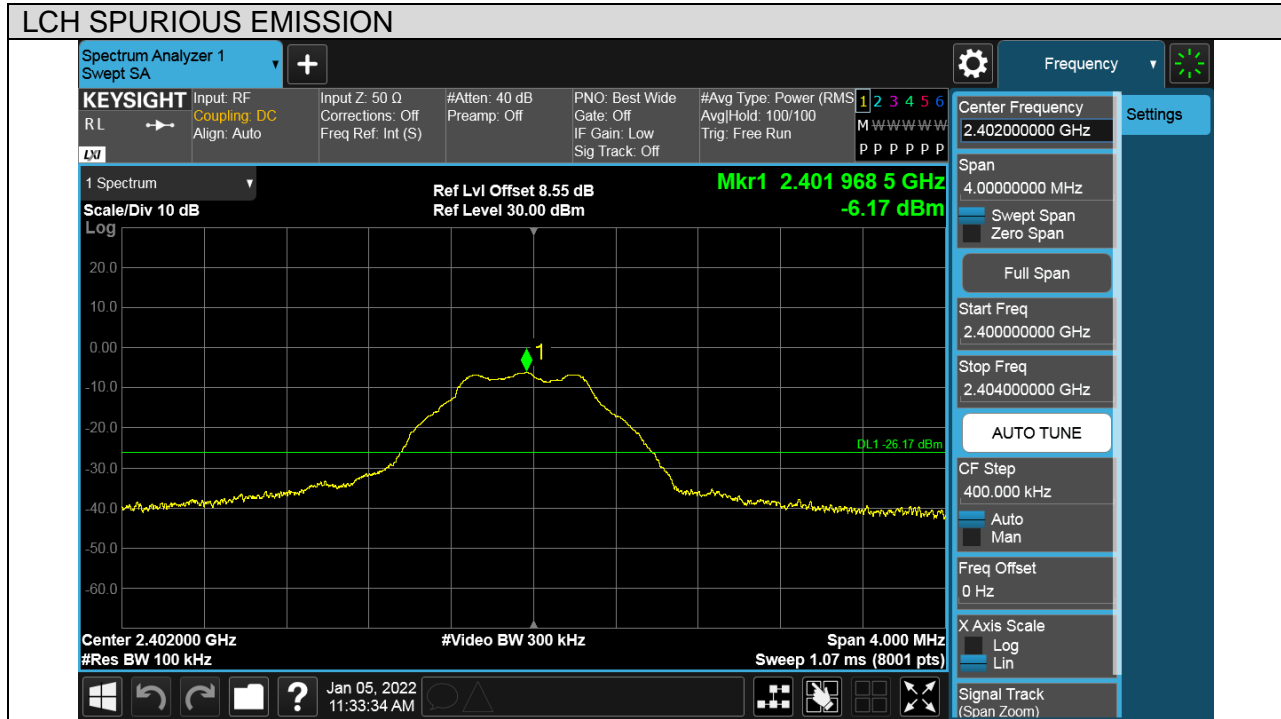



Puw test Plot

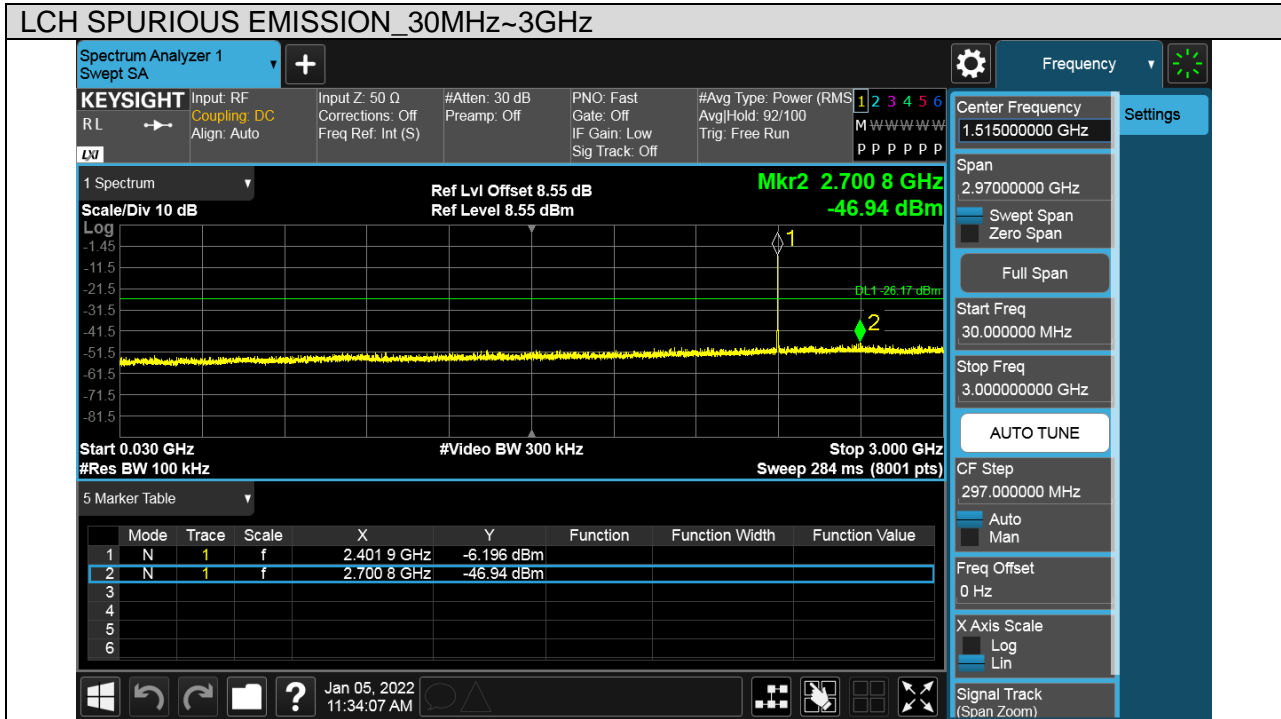

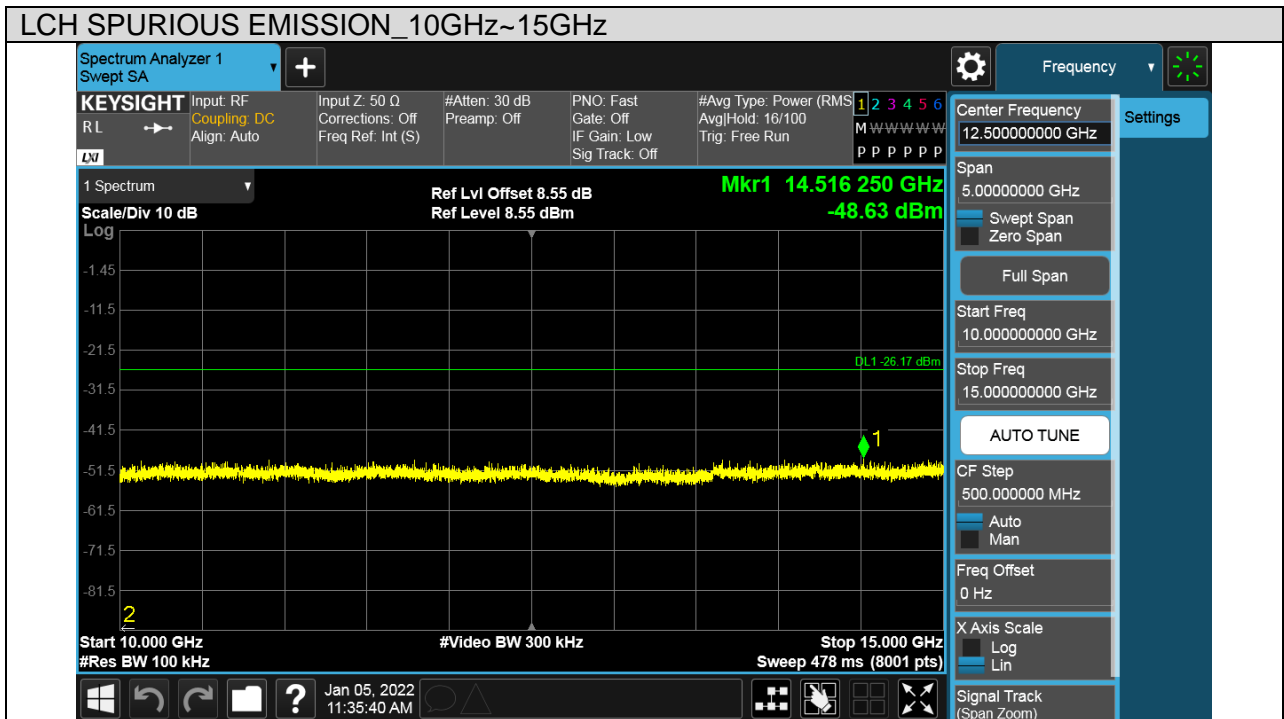
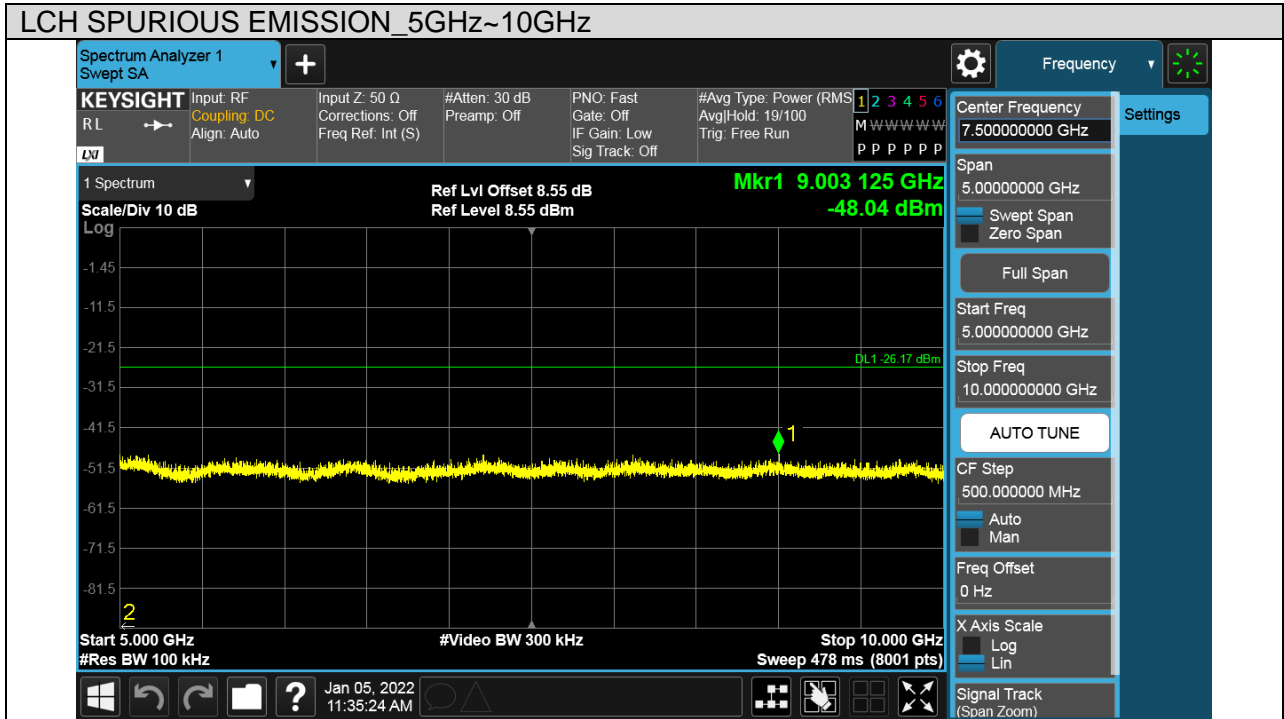

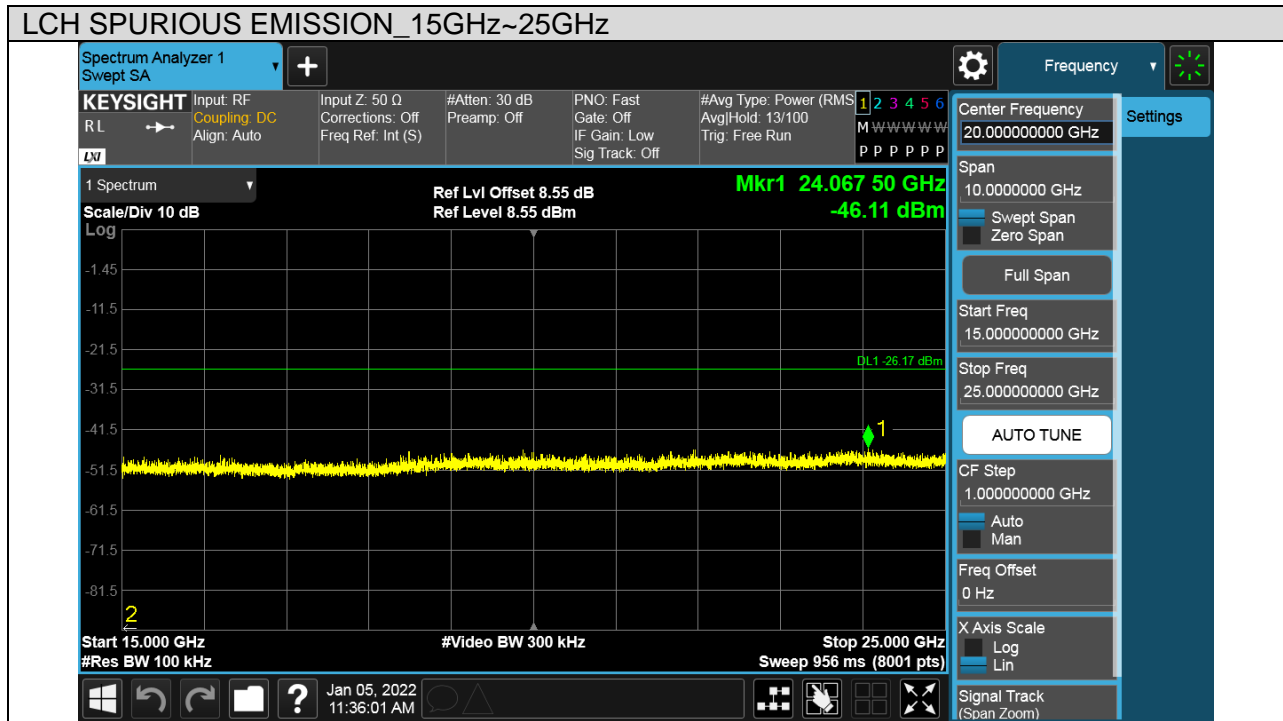



Test Mode	Channel	Verdict
BLE	CH19	PASS

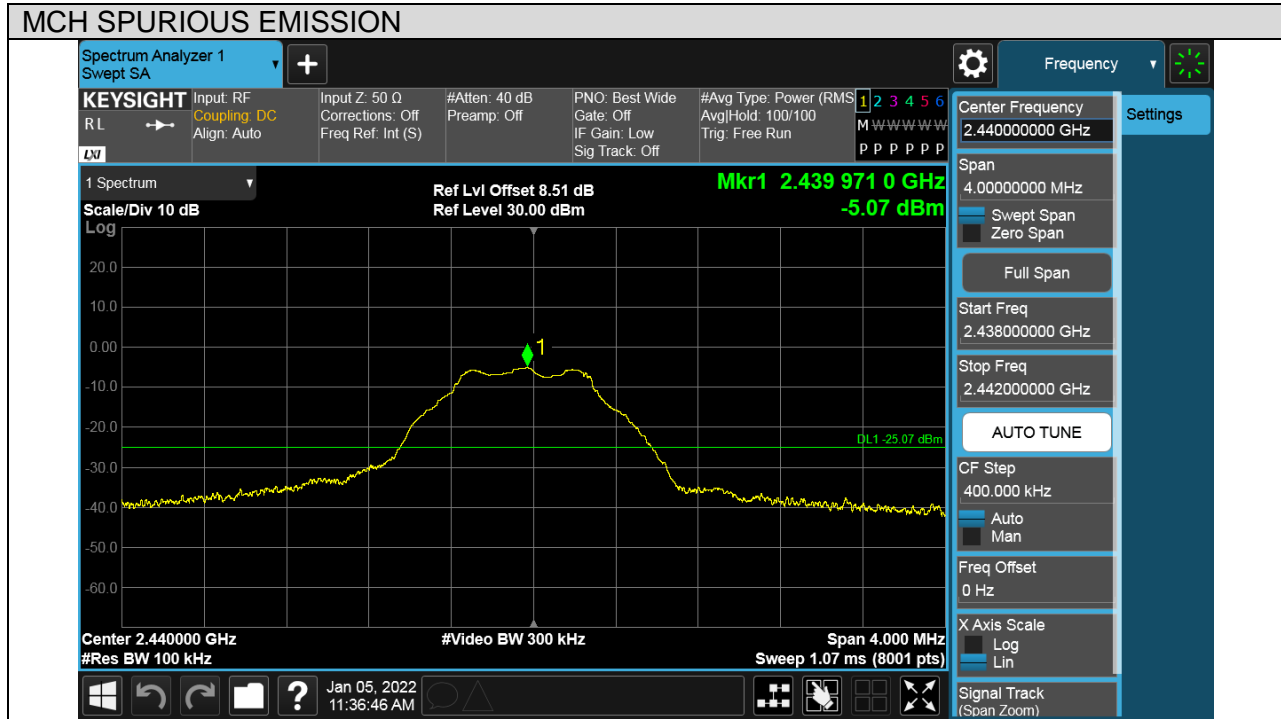

Puw test Plot

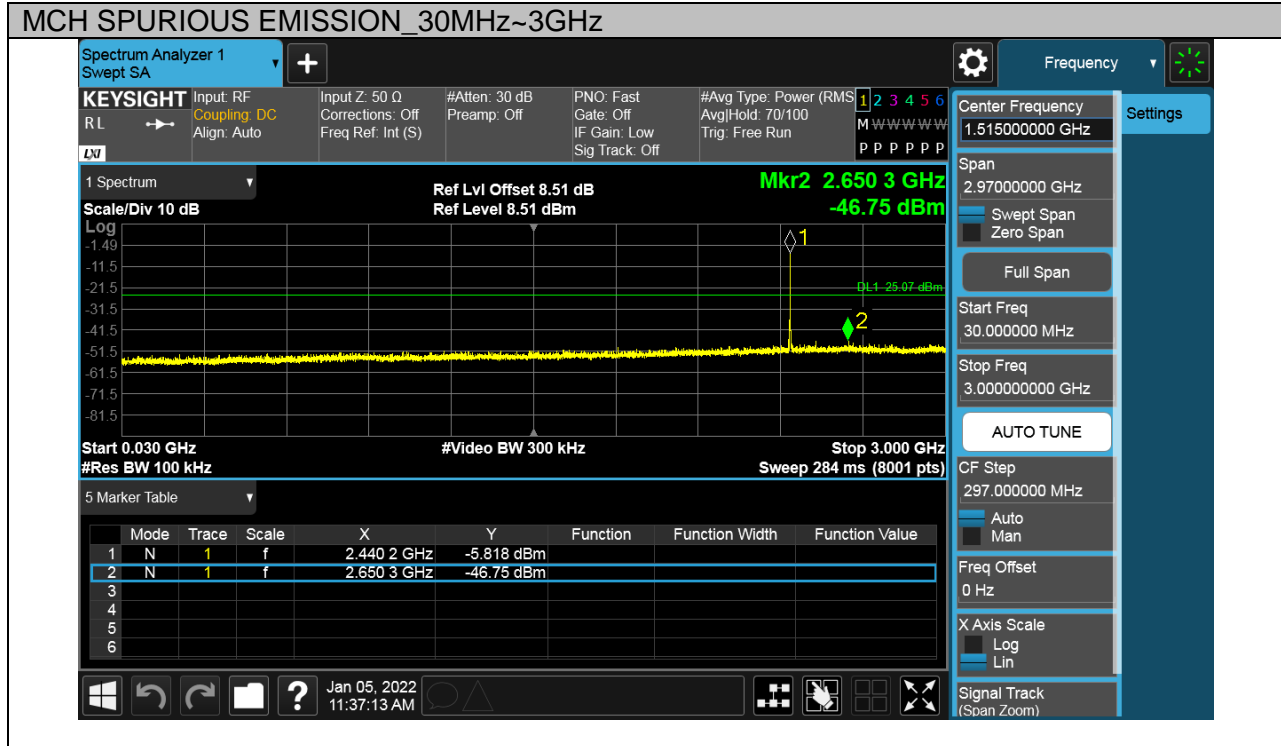



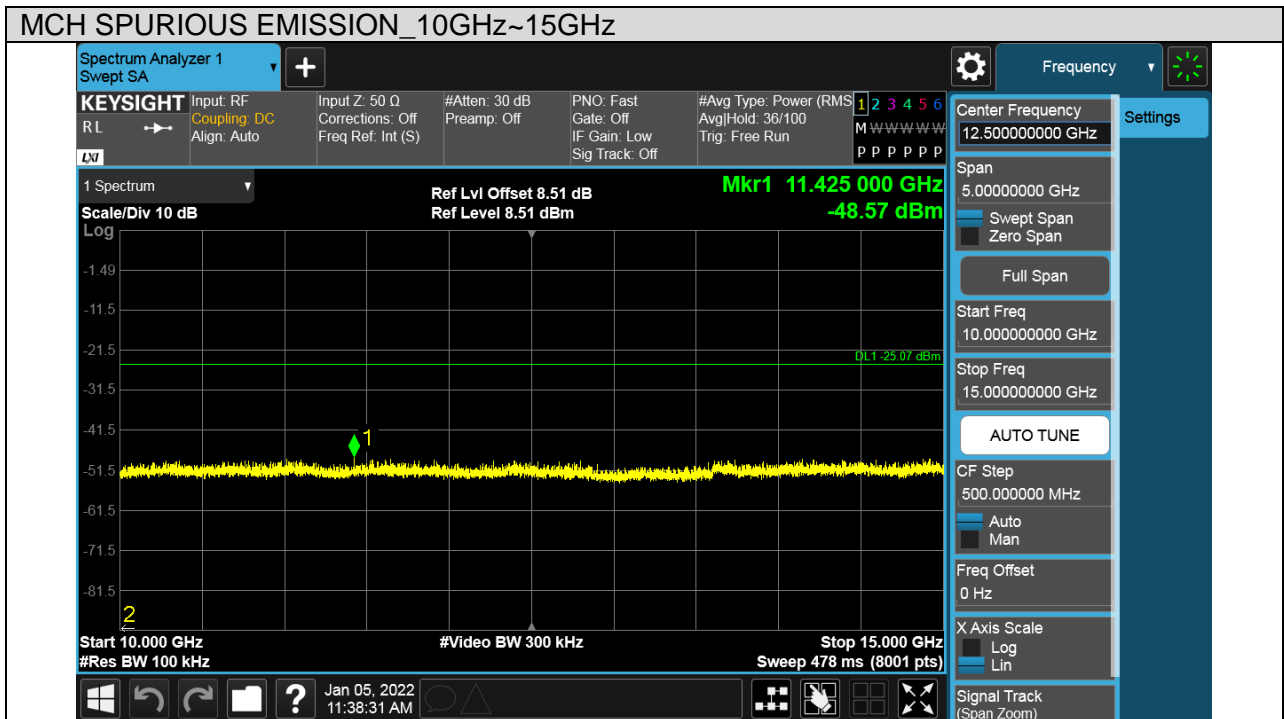
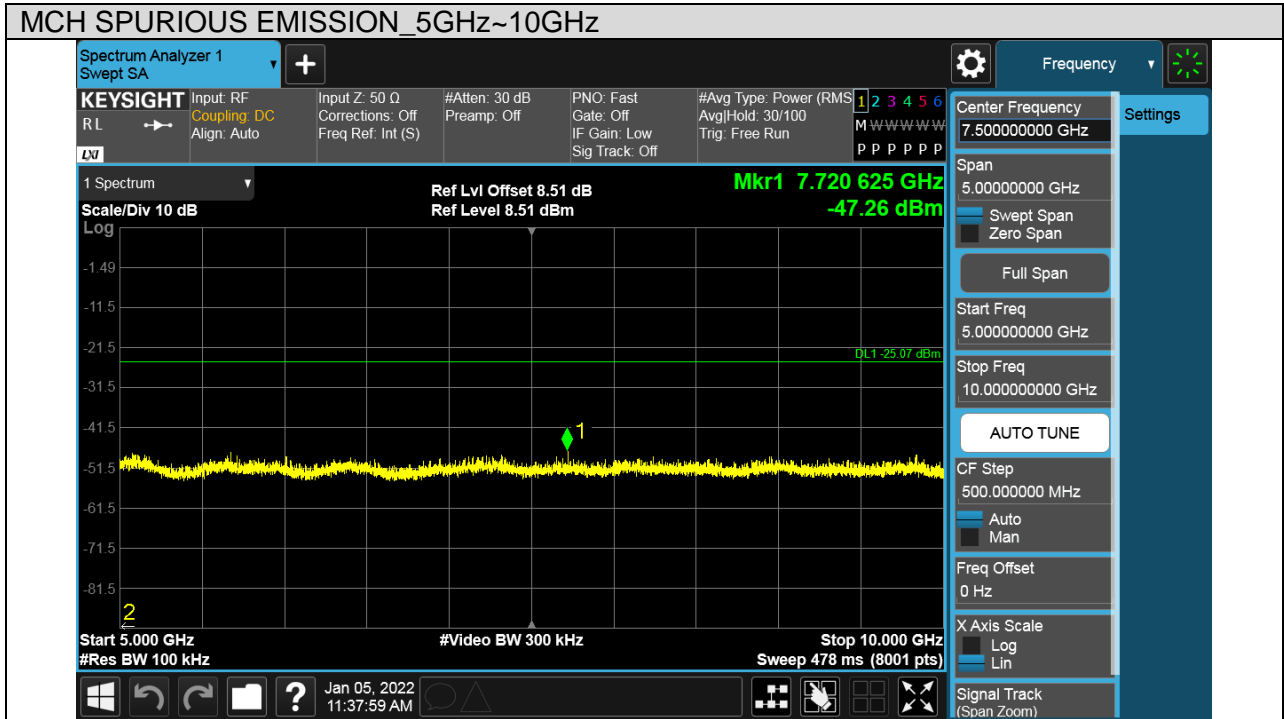

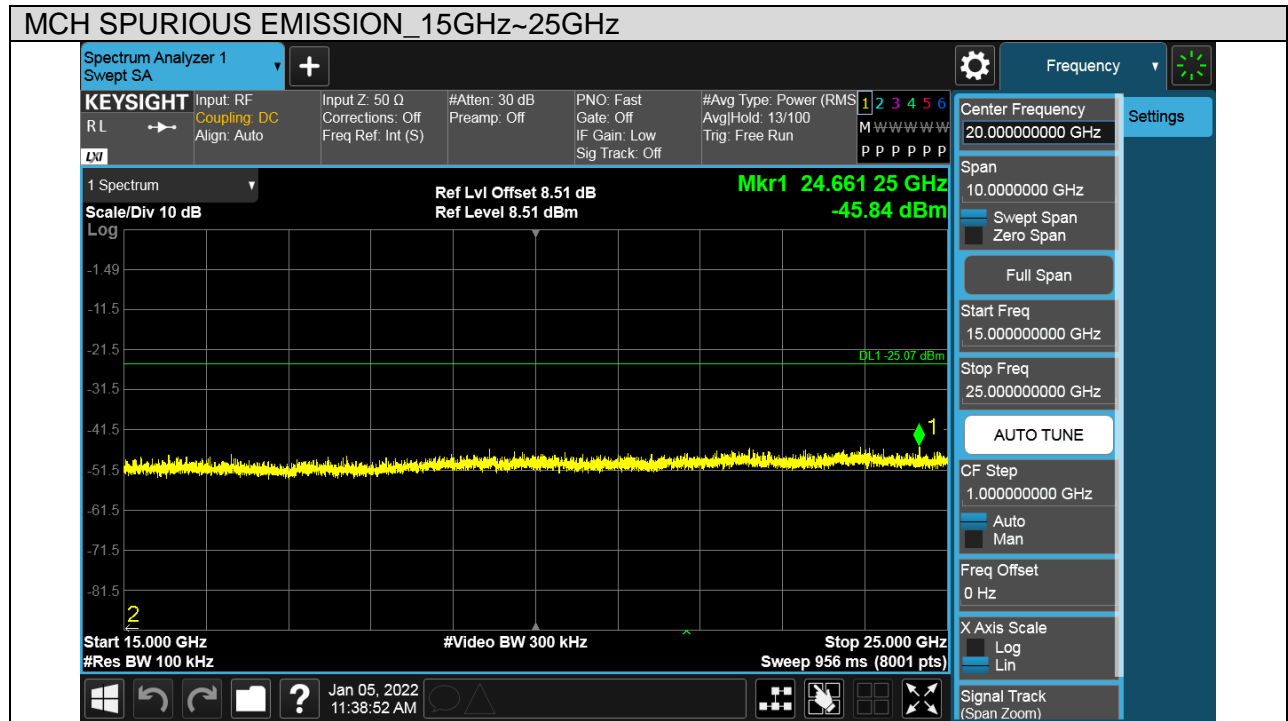



Test Mode	Channel	Verdict
BLE	CH39	PASS

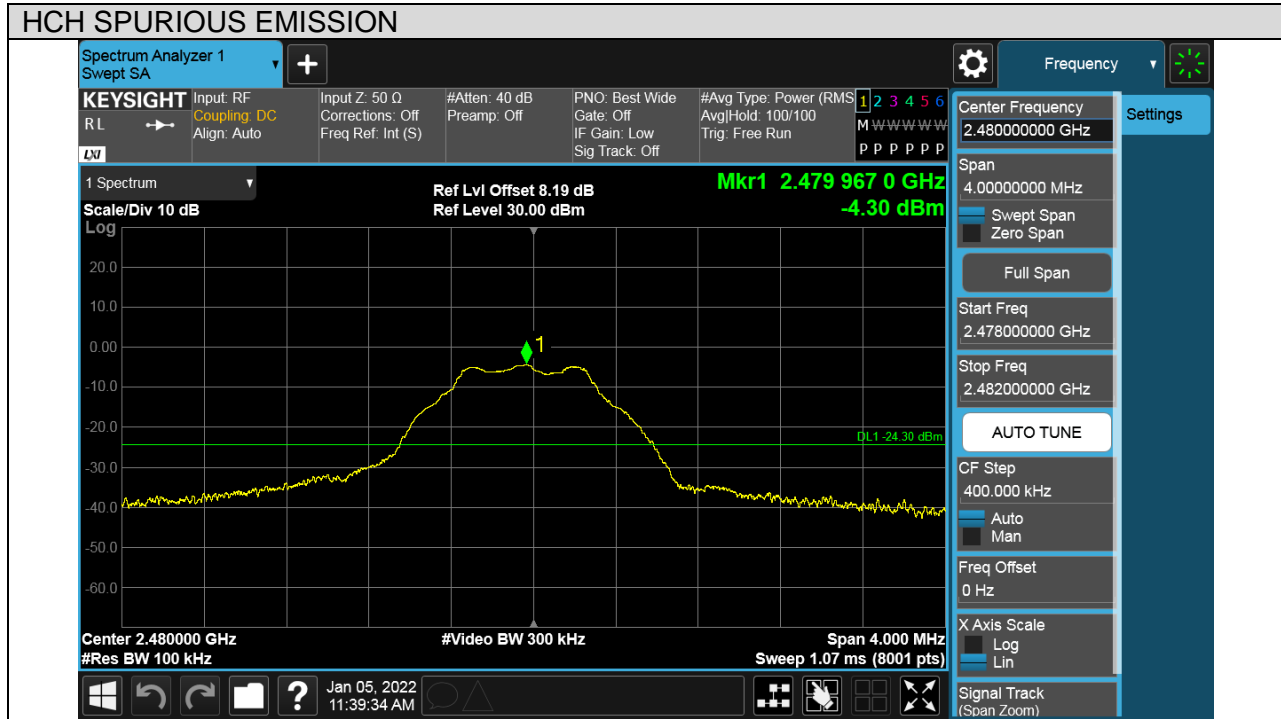

Puw test Plot

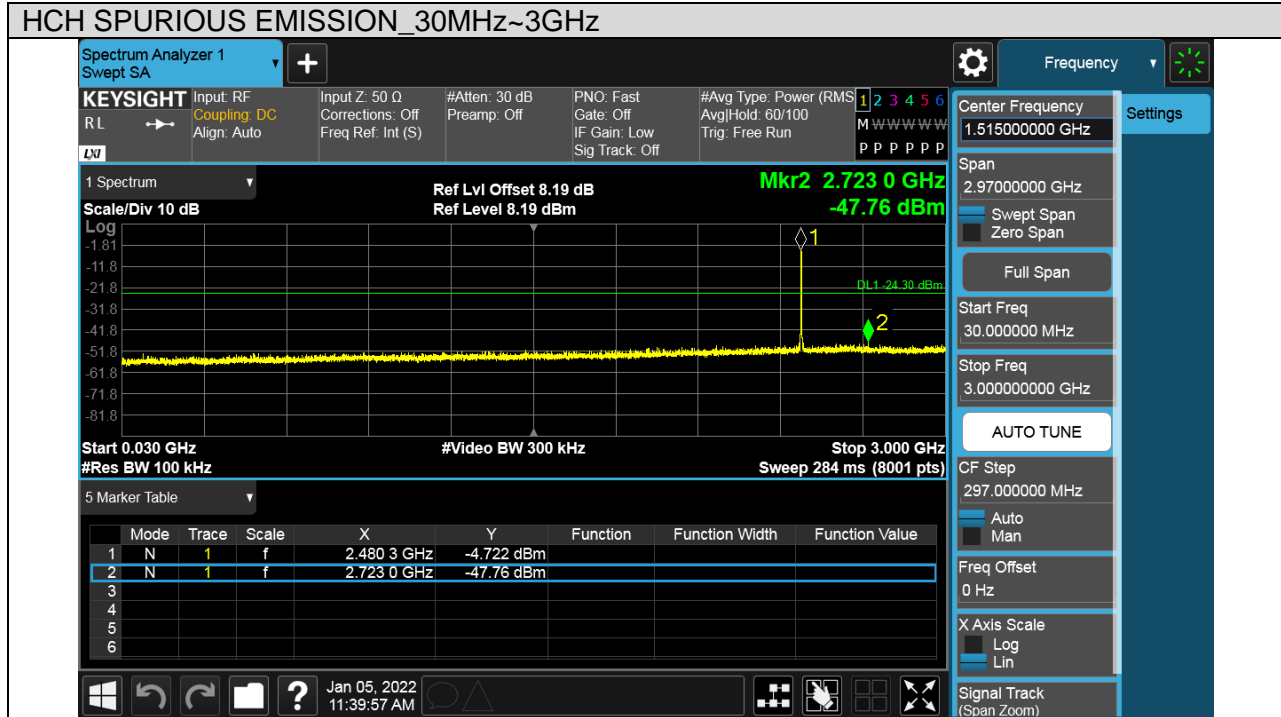

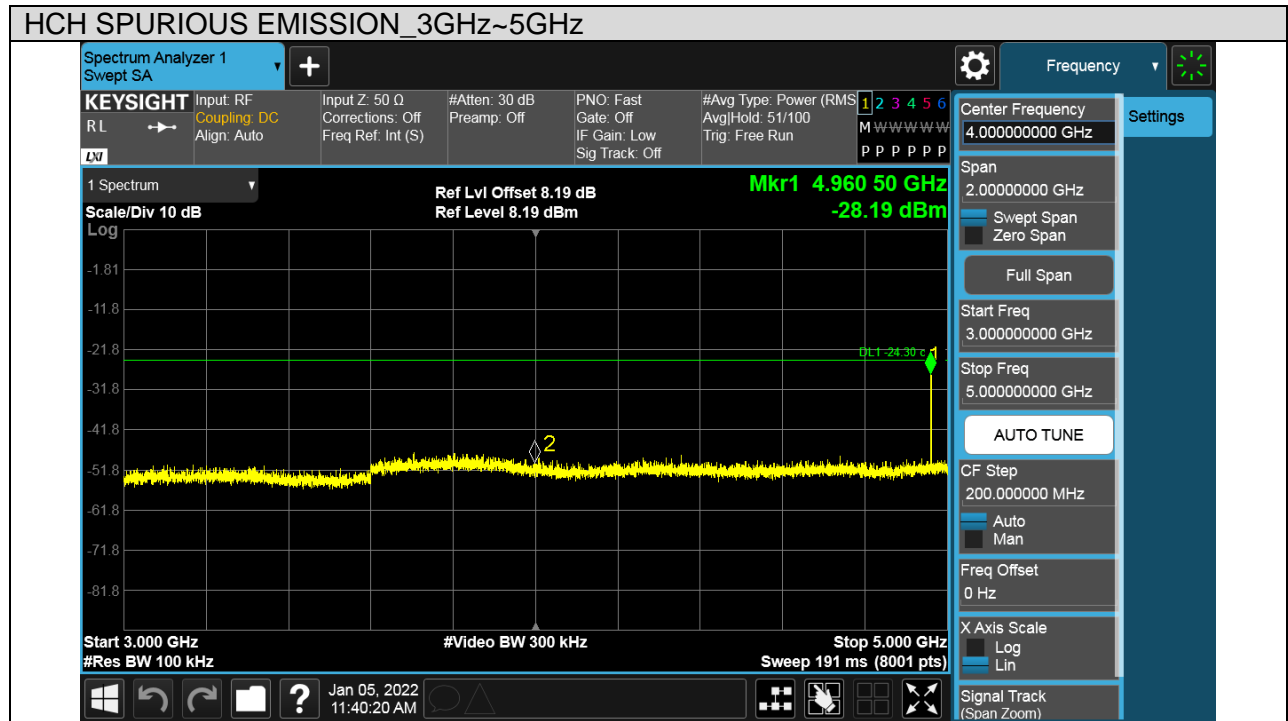

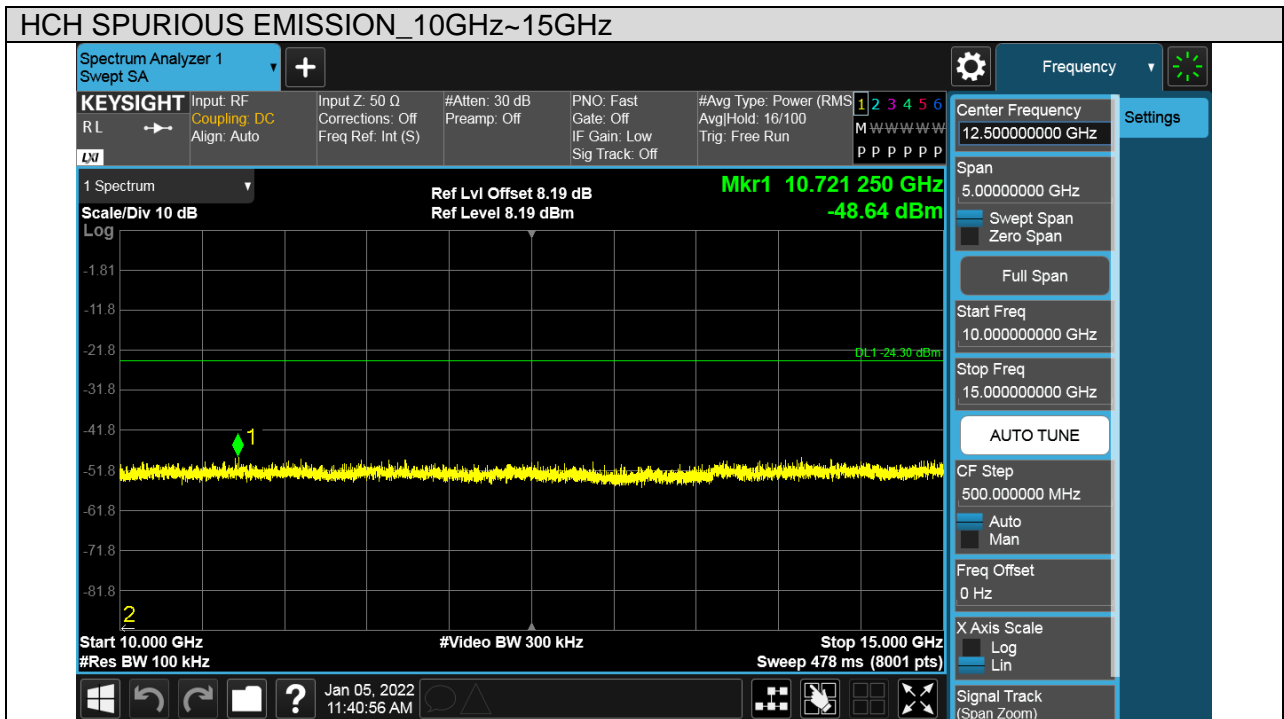
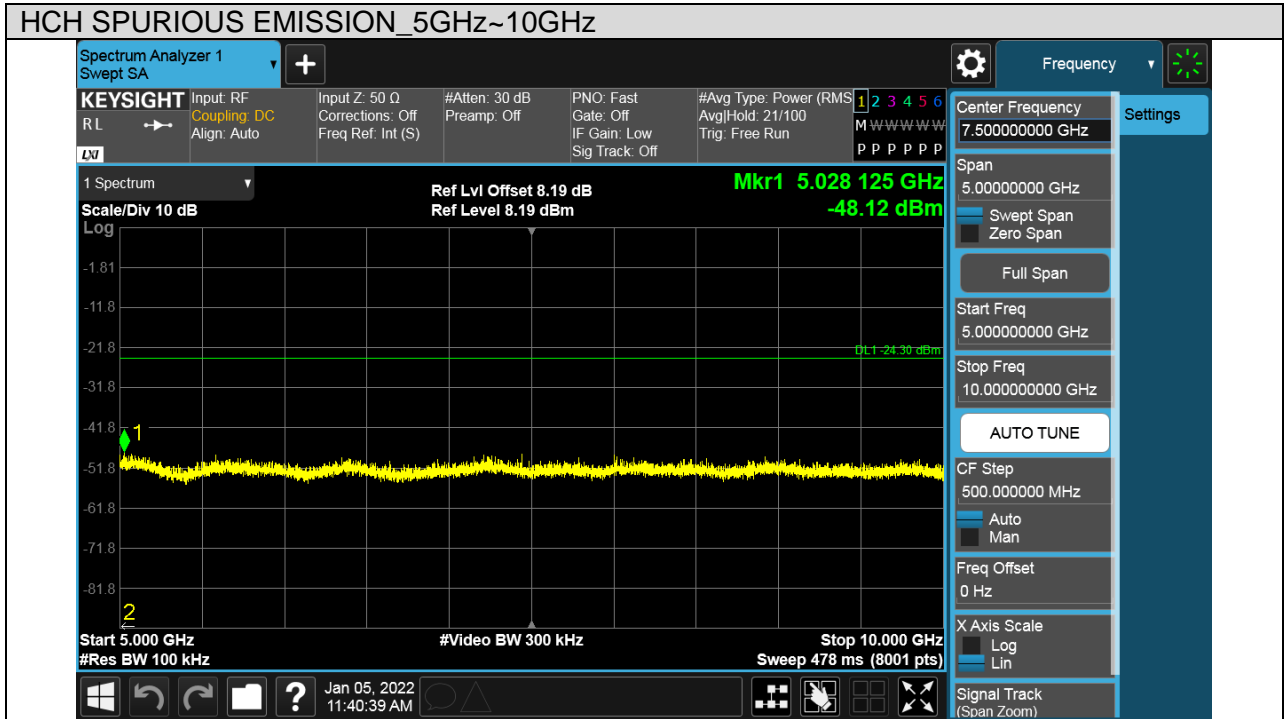

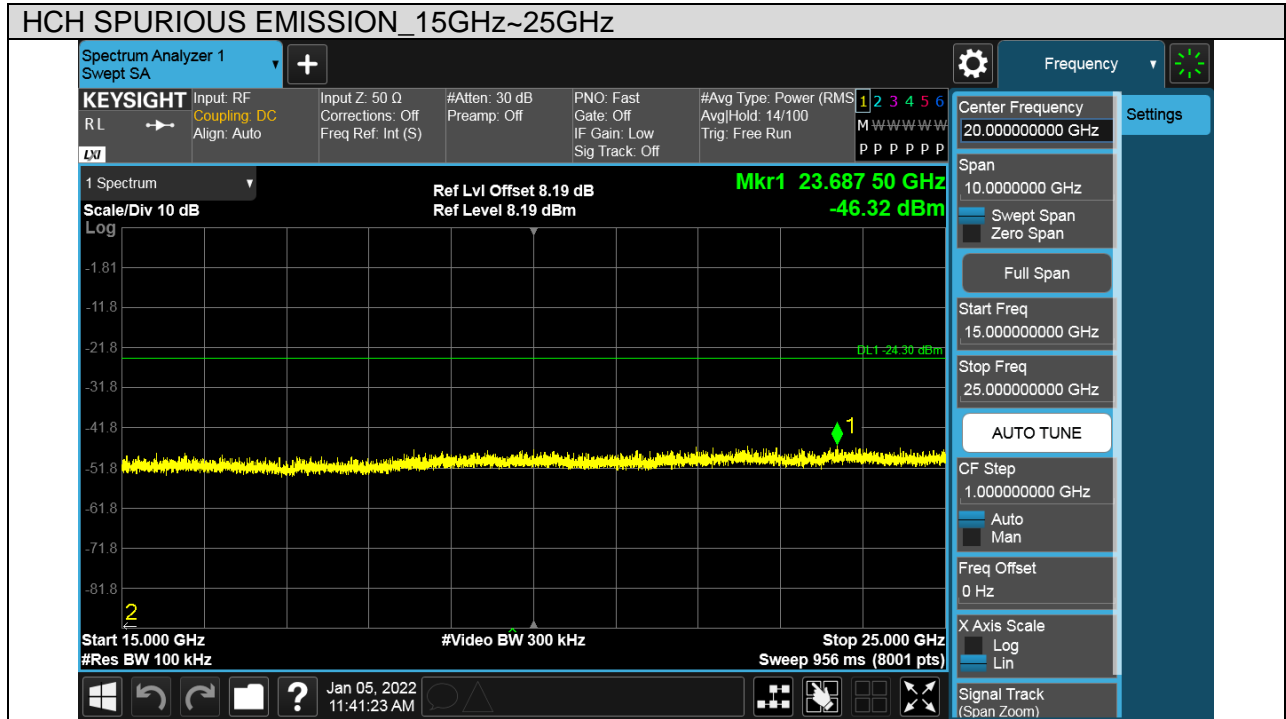



8. RADIATED TEST RESULTS

LIMITS

Please refer to CFR 47 FCC §15.205 and §15.209

Radiation Disturbance Test Limit for FCC (Class B)(9KHz-1GHz)

Frequency (MHz)	Field Strength (microvolts/meter)	Measurement Distance (meters)
0.009~0.490	2400/F(KHz)	300
0.490~1.705	24000/F(KHz)	30
1.705~30.0	30	30
30~88	100	3
88~216	150	3
216~960	200	3
960~1000	500	3

Note: 1) At frequencies at or above 30 MHz, measurements may be performed at a distance other than what is specified provided: measurements are not made in the near field except where it can be shown that near field measurements are appropriate due to the characteristics of the device; and it can be demonstrated that the signal levels needed to be measured at the distance employed can be detected by the measurement equipment. Measurements shall not be performed at a distance greater than 30 meters unless it can be further demonstrated that measurements at a distance of 30 meters or less are impractical. When performing measurements at a distance other than that specified, the results shall be extrapolated to the specified distance using an extrapolation factor of 20 dB/decade (inverse linear-distance for field strength measurements; inverse-linear-distance-squared for power density measurements).

(2) At frequencies below 30 MHz, measurements may be performed at a distance closer than that specified in the regulations; however, an attempt should be made to avoid making measurements in the near field. Pending the development of an appropriate measurement procedure for measurements performed below 30 MHz, when performing measurements at a closer distance than specified, the results shall be extrapolated to the specified distance by either making measurements at a minimum of two distances on at least one radial to determine the proper extrapolation factor or by using the square of an inverse linear distance extrapolation factor (40 dB/decade). This paragraph (f) shall not apply to Access BPL devices operating below 30 MHz.



Radiation Disturbance Test Limit for FCC (Above 1G)

Frequency (MHz)	dB(uV/m) (at 3 meters)	
	Peak	Average
Above 1000	74	54

FCC Restricted bands of operation:

MHz	MHz	MHz	GHz
0.090-0.110	16.42-16.423	399.9-410	4.5-5.15
¹ 0.495-0.505	16.69475-16.69525	608-614	5.35-5.46
2.1735-2.1905	16.80425-16.80475	960-1240	7.25-7.75
4.125-4.128	25.5-25.67	1300-1427	8.025-8.5
4.17725-4.17775	37.5-38.25	1435-1626.5	9.0-9.2
4.20725-4.20775	73-74.6	1645.5-1646.5	9.3-9.5
6.215-6.218	74.8-75.2	1660-1710	10.6-12.7
6.26775-6.26825	108-121.94	1718.8-1722.2	13.25-13.4
6.31175-6.31225	123-138	2200-2300	14.47-14.5
8.291-8.294	149.9-150.05	2310-2390	15.35-16.2
8.362-8.366	156.52475-156.52525	2483.5-2500	17.7-21.4
8.37625-8.38675	156.7-156.9	2690-2900	22.01-23.12
8.41425-8.41475	162.0125-167.17	3260-3267	23.6-24.0
12.29-12.293	167.72-173.2	3332-3339	31.2-31.8
12.51975-12.52025	240-285	3345.8-3358	36.43-36.5
12.57675-12.57725	322-335.4	3600-4400	(²)
13.36-13.41			

Note: ¹Until February 1, 1999, this restricted band shall be 0.490-0.510 MHz.
²Above 38.6c

TEST SETUP AND PROCEDURE

Below 30MHz

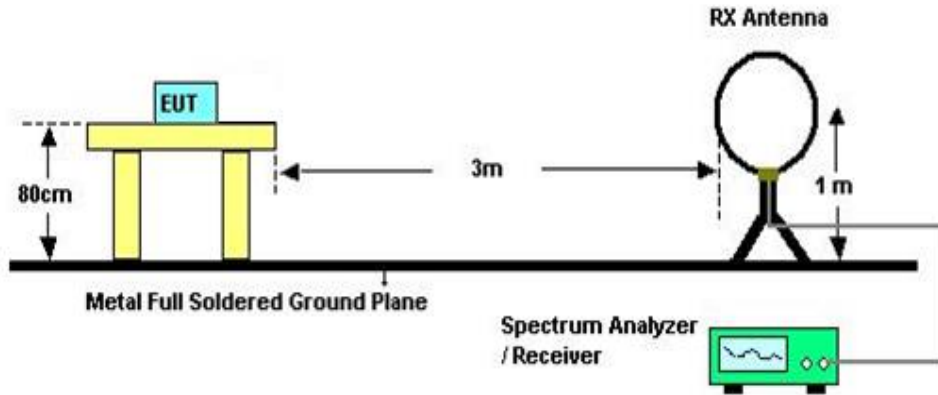

The setting of the spectrum analyser

RBW	200Hz (From 9kHz to 0.15MHz)/ 9KHz (From 0.15MHz to 30MHz)
VBW	200Hz (From 9kHz to 0.15MHz)/ 9KHz (From 0.15MHz to 30MHz)
Sweep	Auto
Detector	Peak/QP/ Average
Trace	Max hold

1. The testing follows the guidelines in ANSI C63.10-2013
2. The EUT was arranged to its worst case and then turntable (from 0 degree to 360 degrees) to find the maximum reading. A pre-amp and a high pass filter are used for the test in order to get better signal level. Both Horizontal, Face-on and Face-off polarizations of the antenna are set to make the measurement.
3. The EUT was placed on a turntable with 0.8 meter above ground.
4. The EUT was set 3 meters from the interference receiving antenna, which was mounted on the top of a 1m height antenna tower.
5. The radiated emission limits are based on measurements employing a CISPR quasi-peak detector except for the frequency bands 9-90 kHz, 110-490 kHz and above 1000 MHz. Radiated emission limits in these three bands are based on measurements employing an average detector
6. For measurement below 1GHz, the initial step in collecting conducted emission data is a spectrum analyzer peak detector mode pre-scanning the measurement frequency range. Significant peaks are then marked and then Quasi Peak detector mode re-measured. If the emission level of the EUT measured by the peak detector is 3 dB lower than the applicable limit, the peak emission level will be reported. Otherwise, the emission measurement will be repeated using the quasi-peak detector and reported.
7. For the actual test configuration, please refer to the related item in this test report
(Photographs of the Test Configuration)

Below 1G

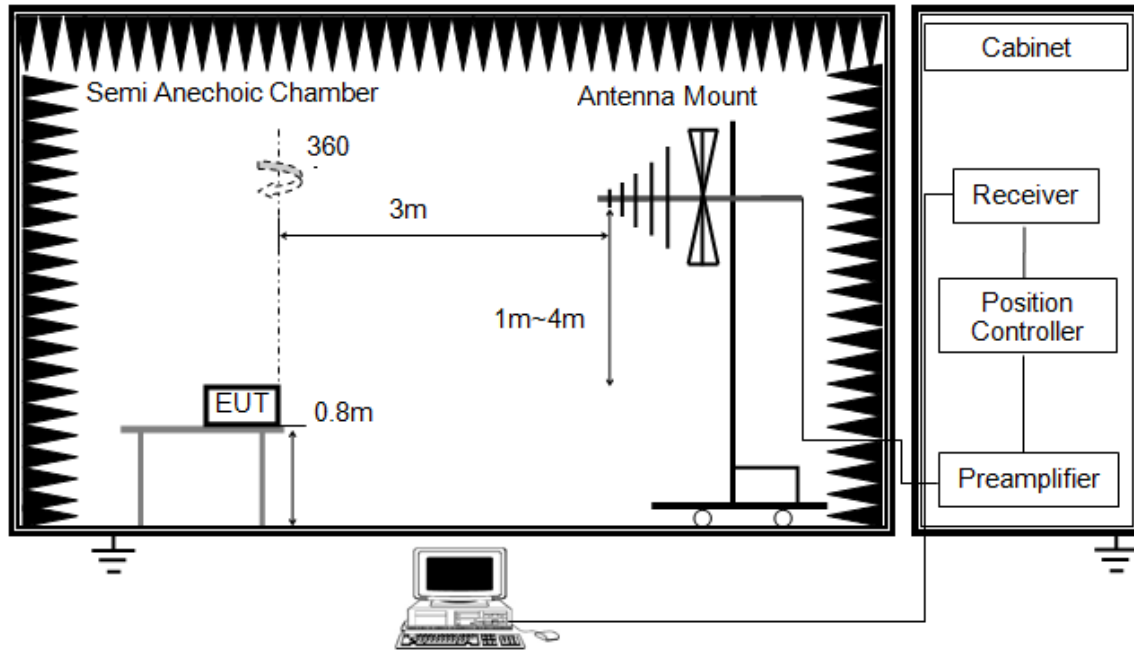

The setting of the spectrum analyser

RBW	120K
VBW	300K
Sweep	Auto
Detector	Peak/QP
Trace	Max hold

1. The testing follows the guidelines in ANSI C63.10-2013.
2. The EUT was arranged to its worst case and then tune the antenna tower (from 1 m to 4 m) and turntable (from 0 degree to 360 degrees) to find the maximum reading. A pre-amp and a high pass filter are used for the test in order to get better signal level. Both horizontal and vertical polarizations of the antenna are set to make the measurement.
3. The EUT was placed on a turntable with 0.8 meter above ground.
4. The EUT was set 3 meters from the interference receiving antenna, which was mounted on the top of a 1m height antenna tower.
5. For measurement below 1GHz, the initial step in collecting conducted emission data is a spectrum analyzer peak detector mode pre-scanning the measurement frequency range. Significant peaks are then marked and then Quasi Peak detector mode re-measured. If the emission level of the EUT measured by the peak detector is 3 dB lower than the applicable limit, the peak emission level will be reported. Otherwise, the emission measurement will be repeated using the quasi-peak detector and reported.
6. For the actual test configuration, please refer to the related item in this test report (Photographs of the Test Configuration)

Above 1G

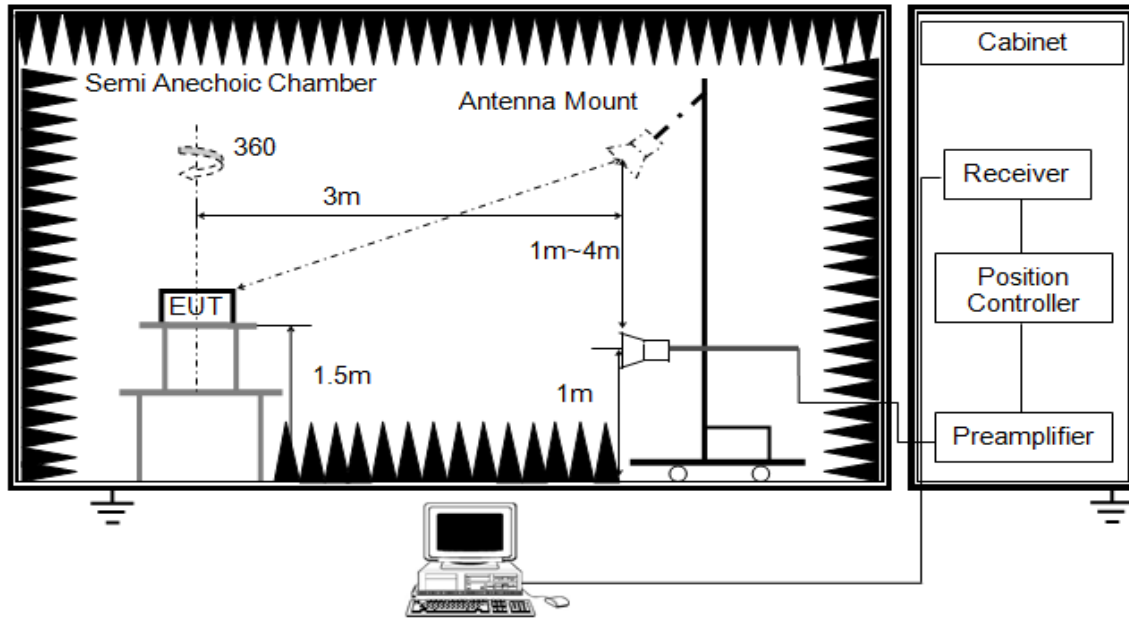

The setting of the spectrum analyser

RBW	1M
VBW	PEAK: 3M AVG: see note 6
Sweep	Auto
Detector	Peak
Trace	Max hold

1. The testing follows the guidelines in ANSI C63.10-2013.
2. The EUT was arranged to its worst case and then tune the antenna tower (from 1 m to 4 m) and turntable (from 0 degree to 360 degrees) to find the maximum reading. A pre-amp and a high pass filter are used for the test in order to get better signal level. Both horizontal and vertical polarizations of the antenna are set to make the measurement.
3. The EUT was placed on a turntable with 1.5m above ground.
4. The EUT was set 3 meters from the interference receiving antenna, which was mounted on the top of a variable height antenna tower.
5. For measurement above 1GHz, the emission measurement will be measured by the peak detector. This peak level, once corrected, must comply with the limit specified in Section 15.209.
6. For measurements above 1 GHz the resolution bandwidth is set to 1 MHz, then the video bandwidth is set to 3 MHz for peak measurements and 1 MHz resolution bandwidth with 1/T video bandwidth with peak detector for average measurements. For the Duty Cycle please refer to clause 8.1. ON TIME AND DUTY CYCLE.
7. For the actual test configuration, please refer to the related item in this test report
(Photographs of the Test Configuration)

X axis, Y axis, Z axis positions:

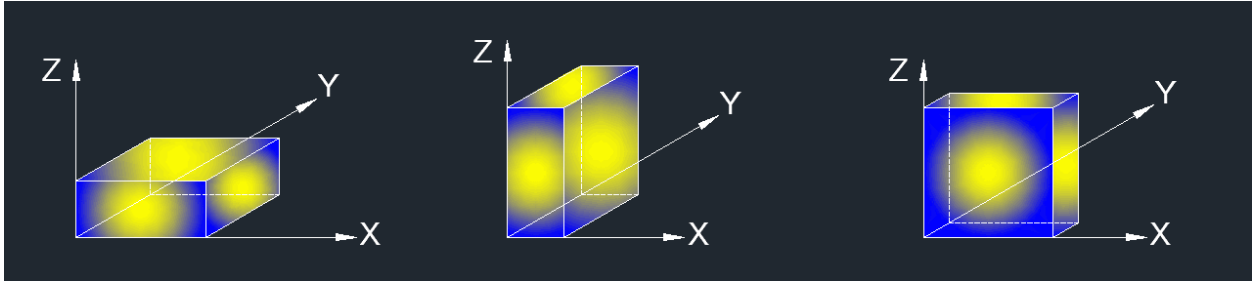

Note: For all radiated test, EUT in each of three orthogonal axis emissions had been tested, but only the worst case (X axis) data recorded in the report.

TEST ENVIRONMENT

Temperature	20°C	Relative Humidity	56%
Atmosphere Pressure	101kPa	Test Voltage	DC 24V



8.1. RESTRICTED BANDEDGE

Test Result Table

Test Mode	Channel	P _{uw} (dBm)	Verdict
BLE	CH00	<Limit	PASS
	CH39	<Limit	PASS



RESTRICTED BANDEDGE (CH00, HORIZONTAL)

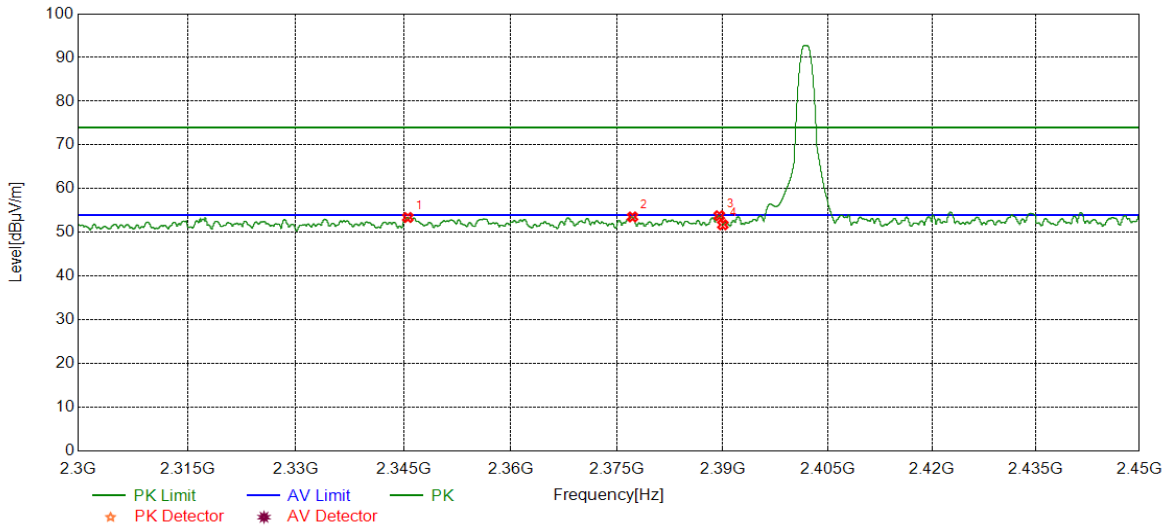

Peak Result:

No.	Frequency (MHz)	Reading Level (dBuV/m)	Correct Factor (dB)	Result (dBuV/m)	Limit (dBuV/m)	Margin (dB)	Remark
1	2345.5869	40.77	12.65	53.42	74.00	-20.58	peak
2	2377.1846	40.53	13.02	53.55	74.00	-20.45	peak
3	2389.5049	40.76	13.07	53.83	74.00	-20.17	peak
4	2390.0000	38.67	13.07	51.74	74.00	-22.26	peak

- Note:
1. Measurement = Reading Level + Correct Factor.
 2. If Peak Result complies with AV limit, AV Result is deemed to comply with AV limit.
 3. Peak: Peak detector.
 4. Only the worst case emission was recorded, if it complies with the limit, the other emissions deemed to comply with the limit.



RESTRICTED BANDEDGE (CH00, VERTICAL)

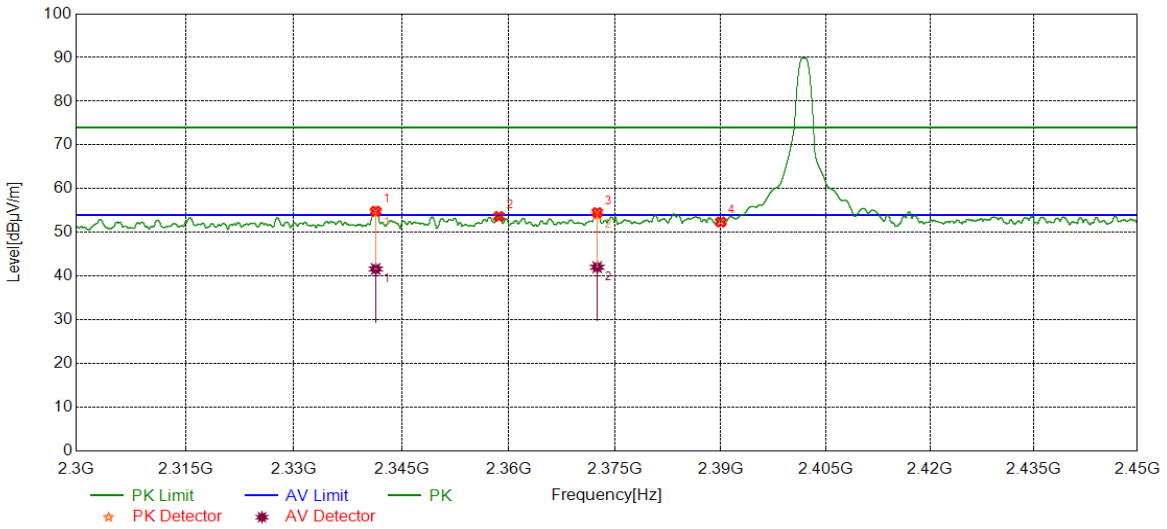

Peak Result:

No.	Frequency (MHz)	Reading Level (dBuV/m)	Correct Factor (dB)	Result (dBuV/m)	Limit (dBuV/m)	Margin (dB)	Remark
1	2341.3864	42.03	12.61	54.64	74.00	-19.36	peak
2	2358.6386	40.90	12.76	53.66	74.00	-20.34	peak
3	2372.4778	41.09	12.96	54.05	74.00	-19.95	peak
4	2390.0000	39.31	13.07	52.38	74.00	-21.62	peak

AV Result:

No.	Frequency (MHz)	Reading Level (dBuV/m)	Correct Factor (dB)	Result (dBuV/m)	Limit (dBuV/m)	Margin (dB)	Remark
1	2341.3864	29.03	12.61	41.64	54.00	-12.36	AV
2	2372.4778	29.09	12.96	42.05	54.00	-11.95	AV

- Note: 1. Measurement = Reading Level + Correct Factor.
 2. If Peak Result complies with AV limit, AV Result is deemed to comply with AV limit.
 3. Peak: Peak detector.
 4. Only the worst case emission was recorded, if it complies with the limit, the other emissions deemed to comply with the limit.



RESTRICTED BANDEDGE (CH39, HORIZONTAL)

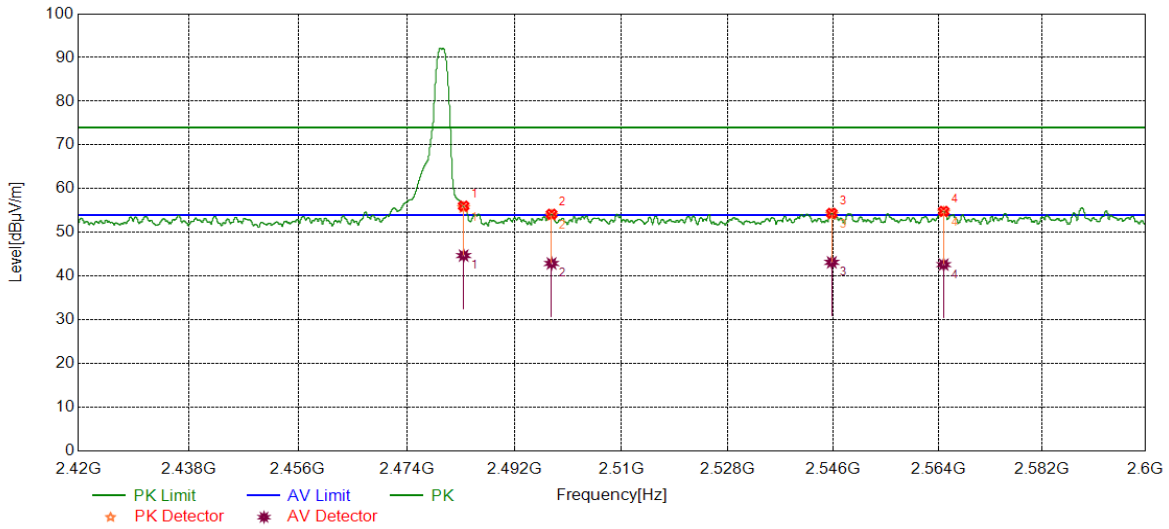

Peak Result:

No.	Frequency (MHz)	Reading Level (dBuV/m)	Correct Factor (dB)	Result (dBuV/m)	Limit (dBuV/m)	Margin (dB)	Remark
1	2483.5000	42.74	12.97	55.71	74.00	-18.29	peak
2	2498.2198	40.81	13.11	53.92	74.00	-20.08	peak
3	2545.7232	40.78	13.38	54.16	74.00	-19.84	peak
4	2564.9406	41.21	13.43	54.64	74.00	-19.36	peak

AV Result:

No.	Frequency (MHz)	Reading Level (dBuV/m)	Correct Factor (dB)	Result (dBuV/m)	Limit (dBuV/m)	Margin (dB)	Remark
1	2483.5000	31.74	12.97	44.71	54.00	-9.29	AV
2	2498.2198	29.80	13.11	42.91	54.00	-11.09	AV
3	2545.7232	29.78	13.38	43.16	54.00	-10.84	AV
4	2564.9406	29.21	13.43	42.64	54.00	-11.36	AV

- Note: 1. Measurement = Reading Level + Correct Factor.
 2. If Peak Result complies with AV limit, AV Result is deemed to comply with AV limit.
 3. Peak: Peak detector.
 4. Only the worst case emission was recorded, if it complies with the limit, the other emissions deemed to comply with the limit.



RESTRICTED BANDEDGE (CH39, VERTICAL)

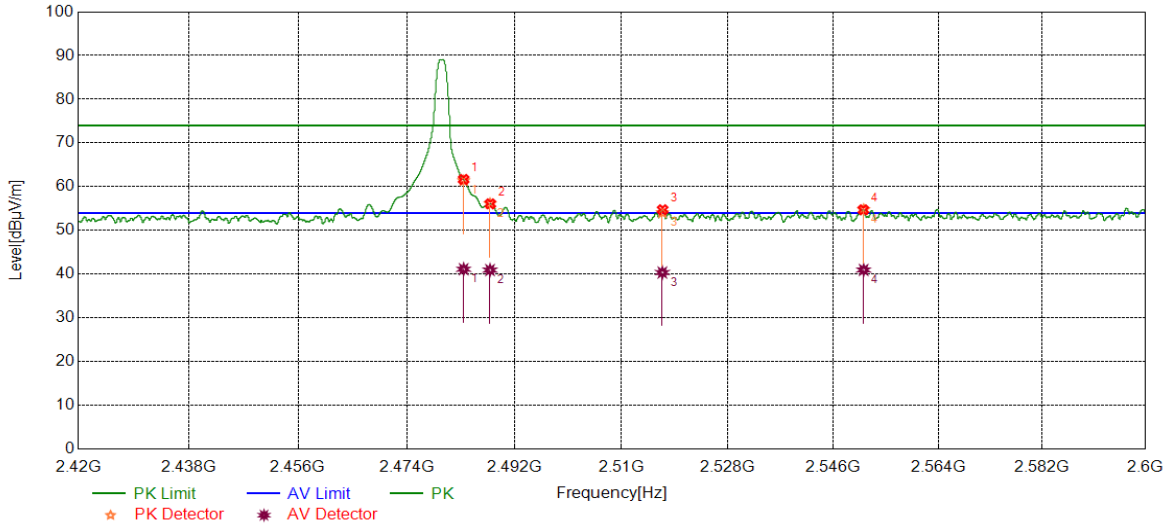

Peak Result:

No.	Frequency (MHz)	Reading Level (dBuV/m)	Correct Factor (dB)	Result (dBuV/m)	Limit (dBuV/m)	Margin (dB)	Remark
1	2483.5000	48.41	12.97	61.38	74.00	-12.62	peak
2	2487.9086	43.16	12.98	56.14	74.00	-17.86	peak
3	2516.8922	40.86	13.22	54.08	74.00	-19.92	peak
4	2551.1738	41.40	13.36	54.76	74.00	-19.24	peak

AV Result:

No.	Frequency (MHz)	Reading Level (dBuV/m)	Correct Factor (dB)	Result (dBuV/m)	Limit (dBuV/m)	Margin (dB)	Remark
1	2483.5000	28.16	12.97	41.13	54.00	-12.87	AV
2	2487.9086	27.95	12.98	40.93	54.00	-13.07	AV
3	2516.8922	27.15	13.22	40.37	54.00	-13.63	AV
4	2551.1738	27.60	13.36	40.96	54.00	-13.04	AV

- Note: 1. Measurement = Reading Level + Correct Factor.
 2. If Peak Result complies with AV limit, AV Result is deemed to comply with AV limit.
 3. Peak: Peak detector.
 4. Only the worst case emission was recorded, if it complies with the limit, the other emissions deemed to comply with the limit.

8.2. SPURIOUS EMISSIONS (1-3GHz)

HARMONICS AND SPURIOUS EMISSIONS (CH00, HORIZONTAL)

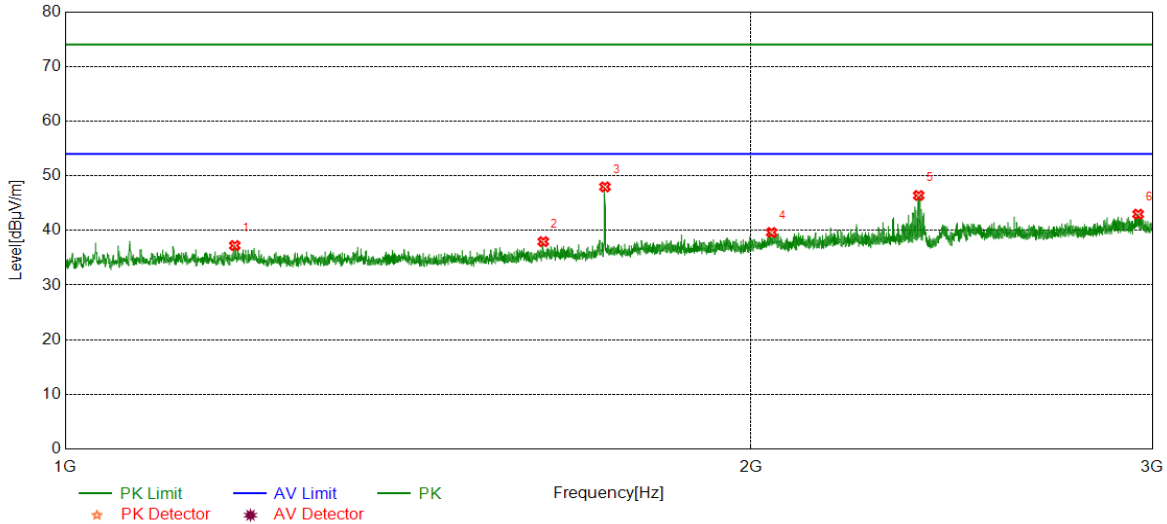

Peak Result:

No.	Frequency (MHz)	Reading Level (dBuV/m)	Correct Factor (dB)	Result (dBuV/m)	Limit (dBuV/m)	Margin (dB)	Remark
1	1187.0000	42.83	-5.60	37.23	74.00	-36.77	peak
2	1621.2500	42.97	-5.02	37.95	74.00	-36.05	peak
3	1725.5000	52.34	-4.37	47.97	74.00	-26.03	peak
4	2042.0000	42.02	-2.39	39.63	74.00	-34.37	peak
5	2369.2500	47.54	-1.14	46.40	74.00	-27.60	peak
6	2957.5000	42.05	0.93	42.98	74.00	-31.02	peak

- Note:
1. Measurement = Reading Level + Correct Factor.
 2. If Peak Result complies with AV limit, AV Result is deemed to comply with AV limit.
 3. Peak: Peak detector.
 4. For below 3GHz part, Filter losses were only considered in the spurious frequency bands and the authorized band was not corrected for Band Reject Filter losses.
 5. For above 3GHz part, Filter losses were only considered in the spurious frequency bands and the authorized band was not corrected for HPF losses.
 6. Proper operation of the transmitter prior to adding the filter to the measurement chain.
 7. Only the worst case emission was recorded, if it complies with the limit, the other emissions deemed to comply with the limit.

HARMONICS AND SPURIOUS EMISSIONS (CH00, VERTICAL)

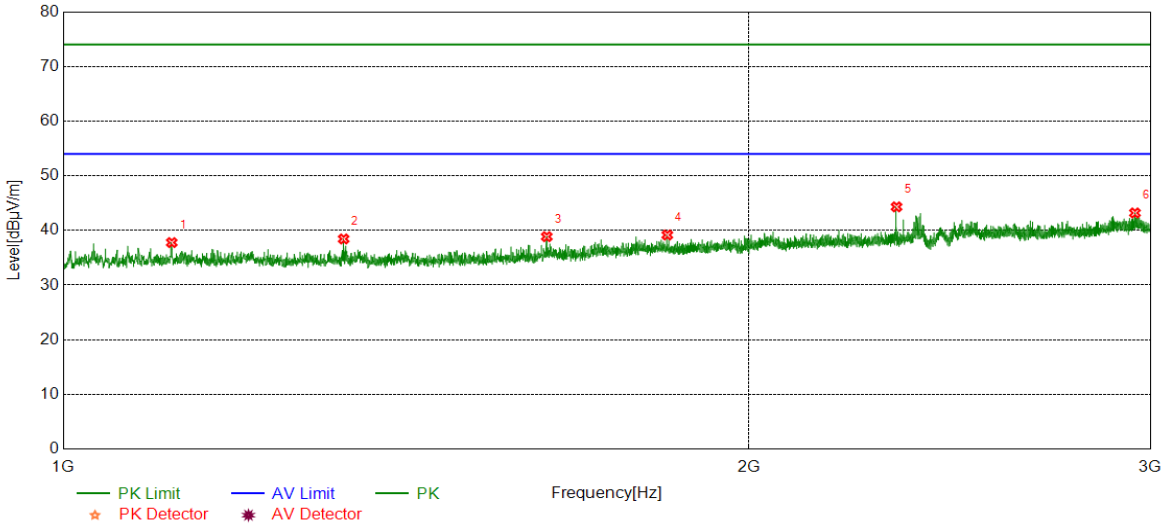

Peak Result:

No.	Frequency (MHz)	Reading Level (dBuV/m)	Correct Factor (dB)	Result (dBuV/m)	Limit (dBuV/m)	Margin (dB)	Remark
1	1116.0000	43.27	-5.49	37.78	74.00	-36.22	peak
2	1327.7500	44.10	-5.66	38.44	74.00	-35.56	peak
3	1630.2500	43.93	-5.07	38.86	74.00	-35.14	peak
4	1841.5000	42.88	-3.71	39.17	74.00	-34.83	peak
5	2321.5000	45.99	-1.68	44.31	74.00	-29.69	peak
6	2954.0000	42.35	0.85	43.20	74.00	-30.80	peak

- Note: 1. Measurement = Reading Level + Correct Factor.
 2. If Peak Result complies with AV limit, AV Result is deemed to comply with AV limit.
 3. Peak: Peak detector.
 4. For below 3GHz part, Filter losses were only considered in the spurious frequency bands and the authorized band was not corrected for Band Reject Filter losses.
 5. For above 3GHz part, Filter losses were only considered in the spurious frequency bands and the authorized band was not corrected for HPF losses.
 6. Proper operation of the transmitter prior to adding the filter to the measurement chain.
 7. Only the worst case emission was recorded, if it complies with the limit, the other emissions deemed to comply with the limit.

HARMONICS AND SPURIOUS EMISSIONS (CH19, HORIZONTAL)

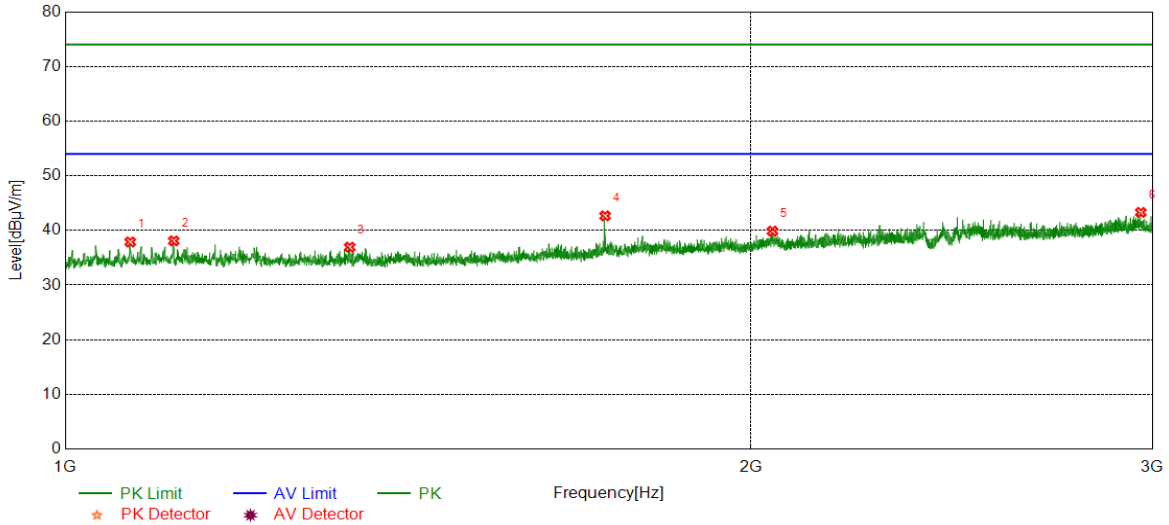

Peak Result:

No.	Frequency (MHz)	Reading Level (dBuV/m)	Correct Factor (dB)	Result (dBuV/m)	Limit (dBuV/m)	Margin (dB)	Remark
1	1068.0000	43.20	-5.32	37.88	74.00	-36.12	peak
2	1116.0000	43.58	-5.49	38.09	74.00	-35.91	peak
3	1333.2500	42.61	-5.67	36.94	74.00	-37.06	peak
4	1725.7500	47.04	-4.38	42.66	74.00	-31.34	peak
5	2043.7500	42.27	-2.39	39.88	74.00	-34.12	peak
6	2965.5000	42.25	1.05	43.30	74.00	-30.70	peak

- Note:
1. Measurement = Reading Level + Correct Factor.
 2. If Peak Result complies with AV limit, AV Result is deemed to comply with AV limit.
 3. Peak: Peak detector.
 4. For below 3GHz part, Filter losses were only considered in the spurious frequency bands and the authorized band was not corrected for Band Reject Filter losses.
 5. For above 3GHz part, Filter losses were only considered in the spurious frequency bands and the authorized band was not corrected for HPF losses.
 6. Proper operation of the transmitter prior to adding the filter to the measurement chain.
 7. Only the worst case emission was recorded, if it complies with the limit, the other emissions deemed to comply with the limit.

HARMONICS AND SPURIOUS EMISSIONS (CH19, VERTICAL)

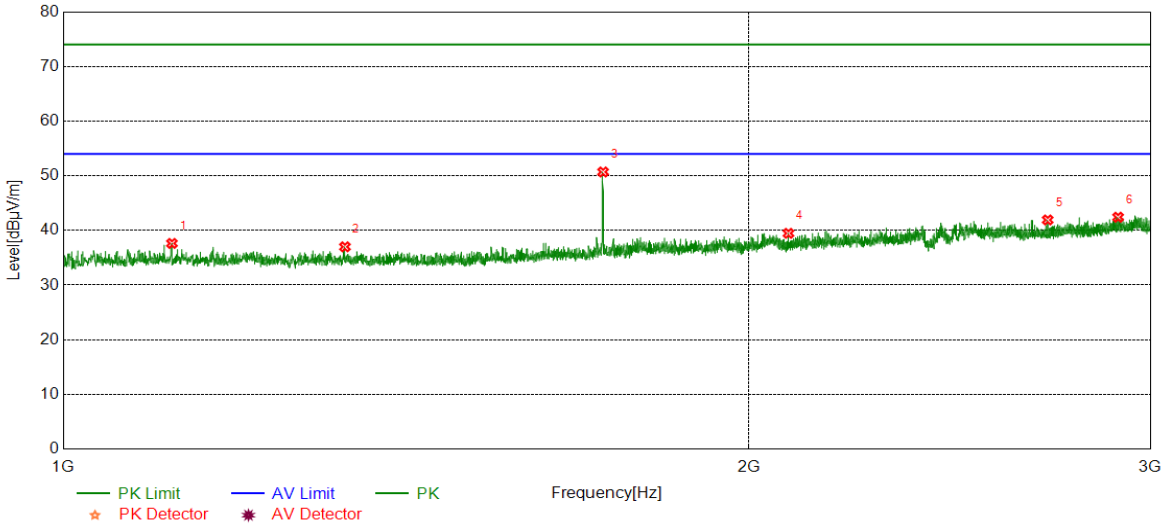

Peak Result:

No.	Frequency (MHz)	Reading Level (dBuV/m)	Correct Factor (dB)	Result (dBuV/m)	Limit (dBuV/m)	Margin (dB)	Remark
1	1116.2500	43.12	-5.49	37.63	74.00	-36.37	peak
2	1329.5000	42.68	-5.68	37.00	74.00	-37.00	peak
3	1725.7500	55.08	-4.38	50.70	74.00	-23.30	peak
4	2081.2500	42.17	-2.70	39.47	74.00	-34.53	peak
5	2704.7500	42.26	-0.34	41.92	74.00	-32.08	peak
6	2904.0000	42.05	0.37	42.42	74.00	-31.58	peak

- Note:
1. Measurement = Reading Level + Correct Factor.
 2. If Peak Result complies with AV limit, AV Result is deemed to comply with AV limit.
 3. Peak: Peak detector.
 4. For below 3GHz part, Filter losses were only considered in the spurious frequency bands and the authorized band was not corrected for Band Reject Filter losses.
 5. For above 3GHz part, Filter losses were only considered in the spurious frequency bands and the authorized band was not corrected for HPF losses.
 6. Proper operation of the transmitter prior to adding the filter to the measurement chain.
 7. Only the worst case emission was recorded, if it complies with the limit, the other emissions deemed to comply with the limit.



HARMONICS AND SPURIOUS EMISSIONS (CH39, HORIZONTAL)

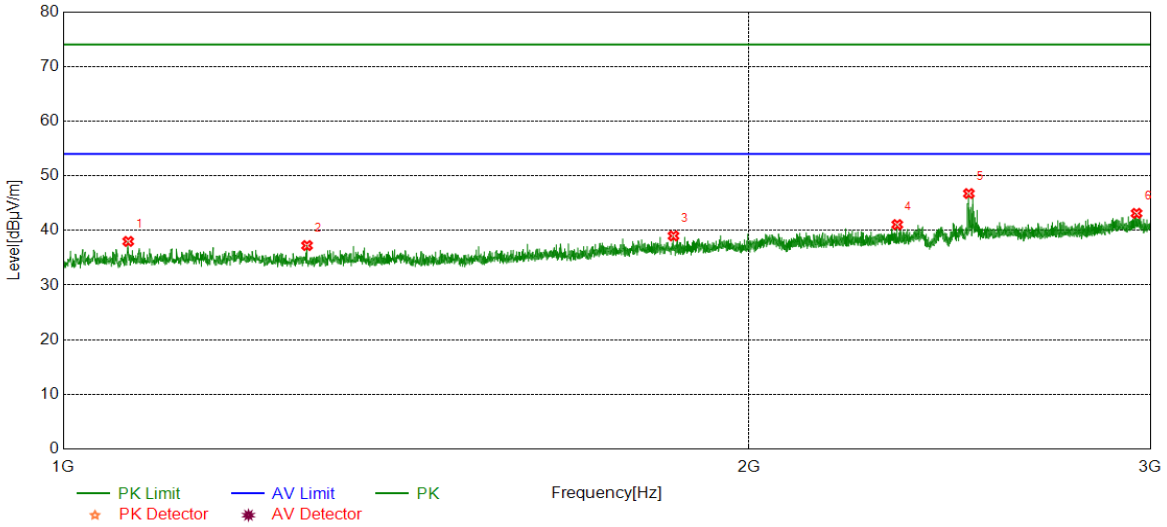

Peak Result:

No.	Frequency (MHz)	Reading Level (dBuV/m)	Correct Factor (dB)	Result (dBuV/m)	Limit (dBuV/m)	Margin (dB)	Remark
1	1068.0000	43.31	-5.32	37.99	74.00	-36.01	peak
2	1279.5000	42.84	-5.61	37.23	74.00	-36.77	peak
3	1853.0000	42.69	-3.69	39.00	74.00	-35.00	peak
4	2323.2500	42.78	-1.71	41.07	74.00	-32.93	peak
5	2497.5000	47.21	-0.46	46.75	74.00	-27.25	peak
6	2958.7500	42.17	0.96	43.13	74.00	-30.87	peak

- Note:
1. Measurement = Reading Level + Correct Factor.
 2. If Peak Result complies with AV limit, AV Result is deemed to comply with AV limit.
 3. Peak: Peak detector.
 4. For below 3GHz part, Filter losses were only considered in the spurious frequency bands and the authorized band was not corrected for Band Reject Filter losses.
 5. For above 3GHz part, Filter losses were only considered in the spurious frequency bands and the authorized band was not corrected for HPF losses.
 6. Proper operation of the transmitter prior to adding the filter to the measurement chain.
 7. Only the worst case emission was recorded, if it complies with the limit, the other emissions deemed to comply with the limit.

HARMONICS AND SPURIOUS EMISSIONS (CH39, VERTICAL)

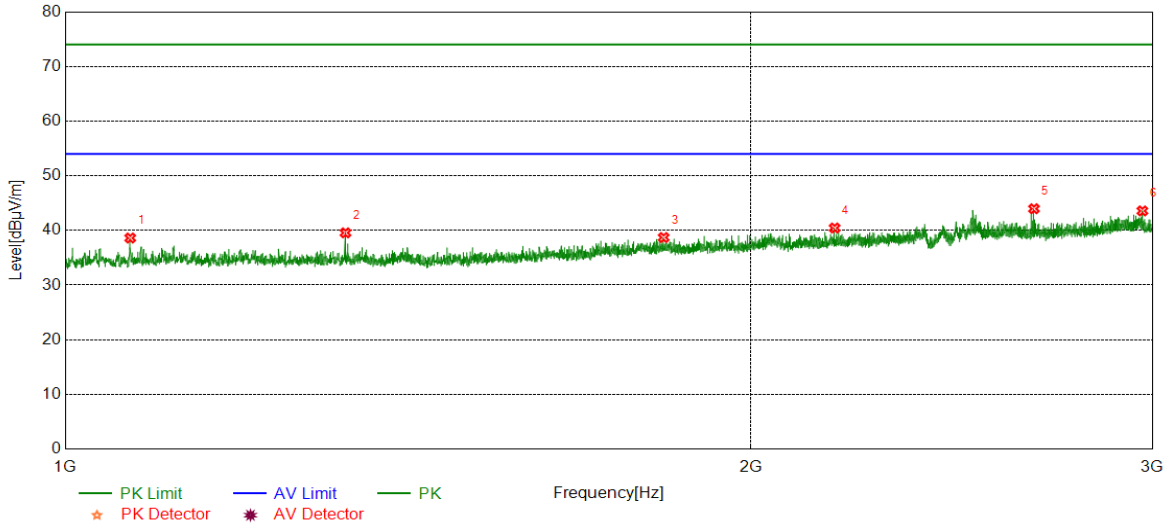

Peak Result:

No.	Frequency (MHz)	Reading Level (dBuV/m)	Correct Factor (dB)	Result (dBuV/m)	Limit (dBuV/m)	Margin (dB)	Remark
1	1068.0000	43.93	-5.32	38.61	74.00	-35.39	peak
2	1327.5000	45.22	-5.66	39.56	74.00	-34.44	peak
3	1831.0000	42.39	-3.69	38.70	74.00	-35.30	peak
4	2176.2500	42.77	-2.33	40.44	74.00	-33.56	peak
5	2662.0000	44.65	-0.68	43.97	74.00	-30.03	peak
6	2970.2500	42.48	1.09	43.57	74.00	-30.43	peak

- Note:
1. Measurement = Reading Level + Correct Factor.
 2. If Peak Result complies with AV limit, AV Result is deemed to comply with AV limit.
 3. Peak: Peak detector.
 4. For below 3GHz part, Filter losses were only considered in the spurious frequency bands and the authorized band was not corrected for Band Reject Filter losses.
 5. For above 3GHz part, Filter losses were only considered in the spurious frequency bands and the authorized band was not corrected for HPF losses.
 6. Proper operation of the transmitter prior to adding the filter to the measurement chain.
 7. Only the worst case emission was recorded, if it complies with the limit, the other emissions deemed to comply with the limit.

8.3. SPURIOUS EMISSIONS (3-18GHz)

HARMONICS AND SPURIOUS EMISSIONS (CH00, HORIZONTAL)

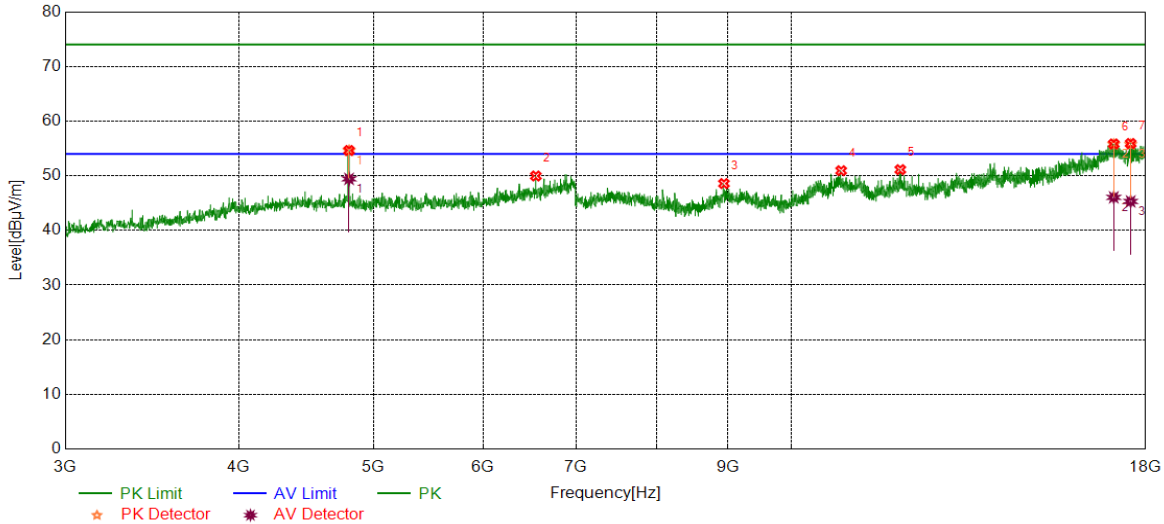

Peak Result:

No.	Frequency (MHz)	Reading Level (dBuV/m)	Correct Factor (dB)	Result (dBuV/m)	Limit (dBuV/m)	Margin (dB)	Remark
1	4803.9755	49.1	5.49	54.59	74.00	-19.41	peak
2	6547.9435	42.36	7.60	49.96	74.00	-24.04	peak
3	8944.4931	39.64	8.94	48.58	74.00	-25.42	peak
4	10862.8579	38.76	12.17	50.93	74.00	-23.07	peak
5	11982.3728	38.29	12.83	51.12	74.00	-22.88	peak
6	17071.7590	36.62	19.11	55.73	74.00	-18.27	peak
7	17557.4447	37.76	17.94	55.70	74.00	-18.30	peak

AV Result:

No.	Frequency (MHz)	Reading Level (dBuV/m)	Correct Factor (dB)	Result (dBuV/m)	Limit (dBuV/m)	Margin (dB)	Remark
1	4803.9755	43.94	5.49	49.43	54.00	-4.57	peak
2	17071.7590	26.94	19.11	46.05	54.00	-7.95	peak
3	17557.4447	27.37	17.94	45.31	54.00	-8.69	peak

- Note:
1. Measurement = Reading Level + Correct Factor.
 2. If Peak Result complies with AV limit, AV Result is deemed to comply with AV limit.
 3. Peak: Peak detector.
 4. For below 3GHz part, Filter losses were only considered in the spurious frequency bands and the authorized band was not corrected for Band Reject Filter losses.
 5. For above 3GHz part, Filter losses were only considered in the spurious frequency bands and the authorized band was not corrected for HPF losses.
 6. Proper operation of the transmitter prior to adding the filter to the measurement chain.
 7. Only the worst case emission was recorded, if it complies with the limit, the other emissions deemed to comply with the limit.



HARMONICS AND SPURIOUS EMISSIONS (CH00, VERTICAL)

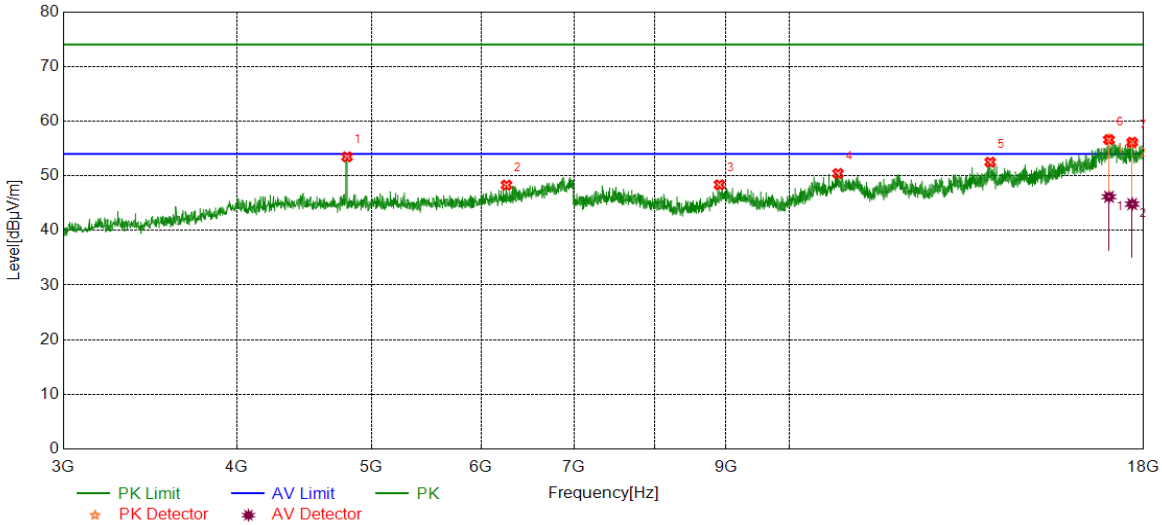

Peak Result:

No.	Frequency (MHz)	Reading Level (dBuV/m)	Correct Factor (dB)	Result (dBuV/m)	Limit (dBuV/m)	Margin (dB)	Remark
1	4803.9755	47.98	5.49	53.47	74.00	-20.53	peak
2	6257.2822	42.09	6.20	48.29	74.00	-25.71	peak
3	8906.9884	39.83	8.52	48.35	74.00	-25.65	peak
4	10842.2303	38.20	12.21	50.41	74.00	-23.59	peak
5	13955.1194	38.43	14.06	52.49	74.00	-21.51	peak
6	16992.9991	37.97	18.72	56.69	74.00	-17.31	peak
7	17660.5826	38.58	17.29	55.87	74.00	-18.13	peak

AV Result:

No.	Frequency (MHz)	Reading Level (dBuV/m)	Correct Factor (dB)	Result (dBuV/m)	Limit (dBuV/m)	Margin (dB)	Remark
1	16992.9991	27.44	18.72	46.16	54.00	-7.84	peak
2	17660.5826	27.53	17.29	44.82	54.00	-9.18	peak

- Note:
1. Measurement = Reading Level + Correct Factor.
 2. If Peak Result complies with AV limit, AV Result is deemed to comply with AV limit.
 3. Peak: Peak detector.
 4. For below 3GHz part, Filter losses were only considered in the spurious frequency bands and the authorized band was not corrected for Band Reject Filter losses.
 5. For above 3GHz part, Filter losses were only considered in the spurious frequency bands and the authorized band was not corrected for HPF losses.
 6. Proper operation of the transmitter prior to adding the filter to the measurement chain.
 7. Only the worst case emission was recorded, if it complies with the limit, the other emissions deemed to comply with the limit.

HARMONICS AND SPURIOUS EMISSIONS (CH19, HORIZONTAL)

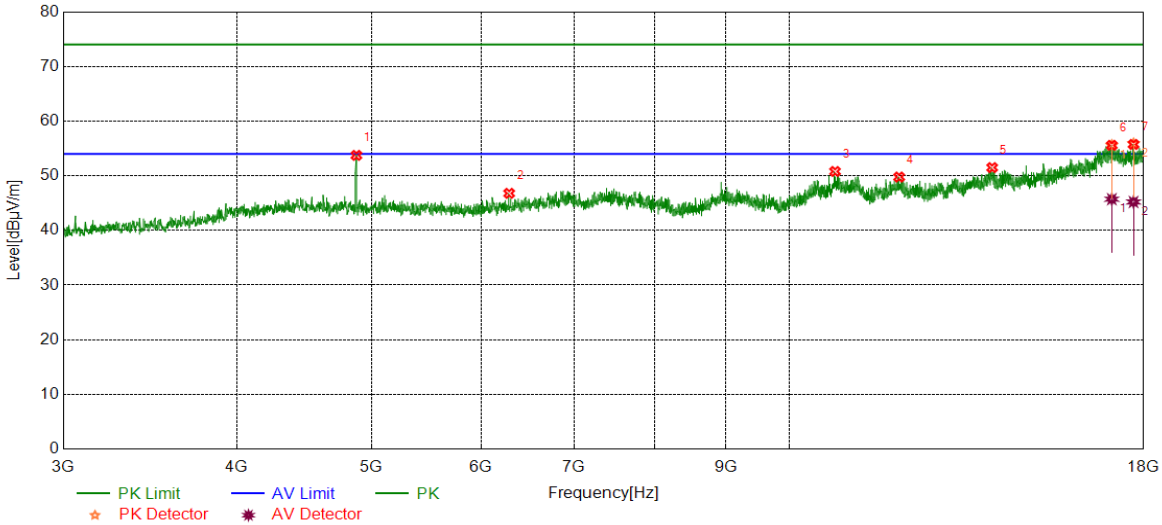

Peak Result:

No.	Frequency (MHz)	Reading Level (dBuV/m)	Correct Factor (dB)	Result (dBuV/m)	Limit (dBuV/m)	Margin (dB)	Remark
1	4878.9849	48.41	5.33	53.74	74.00	-20.26	peak
2	6285.4107	40.54	6.25	46.79	74.00	-27.21	peak
3	10789.7237	38.69	12.10	50.79	74.00	-23.21	peak
4	11999.2499	36.80	12.97	49.77	74.00	-24.23	peak
5	14000.1250	37.14	14.36	51.50	74.00	-22.50	peak
6	17073.6342	36.54	19.02	55.56	74.00	-18.44	peak
7	17699.9625	38.11	17.76	55.87	74.00	-18.13	peak

AV Result:

No.	Frequency (MHz)	Reading Level (dBuV/m)	Correct Factor (dB)	Result (dBuV/m)	Limit (dBuV/m)	Margin (dB)	Remark
1	17073.6342	26.70	19.02	45.72	54.00	-8.28	peak
2	17699.9625	27.45	17.76	45.21	54.00	-8.79	peak

- Note:
1. Measurement = Reading Level + Correct Factor.
 2. If Peak Result complies with AV limit, AV Result is deemed to comply with AV limit.
 3. Peak: Peak detector.
 4. For below 3GHz part, Filter losses were only considered in the spurious frequency bands and the authorized band was not corrected for Band Reject Filter losses.
 5. For above 3GHz part, Filter losses were only considered in the spurious frequency bands and the authorized band was not corrected for HPF losses.
 6. Proper operation of the transmitter prior to adding the filter to the measurement chain.
 7. Only the worst case emission was recorded, if it complies with the limit, the other emissions deemed to comply with the limit.

HARMONICS AND SPURIOUS EMISSIONS (CH19, VERTICAL)

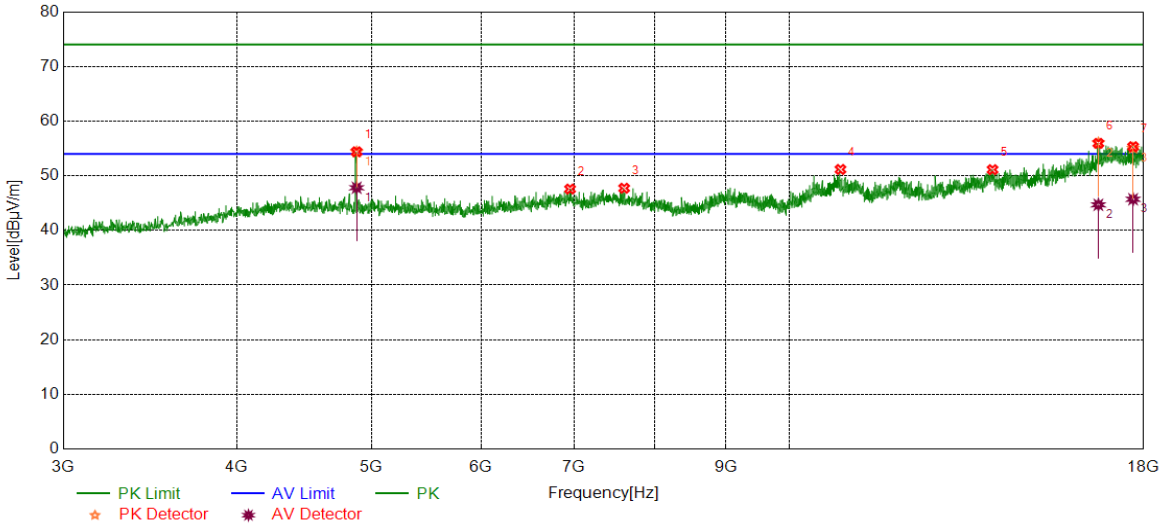

Peak Result:

No.	Frequency (MHz)	Reading Level (dBuV/m)	Correct Factor (dB)	Result (dBuV/m)	Limit (dBuV/m)	Margin (dB)	Remark
1	4880.8601	49.05	5.33	54.38	74.00	-19.62	peak
2	6952.9941	38.98	8.59	47.57	74.00	-26.43	peak
3	7605.5757	39.07	8.65	47.72	74.00	-26.28	peak
4	10887.2359	38.92	12.24	51.16	74.00	-22.84	peak
5	14009.5012	36.80	14.32	51.12	74.00	-22.88	peak
6	16696.7121	38.02	18.00	56.02	74.00	-17.98	peak
7	17686.8359	37.1	17.96	55.06	74.00	-18.94	peak

AV Result:

No.	Frequency (MHz)	Reading Level (dBuV/m)	Correct Factor (dB)	Result (dBuV/m)	Limit (dBuV/m)	Margin (dB)	Remark
1	4880.8601	42.48	5.33	47.81	54.00	-6.19	peak
2	16696.7121	26.69	18.00	44.69	54.00	-9.31	peak
3	17686.8359	27.75	17.96	45.71	54.00	-8.29	peak

- Note:
1. Measurement = Reading Level + Correct Factor.
 2. If Peak Result complies with AV limit, AV Result is deemed to comply with AV limit.
 3. Peak: Peak detector.
 4. For below 3GHz part, Filter losses were only considered in the spurious frequency bands and the authorized band was not corrected for Band Reject Filter losses.
 5. For above 3GHz part, Filter losses were only considered in the spurious frequency bands and the authorized band was not corrected for HPF losses.
 6. Proper operation of the transmitter prior to adding the filter to the measurement chain.
 7. Only the worst case emission was recorded, if it complies with the limit, the other emissions deemed to comply with the limit.



HARMONICS AND SPURIOUS EMISSIONS (CH39, HORIZONTAL)

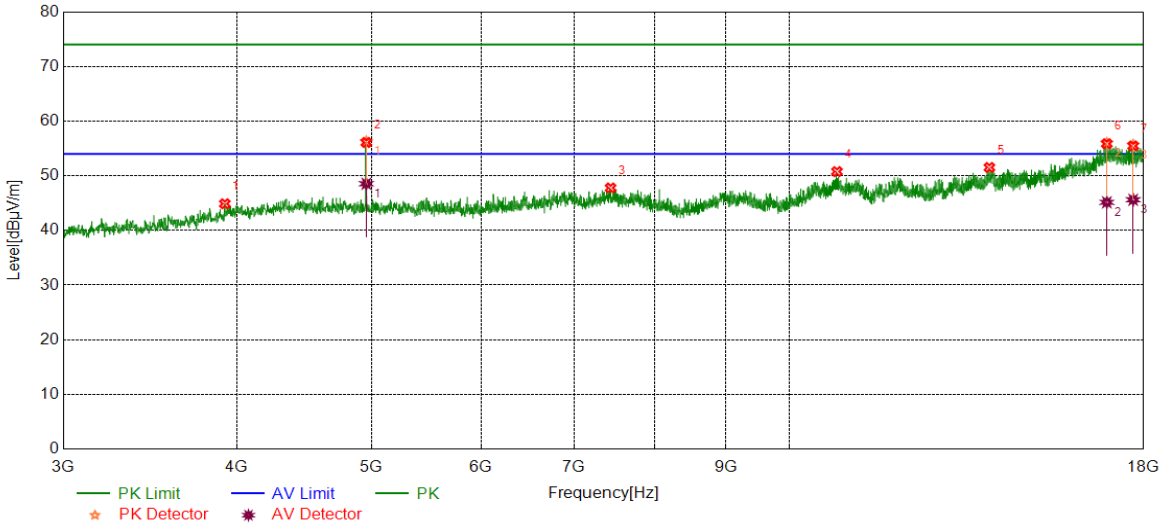

Peak Result:

No.	Frequency (MHz)	Reading Level (dBuV/m)	Correct Factor (dB)	Result (dBuV/m)	Limit (dBuV/m)	Margin (dB)	Remark
1	4959.6200	50.64	5.61	56.25	74.00	-17.75	peak
2	4959.6200	50.48	5.61	56.09	74.00	-17.91	peak
3	7436.8046	39.17	8.61	47.78	74.00	-26.22	peak
4	10823.4779	38.61	12.16	50.77	74.00	-23.23	peak
5	13936.3670	37.11	14.41	51.52	74.00	-22.48	peak
6	16932.9916	37.57	18.39	55.96	74.00	-18.04	peak
7	17688.7111	37.66	17.96	55.62	74.00	-18.38	peak

AV Result:

No.	Frequency (MHz)	Reading Level (dBuV/m)	Correct Factor (dB)	Result (dBuV/m)	Limit (dBuV/m)	Margin (dB)	Remark
1	4959.6200	42.93	5.61	48.54	54.00	-5.46	peak
2	16932.9916	26.75	18.39	45.14	54.00	-8.86	peak
3	17688.7111	27.65	17.96	45.61	54.00	-8.39	peak

- Note:
1. Measurement = Reading Level + Correct Factor.
 2. If Peak Result complies with AV limit, AV Result is deemed to comply with AV limit.
 3. Peak: Peak detector.
 4. For below 3GHz part, Filter losses were only considered in the spurious frequency bands and the authorized band was not corrected for Band Reject Filter losses.
 5. For above 3GHz part, Filter losses were only considered in the spurious frequency bands and the authorized band was not corrected for HPF losses.
 6. Proper operation of the transmitter prior to adding the filter to the measurement chain.
 7. Only the worst case emission was recorded, if it complies with the limit, the other emissions deemed to comply with the limit.

HARMONICS AND SPURIOUS EMISSIONS (CH39, VERTICAL)

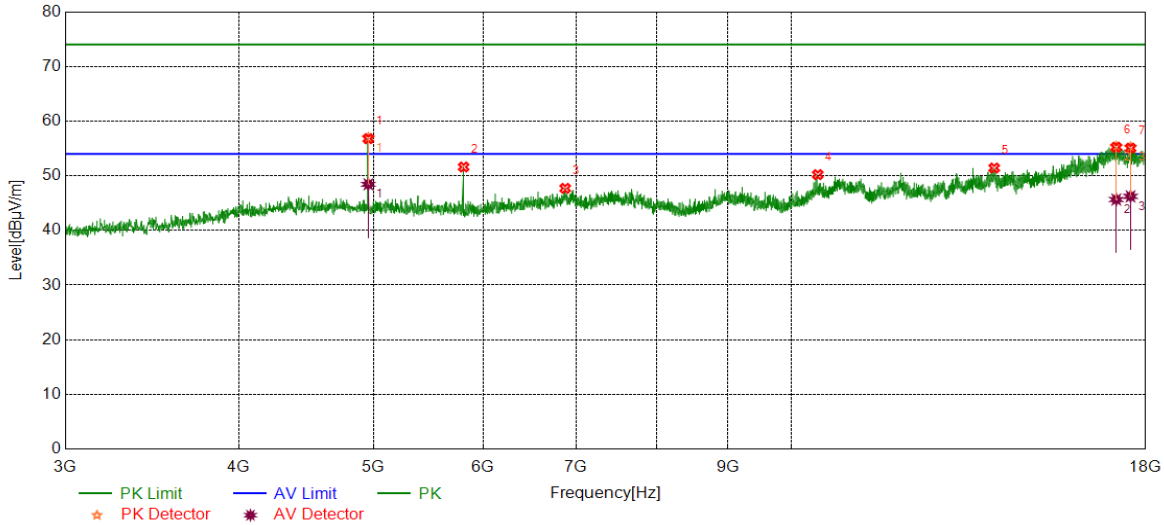

Peak Result:

No.	Frequency (MHz)	Reading Level (dBuV/m)	Correct Factor (dB)	Result (dBuV/m)	Limit (dBuV/m)	Margin (dB)	Remark
1	4959.6200	51.28	5.61	56.89	74.00	-17.11	peak
2	5809.1011	46.26	5.35	51.61	74.00	-22.39	peak
3	6874.2343	39.58	8.12	47.70	74.00	-26.30	peak
4	10450.3063	38.87	11.34	50.21	74.00	-23.79	peak
5	14002.0003	37.07	14.35	51.42	74.00	-22.58	peak
6	17143.0179	36.99	18.28	55.27	74.00	-18.73	peak
7	17553.6942	37.16	18.01	55.17	74.00	-18.83	peak

AV Result:

No.	Frequency (MHz)	Reading Level (dBuV/m)	Correct Factor (dB)	Result (dBuV/m)	Limit (dBuV/m)	Margin (dB)	Remark
1	4959.6200	42.83	5.61	48.44	54.00	-5.56	peak
2	17143.0179	27.37	18.28	45.65	54.00	-8.35	peak
3	17553.6942	28.22	18.01	46.23	54.00	-7.77	peak

- Note:
1. Measurement = Reading Level + Correct Factor.
 2. If Peak Result complies with AV limit, AV Result is deemed to comply with AV limit.
 3. Peak: Peak detector.
 4. For below 3GHz part, Filter losses were only considered in the spurious frequency bands and the authorized band was not corrected for Band Reject Filter losses.
 5. For above 3GHz part, Filter losses were only considered in the spurious frequency bands and the authorized band was not corrected for HPF losses.
 6. Proper operation of the transmitter prior to adding the filter to the measurement chain.
 7. Only the worst case emission was recorded, if it complies with the limit, the other emissions deemed to comply with the limit.



8.4. SPURIOUS EMISSIONS (18-26GHz)

SPURIOUS EMISSIONS (CH19, WORST-CASE CONFIGURATION, HORIZONTAL)

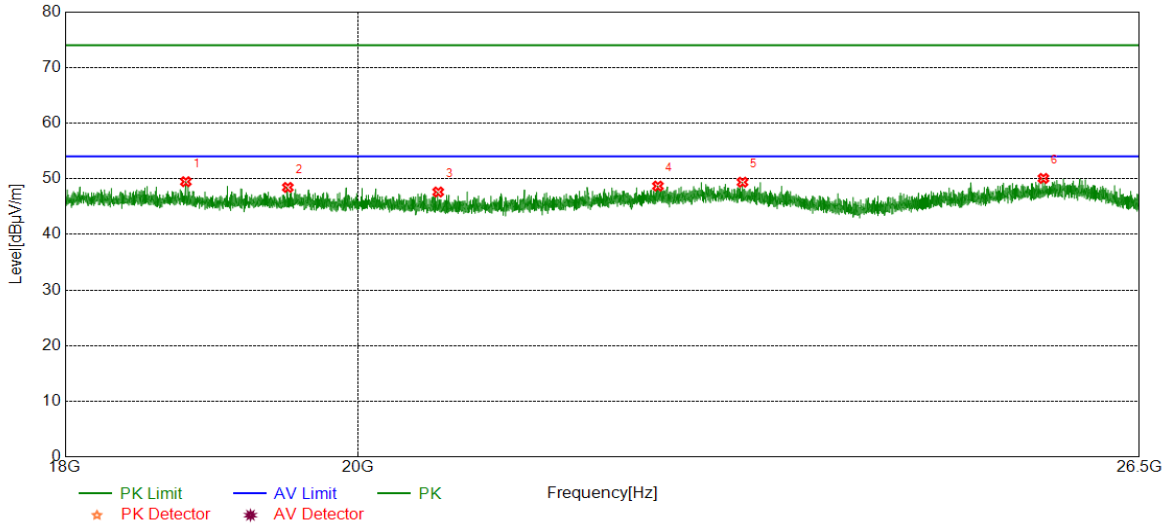

Peak Result:

No.	Frequency (MHz)	Reading Level (dBuV/m)	Correct Factor (dB)	Result (dBuV/m)	Limit (dBuV/m)	Margin (dB)	Remark
1	18799.9300	50.52	-1.05	49.47	74.00	-24.53	peak
2	19502.9503	49.16	-0.72	48.44	74.00	-25.56	peak
3	20588.5089	48.39	-0.77	47.62	74.00	-26.38	peak
4	22283.5784	48.16	0.52	48.68	74.00	-25.32	peak
5	22972.9973	48.17	1.21	49.38	74.00	-24.62	peak
6	25602.3102	49.04	1.02	50.06	74.00	-23.94	peak

- Note: 1. Measurement = Reading Level + Correct Factor.
 2. If Peak Result complies with AV limit, AV Result is deemed to comply with AV limit.
 3. Peak: Peak detector.
 4. Only the worst case emission was recorded, if it complies with the limit, the other emissions deemed to comply with the limit.



SPURIOUS EMISSIONS (CH19, WORST-CASE CONFIGURATION, VERTICAL)

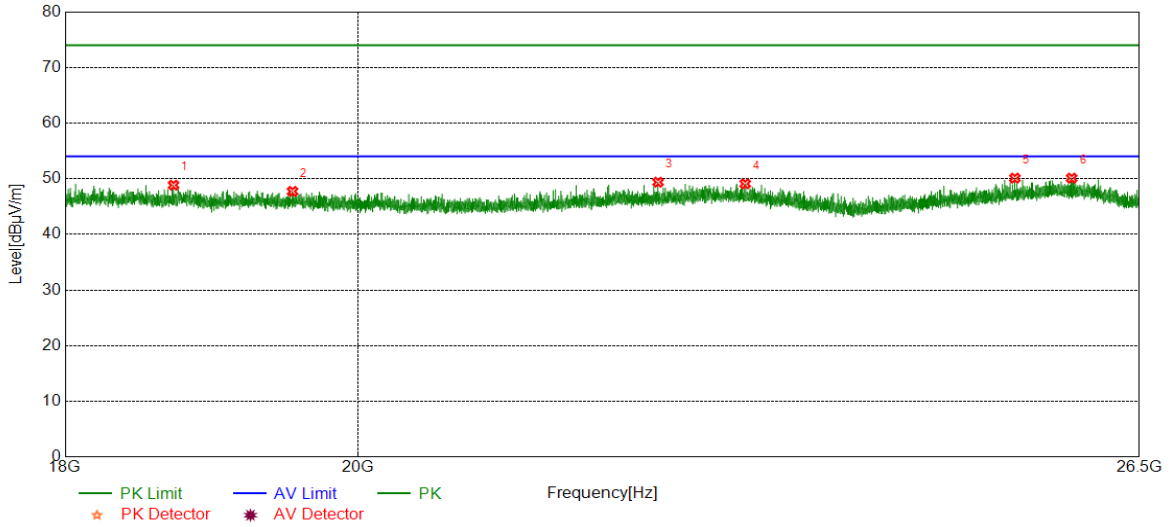

Peak Result:

No.	Frequency (MHz)	Reading Level (dBuV/m)	Correct Factor (dB)	Result (dBuV/m)	Limit (dBuV/m)	Margin (dB)	Remark
1	18716.6217	49.85	-1.00	48.85	74.00	-25.15	peak
2	19536.1036	48.44	-0.71	47.73	74.00	-26.27	peak
3	22285.2785	48.86	0.52	49.38	74.00	-24.62	peak
4	22995.0995	47.86	1.23	49.09	74.00	-24.91	peak
5	25340.4840	49.53	0.58	50.11	74.00	-23.89	peak
6	25864.1364	48.67	1.44	50.11	74.00	-23.89	peak

- Note: 1. Measurement = Reading Level + Correct Factor.
 2. If Peak Result complies with AV limit, AV Result is deemed to comply with AV limit.
 3. Peak: Peak detector.
 4. Only the worst case emission was recorded, if it complies with the limit, the other emissions deemed to comply with the limit.

Note: All constructions and test modes have been tested, only the worst data record in the report



8.5. SPURIOUS EMISSIONS (0.03-1 GHz)

SPURIOUS EMISSIONS (CH19, WORST-CASE CONFIGURATION, HORIZONTAL)

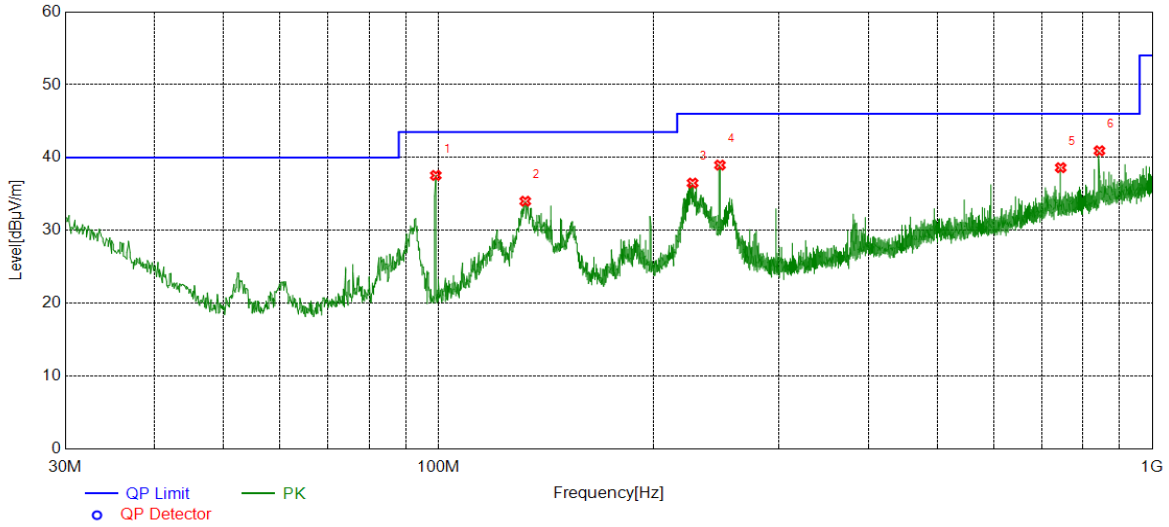

No.	Frequency (MHz)	Reading Level (dBuV/m)	Correct Factor (dB)	Result (dBuV/m)	Limit (dBuV/m)	Margin (dB)	Remark
1	99.1679	20.88	16.67	37.55	43.50	-5.95	peak
2	132.3452	13.86	20.15	34.01	43.50	-9.49	peak
3	227.0267	18.46	18.04	36.50	46.00	-9.50	peak
4	247.9808	20.00	18.96	38.96	46.00	-7.04	peak
5	744.2824	9.55	29.06	38.61	46.00	-7.39	peak
6	843.3293	10.57	30.36	40.93	46.00	-5.07	peak

- Note: 1. Result Level = Read Level + Correct Factor.
 2. If Peak Result complies with QP limit, QP Result is deemed to comply with QP limit.
 3. Test setup: RBW: 120 kHz, VBW: 300 kHz, Sweep time: auto.



SPURIOUS EMISSIONS (CH19, WORST-CASE CONFIGURATION, VERTICAL)

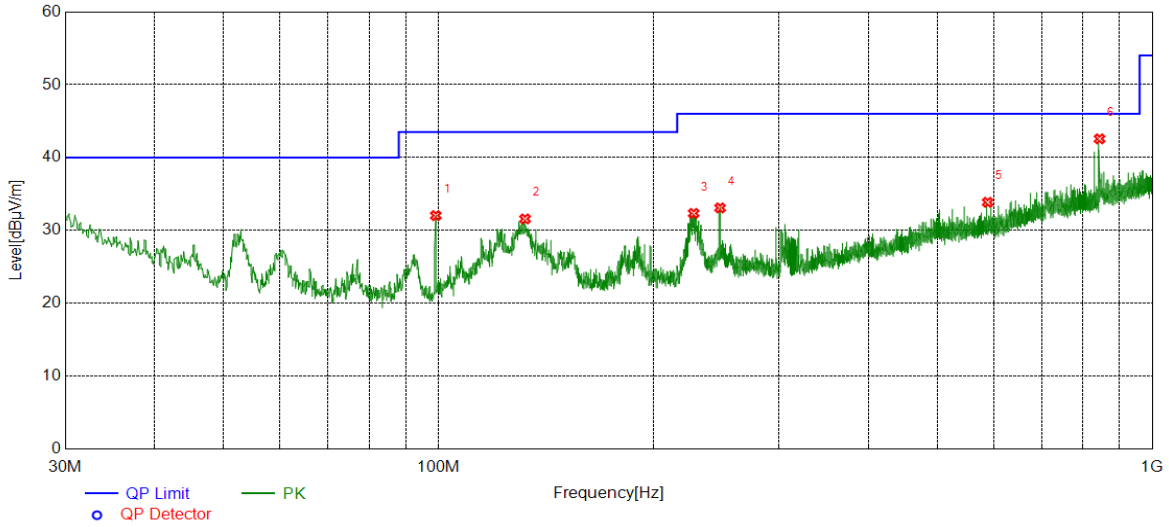

No.	Frequency (MHz)	Reading Level (dBuV/m)	Correct Factor (dB)	Result (dBuV/m)	Limit (dBuV/m)	Margin (dB)	Remark
1	99.1679	15.37	16.67	32.04	43.50	-11.46	peak
2	132.2482	11.43	20.15	31.58	43.50	-11.92	peak
3	227.8028	14.24	18.10	32.34	46.00	-13.66	peak
4	248.0778	14.13	18.96	33.09	46.00	-12.91	peak
5	587.9998	7.37	26.49	33.86	46.00	-12.14	peak
6	843.6204	12.21	30.36	42.57	46.00	-3.43	peak

Note: 1. Result Level = Read Level + Correct Factor.
 2. If Peak Result complies with QP limit, QP Result is deemed to comply with QP limit.
 3. Test setup: RBW: 120 kHz, VBW: 300 kHz, Sweep time: auto.

Note: All constructions and test modes have been tested, only the worst data record in the report.

8.6. SPURIOUS EMISSIONS BELOW 30M

SPURIOUS EMISSIONS (CH19, WORST-CASE CONFIGURATION, Face-on)

9kHz ~ 150kHz

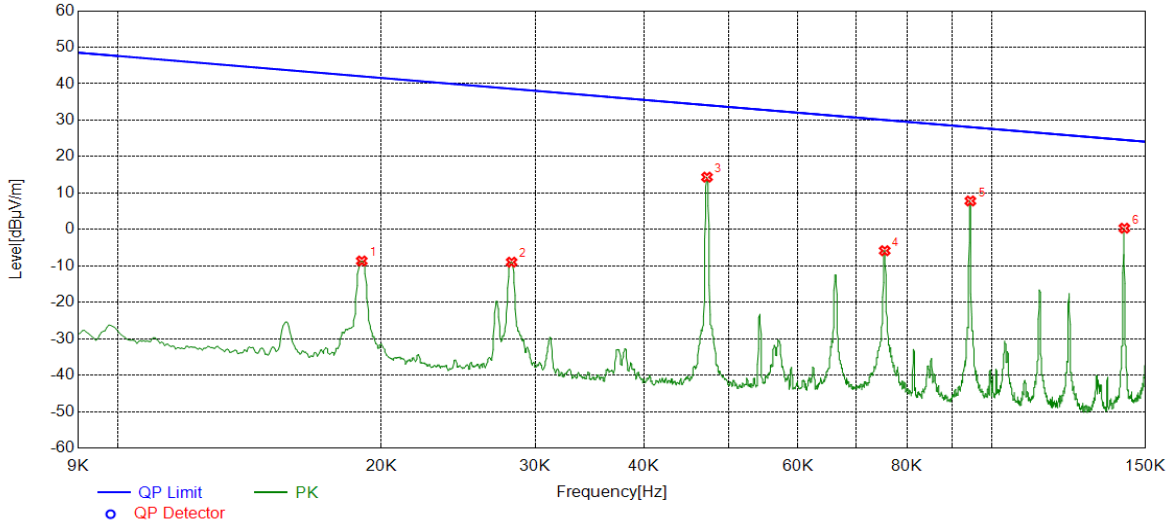

No.	Frequency (MHz)	Reading Level (dBuV/m)	Correct Factor (dB)	Result (dBuV/m)	Limit (dBuV/m)	Margin (dB)	Remark
1	0.0190	53.20	-61.86	-8.66	42.02	-50.68	peak
2	0.0282	52.78	-61.76	-8.98	38.59	-47.57	peak
3	0.0472	76.09	-61.74	14.35	34.12	-19.77	peak
4	0.0754	55.97	-61.81	-5.84	30.05	-35.89	peak
5	0.0945	69.63	-61.82	7.81	28.09	-20.28	peak
6	0.1418	62.18	-61.84	0.34	24.57	-24.23	peak

- Note: 1. Measurement = Reading Level + Correct Factor.
 2. If Peak Result complies with AV and QP limit, AV and QP Result are deemed to comply with AV limit.
 3. All 3 polarizations(Horizontal, Face-on and Face-off) of the loop antenna had been tested, but only the worst data recorded in the report



150kHz ~ 490kHz

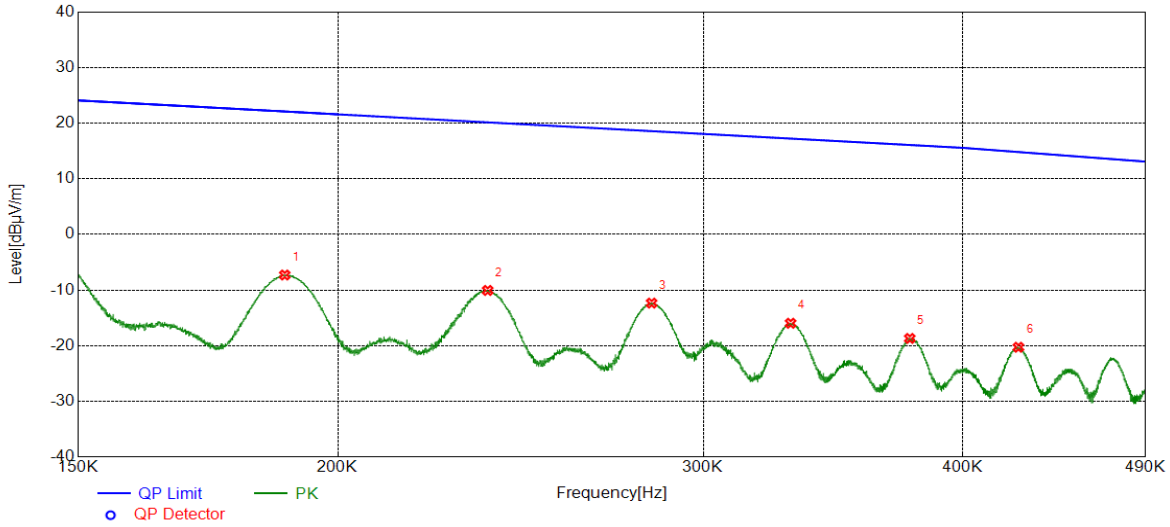

No.	Frequency (MHz)	Reading Level (dBuV/m)	Correct Factor (dB)	Result (dBuV/m)	Limit (dBuV/m)	Margin (dB)	Remark
1	0.1886	54.56	-61.86	-7.30	22.10	-29.40	peak
2	0.2362	51.81	-61.88	-10.07	20.14	-30.21	peak
3	0.2833	49.54	-61.89	-12.35	18.56	-30.91	peak
4	0.3305	45.93	-61.90	-15.97	17.22	-33.19	peak
5	0.3772	43.20	-61.90	-18.70	16.07	-34.77	peak
6	0.4255	41.62	-61.90	-20.28	14.80	-35.08	peak

- Note: 1. Measurement = Reading Level + Correct Factor.
 2. If Peak Result complies with AV and QP limit, AV and QP Result are deemed to comply with AV limit.
 3. All 3 polarizations(Horizontal, Face-on and Face-off) of the loop antenna had been tested, but only the worst data recorded in the report



490kHz ~ 30MHz

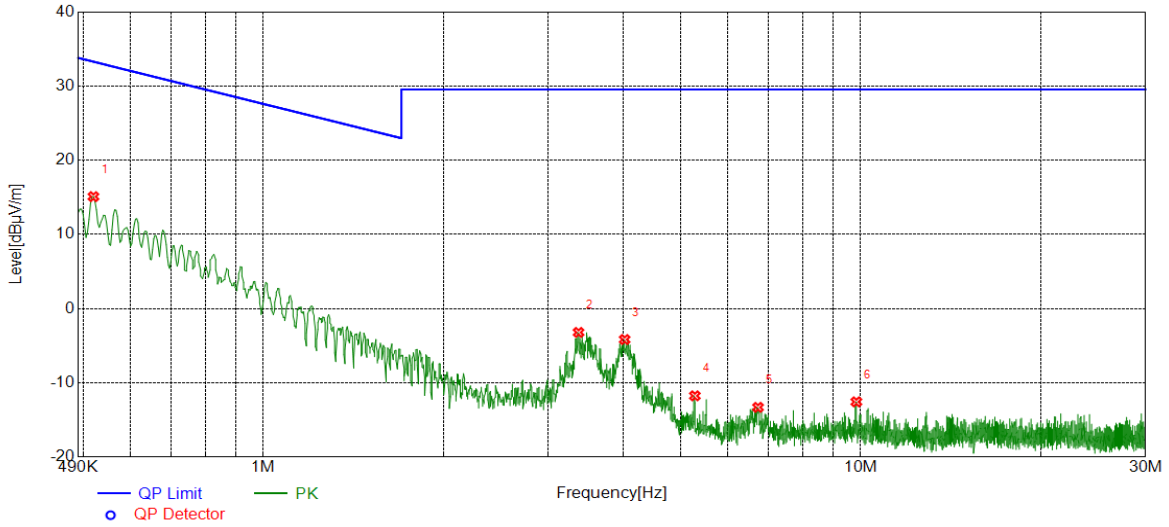

No.	Frequency (MHz)	Reading Level (dBuV/m)	Correct Factor (dB)	Result (dBuV/m)	Limit (dBuV/m)	Margin (dB)	Remark
1	0.5195	36.98	-21.89	15.09	33.29	-18.20	peak
2	3.3705	18.55	-21.76	-3.21	29.54	-32.75	peak
3	4.0257	17.57	-21.74	-4.17	29.54	-33.71	peak
4	5.2770	9.95	-21.71	-11.76	29.54	-41.30	peak
5	6.7320	8.39	-21.70	-13.31	29.54	-42.85	peak
6	9.8338	9.03	-21.60	-12.57	29.54	-42.11	peak

- Note: 1. Measurement = Reading Level + Correct Factor.
 2. If Peak Result complies with AV and QP limit, AV and QP Result are deemed to comply with AV limit.
 3. All 3 polarizations(Horizontal, Face-on and Face-off) of the loop antenna had been tested, but only the worst data recorded in the report

Note: All constructions and test modes and channels have been tested, only the worst data record in the report.



9. ANTENNA REQUIREMENTS

APPLICABLE REQUIREMENTS

Please refer to FCC §15.203

An intentional radiator shall be designed to ensure that no antenna other than that furnished by the responsible party shall be used with the device. The use of a permanently attached antenna or of an antenna that uses a unique coupling to the intentional radiator shall be considered sufficient to comply with the provisions of this section. The manufacturer may design the unit so that a broken antenna can be replaced by the user, but the use of a standard antenna jack or electrical connector is prohibited.

Please refer to FCC §15.247(b)(4)

The conducted output power limit specified in paragraph (b) of this section is based on the use of antennas with directional gains that do not exceed 6 dBi. Except as shown in paragraph (c) of this section, if transmitting antennas of directional gain greater than 6 dBi are used, the conducted output power from the intentional radiator shall be reduced below the stated values in paragraphs (b)(1), (b)(2), and (b)(3) of this section, as appropriate, by the amount in dB that the directional gain of the antenna exceeds 6 dBi.

RESULTS

Complies

END OF REPORT