

TEST REPORT

Report No.: SHATBL2408001W01

Applicant : SHENZHEN AIERJI TONGXIN YOUXIAN GONGSI
Product Name : Wireless game headphones
Brand Name : N/A
Model Name : G724X
FCC ID : 2AYO2-G724X
Test Standard : 47 CFR 15.247
Date of Test : 2024.07.30-2024.08.21

Report Prepared by : Chris Xu
(Chris Xu)

Report Approved by : Ghost Li.
(Ghost Li)

Authorized Signatory : Terry Yang
(Terry Yang)



TABLE OF CONTENTS

REVISION HISTORY	3
DECLARATION OF REPORT	4
SUMMARY OF TEST RESULT	5
1. GENERAL DESCRIPTION	6
1.1. Applicant	6
1.2. Manufacturer	6
1.3. Factory	6
1.4. General Information of EUT	7
1.5. Equipment Specification	8
1.6. Modification of EUT	8
1.7. Laboratory Information	8
1.8. Applicable Standards	8
2. TEST CONFIGURATION OF EUT	9
2.1. Carrier Frequency Channel	9
2.2. Test Modes	10
2.3. Block Diagram of Test System	11
2.4. Description of Support Units	11
2.5. Test Software and Power Level	11
2.6. EUT Operating Conditions	11
2.7. Equipment List	12
2.8. Measurement Uncertainty	14
3. TEST RESULT	15
3.1. Maximum Peak Conducted Output Power	15
3.2. Number of Hopping Frequencies	17
3.3. Duty Cycle and Dwell Time	18
3.4. 20dB Bandwidth	19
3.5. Carrier Frequency Separation	20
3.6. Conducted Band Edge	21
3.7. Conducted Spurious Emission	22
3.8. Radiated Spurious Emission and Restricted Band	23
3.9. AC Power-Line Conducted Emission	64
3.10. Antenna Requirement	66
4. TEST SETUP PHOTOGRAPHS	67
5. EXTERNAL AND INTERNAL PHOTOS OF THE EUT	67

REVISION HISTORY

Rev.	Issue Date	Revisions	Revised by
00	2024.8.21	Initial Release	Ghost Li

DECLARATION OF REPORT

1. The device has been tested by ATBL, and the test results show that the equipment under test (EUT) is in compliance with the requirements of 47 CFR 15.247. And it is applicable only to the tested sample identified in the report.
2. This report shall not be reproduced except in full, without the written approval of ATBL, this document only be altered or revised by ATBL, personal only, and shall be noted in the revision of the document.
3. The general information of EUT in this report is provided by the customer or manufacture, ATBL is only responsible for the test data but not for the information provided by the customer or manufacture.
4. The results in this report is only apply to the sample as tested under conditions. The customer or manufacturer is responsible for ensuring that the additional production units of this model have the same electrical and mechanical components.
5. In this report, '' indicates that EUT does not support content after '' , and '' indicates that it supports content after ''

SUMMARY OF TEST RESULT

Report Section	Standard Section	Test Item	Judgment	Remark
3.1	47 CFR 15.247(b)(1)	Maximum Peak Conducted Output Power	PASS	--
3.2	47 CFR 15.247(a)(1)(iii)	Number of Hopping Frequencies	PASS	--
3.3	47 CFR 15.247(a)(1)(iii)	Duty Cycle and Dwell Time	PASS	--
3.4	47 CFR 15.247(a)(1)	20dB Bandwidth	Report only	--
3.5	47 CFR 15.247(a)(1)	Carrier Frequency Separation	PASS	--
3.6	47 CFR 15.247(d)	Conducted Band Edge	PASS	--
3.7	47 CFR 15.247(d)	Conducted Spurious Emission	PASS	--
3.8	47 CFR 15.247(d)/15.209(a)/15.205(a)	Radiated Spurious Emission and Restricted Band	PASS	--
3.9	47 CFR 15.207(a)	AC Power-Line Conducted Emission	N/A	--
3.10	47 CFR 15.203	Antenna Requirements	PASS	--

1. GENERAL DESCRIPTION

1.1. Applicant

Name : SHENZHEN AIERJI TONGXIN YOUXIAN GONGSI
Address : 404, Building 47, Dayun Software Town, 8288 Longgang Avenue, He'ao Community, Yuanshan Street,Longgang District, Shenzhen, Guangdong,China

1.2. Manufacturer

Name : SHENZHEN AIERJI TONGXIN YOUXIAN GONGSI
Address : 404, Building 47, Dayun Software Town, 8288 Longgang Avenue, He'ao Community, Yuanshan Street,Longgang District, Shenzhen, Guangdong,China

1.3. Factory

Name : SHENZHEN AIERJI TONGXIN YOUXIAN GONGSI
Address : 404, Building 47, Dayun Software Town, 8288 Longgang Avenue, He'ao Community, Yuanshan Street,Longgang District, Shenzhen, Guangdong,China

1.4. General Information of EUT

General Information	
Equipment Name	Wireless game headphones
Brand Name	N/A
Model Name	G724X
Series Model	G721, G722, G723, G725, G726, G727, G728, G729, G730
Model Difference	The model names are different, but the rest are exactly the same
Antenna Type	ceramic antenna
Antenna Gain	1.15dBi
Sample No:	202407240006002
Battery	Rated Voltage: DC3.7V Charge Limit Voltage: DC5V Capacity: 1200mAh
Hardware version	5.3
Software version	1.2
Connecting I/O Port(s)	Refer to the remark below.

Remark:

The above information of EUT was declared by manufacturer. Please refer to the specifications or user's manual for more detailed description.

1.5. Equipment Specification

Equipment Specification		
Frequency Range	2400MHz - 2483.5MHz	
Number of Channels	79	
Carrier Frequency of Each Channel	2402 + n*1 MHz; n = 0 ~ 78	
Maximum Output Power To Antenna	<input checked="" type="checkbox"/> Bluetooth BR(1Mbps):	-4.214dBm (0.000379W)
	<input checked="" type="checkbox"/> Bluetooth EDR(2Mbps):	-3.252dBm (0.000473W)
	<input checked="" type="checkbox"/> Bluetooth EDR(3Mbps):	-2.865dBm (0.000517W)
Type of Modulation	<input checked="" type="checkbox"/> Bluetooth BR(1Mbps):	GFSK
	<input checked="" type="checkbox"/> Bluetooth EDR(2Mbps):	$\pi/4$ -DQPSK
	<input checked="" type="checkbox"/> Bluetooth EDR(3Mbps):	8-DPSK

1.6. Modification of EUT

No modifications are made to the EUT during all test items.

1.7. Laboratory Information

Company Name	: Shanghai ATBL Technology Co., Ltd.
Address	: Building 8, No.160 Basheng Road, Waigaoqiao Free Trade Zone, Pudong New Area, Shanghai
Telephone	: +86(0)21-51298625

1.8. Applicable Standards

According to the specifications of the manufacturer, the EUT must comply with the requirements of the following standards:

47 CFR Part 15 Subpart C §15.247

FCC KDB 558074 D01 15.247 Meas Guidance v05r02

ANSI C63.10-2013

Remark:

All test items were verified and recorded according to the standards and without any deviation during the test.

2. TEST CONFIGURATION OF EUT

2.1. Carrier Frequency Channel

Frequency Band	Channel	Frequency MHz	Channel	Frequency MHz	Channel	Frequency MHz
2400 - 2483.5 MHz	00	2402	27	2429	54	2456
	01	2403	28	2430	55	2457
	02	2404	29	2431	56	2458
	03	2405	30	2432	57	2459
	04	2406	31	2433	58	2460
	05	2407	32	2434	59	2461
	06	2408	33	2435	60	2462
	07	2409	34	2436	61	2463
	08	2410	35	2437	62	2464
	09	2411	36	2438	63	2465
	10	2412	37	2439	64	2466
	11	2413	38	2440	65	2467
	12	2414	39	2441	66	2468
	13	2415	40	2442	67	2469
	14	2416	41	2443	68	2470
	15	2417	42	2444	69	2471
	16	2418	43	2445	70	2472
	17	2419	44	2446	71	2473
	18	2420	45	2447	72	2474
	19	2421	46	2448	73	2475
	20	2422	47	2449	74	2476
	21	2423	48	2450	75	2477
	22	2424	49	2451	76	2478
	23	2425	50	2452	77	2479
	24	2426	51	2453	78	2480
	25	2427	52	2454	--	--
	26	2428	53	2455	--	--

Remark:

Low Channel: **CH00_2402 MHz**; Middle Channel: **CH39_2441 MHz**; High Channel: **CH78_2480 MHz**.

2.2. Test Modes

The table below is showing all test modes to demonstrate in compliance with the standard.

Summary Table of Test Modes			
Test Item	Data Rate / Modulation		
	Bluetooth BR(1Mbps) GFSK	Bluetooth EDR(2Mbps) $\pi/4$ -DQPSK	Bluetooth EDR(3Mbps) 8-DPSK
For Conducted and Radiated Test	Mode 1: CH00_2402 MHz	Mode 2: CH00_2402 MHz	Mode 3: CH00_2402 MHz
	Mode 4: CH39_2441 MHz	Mode 5: CH39_2441 MHz	Mode 6: CH39_2441 MHz
	Mode 7: CH78_2480 MHz	Mode 8: CH78_2480 MHz	Mode 9: CH78_2480 MHz
	Mode 10: Hopping	Mode 11: Hopping	Mode 12: Hopping
For AC Power-line Conducted Emission	Mode 13: Keep Bluetooth link under the maximum output power		

2.3. Block Diagram of Test System

2.3.1. For AC Power-Line Conducted Emission

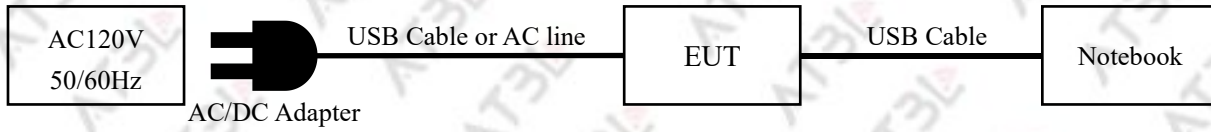

2.3.2. For Radiated Spurious Emission



2.3.3. For Conducted Test



2.4. Description of Support Units

NO.	Unit	Brand	Model	Description
1	Notebook	Lenovo	Air 14	/
2	USB Line	ZL	24AWG	/

2.5. Test Software and Power Level

During the test, the channel and power control software provided by the customer is used to control the operation channel and output power level.

2.6. EUT Operating Conditions

For AC power-line conducted emission, the EUT was connected under the large package sizes transmission.

For radiated spurious emission and conducted test, the engineering test program was provided and make the EUT to continuous transmit/receive.

2.7. Equipment List

2.7.1. For AC Power-Line Conducted Emission

Equipment Name	Manufacturer	Model	Serial No.	Equipment No.	Calibration Until	Classification
Test Receiver	R&S	ESPI	101679	SHATBL-E012	2025.05.21	(c)
LISN	R&S	ENV216	100300	SHATBL-E013	2025.05.21	(c)
LISN	R&S	ENV216	100333	SHATBL-E041	2025.05.21	(c)
Thermometer	DeLi	N/A	N/A	SHATBL-E016	2024.09.20	(c)
Test Software	FALA	EZ-EMC	N/A	SHATBL-E046	N/A	(c)

2.7.2. For Radiated Spurious Emission

Equipment Name	Manufacturer	Model	Serial No.	Equipment No.	Calibration Until	Classification
Signal analyzer	Agilent	N9020A	MY50200811	SHATBL-E017	2025.05.21	(c)
Amplifier	JPT	JPA0118-55-303A	191000180005500	SHATBL-E006	2025.05.21	(c)
Amplifier	JPT	JPA-10M1G32	21010100035001	SHATBL-E005	2025.05.21	(c)
Antenna/Turntable Controller	Brilliant	N/A	N/A	SHATBL-E007	N/A	(c)
Loop Antenna	Daze	ZN30900C	20077	SHATBL-E042	2025.05.21	(c)
Bilog Antenna	SCHWARZBECK	VULB 9168	01174	SHATBL-E008	2025.05.21	(c)
Broad-band Horn Antenna	SCHWARZBECK	BBHA 9120D	02334	SHATBL-E009	2025.05.21	(c)
Horn Antenna	COM-POWER	AH-1840	10100008	SHATBL-E043	2025.05.21	(c)
Thermometer	DeLi	N/A	N/A	SHATBL-E015	2024.09.20	(c)
Test Software	FALA	EMC-RI	N/A	SHATBL-E046	N/A	(c)

2.7.3. For Conducted Test

Equipment Name	Manufacturer	Model	Serial No.	Equipment No.	Calibration Until	Classification
Power meter	Anritsu	ML2496A	1935001	SHATBL-W030	2024.09.27	(c)
Power sensor	Anritsu	MA2411B	1911006	SHATBL-W031	2024.09.27	(c)
Power sensor	DARE	RPR3006W	16I00054SN016	SHATBL-W008	2024.09.27	(c)
Power sensor	DARE	RPR3006W	RPR6W-2001005	SHATBL-W032	2024.09.27	(c)
Power sensor	Rediteq	RPR3006W	RPR6W-2201002	SHATBL-W033	2024.11.15	(c)
Power sensor	Rediteq	RPR3006W	RPR6W-2201003	SHATBL-W034	2024.11.15	(c)
Power sensor	Keysight	U2021XA	MY59120004	SHATBL-W035	2025.08.13	(c)
Adjustable Attenuator	Agilent	8494B	MY42144015	SHATBL-W009	2024.09.27	(c)
Adjustable Attenuator	Agilent	8496B	MY42143776	SHATBL-W010	2024.09.27	(c)
Environmental Test Chamber	KSON	THS-B6C-150	9159K	SHATBL-W019	2025.01.17	(c)
Signal analyzer	Keysight	N9020A	MY50510136	SHATBL-W003	2024.09.27	(c)
Vector signal generator	Keysight	N5182B	MY57300196	SHATBL-W005	2024.09.27	(c)
Vector signal generator	Agilent	N5182A	MY50143555	SHATBL-W037	2025.07.17	(c)
Analog signal generator	Keysight	N5173B	MY60403026	SHATBL-W038	2025.07.17	(c)
Wideband radio communication tester	R&S	CMW500	101331	SHATBL-W007	2024.09.27	(c)
Spectrum analyzer	R&S	FSV40-N	101761	SHATBL-W036	2024.08.23	(c)
Switch Box	N/A	RFSW3003328	RFSW201019	SHATBL-W029	N/A	(c)
Thermometer	DeLi	N/A	N/A	SHATBL-W012	2024.09.20	(c)
Test Software	FALA	LZ-RF	N/A	SHATBL-W020	N/A	(c)

Remark:

(a) Calibration conducted by the National institute of Information and Communications Technology (NICT) in Japan (hereinafter referred to as "NICT") or a designated calibration agency under Article 102-18 paragraph(1) in JRL.

(b) Correction conducted pursuant to the provisions of Article 135 or Article 144 of the Measurement Act (ActNo. 51 of 1992).

(c) Calibration conducted in countries except Japan, which shall be equivalent to the calibration conducted by the NICT or a designated calibration agency under Article 102-18 paragraph (1). (d) Calibration, etc. conducted by using measuring instruments and other equipment listed in the right column of appended table No. 3, which shall have been given any type of calibration, etc. listed above from (a) to (c)

From JRL Article 24-2, paragraph 4, Item 2

Notice: Calibration duration for above equipments is 1 year.

2.8. Measurement Uncertainty

The reported uncertainty of measurement $y \pm U$, where expanded uncertainty U is based on a standard uncertainty multiplied by a coverage factor of $k=2$, providing a level of confidence of approximately 95 %.

No.	Item	Uncertainty
1	RF output power, conducted	$\pm 0.958\text{dB}$
2	Conducted spurious emissions(9KHz~30MHz)	$\pm 2.988\text{dB}$
	All emissions, radiated 9KHz~30MHz	$\pm 0.89\text{dB}$
3	All emissions, radiated 30MHz-1GHz	$\pm 2.50\text{dB}$
4	All emissions, radiated 1GHz-18GHz	$\pm 3.51\text{dB}$
5	Occupied bandwidth	$\pm 23.20\text{Hz}$
6	Power spectral density	$\pm 0.886\text{dB}$

3. TEST RESULT

3.1. Maximum Peak Conducted Output Power

3.1.1. Limit

47 CFR 15.247(b)(1): For frequency hopping systems operating in the 2400-2483.5 MHz band employing at least 75 non-overlapping hopping channels, and all frequency hopping systems in the 5725-5850 MHz band: 1 watt. For all other frequency hopping systems in the 2400-2483.5 MHz band: 0.125 watts.

3.1.2. Test Procedure

ANSI C63.10-2013 clause 7.8.5: This is an RF-conducted test to evaluate maximum peak output power. Use a direct connection between the antenna port of the unlicensed wireless device and the spectrum analyzer, through suitable attenuation. The hopping shall be disabled for this test:

1. Use the following spectrum analyzer settings:
 - ① Span: Approximately five times the 20 dB bandwidth, centered on a hopping channel.
 - ② RBW > 20 dB bandwidth of the emission being measured.
 - ③ VBW \geq RBW.
 - ④ Sweep: Auto.
 - ⑤ Detector function: Peak.
 - ⑥ Trace: Max hold.
2. Allow trace to stabilize.
3. Use the marker-to-peak function to set the marker to the peak of the emission.
4. The indicated level is the peak output power, after any corrections for external attenuators and cables.
5. A plot of the test results and setup description shall be included in the test report.

Remark:

A peak responding power meter may be used, where the power meter and sensor system video bandwidth is greater than the occupied bandwidth of the unlicensed wireless device, rather than a spectrum analyzer.

3.1.3. Test Setup

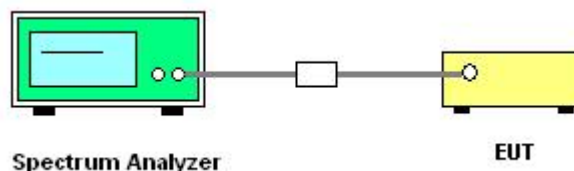

3.1.4. Test Result of Maximum Peak Conducted Output Power

Please refer to the Appendix A1.

3.2. Number of Hopping Frequencies

3.2.1. Limit

47 CFR 15.247(a)(1)(iii): Frequency hopping systems in the 2400-2483.5 MHz band shall use at least 15 channels.

3.2.2. Test Procedure

ANSI C63.10-2013 clause 7.8.3: The EUT shall have its hopping function enabled. Use the following spectrum analyzer settings:

1. Span: The frequency band of operation. Depending on the number of channels the device supports, it may be necessary to divide the frequency range of operation across multiple spans, to allow the individual channels to be clearly seen.

2. RBW: To identify clearly the individual channels, set the RBW to less than 30% of the channel spacing or the 20 dB bandwidth, whichever is smaller.

3. VBW \geq RBW.

4. Sweep: Auto.

5. Detector function: Peak.

6. Trace: Max hold.

7. Allow the trace to stabilize.

It might prove necessary to break the span up into sub ranges to show clearly all of the hopping frequencies. Compliance of an EUT with the appropriate regulatory limit shall be determined for the number of hopping channels. A plot of the data shall be included in the test report.

3.2.3. Test Setup

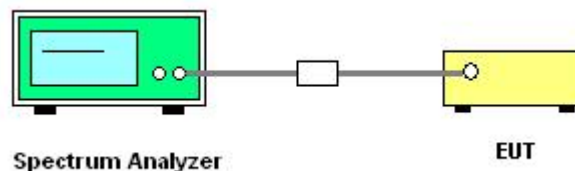

3.2.4. Test Result of Number of Hopping Frequencies

Please refer to the Appendix A6.

3.3. Duty Cycle and Dwell Time

3.3.1. Limit

47 CFR 15.247(a)(1)(iii): The average time of occupancy on any channel shall not be greater than 0.4 seconds within a period of 0.4 seconds multiplied by the number of hopping channels employed.

3.3.2. Test Procedure

ANSI C63.10-2013 clause 7.8.4: The EUT shall have its hopping function enabled. Use the following spectrum analyzer settings:

1. Span: Zero span, centered on a hopping channel.
2. RBW shall be \leq channel spacing and where possible RBW should be set $\gg 1 / T$, where T is the expected dwell time per channel.
3. Sweep: As necessary to capture the entire dwell time per hopping channel; where possible use a video trigger and trigger delay so that the transmitted signal starts a little to the right of the start of the plot. The trigger level might need slight adjustment to prevent triggering when the system hops on an adjacent channel; a second plot might be needed with a longer sweep time to show two successive hops on a channel.
4. Detector function: Peak.
5. Trace: Max hold.
6. Use the marker-delta function to determine the transmit time per hop.
7. The average time of occupancy is calculated from the transmit time per hop multiplied by the number of hops in the period specified in the requirements.

3.3.3. Test Setup

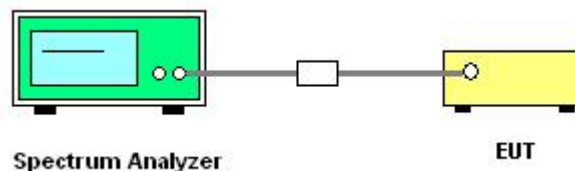

3.3.4. Test Result of Duty Cycle and Dwell Time

Please refer to the Appendix A5.

3.4. 20dB Bandwidth

3.4.1. Limit

There is no limit requirement for 20dB Bandwidth.

3.4.2. Test Procedure

1. The testing follows *ANSI C63.10-2013 clause 6.9.2 and 6.9.3*.
2. The RF output of EUT was connected to the spectrum analyzer by RF cable and attenuator. The path loss was compensated to the results for each measurement.
3. Set to the maximum power setting and enable the EUT transmit continuously.
4. Use the following spectrum analyzer settings for 20dB Bandwidth measurement. Span = approximately 2 to 3 times the 20 dB bandwidth, centered on a hopping channel; RBW \geq 1% of the 20 dB bandwidth; VBW \geq RBW; Sweep = auto; Detector function = peak; Trace = max hold.
5. Measure and record the results in the test report.

3.4.3. Test Setup

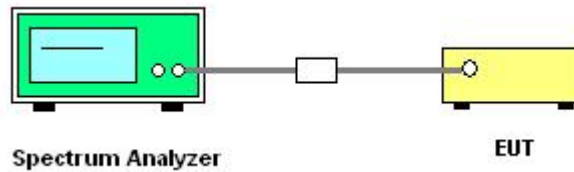

3.4.4. Test Result of 20dB Bandwidth

Please refer to the Appendix A2.

3.5. Carrier Frequency Separation

3.5.1. Limit

47 CFR 15.247(a)(1): Frequency hopping systems operating in the 2400-2483.5 MHz band may have hopping channel carrier frequencies that are separated by 25 kHz or two-thirds of the 20 dB bandwidth of the hopping channel, whichever is greater.

3.5.2. Test Procedure

ANSI C63.10-2013 clause 7.8.2: The EUT shall have its hopping function enabled. Use the following spectrum analyzer settings:

1. Span: Wide enough to capture the peaks of two adjacent channels.
2. RBW: Start with the RBW set to approximately 30% of the channel spacing; adjust as necessary to best identify the center of each individual channel.
3. VBW \geq RBW.
4. Sweep: Auto.
5. Detector function: Peak.
6. Trace: Max hold.
7. Allow the trace to stabilize.
8. Use the marker-delta function to determine the separation between the peaks of the adjacent channels. A plot of the data shall be included in the test report.

3.5.3. Test Setup

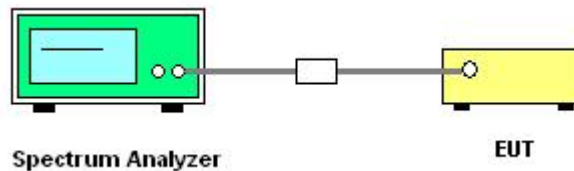

3.5.4. Test Result of Carrier Frequency Separation

Please refer to the Appendix A3.

3.6. Conducted Band Edge

3.6.1. Limit

47 CFR 15.247(d): In any 100 kHz bandwidth outside the frequency band in which the spread spectrum or digitally modulated intentional radiator is operating, the radio frequency power that is produced by the intentional radiator shall be at least 20 dB below that in the 100 kHz bandwidth within the band that contains the highest level of the desired power, based on either an RF conducted or a radiated measurement, provided the transmitter demonstrates compliance with the peak conducted power limits.

3.6.2. Test Procedure

1. The testing follows ANSI C63.10-2013 clause 11.13.
2. Set to the maximum power setting and enable the EUT transmit continuously.
3. Set RBW = 100 kHz, VBW=300 kHz, Peak Detector. Conducted Band Edge measured in any 100 kHz bandwidth outside of the authorized frequency band shall be attenuated by at least 20 dB relative to the 100 kHz bandwidth within the band that contains the highest level of the desired power when maximum peak conducted output power procedure is used. If the transmitter complies with the conducted power limits based on the use of RMS averaging over a time interval, the attenuation required under this paragraph shall be 30 dB instead of 20 dB.
4. Measure and record the results in the test report.
5. The RF fundamental frequency should be excluded against the limit line in the operating frequency band.

3.6.3. Test Setup

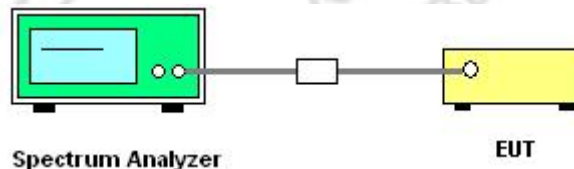

3.6.4. Test Result of Conducted Band Edge

Please refer to the Appendix A7.

3.7. Conducted Spurious Emission

3.7.1. Limit

47 CFR 15.247(d): In any 100 kHz bandwidth outside the frequency band in which the spread spectrum or digitally modulated intentional radiator is operating, the radio frequency power that is produced by the intentional radiator shall be at least 20 dB below that in the 100 kHz bandwidth within the band that contains the highest level of the desired power, based on either an RF conducted or a radiated measurement, provided the transmitter demonstrates compliance with the peak conducted power limits.

3.7.2. Test Procedure

1. The testing follows ANSI C63.10-2013 clause 7.8.8.
2. The RF output of EUT was connected to the spectrum analyzer by RF cable and attenuator. The path loss was compensated to the results for each measurement.
3. Set to the maximum power setting and enable the EUT transmit continuously.
4. Set RBW = 100 kHz, VBW = 300kHz, scan up through 10th harmonic. All harmonics / spurs must be at least 20 dB down from the highest emission level within the authorized band as measured with a 100 kHz RBW.
5. Measure and record the results in the test report.
6. The RF fundamental frequency should be excluded against the limit line in the operating frequency band.

3.7.3. Test Setup

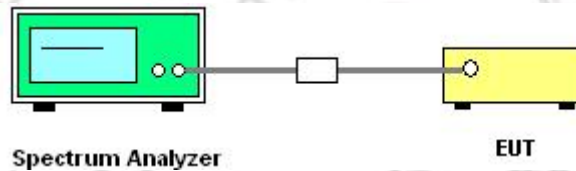

3.7.4. Test Result of Conducted Spurious Emission

Please refer to the Appendix A7.

3.8. Radiated Spurious Emission and Restricted Band

3.8.1. Limit

47 CFR 15.247(d): In any 100 kHz bandwidth outside the frequency band in which the spread spectrum or digitally modulated intentional radiator is operating, the radio frequency power that is produced by the intentional radiator shall be at least 20 dB below that in the 100 kHz bandwidth within the band that contains the highest level of the desired power, based on either an RF conducted or a radiated measurement, provided the transmitter demonstrates compliance with the peak conducted power limits.

47 CFR 15.205(a): Only spurious emissions are permitted in any of the frequency bands listed below:

Frequency (MHz)	Frequency (MHz)	Frequency (MHz)	Frequency (MHz)	Frequency (MHz)
0.090-0.110	12.29-12.293	149.9-150.05	1660-1710	8.025-8.5
0.495-0.505	12.51975-12.52025	156.52475-156.52525	1718.8-1722.2	9.0-9.2
2.1735-2.1905	12.57675-12.57725	156.7-156.9	2200-2300	9.3-9.5
4.125-4.128	13.36-13.41	162.0125-167.17	2310-2390	10.6-12.7
4.17725-4.17775	16.42-16.423	167.72-173.2	2483.5-2500	13.25-13.4
4.20725-4.20775	16.69475-16.69525	240-285	2690-2900	14.47-14.5
6.215-6.218	16.80425-16.80475	322-335.4	3260-3267	15.35-16.2
6.26775-6.26825	25.5-25.67	399.9-410	3332-3339	17.7-21.4
6.31175-6.31225	37.5-38.25	608-614	3345.8-3358	22.01-23.12
8.291-8.294	73-74.6	960-1240	3600-4400	23.6-24.0
8.362-8.366	74.8-75.2	1300-1427	4500-5150	31.2-31.8
8.37625-8.38675	108-121.94	1435-1626.5	5350-5460	36.43-36.5
8.41425-8.41475	123-138	1645.5-1646.5	7250-7750	Above 38.6

47 CFR 15.209(a): The emissions from an intentional radiator shall not exceed the field strength levels specified in the following table:

Frequency (MHz)	Field strength (microvolts/meter)	Measurement distance (meters)
0.009-0.490	2400/F(kHz)	300
0.490-1.705	24000/F(kHz)	30
1.705-30.0	30	30
30-88	100	3
88-216	150	3
216-960	200	3
Above 960	500	3

3.8.2. Test Procedure

1. The EUT was placed on a turntable with 0.8 meter for frequency below 1GHz and 1.5 meter for frequency above 1GHz respectively above ground.

2. The EUT was set 3 meters from the interference receiving antenna, which was mounted on the top of a variable height antenna tower.

3. For each suspected emission, the EUT was arranged to its worst case and then tune the Antenna tower (from 1 m to 4 m) and turntable (from 0 degree to 360 degrees) to find the maximum reading. A pre-amp and a high pass filter are used for the test in order to get better signal level to comply with the guidelines.

4. Set to the maximum power setting and enable the EUT transmit continuously.

5. Use the following spectrum analyzer settings:

① Span shall wide enough to fully capture the emission being measured;

② Set RBW=100 kHz for $f < 1$ GHz, RBW=1MHz for $f > 1$ GHz ; VBW \geq RBW; Sweep = auto;

Detector function = peak; Trace = max hold for peak;

③ For average measurement: use duty cycle correction factor method per 15.35(c).

Duty cycle = On time/100 milliseconds

On time = $N1*L1+N2*L2+...+Nn-1*Ln-1+Nn*Ln$

Where N1 is number of type 1 pulses, L1 is length of type 1 pulses, etc.

Average Emission Level = Peak Emission Level + $20*\log(\text{Duty cycle})$

6. Corrected Reading: Antenna Factor + Cable Loss + Read Level - Pre-amp Factor = Level

7. For testing below 1GHz, if the emission level of the EUT in peak mode was 3 dB lower than the limit specified, then peak values of EUT will be reported, otherwise, the emissions will be repeated one by one using the CISPR quasi-peak method and reported.

8. For testing above 1GHz, the emission level of the EUT in peak mode was 20dB lower than peak limit (that means the emission level in average mode also complies with the limit in average mode), then peak values of EUT will be reported, otherwise, the emissions will be measured in average mode again and reported.

Remark:

The average levels were calculated from the peak level corrected with duty cycle correction factor (-24.70dB) derived from $20\log(\text{dwell time}/100\text{ms})$. This correction is only for signals that hop with the fundamental signal, such as band-edge and harmonic. Other spurious signals that are independent of the hopping signal would not use this correction.

3.8.3. Test Setup

3.8.3.1. For radiated emissions below 30MHz

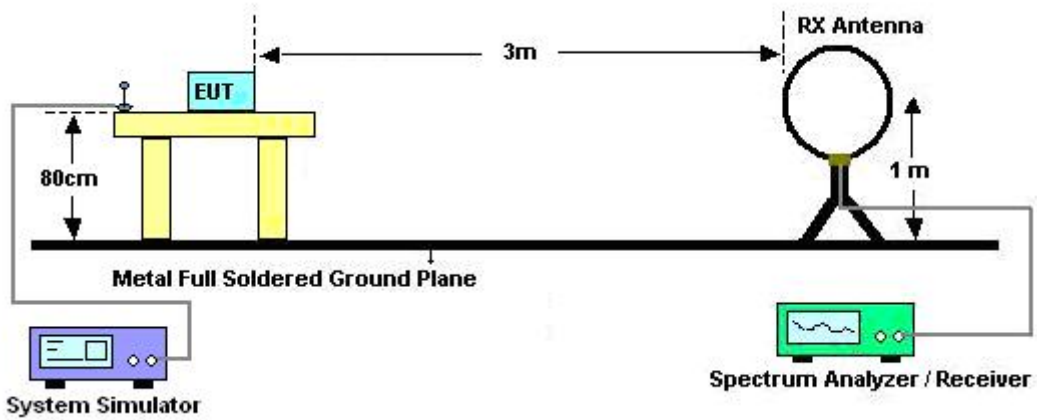

3.8.3.2. For radiated emissions from 30MHz to 1GHz

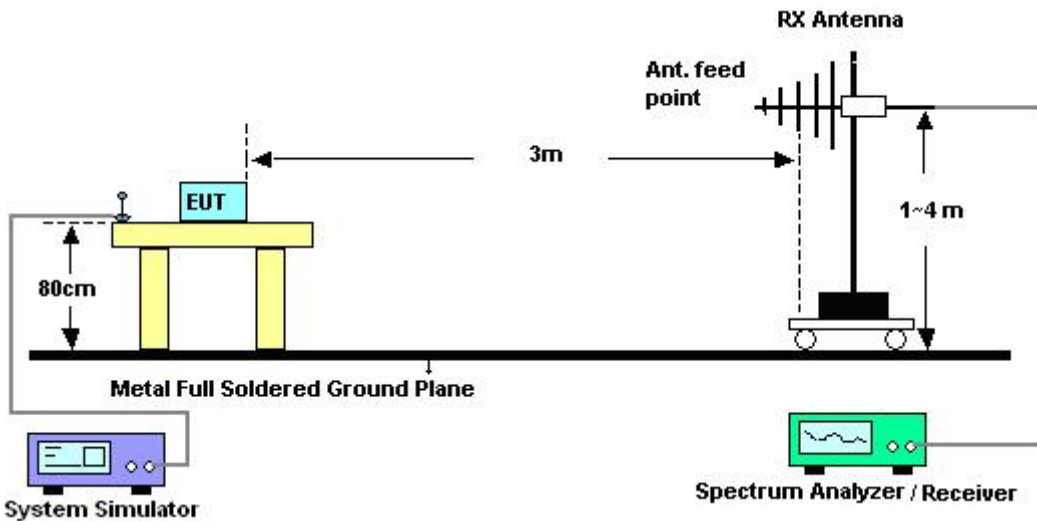

3.8.3.3. For radiated emissions above 1GHz

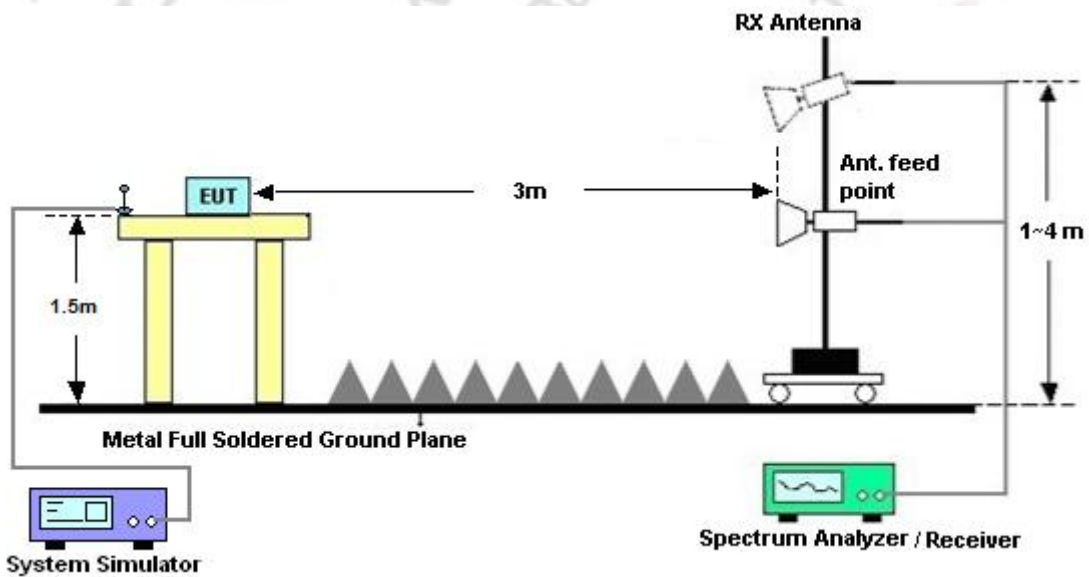

3.8.4. Test Result of Radiated Spurious Emission

For 9 kHz ~ 30 MHz

The low frequency, which started from 9 kHz to 30MHz, was pre-scanned and the result which was 20dB lower than the limit line was not reported.

For 30 MHz ~ 1 GHz:

Note:

All modes have been tested, only worst case(DH5_2402MHz)mode was recorded in the test report if no any others.

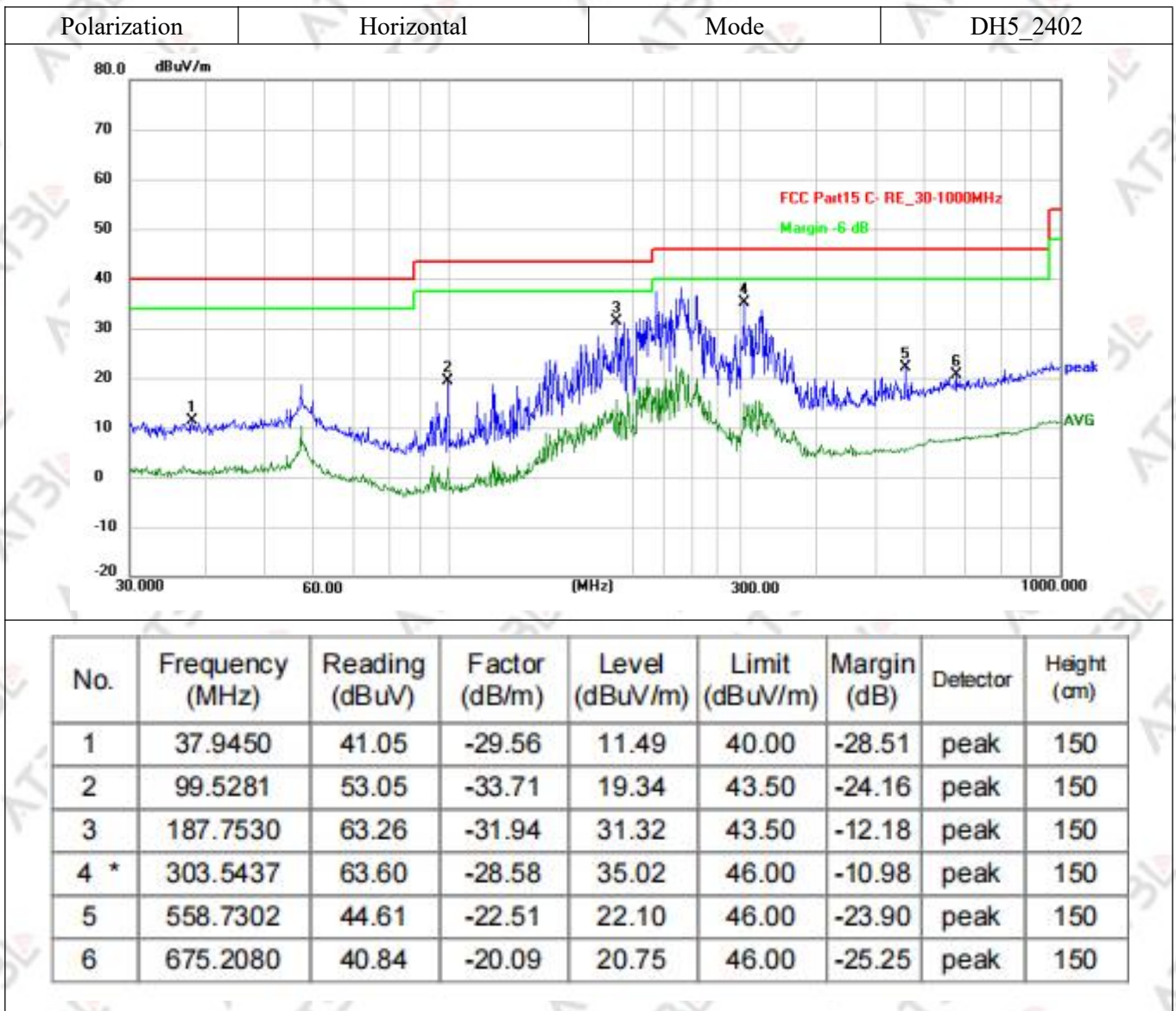

Polarization	Vertical	Mode	DH5_2402
--------------	----------	------	----------

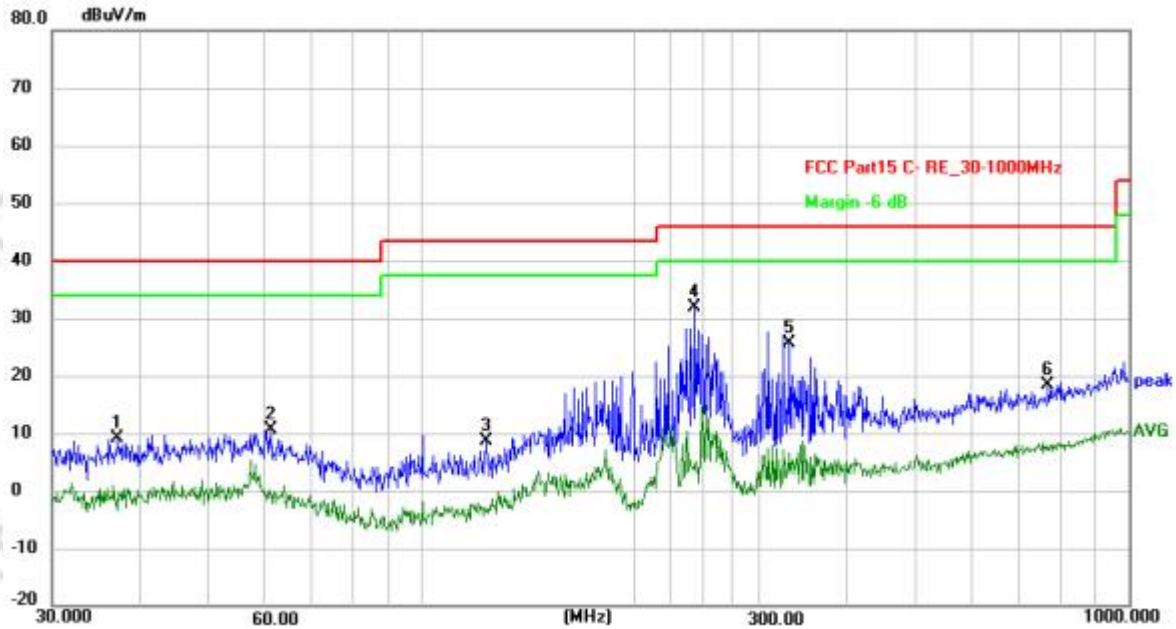

No.	Frequency (MHz)	Reading (dBuV)	Factor (dB/m)	Level (dBuV/m)	Limit (dBuV/m)	Margin (dB)	Detector	Height (cm)
1	37.1550	38.77	-29.55	9.22	40.00	-30.78	peak	150
2	61.1316	40.19	-29.54	10.65	40.00	-29.35	peak	150
3	123.2655	40.38	-31.77	8.61	43.50	-34.89	peak	150
4 *	243.3772	62.55	-30.63	31.92	46.00	-14.08	peak	150
5	331.3546	53.33	-27.72	25.61	46.00	-20.39	peak	150
6	768.7481	36.66	-18.24	18.42	46.00	-27.58	peak	150

For 1 GHz ~ 18GHz:

Note:

- 1.The all data rate modes had been test, but only worse test data was recorded in the test report.
- 2.In frequency ranges 18 ~25GHz no any other harmonic emissions detected which are tested to compliance with the limit. No recording in the test report. No any other emissions level which are attenuated less than 20dB below the limit. No recording in the test report.
- 3.We used the filter to test and the main frequency was filtered out.

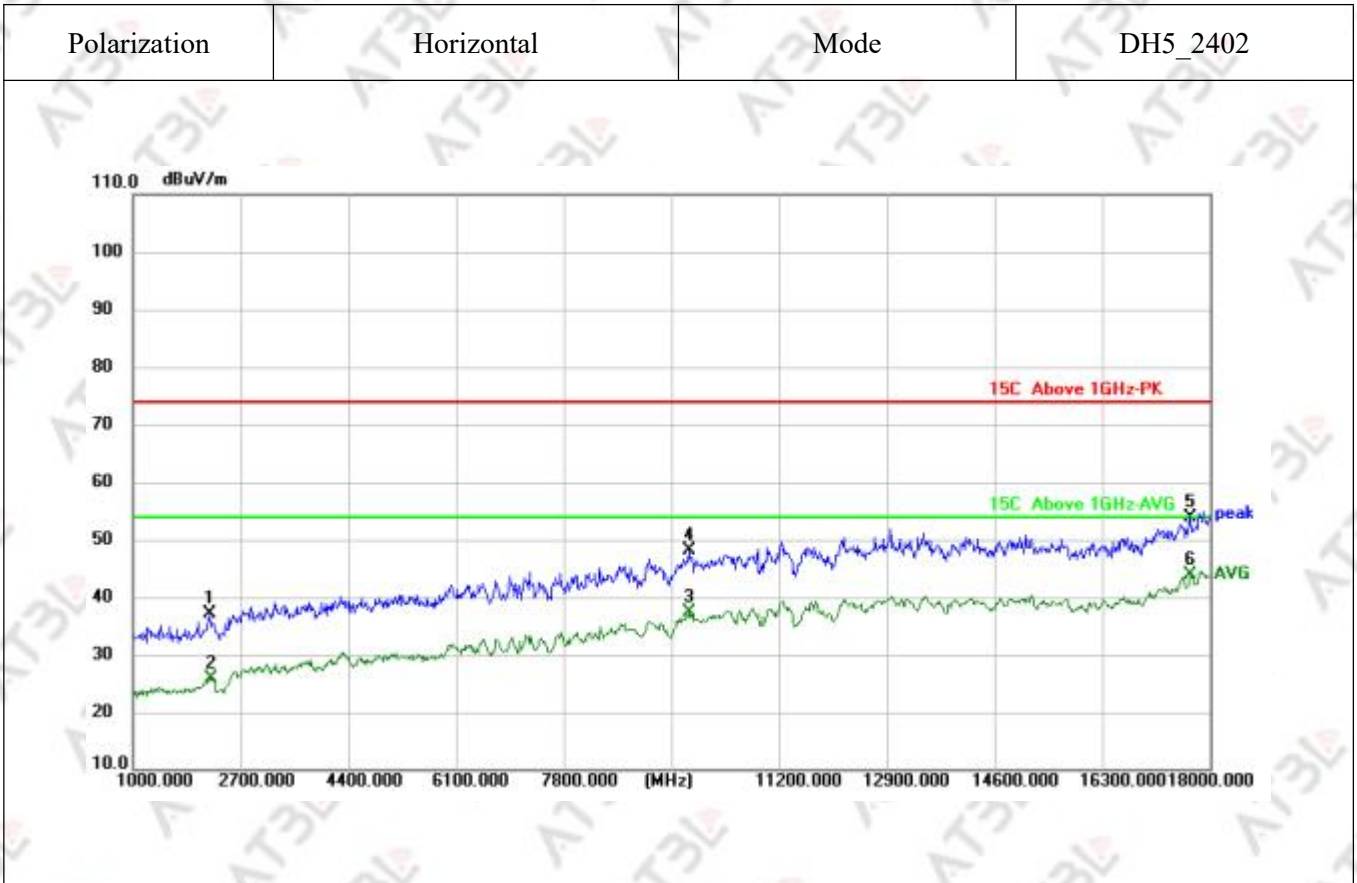

No.	Frequency (MHz)	Reading (dBuV)	Factor (dB/m)	Level (dBuV/m)	Limit (dBuV/m)	Margin (dB)	Detector
1	2207.000	52.80	-15.67	37.13	74.00	-36.87	peak
2	2241.000	41.43	-15.56	25.87	54.00	-28.13	AVG
3	9789.000	32.06	5.41	37.47	54.00	-16.53	AVG
4	9772.000	42.69	5.36	48.05	74.00	-25.95	peak
5	17694.000	36.62	17.35	53.97	74.00	-20.03	peak
6 *	17694.000	26.56	17.35	43.91	54.00	-10.09	AVG

Polarization	Vertical	Mode	DH5_2402
--------------	----------	------	----------

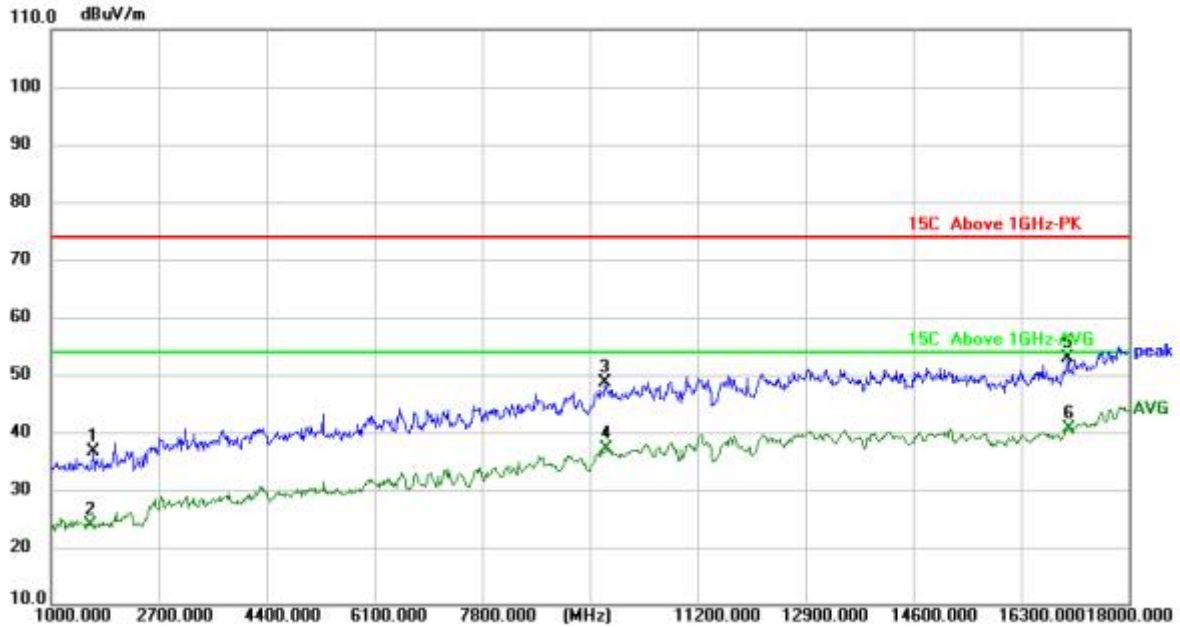

No.	Frequency (MHz)	Reading (dBuV)	Factor (dB/m)	Level (dBuV/m)	Limit (dBuV/m)	Margin (dB)	Detector
1	1663.000	55.03	-18.52	36.51	74.00	-37.49	peak
2	1629.000	42.63	-18.64	23.99	54.00	-30.01	AVG
3	9738.000	43.32	5.27	48.59	74.00	-25.41	peak
4	9755.000	31.86	5.32	37.18	54.00	-16.82	AVG
5	17031.000	39.23	13.59	52.82	74.00	-21.18	peak
6 *	17048.000	26.95	13.70	40.65	54.00	-13.35	AVG

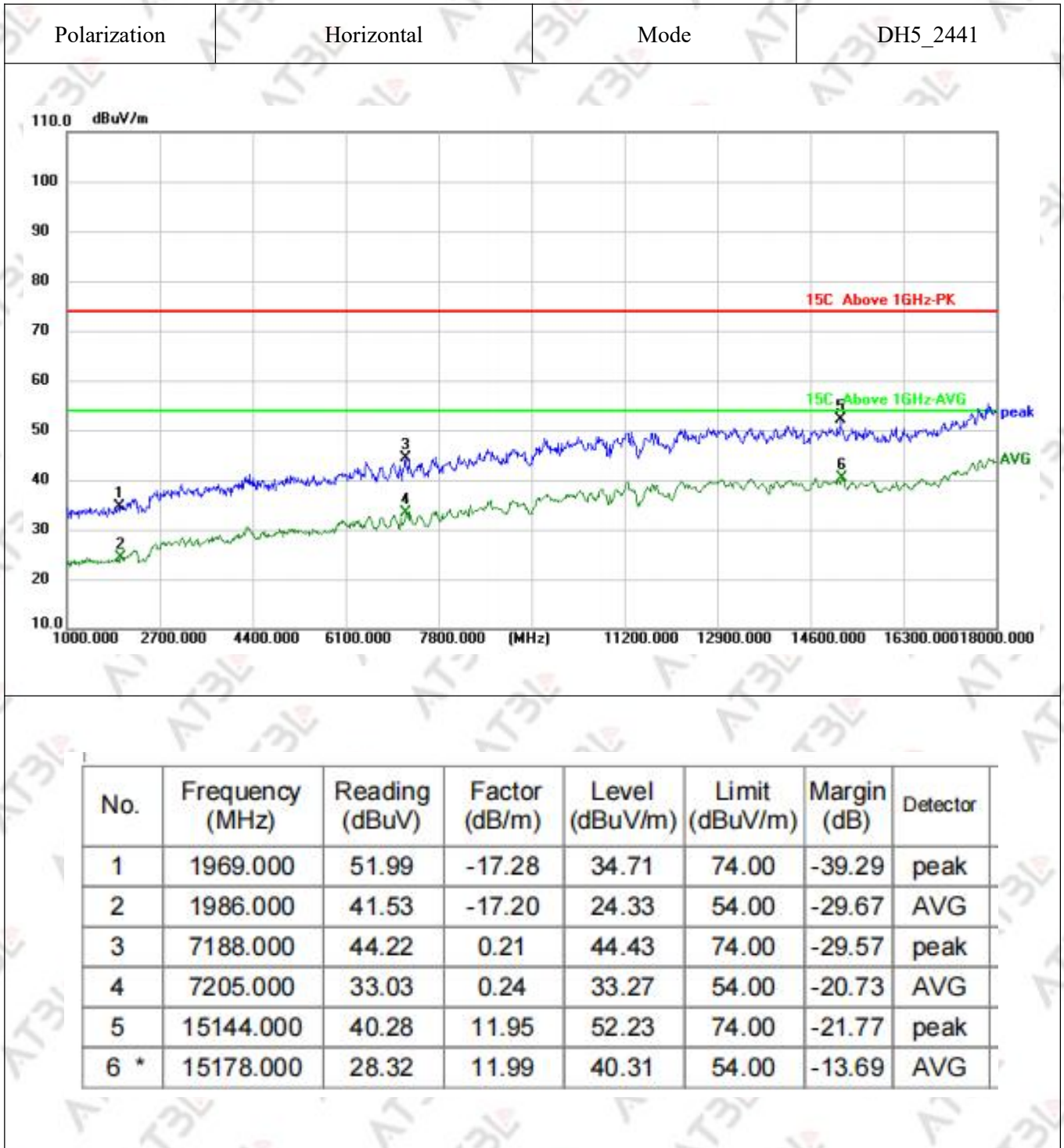

Polarization	Vertical	Mode	DH5_2441
--------------	----------	------	----------

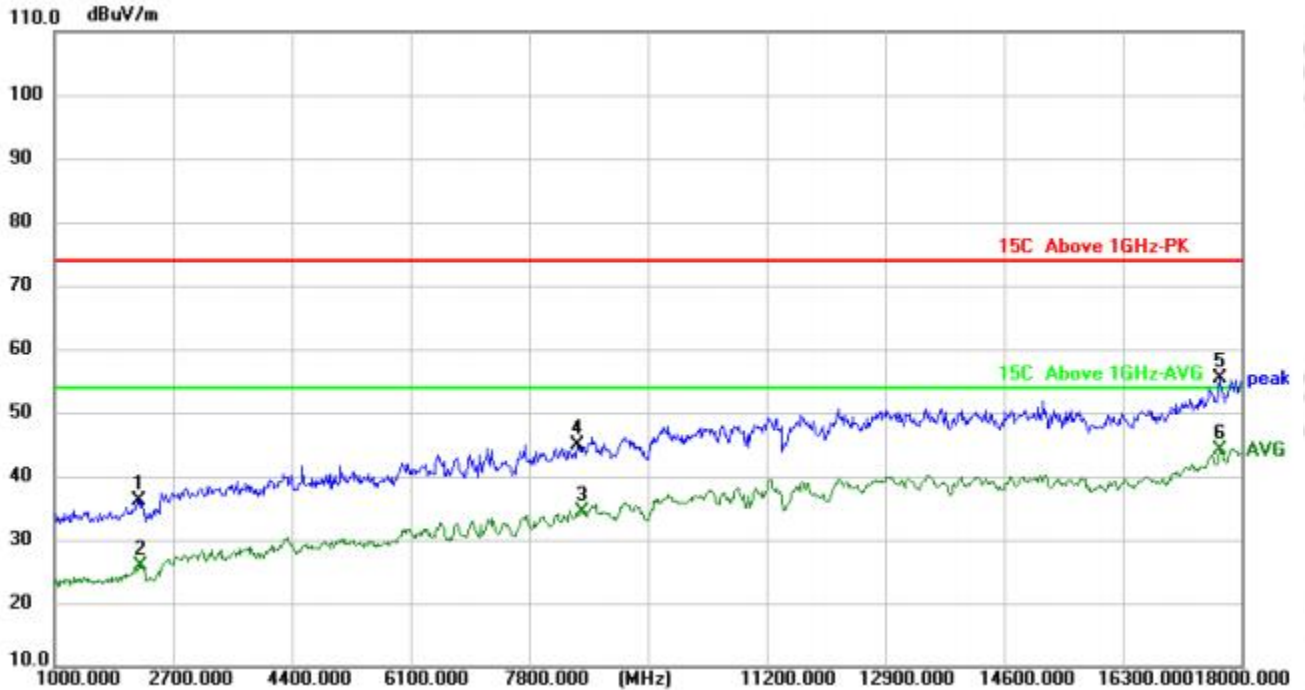

No.	Frequency (MHz)	Reading (dBuV)	Factor (dB/m)	Level (dBuV/m)	Limit (dBuV/m)	Margin (dB)	Detector
1	2207.000	51.89	-15.67	36.22	74.00	-37.78	peak
2	2241.000	41.42	-15.56	25.86	54.00	-28.14	AVG
3	8548.000	31.34	2.95	34.29	54.00	-19.71	AVG
4	8480.000	42.19	2.75	44.94	74.00	-29.06	peak
5	17694.000	37.92	17.35	55.27	74.00	-18.73	peak
6 *	17694.000	26.68	17.35	44.03	54.00	-9.97	AVG

Polarization	Horizontal	Mode	DH5_2480
--------------	------------	------	----------

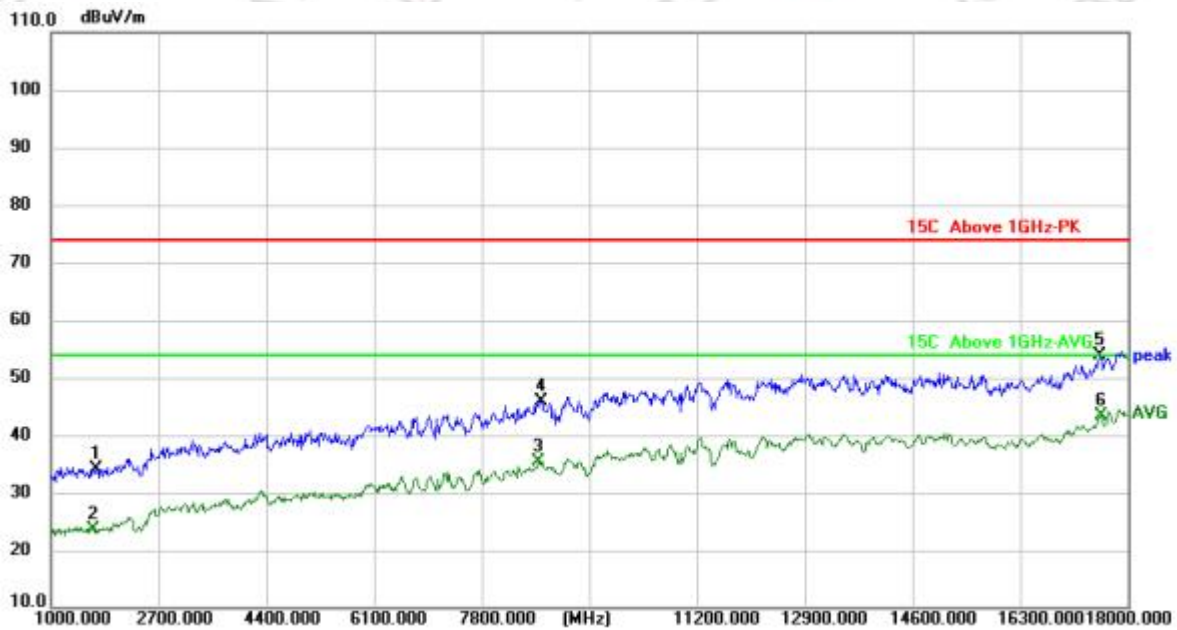

No.	Frequency (MHz)	Reading (dBuV)	Factor (dB/m)	Level (dBuV/m)	Limit (dBuV/m)	Margin (dB)	Detector
1	1714.000	52.49	-18.34	34.15	74.00	-39.85	peak
2	1663.000	42.21	-18.52	23.69	54.00	-30.31	AVG
3	8701.000	32.00	3.40	35.40	54.00	-18.60	AVG
4	8735.000	42.34	3.51	45.85	74.00	-28.15	peak
5	17558.000	37.00	16.76	53.76	74.00	-20.24	peak
6 *	17575.000	26.52	16.82	43.34	54.00	-10.66	AVG

Polarization	Vertical	Mode	DH5_2480
--------------	----------	------	----------

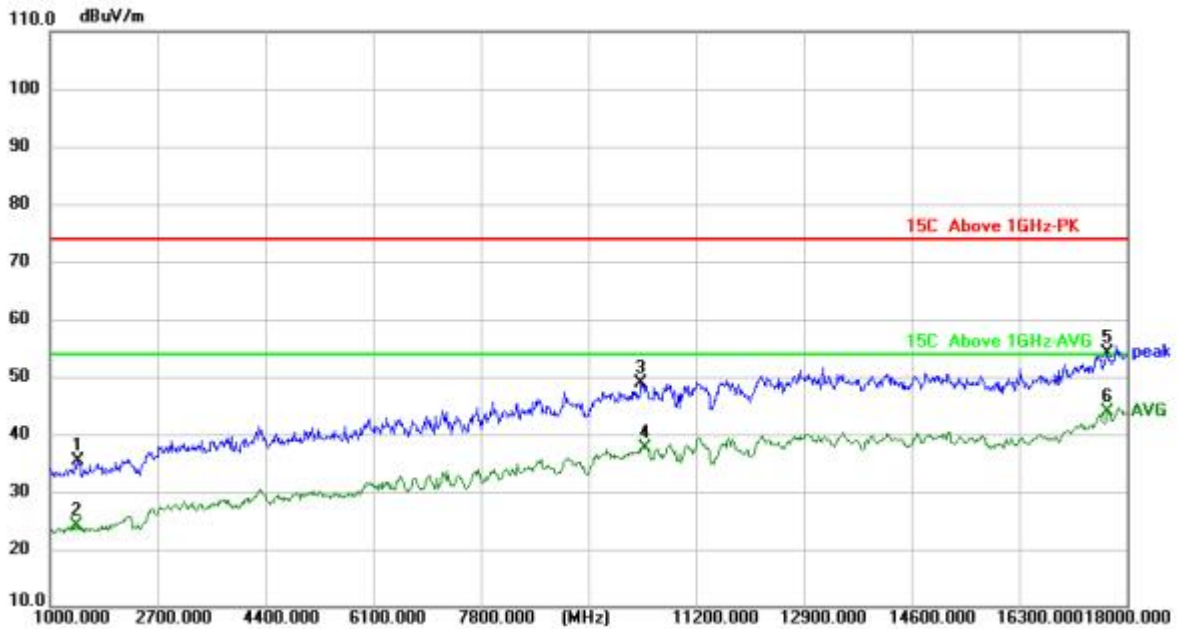

No.	Frequency (MHz)	Reading (dBuV)	Factor (dB/m)	Level (dBuV/m)	Limit (dBuV/m)	Margin (dB)	Detector
1	1442.000	54.09	-18.77	35.32	74.00	-38.68	peak
2	1408.000	42.94	-18.78	24.16	54.00	-29.84	AVG
3	10333.000	42.05	6.73	48.78	74.00	-25.22	peak
4	10384.000	30.88	6.84	37.72	54.00	-16.28	AVG
5	17694.000	36.74	17.35	54.09	74.00	-19.91	peak
6 *	17694.000	26.54	17.35	43.89	54.00	-10.11	AVG

Polarization	Horizontal	Mode	2DH5_2402
--------------	------------	------	-----------

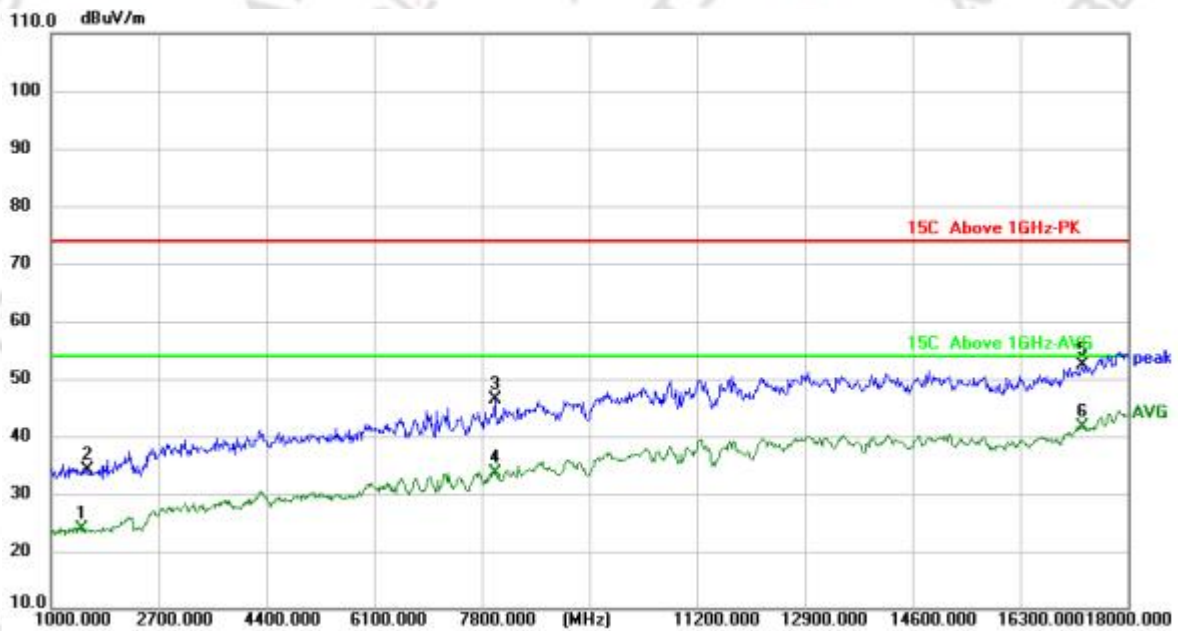

No.	Frequency (MHz)	Reading (dBuV)	Factor (dB/m)	Level (dBuV/m)	Limit (dBuV/m)	Margin (dB)	Detector
1	1493.000	42.65	-18.77	23.88	54.00	-30.12	AVG
2	1578.000	52.78	-18.74	34.04	74.00	-39.96	peak
3	8004.000	44.50	1.81	46.31	74.00	-27.69	peak
4	8004.000	31.85	1.81	33.66	54.00	-20.34	AVG
5	17286.000	37.16	15.18	52.34	74.00	-21.66	peak
6 *	17286.000	26.48	15.18	41.66	54.00	-12.34	AVG

Polarization	Vertical	Mode	2DH5_2402
--------------	----------	------	-----------

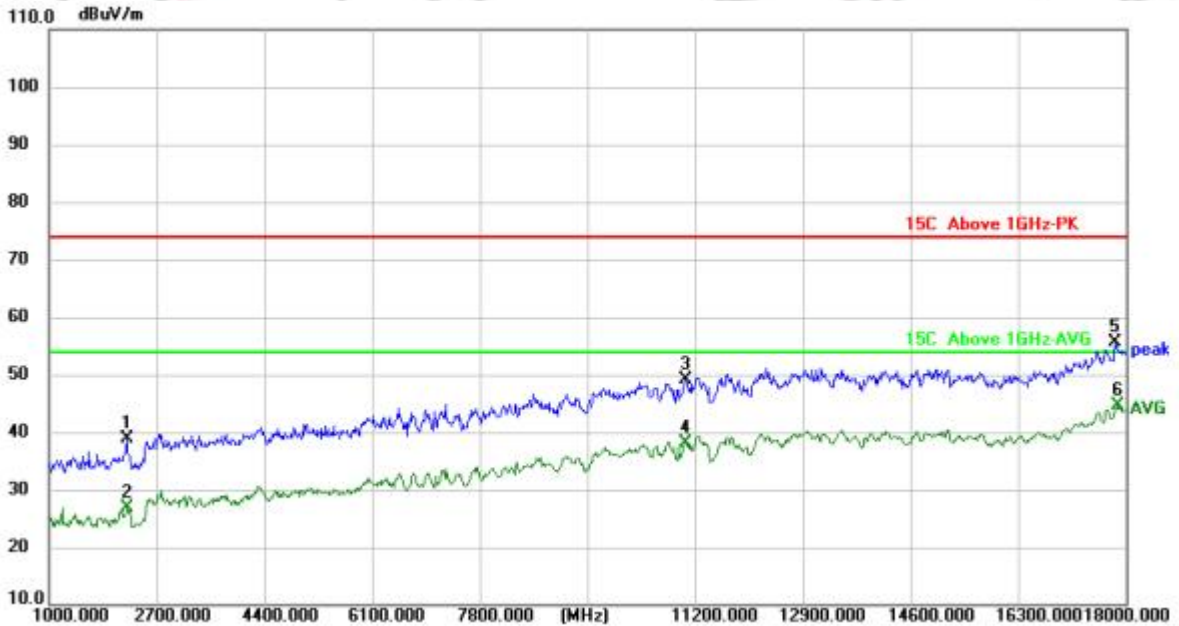

No.	Frequency (MHz)	Reading (dBuV)	Factor (dB/m)	Level (dBuV/m)	Limit (dBuV/m)	Margin (dB)
1	2224.000	54.43	-15.62	38.81	74.00	-35.19
2	2241.000	42.40	-15.56	26.84	54.00	-27.16
3	11047.000	41.21	7.97	49.18	74.00	-24.82
4	11047.000	30.18	7.97	38.15	54.00	-15.85
5	17830.000	37.57	17.95	55.52	74.00	-18.48
6 *	17864.000	26.50	18.09	44.59	54.00	-9.41

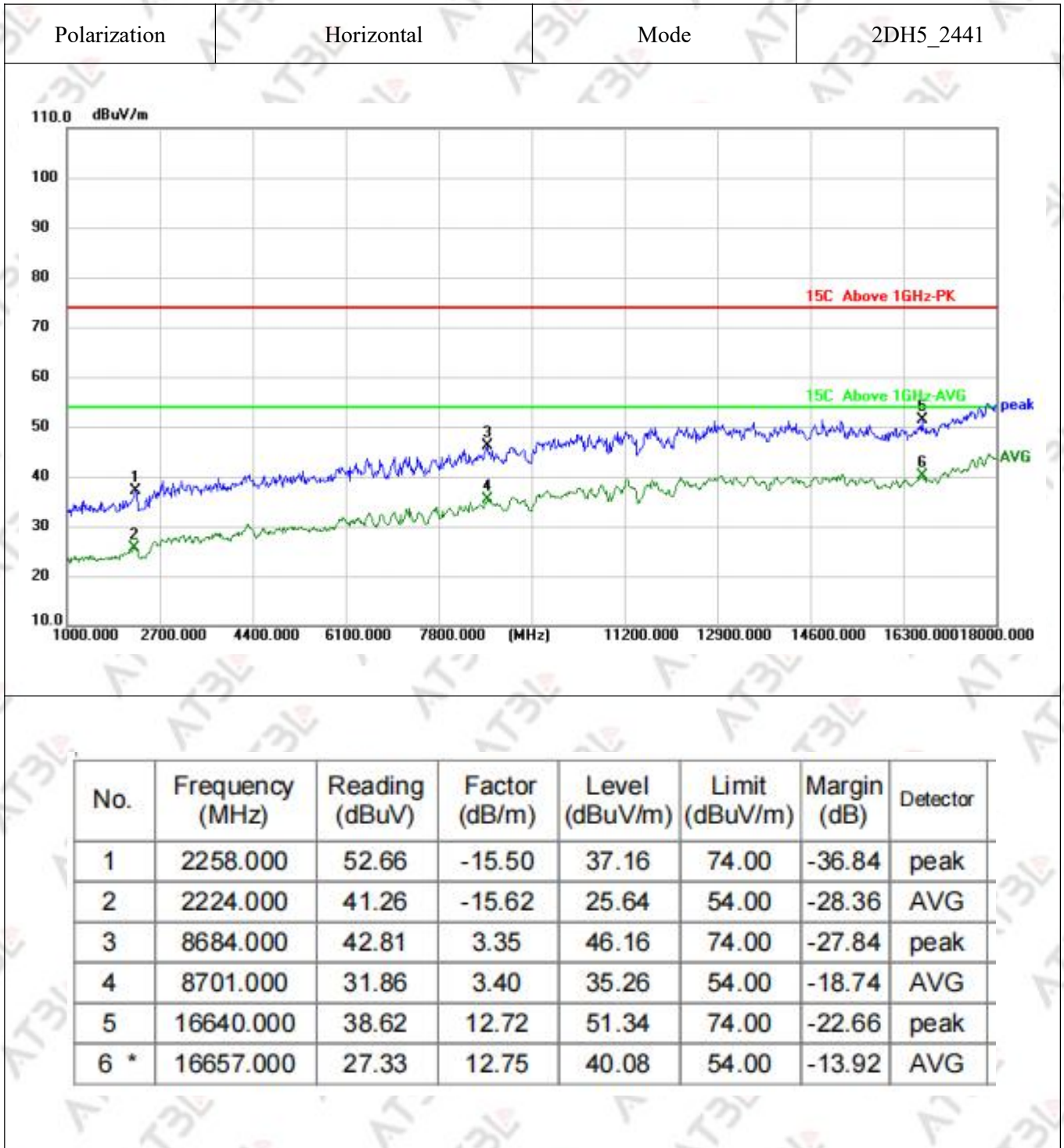

Polarization	Vertical	Mode	2DH5_2441
--------------	----------	------	-----------

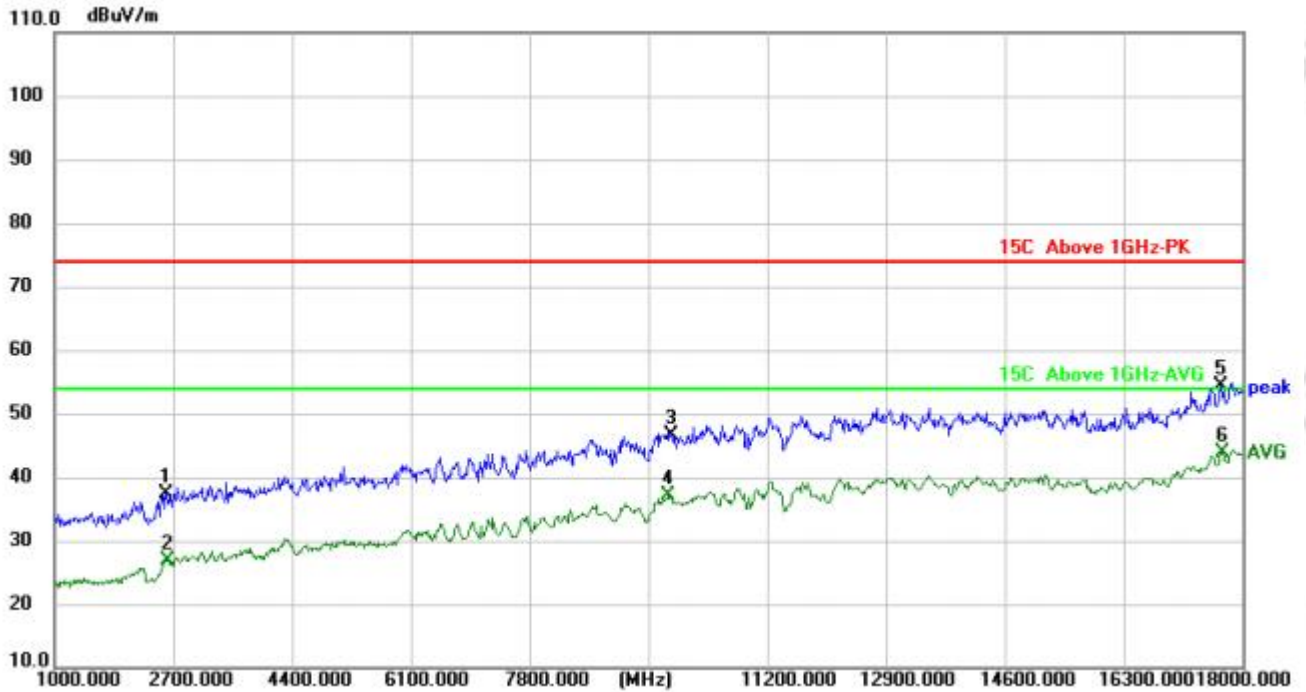

No.	Frequency (MHz)	Reading (dBuV)	Factor (dB/m)	Level (dBuV/m)	Limit (dBuV/m)	Margin (dB)	Detector
1	2598.000	51.49	-14.13	37.36	74.00	-36.64	peak
2	2615.000	40.95	-14.01	26.94	54.00	-27.06	AVG
3	9823.000	41.08	5.50	46.58	74.00	-27.42	peak
4	9789.000	31.81	5.41	37.22	54.00	-16.78	AVG
5	17694.000	37.00	17.35	54.35	74.00	-19.65	peak
6 *	17711.000	26.48	17.43	43.91	54.00	-10.09	AVG

Polarization	Horizontal	Mode	2DH5_2480
--------------	------------	------	-----------

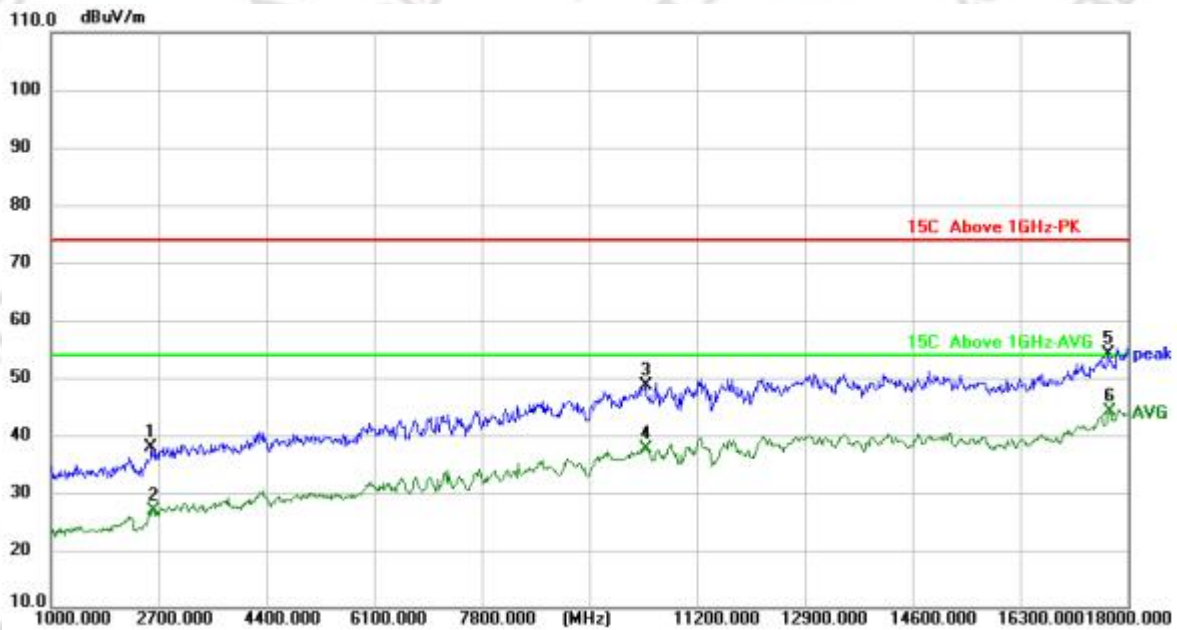

No.	Frequency (MHz)	Reading (dBuV)	Factor (dB/m)	Level (dBuV/m)	Limit (dBuV/m)	Margin (dB)	Detector
1	2581.000	52.11	-14.21	37.90	74.00	-36.10	peak
2	2615.000	40.94	-14.01	26.93	54.00	-27.07	AVG
3	10384.000	41.83	6.84	48.67	74.00	-25.33	peak
4	10384.000	30.76	6.84	37.60	54.00	-16.40	AVG
5	17694.000	36.83	17.35	54.18	74.00	-19.82	peak
6 *	17711.000	26.66	17.43	44.09	54.00	-9.91	AVG

Polarization	Vertical	Mode	2DH5_2480
--------------	----------	------	-----------

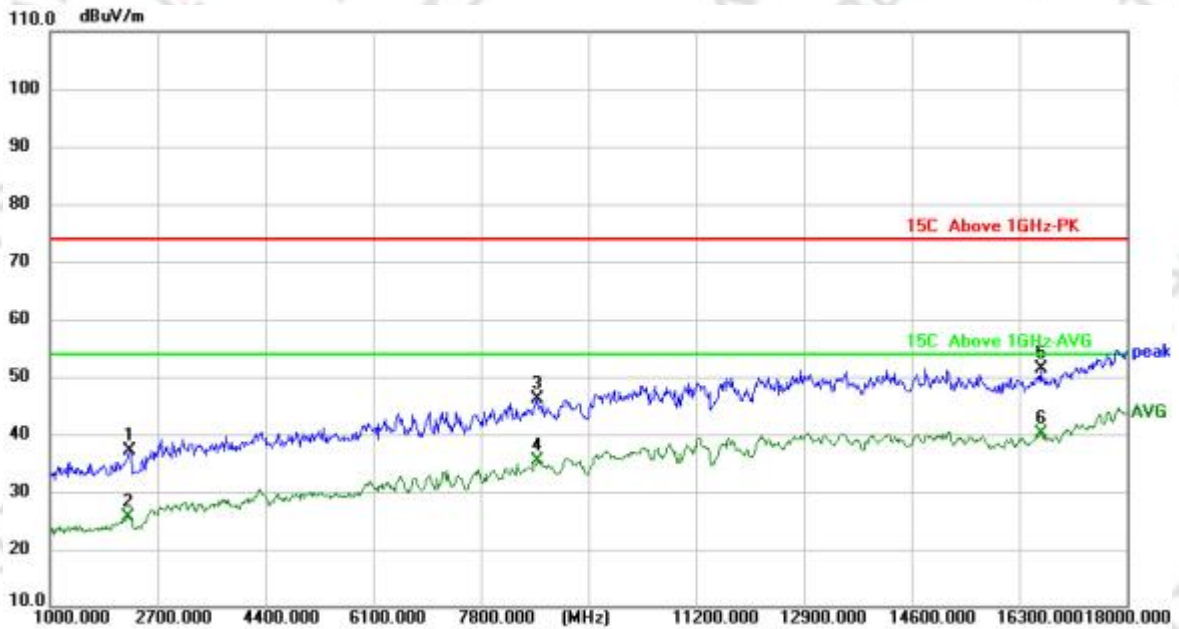

No.	Frequency (MHz)	Reading (dBuV)	Factor (dB/m)	Level (dBuV/m)	Limit (dBuV/m)	Margin (dB)	Detector
1	2258.000	52.66	-15.50	37.16	74.00	-36.84	peak
2	2224.000	41.26	-15.62	25.64	54.00	-28.36	AVG
3	8684.000	42.81	3.35	46.16	74.00	-27.84	peak
4	8701.000	31.86	3.40	35.26	54.00	-18.74	AVG
5	16640.000	38.62	12.72	51.34	74.00	-22.66	peak
6 *	16657.000	27.33	12.75	40.08	54.00	-13.92	AVG

Polarization	Horizontal	Mode	3DH5_2402
--------------	------------	------	-----------

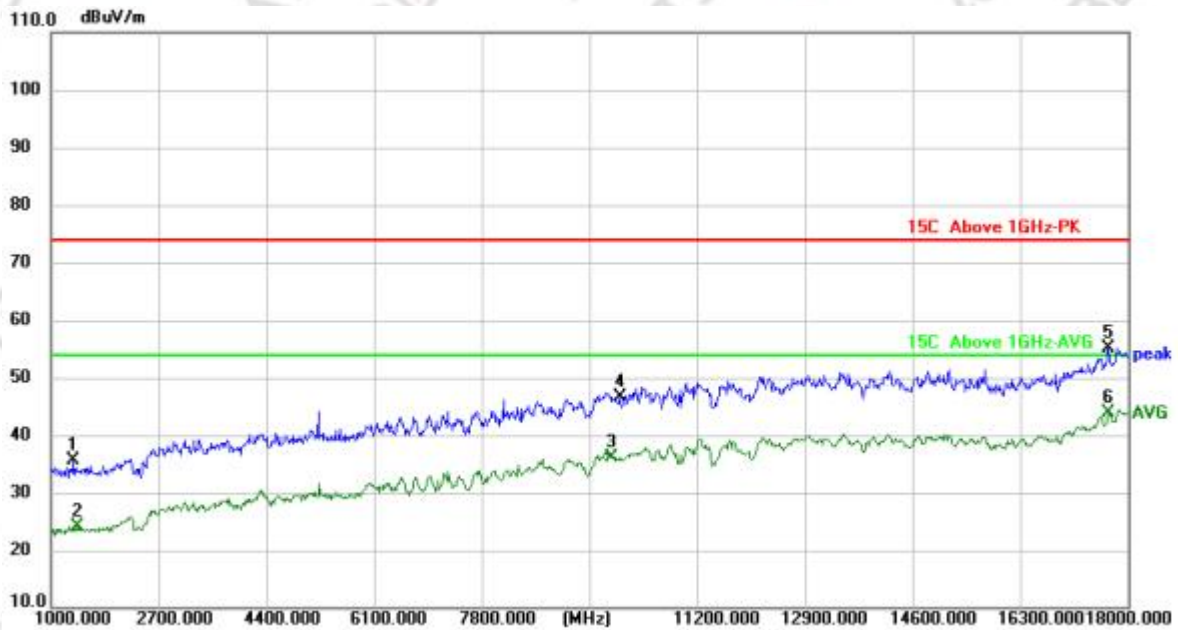

No.	Frequency (MHz)	Reading (dBuV)	Factor (dB/m)	Level (dBuV/m)	Limit (dBuV/m)	Margin (dB)	Detector
1	1357.000	54.49	-18.90	35.59	74.00	-38.41	peak
2	1408.000	43.02	-18.78	24.24	54.00	-29.76	AVG
3	9840.000	30.66	5.56	36.22	54.00	-17.78	AVG
4	9976.000	40.76	5.94	46.70	74.00	-27.30	peak
5	17694.000	37.73	17.35	55.08	74.00	-18.92	peak
6 *	17694.000	26.58	17.35	43.93	54.00	-10.07	AVG

Polarization	Vertical	Mode	3DH5_2402
--------------	----------	------	-----------

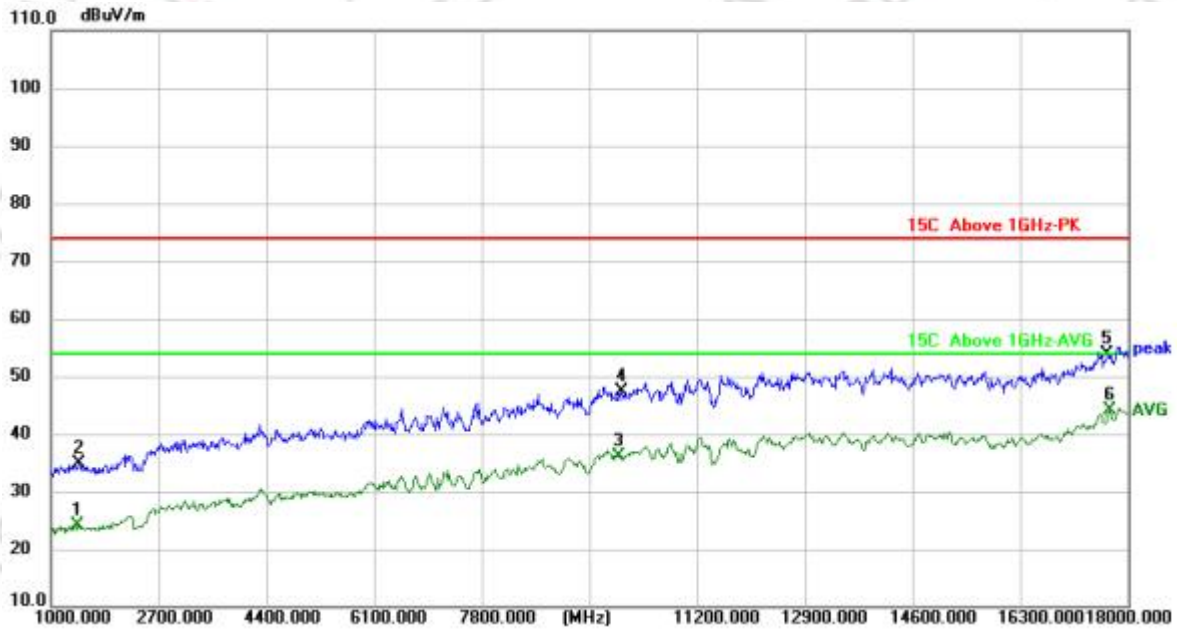

No.	Frequency (MHz)	Reading (dBuV)	Factor (dB/m)	Level (dBuV/m)	Limit (dBuV/m)	Margin (dB)	Detector
1	1408.000	43.02	-18.78	24.24	54.00	-29.76	AVG
2	1442.000	53.58	-18.77	34.81	74.00	-39.19	peak
3	9959.000	30.27	5.88	36.15	54.00	-17.85	AVG
4	10010.000	41.39	6.03	47.42	74.00	-26.58	peak
5	17677.000	36.69	17.28	53.97	74.00	-20.03	peak
6 *	17711.000	26.65	17.43	44.08	54.00	-9.92	AVG

Polarization	Horizontal	Mode	3DH5_2441
--------------	------------	------	-----------

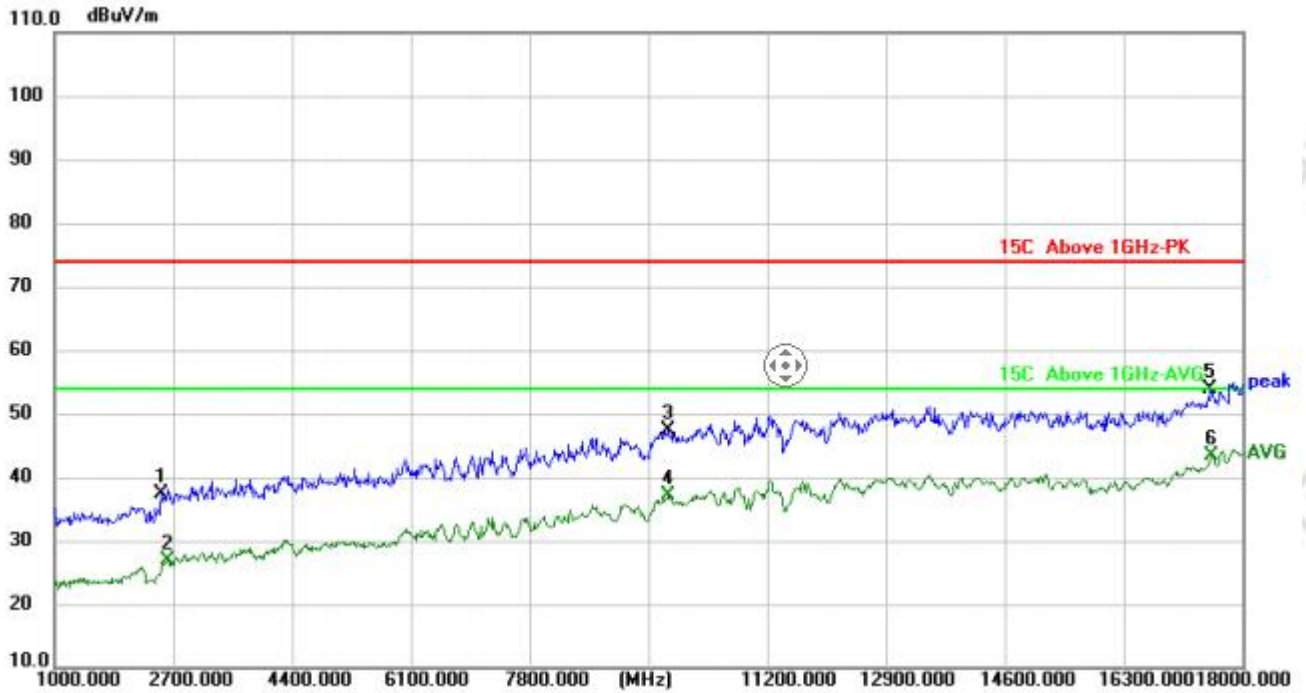

No.	Frequency (MHz)	Reading (dBuV)	Factor (dB/m)	Level (dBuV/m)	Limit (dBuV/m)	Margin (dB)	Detector
1	2530.000	51.72	-14.45	37.27	74.00	-36.73	peak
2	2615.000	40.94	-14.01	26.93	54.00	-27.07	AVG
3	9772.000	42.02	5.36	47.38	74.00	-26.62	peak
4	9789.000	31.69	5.41	37.10	54.00	-16.90	AVG
5	17541.000	37.25	16.68	53.93	74.00	-20.07	peak
6 *	17558.000	26.73	16.76	43.49	54.00	-10.51	AVG

Polarization	Vertical	Mode	3DH5_2441
--------------	----------	------	-----------

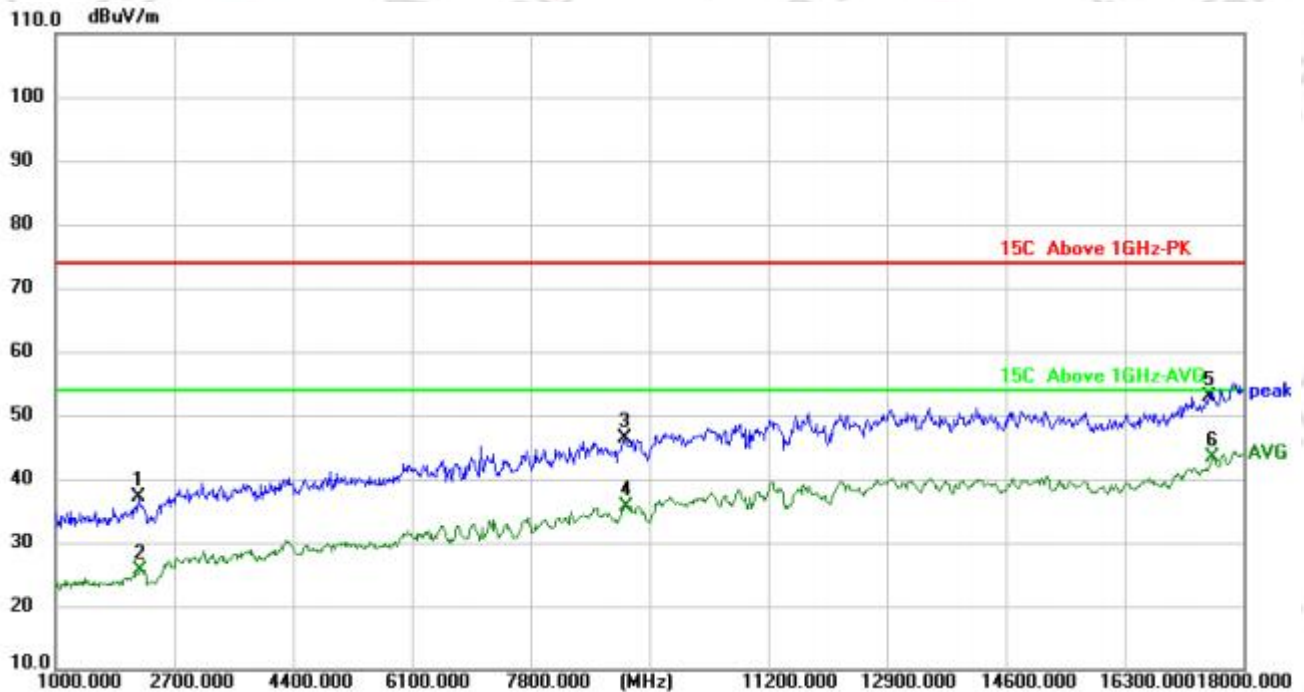

No.	Frequency (MHz)	Reading (dBuV)	Factor (dB/m)	Level (dBuV/m)	Limit (dBuV/m)	Margin (dB)	Detector
1	2190.000	52.77	-15.76	37.01	74.00	-36.99	peak
2	2207.000	41.39	-15.67	25.72	54.00	-28.28	AVG
3	9143.000	41.97	4.38	46.35	74.00	-27.65	peak
4	9177.000	31.29	4.41	35.70	54.00	-18.30	AVG
5	17507.000	36.35	16.54	52.89	74.00	-21.11	peak
6 *	17558.000	26.67	16.76	43.43	54.00	-10.57	AVG

Polarization	Horizontal	Mode	3DH5_2480
--------------	------------	------	-----------

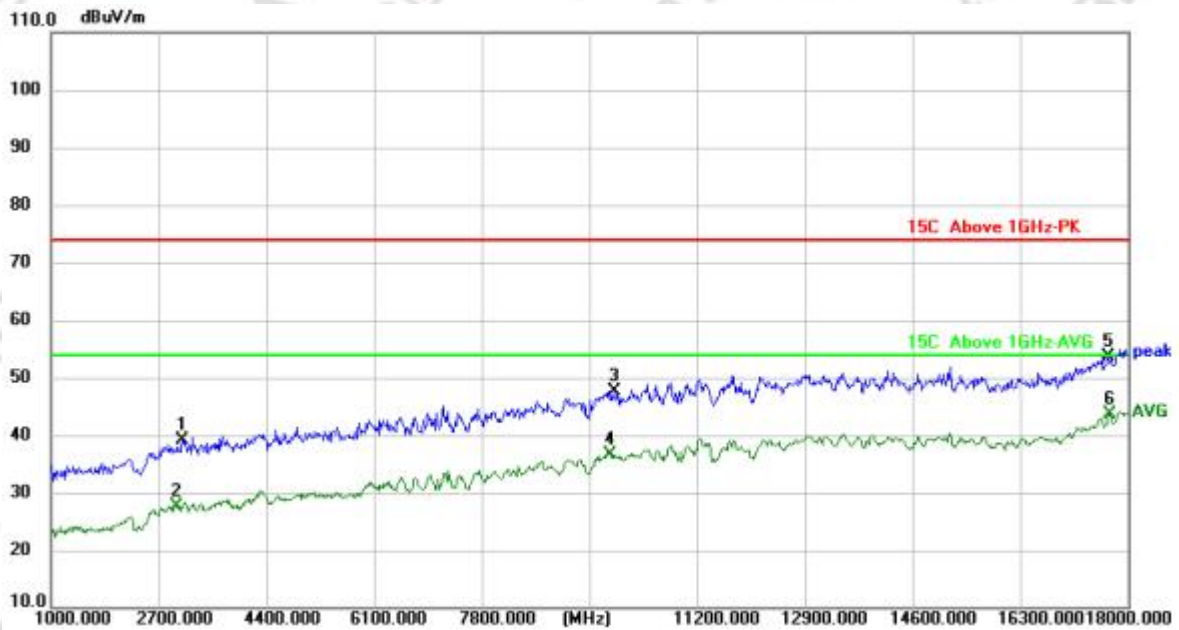

No.	Frequency (MHz)	Reading (dBuV)	Factor (dB/m)	Level (dBuV/m)	Limit (dBuV/m)	Margin (dB)	Detector
1	3074.000	50.97	-11.76	39.21	74.00	-34.79	peak
2	2989.000	39.68	-11.98	27.70	54.00	-26.30	AVG
3	9891.000	41.85	5.70	47.55	74.00	-26.45	peak
4	9823.000	31.23	5.50	36.73	54.00	-17.27	AVG
5	17694.000	36.32	17.35	53.67	74.00	-20.33	peak
6 *	17711.000	26.26	17.43	43.69	54.00	-10.31	AVG

Polarization	Vertical	Mode	3DH5_2480
--------------	----------	------	-----------

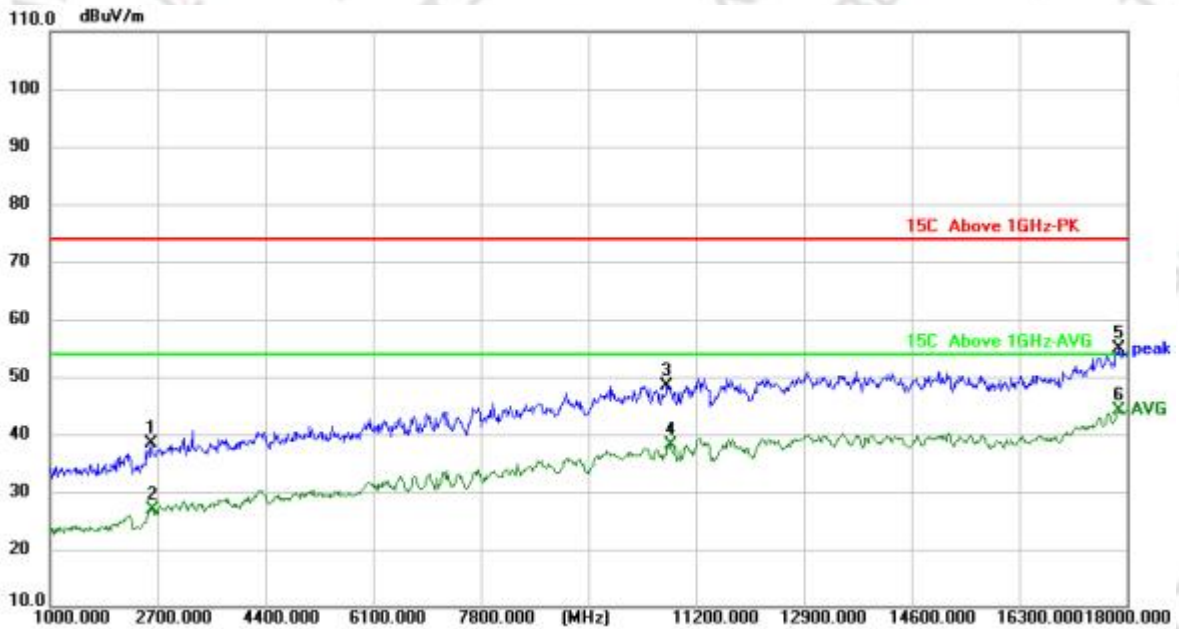

No.	Frequency (MHz)	Reading (dBuV)	Factor (dB/m)	Level (dBuV/m)	Limit (dBuV/m)	Margin (dB)	Detector
1	2598.000	52.61	-14.13	38.48	74.00	-35.52	peak
2	2615.000	40.98	-14.01	26.97	54.00	-27.03	AVG
3	10741.000	40.89	7.49	48.38	74.00	-25.62	peak
4	10792.000	30.52	7.57	38.09	54.00	-15.91	AVG
5	17864.000	36.81	18.09	54.90	74.00	-19.10	peak
6 *	17864.000	26.04	18.09	44.13	54.00	-9.87	AVG

3.8.5. Test Result of Restricted Band

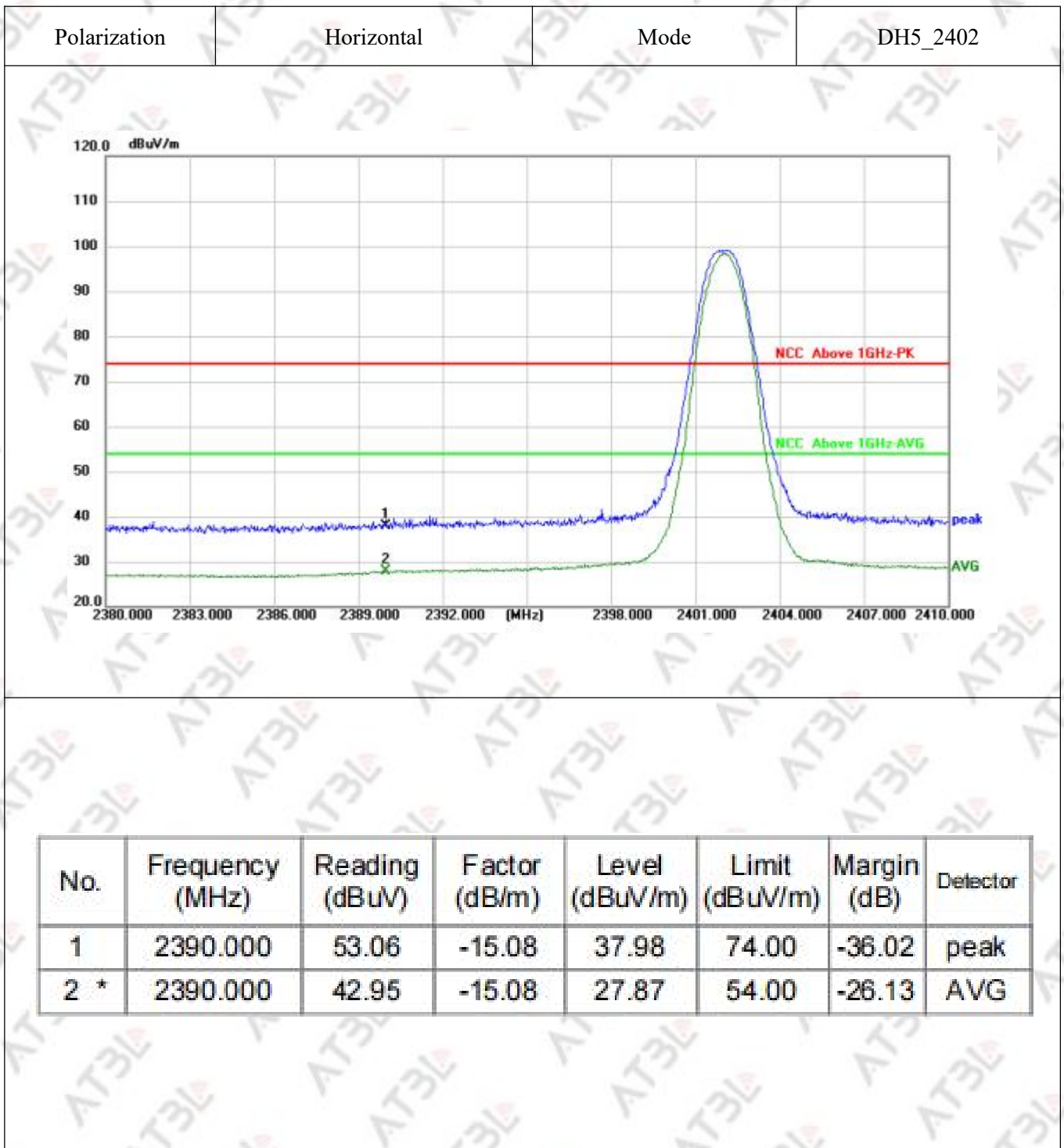

Polarization	Vertical	Mode	DH5_2402
--------------	----------	------	----------

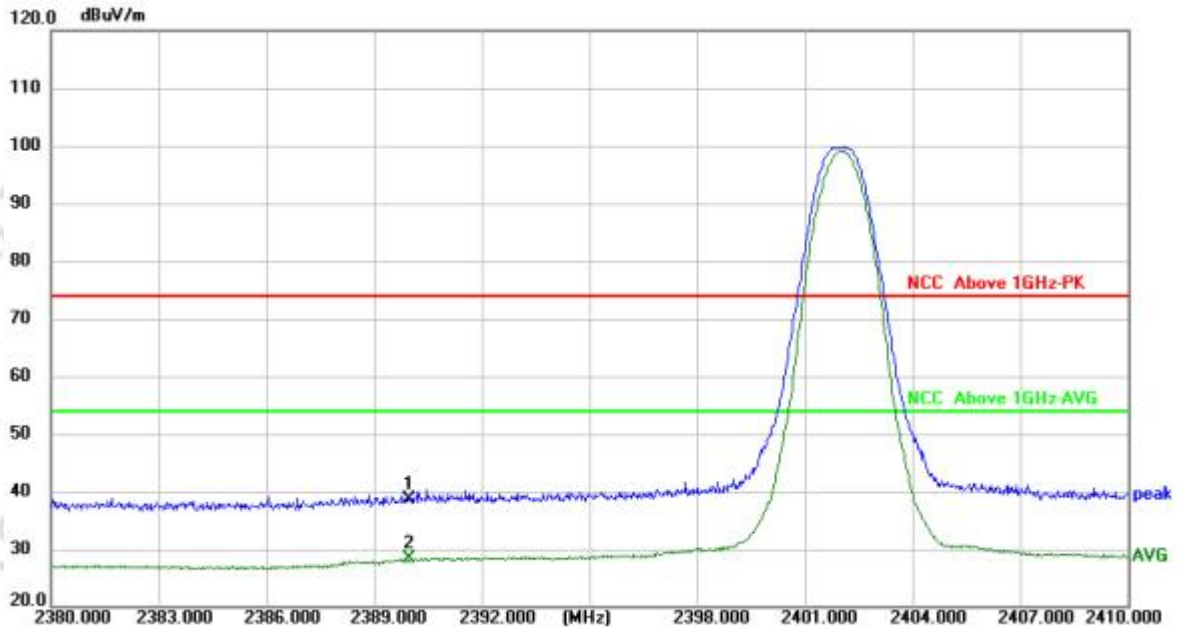

No.	Frequency (MHz)	Reading (dBuV)	Factor (dB/m)	Level (dBuV/m)	Limit (dBuV/m)	Margin (dB)	Detector
1	2390.000	53.81	-15.08	38.73	74.00	-35.27	peak
2 *	2390.000	43.39	-15.08	28.31	54.00	-25.69	AVG

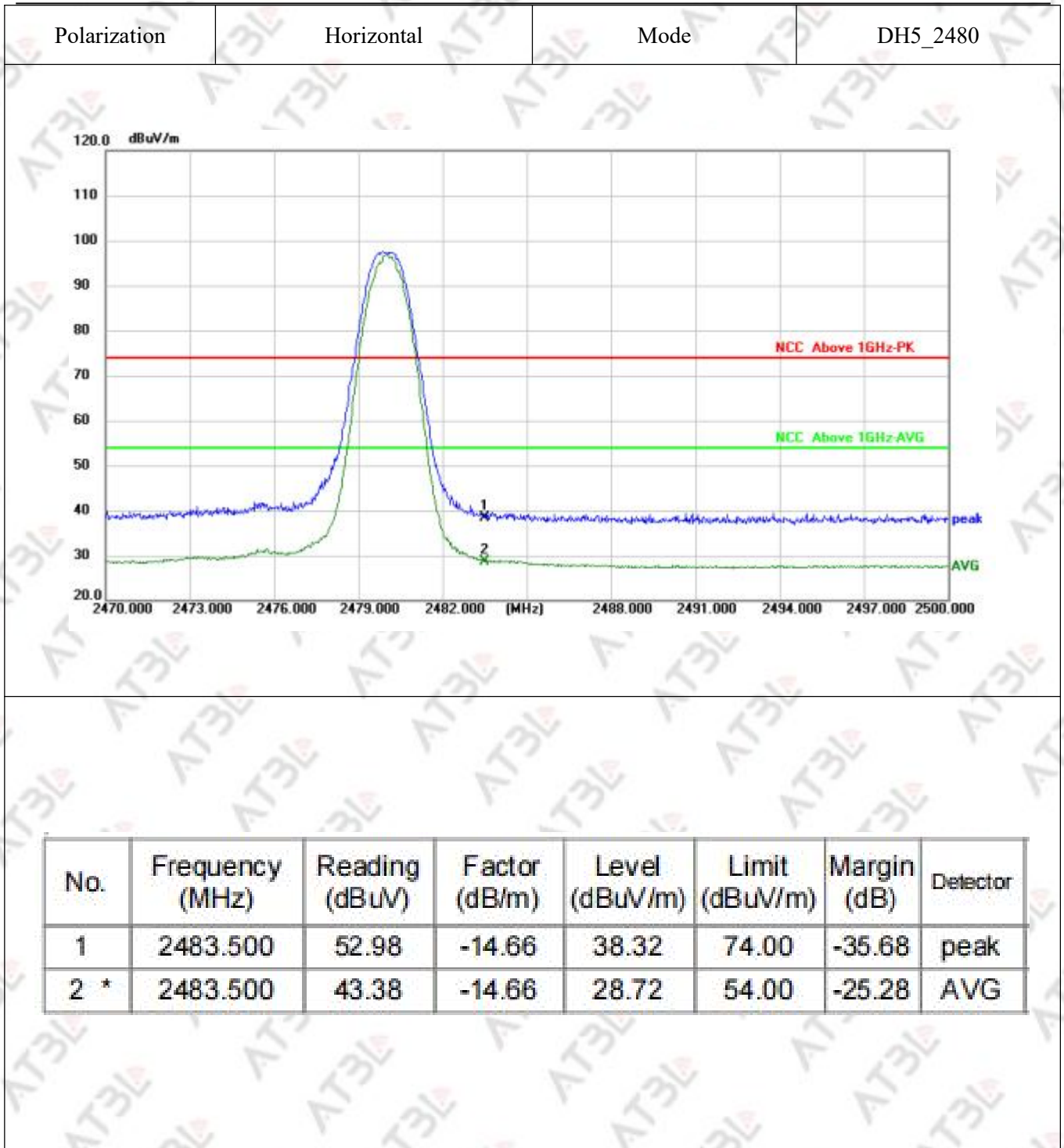

Polarization	Vertical	Mode	DH5_2480
--------------	----------	------	----------

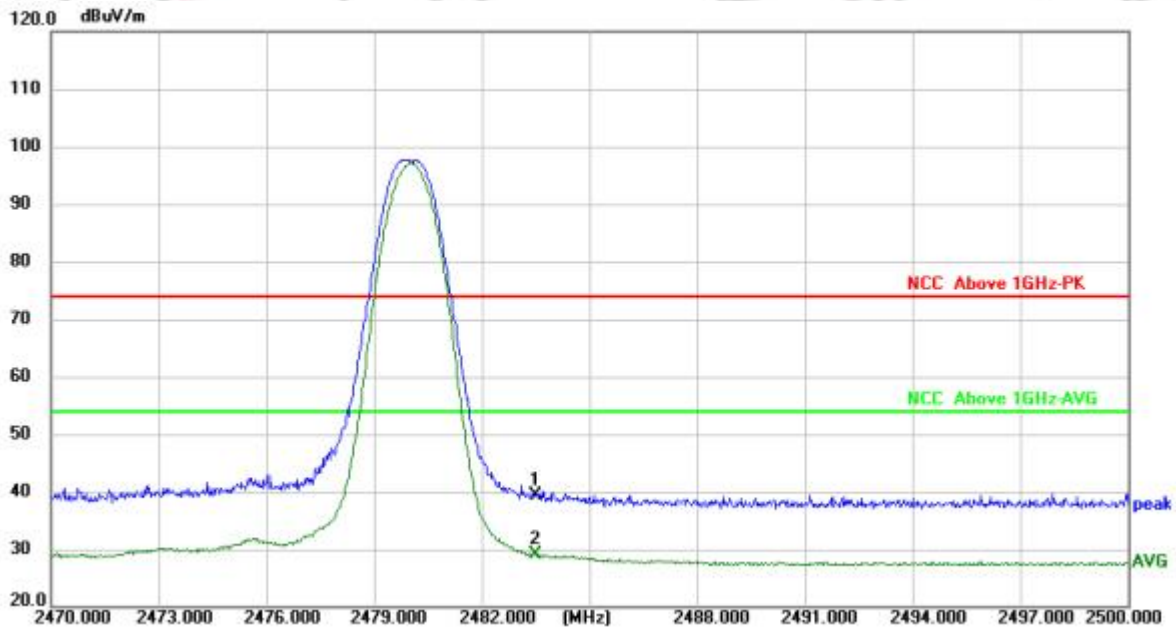

No.	Frequency (MHz)	Reading (dBuV)	Factor (dB/m)	Level (dBuV/m)	Limit (dBuV/m)	Margin (dB)	Detector
1	2483.500	54.13	-14.66	39.47	74.00	-34.53	peak
2 *	2483.500	43.72	-14.66	29.06	54.00	-24.94	AVG

Polarization	Horizontal	Mode	2DH5_2402
--------------	------------	------	-----------

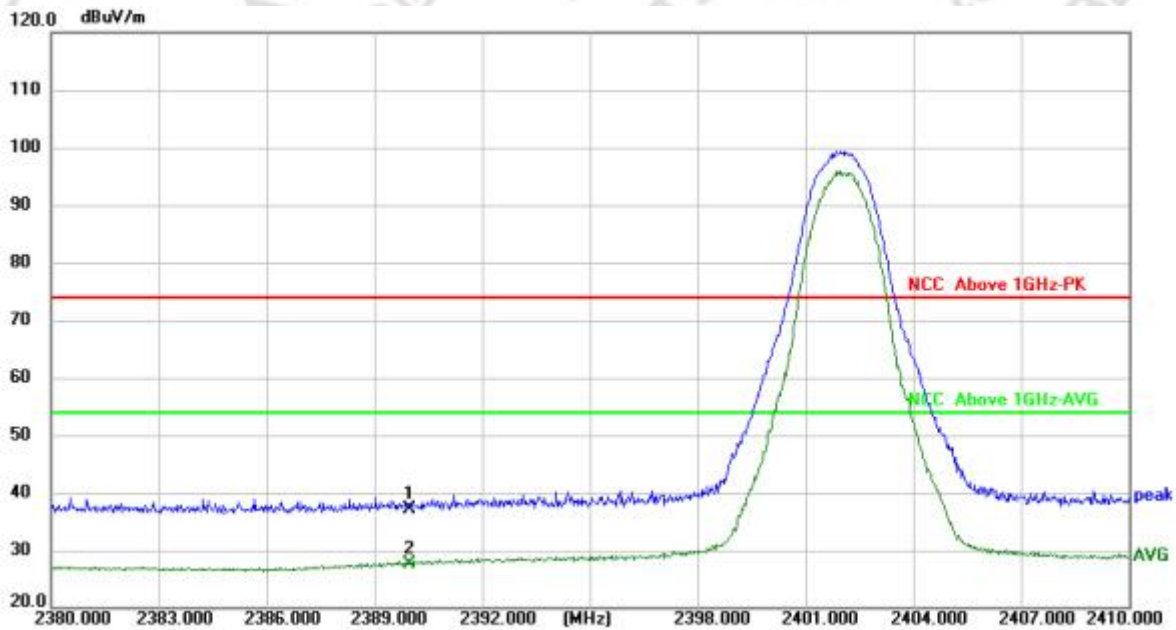

No.	Frequency (MHz)	Reading (dBuV)	Factor (dB/m)	Level (dBuV/m)	Limit (dBuV/m)	Margin (dB)	Detector
1	2390.000	52.15	-15.08	37.07	74.00	-36.93	peak
2 *	2390.000	42.74	-15.08	27.66	54.00	-26.34	AVG

Polarization	Vertical	Mode	2DH5_2402
--------------	----------	------	-----------

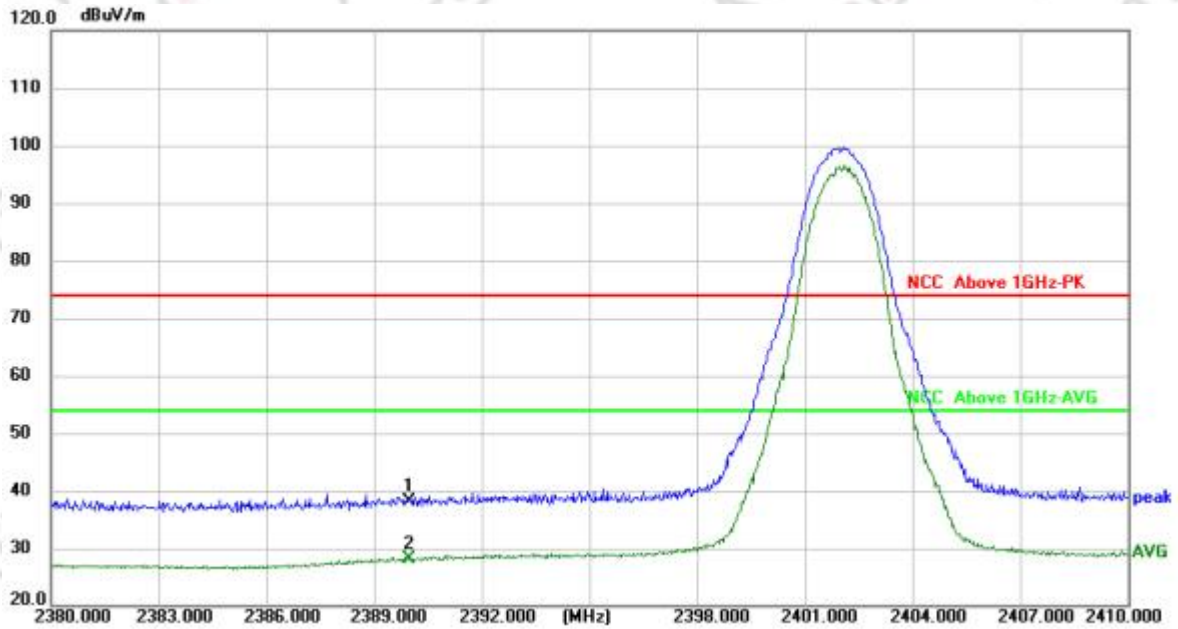

No.	Frequency (MHz)	Reading (dBuV)	Factor (dB/m)	Level (dBuV/m)	Limit (dBuV/m)	Margin (dB)	Detector
1	2390.000	53.09	-15.08	38.01	74.00	-35.99	peak
2 *	2390.000	43.18	-15.08	28.10	54.00	-25.90	AVG

Polarization	Horizontal	Mode	2DH5_2480
--------------	------------	------	-----------

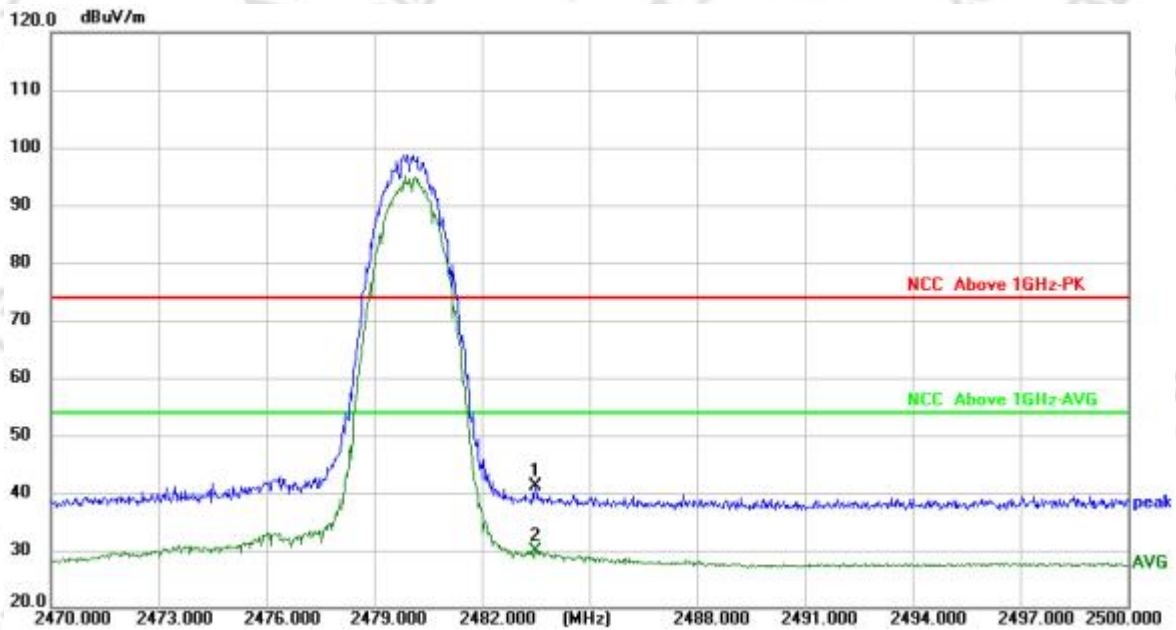

No.	Frequency (MHz)	Reading (dBuV)	Factor (dB/m)	Level (dBuV/m)	Limit (dBuV/m)	Margin (dB)	Detector
1	2483.500	55.85	-14.66	41.19	74.00	-32.81	peak
2 *	2483.500	44.43	-14.66	29.77	54.00	-24.23	AVG

Polarization	Vertical	Mode	2DH5_2480
--------------	----------	------	-----------

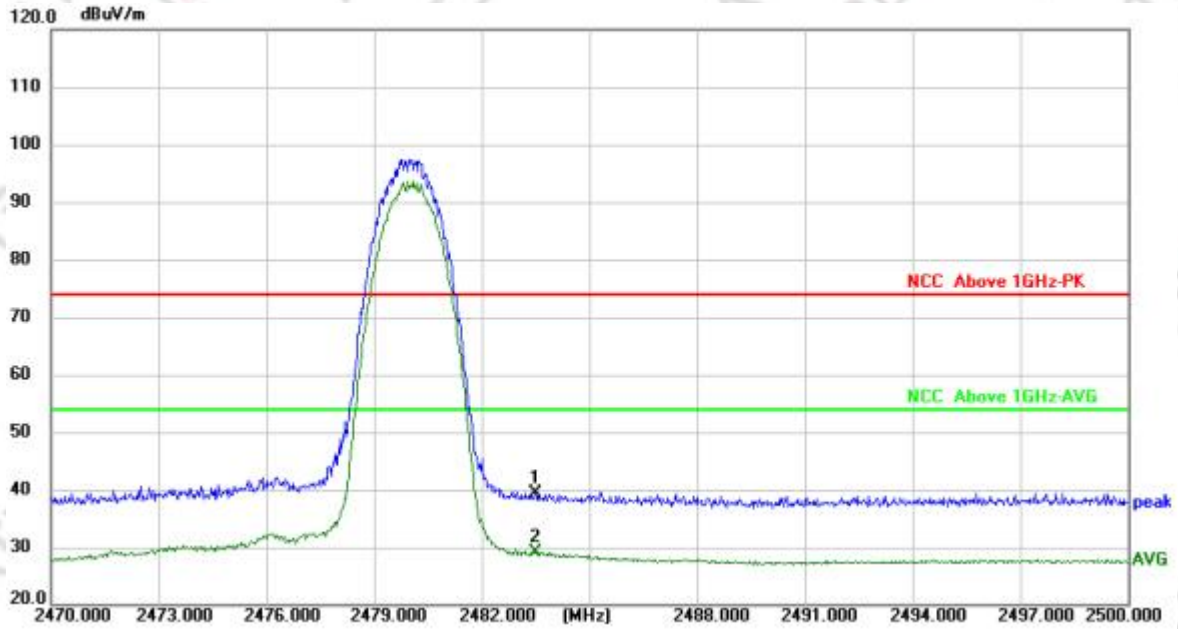

No.	Frequency (MHz)	Reading (dBuV)	Factor (dB/m)	Level (dBuV/m)	Limit (dBuV/m)	Margin (dB)	Detector
1	2483.500	53.94	-14.66	39.28	74.00	-34.72	peak
2 *	2483.500	43.76	-14.66	29.10	54.00	-24.90	AVG

Polarization	Horizontal	Mode	3DH5_2402
--------------	------------	------	-----------

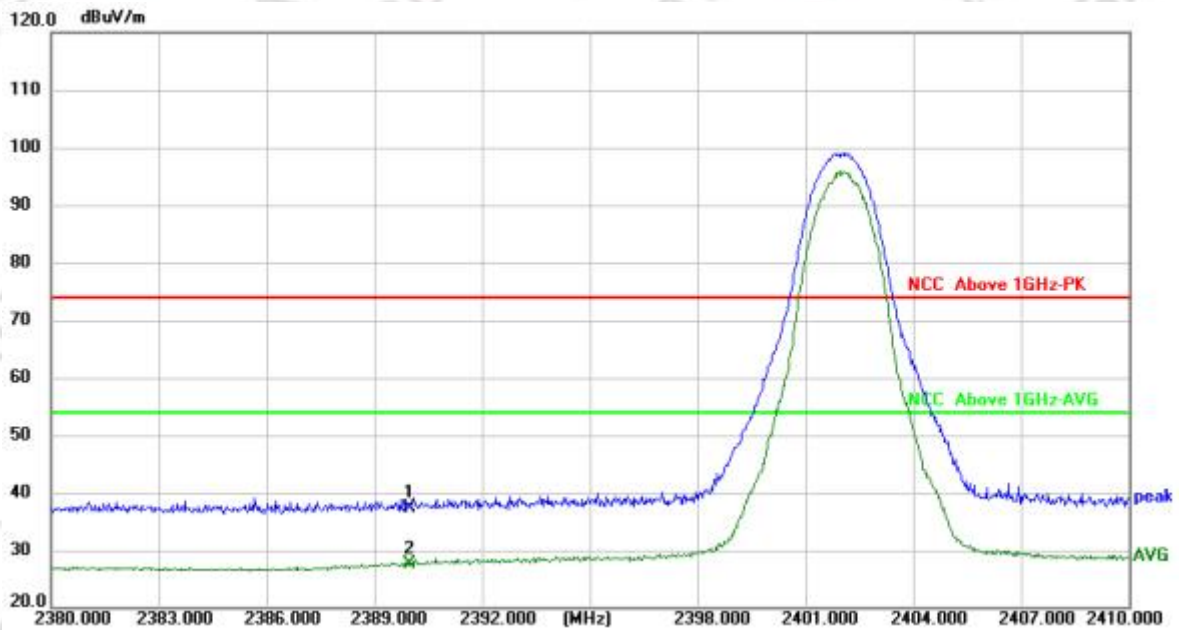

No.	Frequency (MHz)	Reading (dBuV)	Factor (dB/m)	Level (dBuV/m)	Limit (dBuV/m)	Margin (dB)	Detector
1	2390.000	52.58	-15.08	37.50	74.00	-36.50	peak
2 *	2390.000	42.67	-15.08	27.59	54.00	-26.41	AVG

Polarization	Vertical	Mode	3DH5_2402
--------------	----------	------	-----------

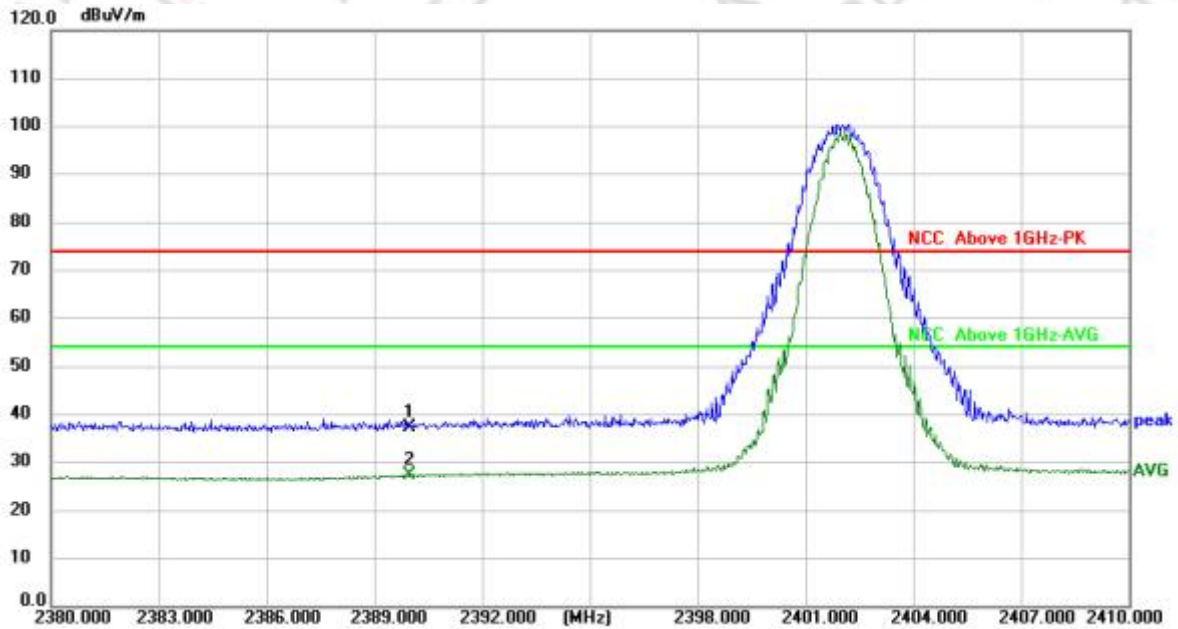

No.	Frequency (MHz)	Reading (dBuV)	Factor (dB/m)	Level (dBuV/m)	Limit (dBuV/m)	Margin (dB)	Detector
1	2390.000	52.52	-15.08	37.44	74.00	-36.56	peak
2 *	2390.000	42.51	-15.08	27.43	54.00	-26.57	AVG

Polarization	Horizontal	Mode	3DH5_2480
--------------	------------	------	-----------

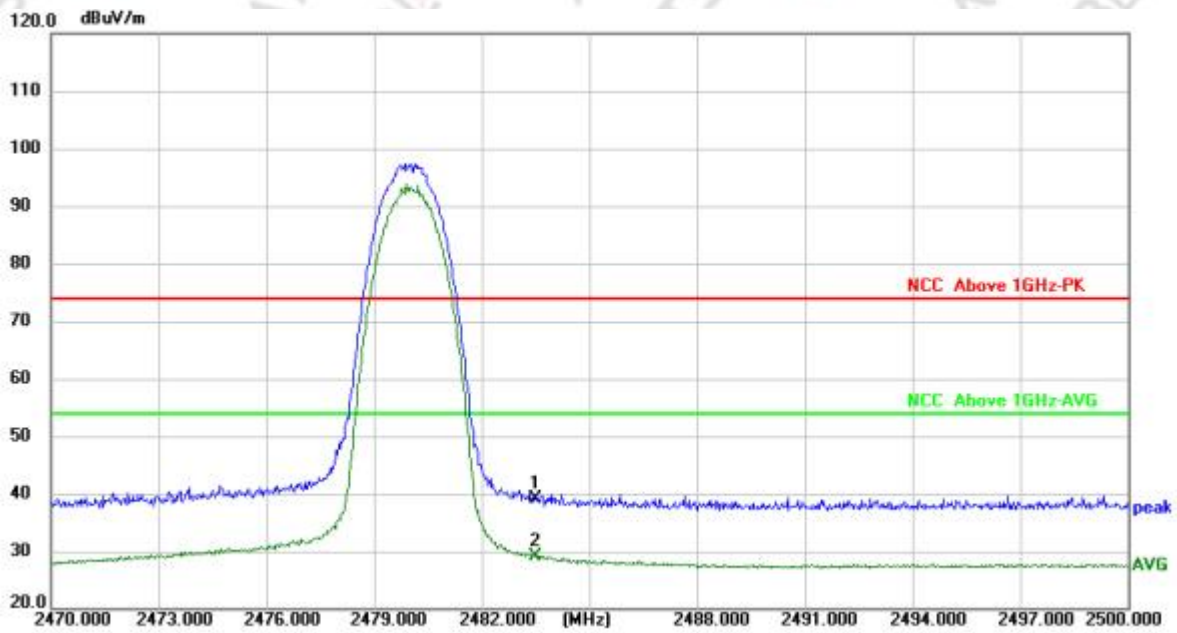

No.	Frequency (MHz)	Reading (dBuV)	Factor (dB/m)	Level (dBuV/m)	Limit (dBuV/m)	Margin (dB)	Detector
1	2483.500	53.68	-14.66	39.02	74.00	-34.98	peak
2 *	2483.500	43.80	-14.66	29.14	54.00	-24.86	AVG

Polarization	Vertical	Mode	3DH5_2480
--------------	----------	------	-----------

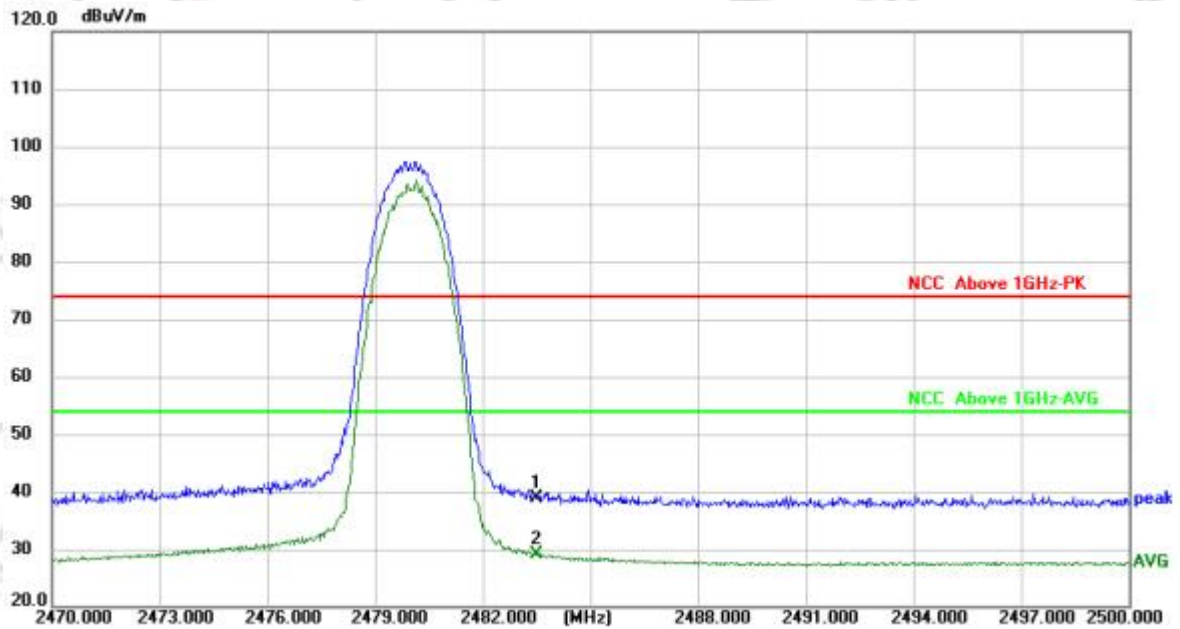

No.	Frequency (MHz)	Reading (dBuV)	Factor (dB/m)	Level (dBuV/m)	Limit (dBuV/m)	Margin (dB)	Detector
1	2483.500	53.44	-14.66	38.78	74.00	-35.22	peak
2 *	2483.500	43.68	-14.66	29.02	54.00	-24.98	AVG

Polarization	Horizontal	Mode	DH5_Hopping
--------------	------------	------	-------------

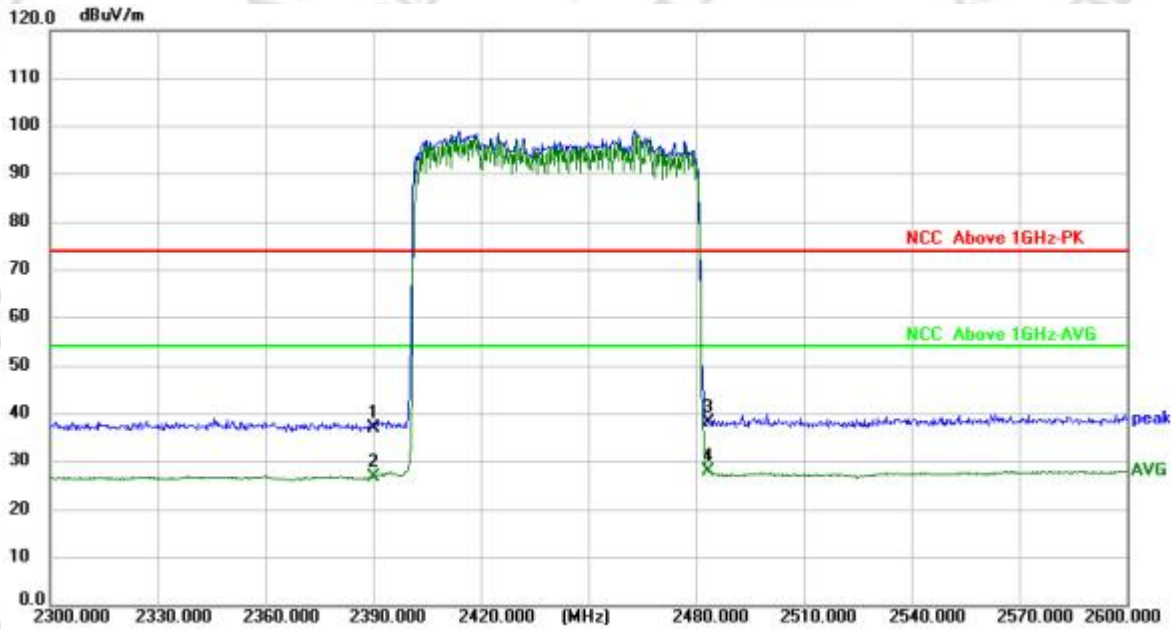

No.	Frequency (MHz)	Reading (dBuV)	Factor (dB/m)	Level (dBuV/m)	Limit (dBuV/m)	Margin (dB)	Detector
1	2390.000	52.15	-15.08	37.07	74.00	-36.93	peak
2	2390.000	41.83	-15.08	26.75	54.00	-27.25	AVG
3	2483.500	53.04	-14.66	38.38	74.00	-35.62	peak
4 *	2483.500	42.77	-14.66	28.11	54.00	-25.89	AVG

Polarization	Vertical	Mode	DH5_Hopping
--------------	----------	------	-------------



No.	Frequency (MHz)	Reading (dBuV)	Factor (dB/m)	Level (dBuV/m)	Limit (dBuV/m)	Margin (dB)	Detector
1	2390.000	52.38	-15.08	37.30	74.00	-36.70	peak
2	2390.000	42.36	-15.08	27.28	54.00	-26.72	AVG
3	2483.500	52.51	-14.66	37.85	74.00	-36.15	peak
4 *	2483.500	42.13	-14.66	27.47	54.00	-26.53	AVG

Polarization	Horizontal	Mode	2DH5_Hopping
--------------	------------	------	--------------

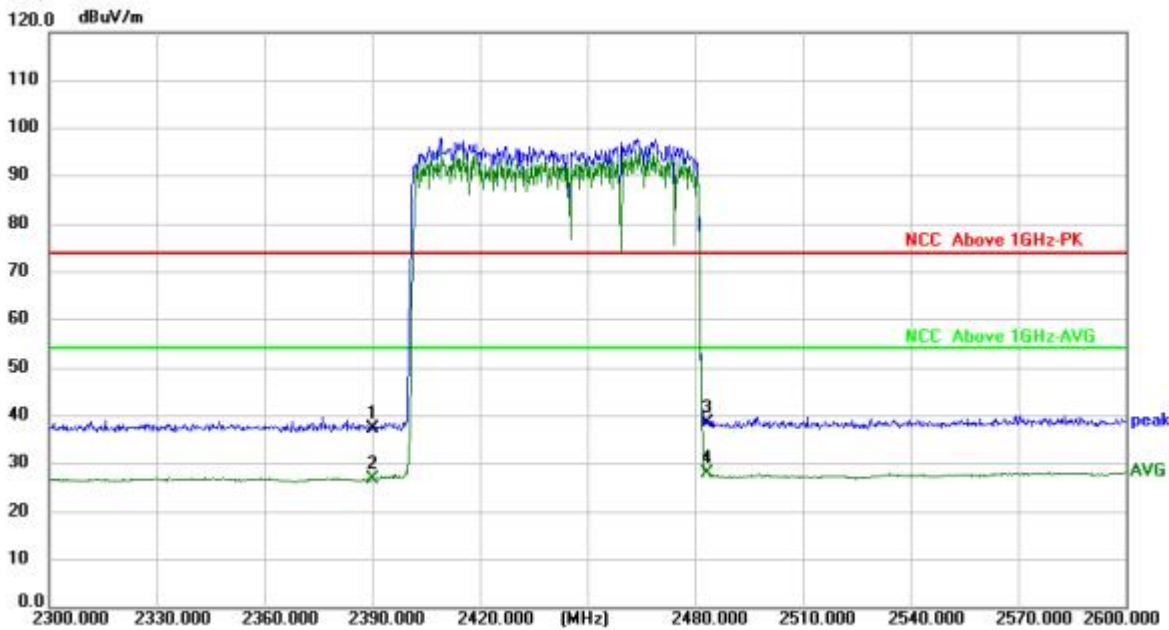

No.	Frequency (MHz)	Reading (dBuV)	Factor (dB/m)	Level (dBuV/m)	Limit (dBuV/m)	Margin (dB)	Detector
1	2390.000	52.32	-15.08	37.24	74.00	-36.76	peak
2	2390.000	41.85	-15.08	26.77	54.00	-27.23	AVG
3	2483.500	53.13	-14.66	38.47	74.00	-35.53	peak
4 *	2483.500	42.73	-14.66	28.07	54.00	-25.93	AVG

Polarization	Vertical	Mode	2DH5_Hopping
--------------	----------	------	--------------

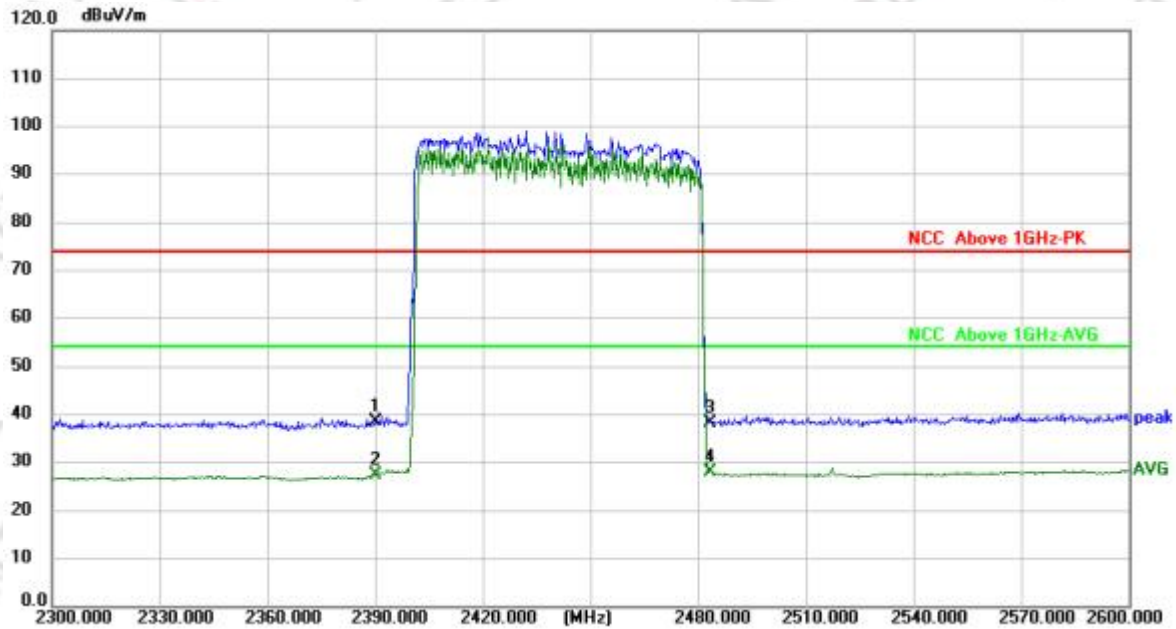

No.	Frequency (MHz)	Reading (dBuV)	Factor (dB/m)	Level (dBuV/m)	Limit (dBuV/m)	Margin (dB)	Detector
1	2390.000	53.54	-15.08	38.46	74.00	-35.54	peak
2	2390.000	42.56	-15.08	27.48	54.00	-26.52	AVG
3	2483.500	53.01	-14.66	38.35	74.00	-35.65	peak
4 *	2483.500	42.58	-14.66	27.92	54.00	-26.08	AVG

Polarization	Horizontal	Mode	3DH5_Hopping
--------------	------------	------	--------------

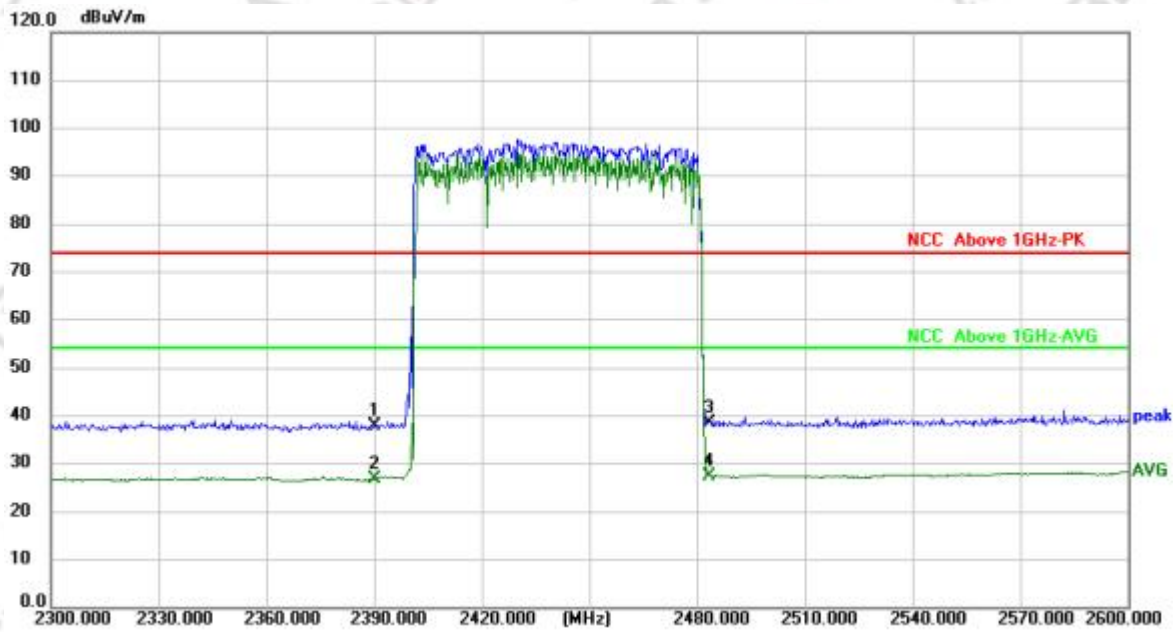

No.	Frequency (MHz)	Reading (dBuV)	Factor (dB/m)	Level (dBuV/m)	Limit (dBuV/m)	Margin (dB)	Detector
1	2390.000	52.99	-15.08	37.91	74.00	-36.09	peak
2	2390.000	41.99	-15.08	26.91	54.00	-27.09	AVG
3	2483.500	53.19	-14.66	38.53	74.00	-35.47	peak
4 *	2483.500	42.18	-14.66	27.52	54.00	-26.48	AVG

Polarization	Vertical	Mode	3DH5_Hopping
--------------	----------	------	--------------

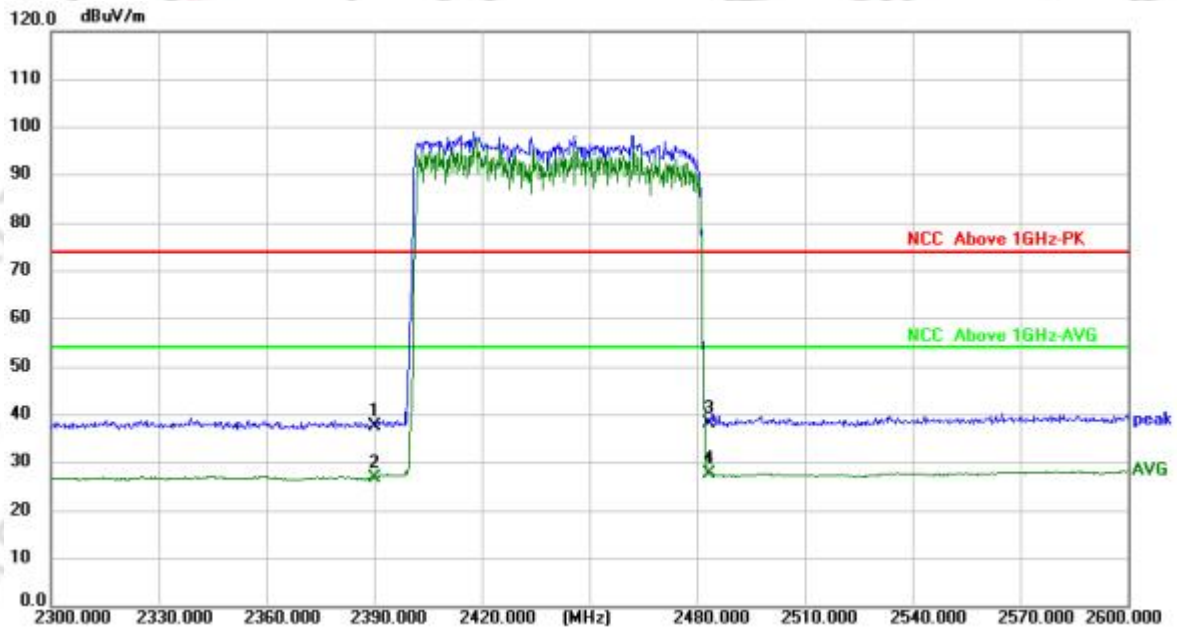

No.	Frequency (MHz)	Reading (dBuV)	Factor (dB/m)	Level (dBuV/m)	Limit (dBuV/m)	Margin (dB)	Detector
1	2390.000	52.82	-15.08	37.74	74.00	-36.26	peak
2	2390.000	41.99	-15.08	26.91	54.00	-27.09	AVG
3	2483.500	52.95	-14.66	38.29	74.00	-35.71	peak
4 *	2483.500	42.46	-14.66	27.80	54.00	-26.20	AVG

3.9. AC Power-Line Conducted Emission

3.9.1. Limit

47 CFR 15.207(a): For an intentional radiator that is designed to be connected to the public utility (AC) power line, the radio frequency voltage that is conducted back onto the AC power line on any frequency or frequencies, within the band 150 kHz to 30 MHz, shall not exceed the limits in the following table:

Frequency of emission (MHz)	Conducted limit (dB μ V)	
	Quasi-peak	Average
0.15-0.5	66 to 56*	56 to 46*
0.5-5	56	46
5-30	60	50

*Decreases with the logarithm of the frequency.

3.9.2. Test Procedure

1. The EUT was placed 0.4 meter from the conducting wall of the shielding room was kept at least 80 centimeters from any other grounded conducting surface.
2. Connect EUT to the power mains through a line impedance stabilization network (LISN).
3. All the support units are connecting to the other LISN.
4. The LISN provides 50 ohm coupling impedance for the measuring instrument.
5. The FCC states that a 50 ohm, 50 microhenry LISN should be used.
6. Both sides of AC line were checked for maximum conducted interference.
7. The frequency range from 150 kHz to 30 MHz was searched.
8. Set the test-receiver system to Peak Detect Function and specified bandwidth (IF Bandwidth = 9 kHz) with Maximum Hold Mode. Then measurement is also conducted by Average Detector and Quasi-Peak Detector Function respectively.

3.9.3. Test Setup

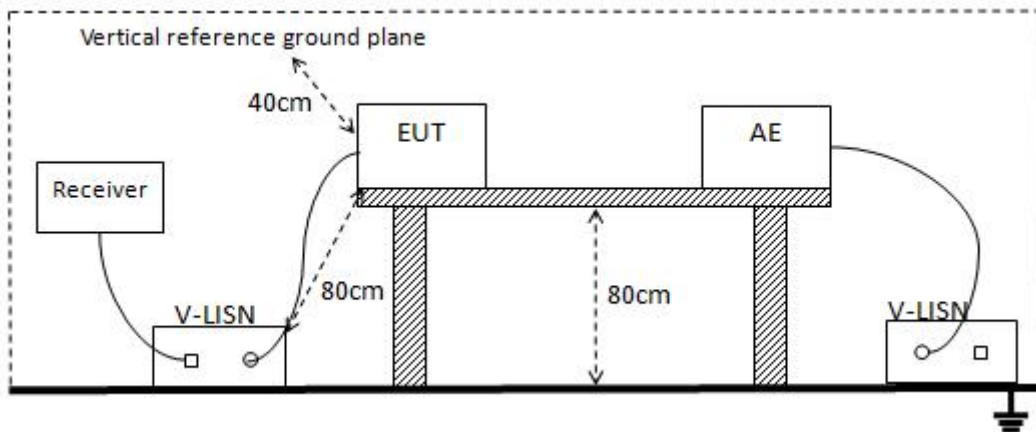

3.9.4. Test Result of AC Power-Line Conducted Emission

Note:

The product is battery powered and it is not working when charging, this item is not applicable.

3.10. Antenna Requirement

3.10.1. Standard Requirement

According to *47 CFR 15.203*, an intentional radiator shall be designed to ensure that no antenna other than that furnished by the responsible party shall be used with the device.

3.10.2. EUT Antenna

The antenna used for the EUT is ceramic antenna, which meets the antenna requirements.

4. TEST SETUP PHOTOGRAPHS

Please refer to the Appendix C.

5. EXTERNAL AND INTERNAL PHOTOS OF THE EUT

Please refer to the Appendix D.

XXXXXXXXEND OF THE REPORTXXXXXXXX