

Report on the Radio Testing  
For  
System Loco Ltd  
on  
LocoTrack Rechargeable  
Report no. TRA-054381-47-00AB  
17 June 2021

RF915 8.0



Report Number: TRA-054381-47-00AB  
Issue: B

REPORT ON THE RADIO TESTING OF A  
System Loco Ltd  
LocoTrack Rechargeable  
WITH RESPECT TO SPECIFICATION  
FCC 47CFR 15.247

TEST DATE: 17th May - 1st June 2021

Tested by: D Winstanley, M Else

Written by:

M.Else  
Radio Test Engineer

Approved by:

J Charters  
Laboratory Manager

Date: 17 June 2021

Disclaimers:

- [1] THIS DOCUMENT MAY BE REPRODUCED ONLY IN ITS ENTIRETY AND WITHOUT CHANGE  
[2] THE RESULTS CONTAINED IN THIS DOCUMENT RELATE ONLY TO THE ITEM(S) TESTED

## 1 Revision Record

<i>Issue Number</i>	<i>Issue Date</i>	<i>Revision History</i>
A	17 June 2021	Original
B	17 June 2021	Certification Amendments

## 2 Summary

TEST REPORT NUMBER: TRA-054381-47-00AB

WORKS ORDER NUMBER: TRA-054381-16

PURPOSE OF TEST: Certification

TEST SPECIFICATION: 47CFR15.247

EQUIPMENT UNDER TEST (EUT): LocoTrack Rechargeable

FCC IDENTIFIER: 2AYMO-LT-EP-43

EUT SERIAL NUMBER: Not stated

MANUFACTURER/AGENT: System Loco Ltd

ADDRESS: Parkfield,  
Greaves Park,  
Greaves Road,  
Lancaster,  
LA1 4TZ,  
United Kingdom

CLIENT CONTACT: Daniel Essafi  
☎ 07951587074  
✉ d.essafi@systemloco.com

TEST DATE: 17th May - 1st June 2021

TESTED BY: D Winstanley, M Else  
Element

## 2.1 Test Summary

<i>Test Method and Description</i>		<i>Requirement Clause 47CFR15</i>	<i>Applicable to this equipment</i>	<i>Result / Note</i>
Radiated spurious emissions (restricted bands of operation and cabinet radiation)		15.247 (d)	<input checked="" type="checkbox"/>	Pass
AC power line conducted emissions		15.207	<input checked="" type="checkbox"/>	Pass
Occupied bandwidth		15.247 (a) (2)	<input checked="" type="checkbox"/>	Pass
Conducted carrier power	Peak	15.247 (b) (3)	<input checked="" type="checkbox"/>	Pass
	Max.		<input type="checkbox"/>	
Out of band emissions		15.247 (d)	<input checked="" type="checkbox"/>	Pass
Power spectral density		15.247 (e)	<input checked="" type="checkbox"/>	Pass
Calculation of duty correction		-	<input type="checkbox"/>	-
Unintentional Radiated Emissions		15.109	<input checked="" type="checkbox"/>	Pass

### Specific Note:

During AC Powerline conducted emissions testing all transmitters were active

### General Notes:

The results contained in this report relate only to the items tested, in the condition at time of test, and were obtained in the period between the date of initial receipt of samples and the date of issue of the report.

The apparatus was set up and exercised using the configurations, modes of operation and arrangements defined in this report only. Any modifications made are identified in Section 8 of this report.

Particular operating modes, apparatus monitoring methods and performance criteria required by the standards tested to have been performed except where identified in Section 5.2 of this test report (Deviations from Test Standards).

### 3 Contents

1	Revision Record .....	3
2	Summary .....	4
2.1	Test Summary .....	5
3	Contents .....	6
4	Introduction .....	8
5	Test Specifications .....	9
5.1	Normative References .....	9
5.2	Deviations from Test Standards .....	9
6	Glossary of Terms .....	10
7	Equipment under Test .....	11
7.1	EUT Identification .....	11
7.2	System Equipment.....	11
7.3	EUT Mode of Operation.....	11
7.4	EUT Radio Parameters.....	12
7.4.1	General.....	12
7.4.2	Antennas .....	12
7.4.3	Product specific declarations .....	12
7.5	EUT Description.....	12
8	Modifications.....	13
9	EUT Test Setup .....	14
9.1	Block Diagram .....	14
9.2	General Set-up Photograph .....	15
9.3	Measurement software .....	15
10	General Technical Parameters .....	16
10.1	Normal Conditions .....	16
10.2	Varying Test Conditions.....	16
11	Radiated emissions .....	17
11.1	Definitions .....	17
11.2	Test Parameters .....	17
11.3	Test Limit .....	17
11.4	Test Method.....	18
11.5	Test Equipment.....	19
11.6	Test Results – HFR4 – Mains Charger .....	20
12	AC power-line conducted emissions.....	24
12.1	Definition.....	24
12.2	Test Parameters .....	24
12.3	Test Limit .....	24
12.4	Test Method.....	25
12.5	Test Set-up Photograph.....	26
12.6	Test Equipment.....	27
12.7	Test Results – Wireless Charger .....	28
12.8	Test Results – Mains Charger .....	30
13	Occupied Bandwidth.....	32
13.1	Definition.....	32
13.2	Test Parameters .....	32
13.3	Test Limit .....	32
13.4	Test Method.....	33
13.5	Test Equipment.....	33
13.6	Test Results.....	34
14	Maximum peak conducted output power .....	35
14.1	Definition.....	35
14.2	Test Parameters .....	35
14.3	Test Limit .....	35
14.4	Test Method.....	36
14.5	Test Equipment.....	36
14.6	Test Results.....	37
15	Out-of-band and conducted spurious emissions.....	38
15.1	Definition.....	38
15.2	Test Parameters .....	38
15.3	Test Limit .....	38
15.4	Test Method.....	39
15.5	Test Equipment.....	39
15.6	Test Results.....	40
16	Power spectral density.....	43
16.1	Definition.....	43
16.2	Test Parameters .....	43

16.3	Test Limit .....	43
16.4	Test Method.....	44
16.5	Test Equipment.....	44
16.6	Test Results.....	45
17	Radiated emissions – unintentional radiation / receiver emissions.....	46
17.1	Definitions .....	46
17.2	Test Parameters .....	46
17.3	Test Limit .....	46
17.4	Test Method.....	47
17.5	Test Equipment.....	48
17.6	Test Results – HFR4 – Mains Charger .....	49
17.7	Test Results – HGR4 – Wireless Charger .....	52
18	Measurement Uncertainty.....	55
19	MPE Calculation .....	57

## 4 Introduction

This report TRA-054381-47-00A presents the results of the Radio testing on a System Loco Ltd, LocoTrack Rechargeable to specification 47CFR15 Radio Frequency Devices.

The testing was carried out for System Loco Ltd by Element, at the address detailed below.

<input type="checkbox"/>	Element Hull Unit E South Orbital Trading Park Hedon Road Hull HU9 1NJ UK	<input checked="" type="checkbox"/>	Element Skelmersdale Unit 1 Pendle Place Skelmersdale West Lancashire WN8 9PN UK
--------------------------	---	-------------------------------------	--

This report details the configuration of the equipment, the test methods used and any relevant modifications where appropriate.

All test and measurement equipment under the control of the laboratory and requiring calibration is subject to an established programme and procedures to control and maintain measurement standards. The quality management system meets the principles of ISO 9001, and has quality control procedures for monitoring the validity of tests undertaken. Records and sufficient detail are retained to establish an audit trail of calibration records relating to its test results for a defined period. Under control of the established calibration programme, key quantities or values of the test & measurement instrumentation are within specification and comply with the relevant traceable internationally recognised and appropriate standard specifications, which are UKAS calibrated as such where these properties have a significant effect on results. Participation in inter-laboratory comparisons and proficiency testing ensures satisfactory correlation of results conform to Elements own procedures, as well as statistical techniques for analysis of test data providing the appropriate confidence in measurements.

Throughout this report EUT denotes equipment under test.

FCC Site Listing:

The test laboratory is accredited for the above sites under the US-UK MRA,

Designation number(s):

Element Hull UK2007

Element Skelmersdale UK2020

The test site requirements of ANSI C63.4-2014 are met up to 1GHz.

The test site SVSWR requirements of CISPR 16-1-4:2010 are met over the frequency range 1 GHz to 18 GHz.



## **5 Test Specifications**

### **5.1 Normative References**

- FCC 47 CFR Ch. I – Part 15 – Radio Frequency Devices.
- ANSI C63.10-2013 – American National Standard of Procedures for Compliance Testing of Unlicensed Wireless Devices.
- ANSI C63.4-2014 – American National Standard for Methods of Measurement of Radio-Noise Emissions from Low-Voltage Electrical and Electronic Equipment in the Range of 9 kHz to 40 GHz.

### **5.2 Deviations from Test Standards**

There were no deviations from the test standard.

## 6 Glossary of Terms

<b>§</b>	denotes a section reference from the standard, not this document
<b>AC</b>	Alternating Current
<b>ANSI</b>	American National Standards Institute
<b>BW</b>	bandwidth
<b>C</b>	Celsius
<b>CFR</b>	Code of Federal Regulations
<b>CW</b>	Continuous Wave
<b>dB</b>	decibel
<b>dBm</b>	dB relative to 1 milliwatt
<b>DC</b>	Direct Current
<b>DSSS</b>	Direct Sequence Spread Spectrum
<b>EIRP</b>	Equivalent Isotropically Radiated Power
<b>ERP</b>	Effective Radiated Power
<b>EUT</b>	Equipment under Test
<b>FCC</b>	Federal Communications Commission
<b>FHSS</b>	Frequency Hopping Spread Spectrum
<b>Hz</b>	hertz
<b>IC</b>	Industry Canada
<b>ITU</b>	International Telecommunication Union
<b>LBT</b>	Listen before Talk
<b>m</b>	metre
<b>max</b>	maximum
<b>MIMO</b>	Multiple Input and Multiple Output
<b>min</b>	minimum
<b>MRA</b>	Mutual Recognition Agreement
<b>N/A</b>	Not Applicable
<b>PCB</b>	Printed Circuit Board
<b>PDF</b>	Portable Document Format
<b>Pt-mpt</b>	Point-to-multipoint
<b>Pt-pt</b>	Point-to-point
<b>RF</b>	Radio Frequency
<b>RH</b>	Relative Humidity
<b>RMS</b>	Root Mean Square
<b>Rx</b>	receiver
<b>s</b>	second
<b>SVSWR</b>	Site Voltage Standing Wave Ratio
<b>Tx</b>	transmitter
<b>UKAS</b>	United Kingdom Accreditation Service
<b>V</b>	volt
<b>W</b>	watt
<b>Ω</b>	ohm

## 7 Equipment under Test

### 7.1 EUT Identification

- Name: LocoTrack Rechargeable
- Serial Number: Not stated
- Model Number: HFR4 with charging cable and HGR4 without charging cable (Wirelessly Charged)
- Software Revision: Test\_Firmware\_01
- Build Level / Revision Number: 2.0

### 7.2 System Equipment

Equipment listed below forms part of the overall test setup and is required for equipment functionality and/or monitoring during testing. The compliance levels achieved in this report relate only to the EUT and not items given in the following list.

Wireless Charger,

Manufacturer: CHOETECH  
Model no: CHOETECH T511  
FCC ID: 2ARDY-T511

Mains Charger,

Manufacturer: Strontronics  
Model Number: T5875DV

### 7.3 EUT Mode of Operation

The BLE radio has been loaded up with some radio test firmware supplied by the manufacturer. This enables the radio to be configured as required for testing. The configuration is done via a serial cable set to 115200, 8 bits, 1 stop bit, no parity, no flow control. The serial port is accessible on the EUT.

The EUT is setup for top, middle or bottom frequencies with a power setting of 0 dBm and 1 Mbps data rate for transmit mode.

## 7.4 EUT Radio Parameters

### 7.4.1 General

<b>Frequency of operation:</b>	2402 MHz – 2480 MHz
<b>Modulation type(s):</b>	GFSK
<b>Data Rate:</b>	1 Mbps only employed
<b>Occupied channel bandwidth(s):</b>	2 MHz
<b>Channel spacing:</b>	2 MHz
<b>ITU emission designator(s):</b>	F1D
<b>Declared output power(s):</b>	0 dBm
<b>Nominal Supply Voltage:</b>	3.7 Vdc
<b>Location of notice for license exempt use:</b>	Label / user manual / both.
<b>Duty cycle:</b>	100% for test

### 7.4.2 Antennas

<b>Type:</b>	PCB Trace
<b>Frequency range:</b>	2400 MHz – 2485 MHz
<b>Gain:</b>	3.27 dBi
<b>Connector type:</b>	Integral

### 7.4.3 Product specific declarations

<b>Multiple antenna configuration(s), e.g. MIMO:</b>	Single
<b>Fixed pt-pt operations (yes/no):</b>	No
<b>Installation manual advice on pt-pt operational restrictions (yes/no):</b>	No
<b>Fixed pt-mpt operations (yes/no):</b>	No
<b>Simultaneous tx (yes/no):</b>	No

## 7.5 EUT Description

The EUT is GPS tracking device, one variant - HFR4 - has a mains power supply, the other - HGR4 - is wirelessly charged.

## **8 Modifications**

No modifications were performed during this assessment.

## 9 EUT Test Setup

### 9.1 Block Diagram

The following diagram shows basic EUT interconnections :

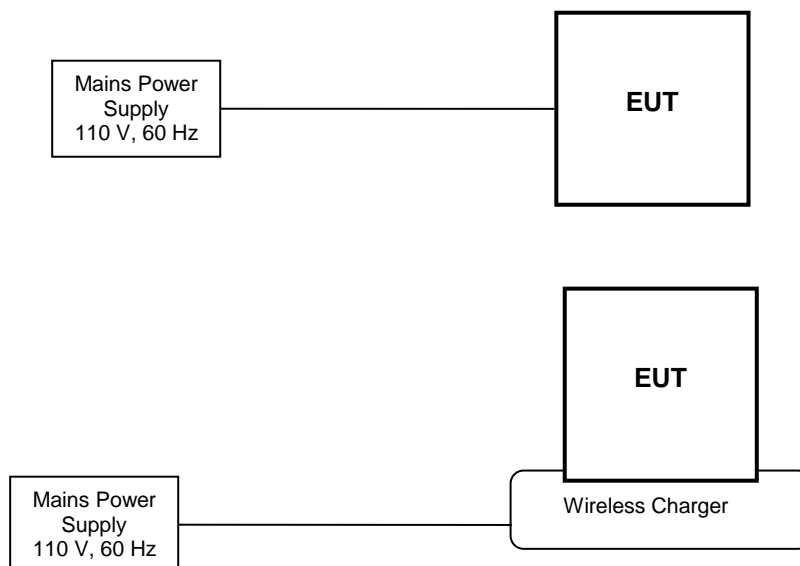

## 9.2 General Set-up Photograph

The following photograph shows basic EUT set-up:

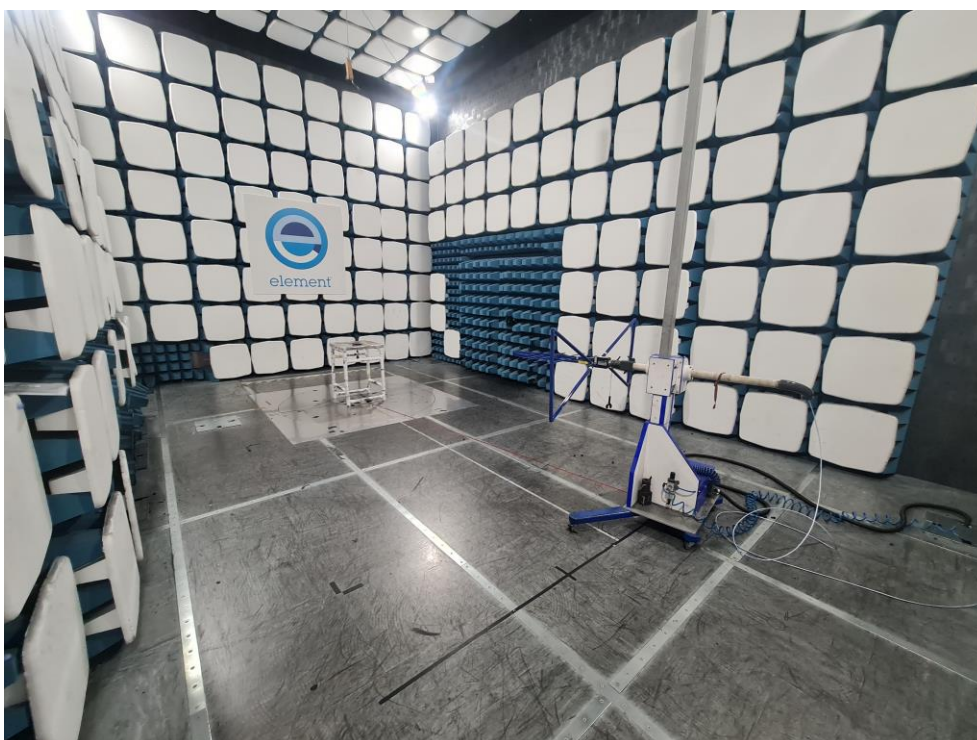

## 9.3 Measurement software

Where applicable, the following software was used to perform measurements contained within this report.

Element Emissions R5  
Rohde & Schwarz EMC32 V8.54

## 10 General Technical Parameters

### 10.1 Normal Conditions

The EUT was tested under the normal environmental conditions of the test laboratory, except where otherwise stated. The normal power source applied was 3.7 Vdc from the internal battery while charging from 110 Vac, 60 Hz, from the mains or via the wireless charger where required.

### 10.2 Varying Test Conditions

There are no specific frequency stability requirements for the type of device. The results contained in this report demonstrate that the occupied bandwidth is contained within the authorised band.

Variation of supply voltage is required to ensure stability of the declared output power. During carrier power testing the following variations were made:

	<b>Category</b>	<b>Nominal</b>	<b>Variation</b>
<input type="checkbox"/>	Mains	110 Vac +/-2 %	85 % and 115 %
<input checked="" type="checkbox"/>	Battery	Fully Charged battery	N/A



## 11 Radiated emissions

### 11.1 Definitions

#### *Spurious emissions*

Emissions on a frequency or frequencies, which are outside the necessary bandwidth and the level of which may be reduced without affecting the corresponding transmission of information. Spurious emissions include harmonic emissions, parasitic emissions, intermodulation products and frequency conversion products, but exclude out-of-band emissions.

#### *Restricted bands*

A frequency band in which intentional radiators are permitted to radiate only spurious emissions but not fundamental signals.

### 11.2 Test Parameters

Test Location:	Element Skelmersdale
Test Chamber:	Chamber 01
Test Standard and Clause:	ANSI C63.10-2013, Clause 6.5 and 6.6
EUT Frequencies Measured:	2402 MHz, 2440 MHz, 2480 MHz
Deviations from Standard:	None
Measurement BW:	30 MHz to 1 GHz: 120 kHz; Above 1 GHz: 1 MHz
Measurement Detector:	Up to 1 GHz: quasi-peak; Above 1 GHz: RMS average and Peak

#### **Environmental Conditions (Normal Environment)**

Temperature: 19.2 °C	+15 °C to +35 °C (as declared)
Humidity: 39 % RH	20 % RH to 75 % RH (as declared)
Supply: 110 V ac, 60 Hz	As declared

### 11.3 Test Limit

Unwanted emissions that fall within the restricted frequency bands shall comply with the limits specified:

#### **General Field Strength Limits for License-Exempt Transmitters at Frequencies above 30 MHz**

<b>Frequency (MHz)</b>	<b>Field Strength (<math>\mu\text{V}/\text{m}</math> at 3 m)</b>	<b>Field Strength (dB<math>\mu\text{V}/\text{m}</math> at 3 m)</b>
30 to 88	100	40.0
88 to 216	150	43.5
216 to 960	200	46.0
Above 960	500	54.0

On frequencies below or equal to 1000 MHz, the limits shown are based on measuring equipment employing a CISPR quasi-peak detector function. On frequencies above 1000 MHz, the radiated emission limits are based on the use of measurement instrumentation employing an average detector function. The limit on peak radio frequency emissions is 20 dB above the maximum permitted average emission limit.

## 11.4 Test Method

With the EUT setup as per section 9 of this report and connected as per Figure i, the emissions from the EUT were measured on a spectrum analyzer / EMI receiver.

Radiated electromagnetic emissions from the EUT are checked first by preview scans. Preview scans for all spectrum and modulation characteristics are checked, using a peak detector and where applicable worst-case determined for function, operation, orientation, etc. for both vertical and horizontal polarisations. Pre-scan plots are shown with a peak detector and 100 kHz RBW.

If the EUT connects to auxiliary equipment and is table or floor standing, the configurations prescribed in ANSI C63.10 are followed. Alternatively, a layout closest to normal use (as declared by the provider) is employed, (see EUT setup photographs for more detail).

Emissions between 30 MHz and 1 GHz are measured using calibrated broadband antennas. Emissions above 1 GHz are characterized using standard gain horn antennas. Pre-amplifiers and filters are used where required. Care is taken to ensure that test receiver resolution bandwidth, video bandwidth and detector type(s) meet the regulatory requirements.

For both horizontal and vertical polarizations, the EUT is then rotated through 360 degrees in azimuth until the highest emission is detected. At the previously determined azimuth the test antenna is raised and lowered from 1 to 4 m in height until a maximum emission level is detected, this maximum value is recorded.

Power values measured on the test receiver / analyzer are converted to field strength, FS, in dB $\mu$ V/m at the regulatory distance, using:

$$FS = PR + CL + AF - PA + DC - CF$$

$$\text{Factor} = CL + AF - PA$$

Where,

PR is the power recorded on the receiver / spectrum analyzer in dB $\mu$ V;

CL is the cable loss in dB;

AF is the test antenna factor in dB/m;

PA is the pre-amplifier gain in dB (where used);

DC is the duty correction factor in dB (where used, e.g. harmonics of pulsed fundamental);

CF is the distance factor in dB (where measurement distance different to limit distance);

This field strength value is then compared with the regulatory limit.

**Figure i Test Setup**

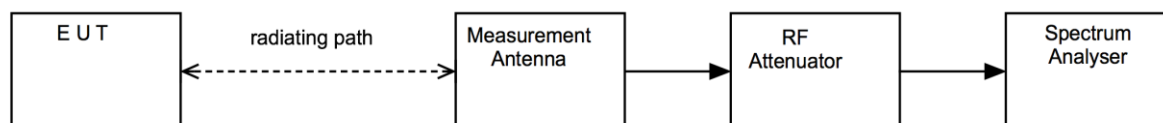

**11.5 Test Equipment**

<b>Equipment Description</b>	<b>Manufacturer</b>	<b>Equipment Type</b>	<b>Element No</b>	<b>Due For Calibration</b>
Radiated Test Software	Element	Emissions R5	REF9000	Cal not required
Signal Generator	R&S	SMB100A	U677	2022-01-26
Chamber 1	Rainford EMC	ATS	U387	2021-09-09
Pre Amp	Agilent	8449B	L572	2021-10-19
PreAmp	Watkins Johnson	6201-69	U372	2022-03-01
Bilog	Chase	CBL611/A	U573	2023-01-28
1-18GHz Horn	EMCO	3115	U223	2021-11-05
2.4G Band Stop Filter	BSC	SN 4478	U543	2022-01-30
1-18GHz Horn	EMCO	3115	L139	2021-07-16
Spectrum Analyser	R&S	FSW 26.5	*101805	2021-07-23
Spectrum Analyser	R&S	FSU26	U405	2021-07-17

\*Denotes serial number of hired test equipment

### 11.6 Test Results – HFR4 – Mains Charger

Frequency: 2402 MHz; Power Setting: 0 dBm; Modulation: GFSK; Data Rate: 1Mb/s								
Detector	Freq. (MHz)	Meas'd Emission (dBµV)	Factor (dB)	Duty Cycle Corr'n (dB)	Distance Extrap'n Factor (dB)	Field Strength (dBµV/m)	Limit (dBµV/m)	Margin (dB)
QP	148.7046	45.6	-10.8	0	0	34.8	43.5	-8.7
AV	2337.942	48.7	-4.1	0	0	44.6	54.00	-9.4

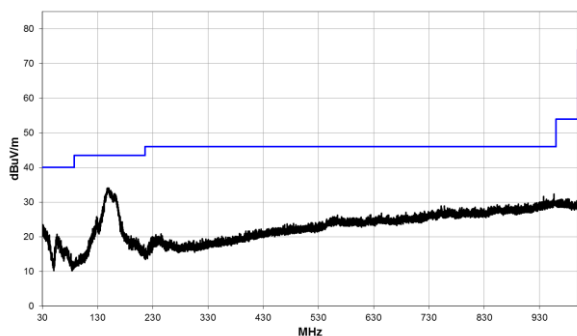

30 MHz to 1 GHz

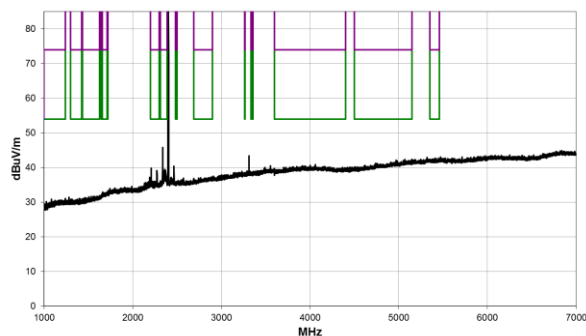

1 GHz to 7 GHz

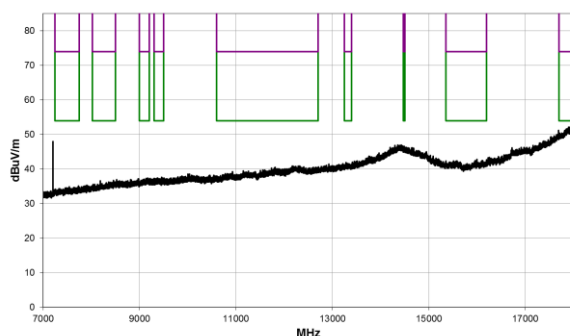

7 GHz to 18 GHz

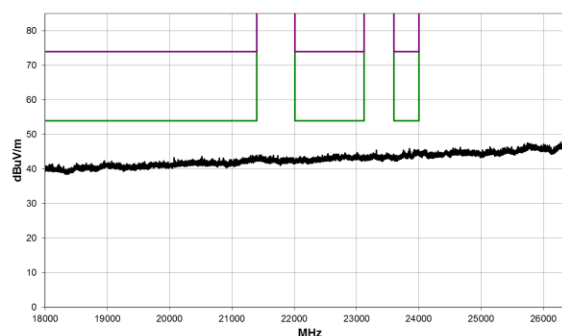

18 GHz to 26.5 GHz

Frequency: 2440 MHz; Power Setting: 0 dBm; Modulation: GFSK; Data Rate: 1Mb/s								
Detector	Freq. (MHz)	Meas'd Emission (dBµV)	Factor (dB)	Duty Cycle Corr'n (dB)	Distance Extrap'n Factor (dB)	Field Strength (dBµV/m)	Limit (dBµV/m)	Margin (dB)
QP	148.7046	45.6	-10.8	0	0	34.8	43.5	-8.7
AV	7319.850	51.7	7.6	0	-9.5	49.8	54	-4.2
AV	7319.859	46.7	7.6	0	-9.5	44.8	54	-9.2

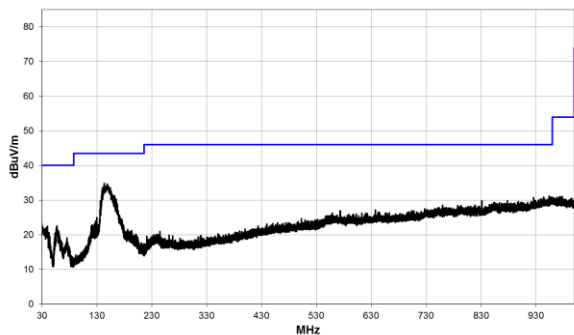

30 MHz to 1 GHz

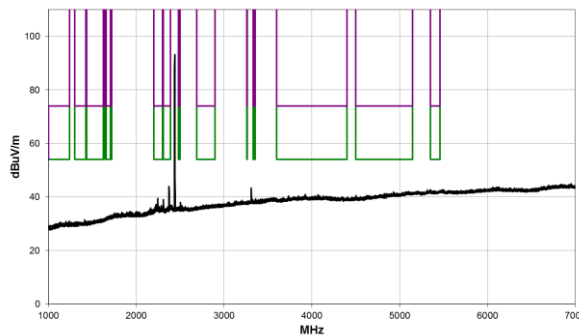

1 GHz to 7 GHz

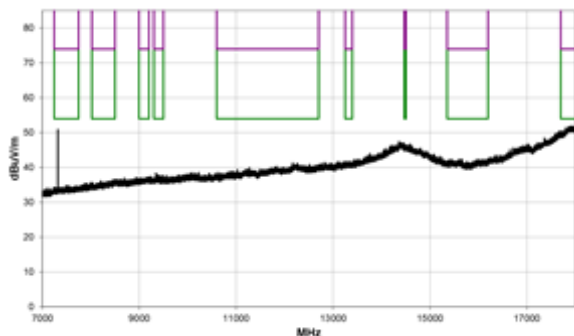

7 GHz to 18 GHz

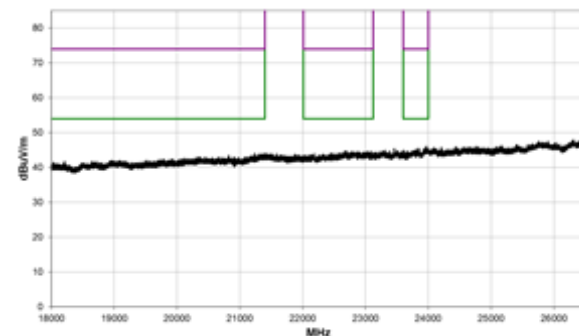

18 GHz to 26.5 GHz

Frequency: 2480 MHz; Power Setting: 0 dBm; Modulation: GFSK; Data Rate: 1Mb/s								
Detector	Freq. (MHz)	Meas'd Emission (dBμV)	Factor (dB)	Duty Cycle Corr'n (dB)	Distance Extrap'n Factor (dB)	Field Strength (dBμV/m)	Limit (dBμV/m)	Margin (dB)
QP	148.7046	45.6	-10.8	0	0	34.8	43.5	-8.7
AV	7439.842	53.3	7.7	0	-9.5	51.5	54	-2.5
AV	7439.85	48	7.7	0	-9.5	46.2	54	-7.8

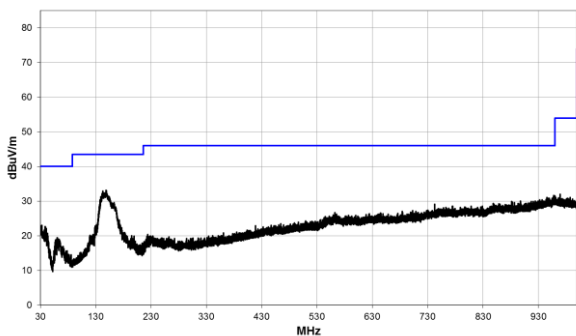

30 MHz to 1 GHz

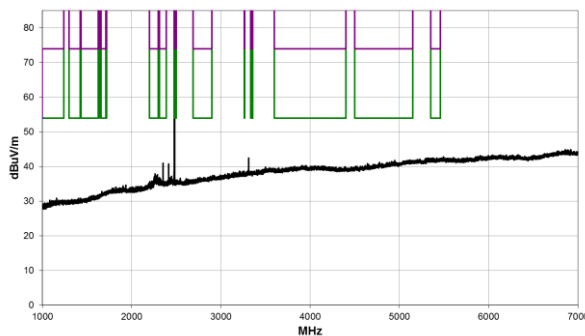

1 GHz to 7 GHz

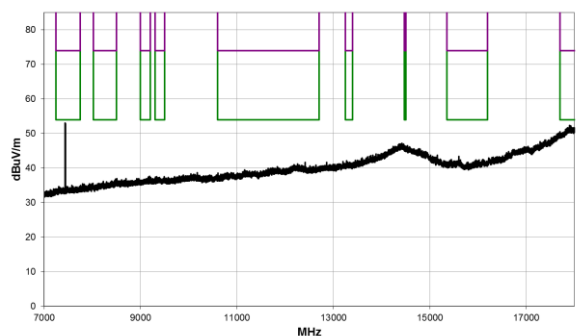

7 GHz to 18 GHz

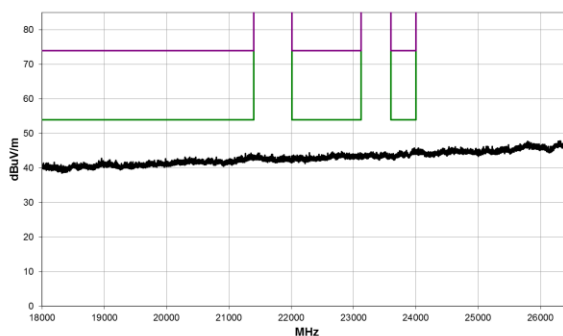

18 GHz to 26.5 GHz

### Upper radiated band edge, Peak.

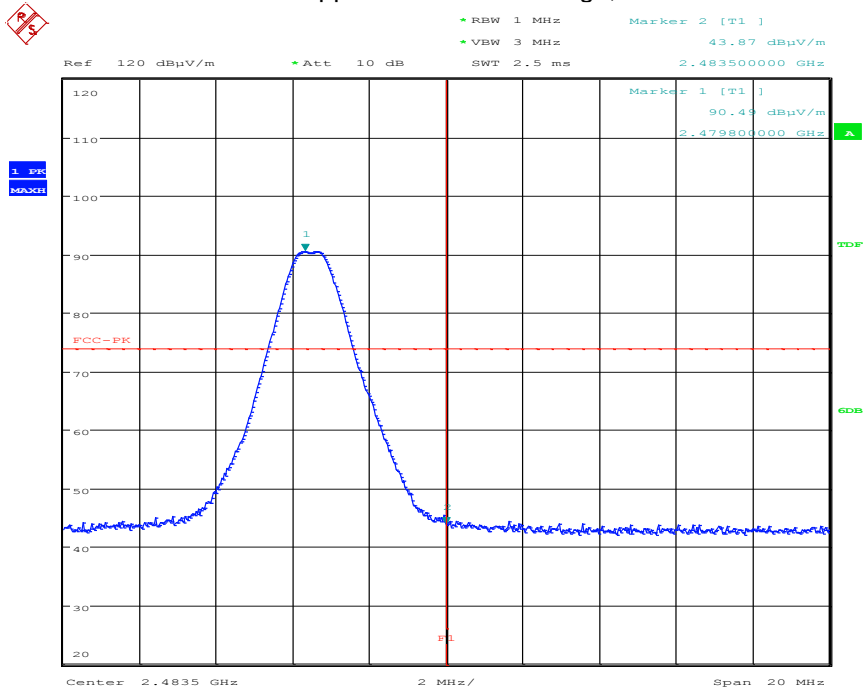

Date: 17.MAY.2021 17:13:27

### Upper radiated band edge, Average.

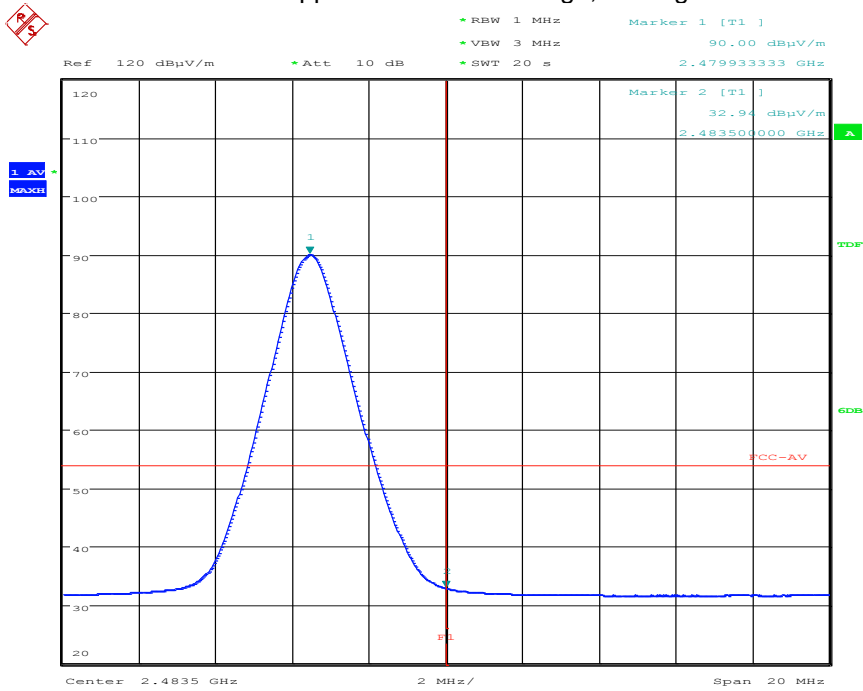

Date: 17.MAY.2021 17:18:07

## 12 AC power-line conducted emissions

### 12.1 Definition

Line-to-ground radio-noise voltage that is conducted from all of the EUT current-carrying power input terminals that are directly (or indirectly via separate transformers or power supplies) connected to a public power network.

### 12.2 Test Parameters

Test Location:	Element Skelmersdale
Test Chamber:	LF Lab
Test Standard and Clause:	ANSI C63.10-2013, Clause 6.2
EUT Active transmitters:	WiFi- TX, BLE TX, Cellular TX
Deviations From Standard:	None
Measurement BW:	9 kHz
Measurement Detectors:	Quasi-Peak and Average, RMS

### Environmental Conditions (Normal Environment)

Temperature: 20 °C	+15 °C to +35 °C (as declared)
Humidity: 44 % RH	20 % RH to 75 % RH (as declared)

### 12.3 Test Limit

A radio apparatus that is designed to be connected to the public utility (AC) power line shall ensure that the radio frequency voltage, which is conducted back onto the AC power line on any frequency or frequencies within the band 150 kHz to 30 MHz, shall not exceed the limits in Table 3.

**Table 3 – AC Power Line Conducted Emission Limits**

Frequency (MHz)	Conducted limit (dB $\mu$ V)	
	Quasi-Peak	Average**
0.15 to 0.5	66 to 56*	56 to 46*
0.5 to 5	56	46
5 to 30	60	50

\*The level decreases linearly with the logarithm of the frequency.

\*\*A linear average detector is required.



## 12.4 Test Method

With the EUT setup in a screened room, as per section 9 of this report and connected as per Figure ii, the power line emissions were measured on a spectrum analyzer / EMI receiver.

AC power line conducted emissions from the EUT are checked first by preview scans with peak and average detectors covering both live and neutral lines. A spectrum analyzer is used to determine if any periodic emissions are present.

Formal measurements using the correct detector(s) and bandwidth are made on frequencies identified from the preview scans. Final measurements were performed with EUT set at its maximum duty in transmit and receive modes.

**Figure ii Test Setup**

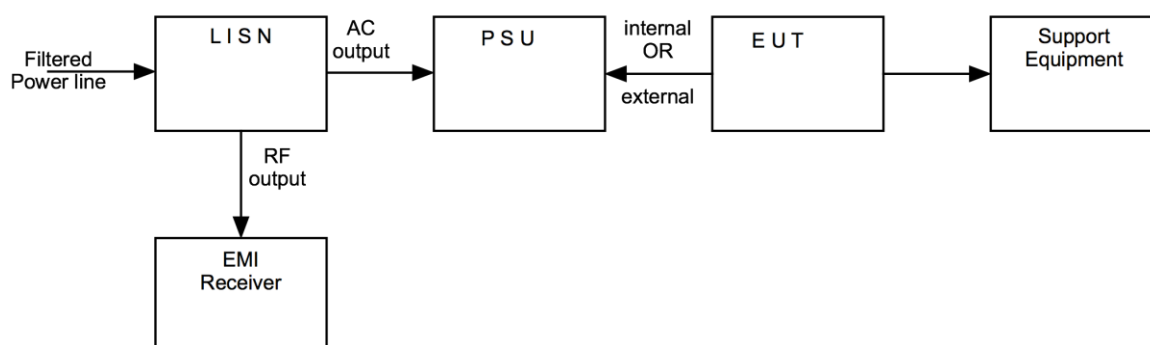

### 12.5 Test Set-up Photograph

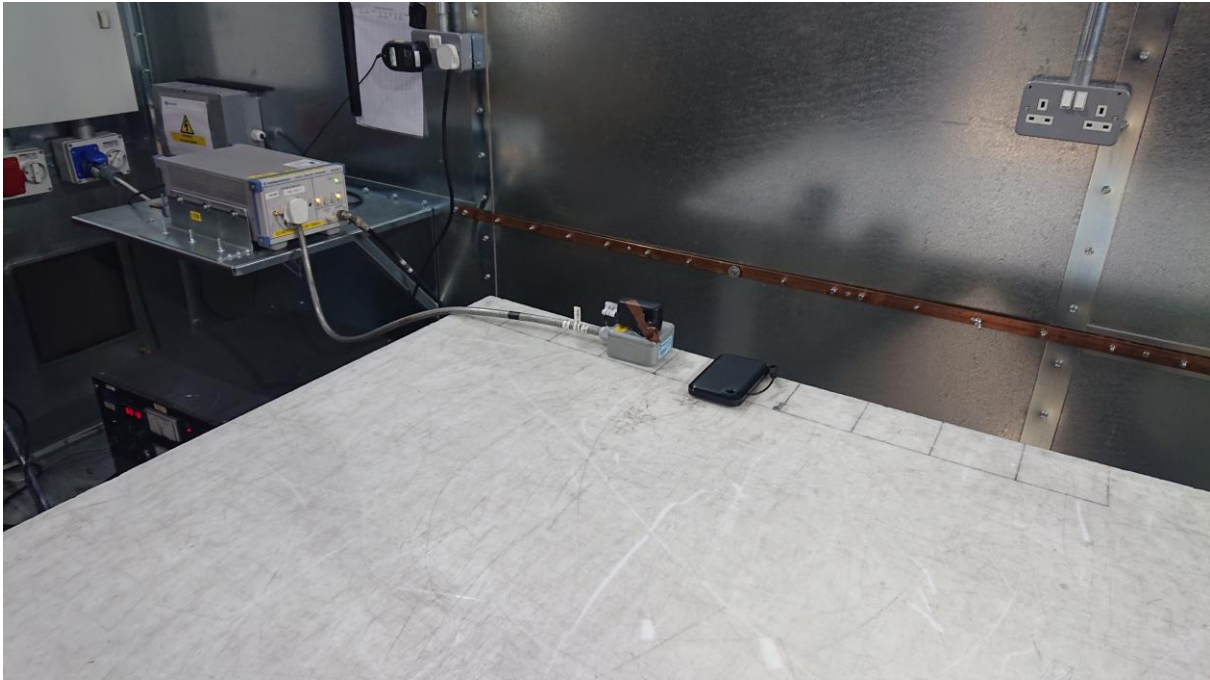

Test Setup - Wireless Charger

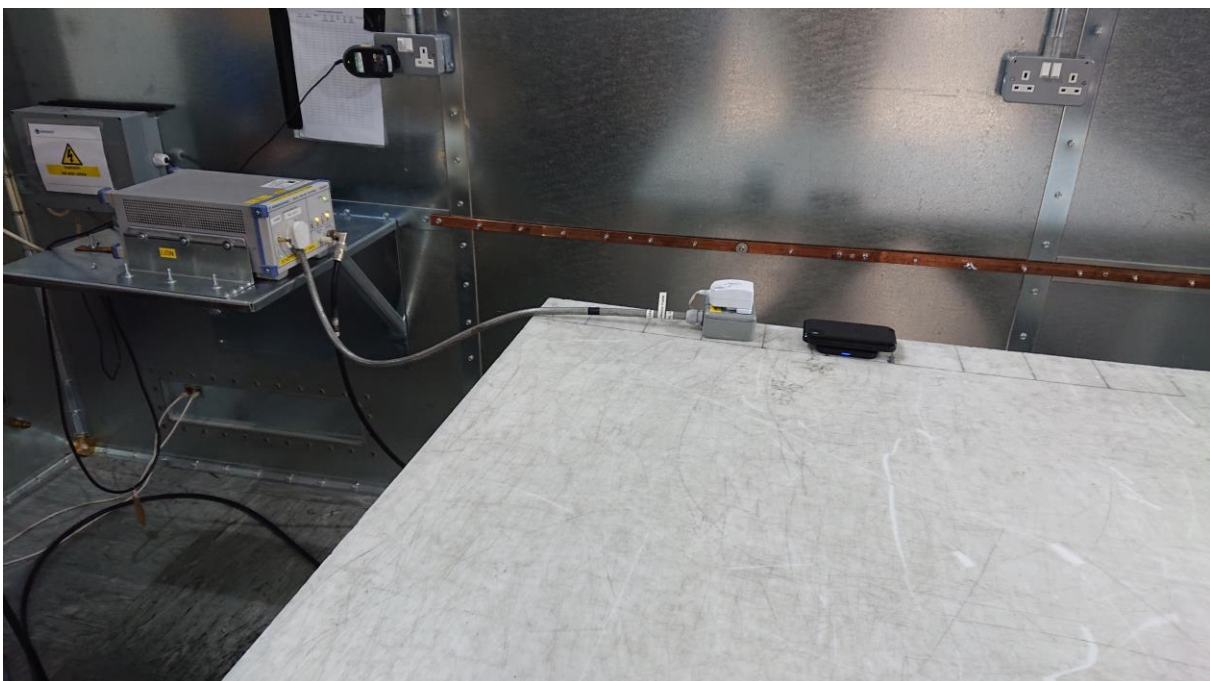

Test Setup - Mains Charger

**12.6 Test Equipment**

Equipment Type	Manufacturer	Equipment Description	Element No	Due For Calibration
ESR7	R&S	EMI Receiver	U456	2021-12-17
ENV216	R&S	Lisn	U396	2021-09-07
ESH3-Z2	R&S	Pulse Limiter	U443	2022-01-12

### 12.7 Test Results – Wireless Charger

CE LF Lab 150 kHz - 30 MHz (Auto Test) R X

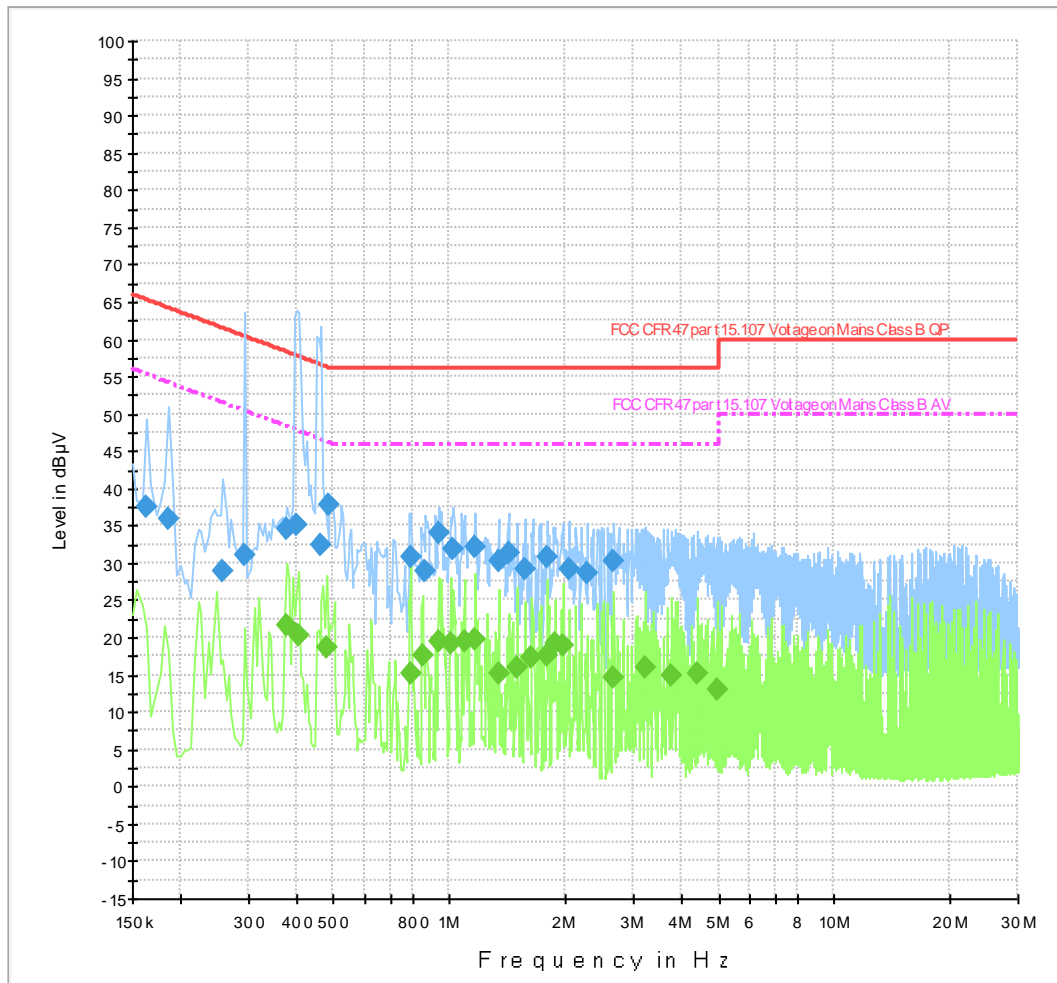

<i>Results measured using the quasi-peak detector</i>								
Frequency (MHz)	QuasiPeak (dBµV)	Meas. Time (ms)	Bandwidth (kHz)	Filter	Line	Corr. (dB)	Margin (dB)	Limit (dBµV)
0.163500	37.5	2000.0	9.000	On	L1	19.3	27.8	65.3
0.186000	35.9	2000.0	9.000	On	L1	19.3	28.3	64.2
0.258000	28.8	2000.0	9.000	On	L1	19.4	32.7	61.5
0.294000	31.0	2000.0	9.000	On	N	19.4	29.4	60.4
0.379500	34.6	2000.0	9.000	On	N	19.3	23.7	58.3
0.402000	35.0	2000.0	9.000	On	N	19.3	22.8	57.8
0.465000	32.3	2000.0	9.000	On	N	19.3	24.3	56.6
0.487500	37.7	2000.0	9.000	On	N	19.3	18.5	56.2
0.793500	30.8	2000.0	9.000	On	N	19.3	25.2	56.0
0.865500	29.0	2000.0	9.000	On	N	19.3	27.0	56.0
0.937500	33.9	2000.0	9.000	On	N	19.3	22.1	56.0
1.023000	31.9	2000.0	9.000	On	N	19.3	24.1	56.0
1.167000	32.2	2000.0	9.000	On	N	19.3	23.8	56.0
1.338000	30.2	2000.0	9.000	On	N	19.3	25.8	56.0
1.428000	31.3	2000.0	9.000	On	N	19.3	24.7	56.0
1.572000	29.3	2000.0	9.000	On	N	19.3	26.7	56.0
1.788000	30.8	2000.0	9.000	On	N	19.3	25.2	56.0
2.053500	29.2	2000.0	9.000	On	N	19.3	26.8	56.0
2.278500	28.6	2000.0	9.000	On	N	19.3	27.4	56.0
2.679000	30.2	2000.0	9.000	On	N	19.2	25.8	56.0

<i>Results measured using the quasi-peak detector</i>								
Frequency (MHz)	Average (dBµV)	Meas. Time (ms)	Bandwidth (kHz)	Filter	Line	Corr. (dB)	Margin (dB)	Limit (dBµV)
0.379500	21.5	2000.0	9.000	On	N	19.3	26.8	48.3
0.406500	20.3	2000.0	9.000	On	N	19.3	27.4	47.7
0.478500	18.7	2000.0	9.000	On	N	19.3	27.6	46.4
0.793500	15.0	2000.0	9.000	On	N	19.3	31.0	46.0
0.852000	17.6	2000.0	9.000	On	N	19.3	28.4	46.0
0.937500	19.4	2000.0	9.000	On	N	19.3	26.6	46.0
1.005000	19.1	2000.0	9.000	On	N	19.3	26.9	46.0
1.095000	19.5	2000.0	9.000	On	N	19.3	26.5	46.0
1.162500	19.7	2000.0	9.000	On	N	19.3	26.3	46.0
1.342500	15.2	2000.0	9.000	On	N	19.3	30.8	46.0
1.500000	15.9	2000.0	9.000	On	N	19.3	30.1	46.0
1.635000	17.4	2000.0	9.000	On	N	19.3	28.6	46.0
1.792500	17.6	2000.0	9.000	On	N	19.3	28.4	46.0
1.878000	19.1	2000.0	9.000	On	N	19.3	26.9	46.0
1.972500	18.9	2000.0	9.000	On	N	19.3	27.1	46.0
2.674500	14.5	2000.0	9.000	On	N	19.2	31.5	46.0
3.223500	16.0	2000.0	9.000	On	N	19.2	30.0	46.0
3.768000	14.8	2000.0	9.000	On	N	19.3	31.2	46.0
4.402500	15.2	2000.0	9.000	On	N	19.3	30.8	46.0
4.947000	13.0	2000.0	9.000	On	N	19.3	33.0	46.0

12.8 Test Results – Mains Charger

CE Chamber 2 150 kHz - 30 MHz (Auto Test) RX

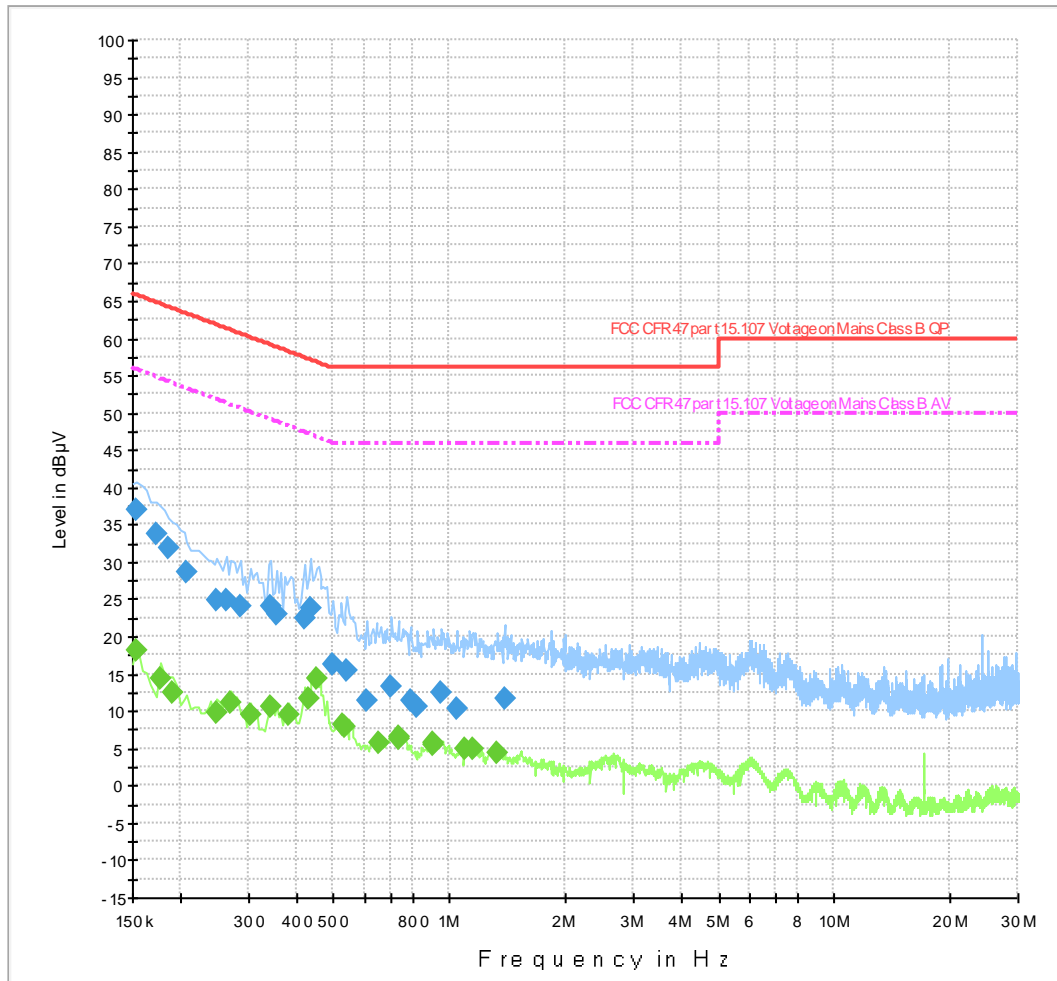

<b>Results measured using the quasi-peak detector</b>								
Frequency (MHz)	QuasiPeak (dBµV)	Meas. Time (ms)	Bandwidth (kHz)	Filter	Line	Corr. (dB)	Margin (dB)	Limit (dBµV)
0.154500	37.0	2000.0	9.000	GND	N	9.9	28.8	65.8
0.172500	33.7	2000.0	9.000	GND	L1	9.9	31.1	64.8
0.186000	31.9	2000.0	9.000	GND	L1	9.9	32.3	64.2
0.208500	28.6	2000.0	9.000	GND	L1	10.0	34.7	63.3
0.249000	24.8	2000.0	9.000	GND	L1	10.0	37.0	61.8
0.262500	24.7	2000.0	9.000	GND	L1	10.0	36.6	61.4
0.285000	24.1	2000.0	9.000	GND	L1	10.0	36.5	60.7
0.343500	24.1	2000.0	9.000	GND	L1	10.0	35.0	59.1
0.357000	23.0	2000.0	9.000	GND	L1	10.0	35.8	58.8
0.420000	22.4	2000.0	9.000	GND	L1	10.0	35.1	57.4
0.433500	23.7	2000.0	9.000	GND	L1	10.0	33.5	57.2
0.496500	16.2	2000.0	9.000	GND	L1	10.0	39.8	56.1
0.541500	15.4	2000.0	9.000	GND	N	10.0	40.6	56.0
0.609000	11.3	2000.0	9.000	GND	L1	10.0	44.7	56.0
0.708000	13.2	2000.0	9.000	GND	L1	10.0	42.8	56.0
0.793500	11.3	2000.0	9.000	GND	N	10.0	44.7	56.0
0.825000	10.7	2000.0	9.000	GND	L1	10.0	45.3	56.0
0.955500	12.5	2000.0	9.000	GND	L1	10.0	43.5	56.0
1.045500	10.3	2000.0	9.000	GND	N	10.0	45.7	56.0
1.387500	11.5	2000.0	9.000	GND	N	10.0	44.5	56.0

<b>Results measured using the quasi-peak detector</b>								
Frequency (MHz)	Average (dBµV)	Meas. Time (ms)	Bandwidth (kHz)	Filter	Line	Corr. (dB)	Margin (dB)	Limit (dBµV)
0.154500	18.2	2000.0	9.000	GND	L1	9.9	37.6	55.8
0.177000	14.4	2000.0	9.000	GND	L1	9.9	40.2	54.6
0.190500	12.5	2000.0	9.000	GND	L1	9.9	41.5	54.0
0.249000	9.9	2000.0	9.000	GND	L1	10.0	41.9	51.8
0.271500	11.2	2000.0	9.000	GND	L1	10.0	39.8	51.1
0.303000	9.5	2000.0	9.000	GND	L1	10.0	40.7	50.2
0.343500	10.5	2000.0	9.000	GND	L1	10.0	38.6	49.1
0.384000	9.5	2000.0	9.000	GND	L1	10.0	38.7	48.2
0.429000	11.7	2000.0	9.000	GND	L1	10.0	35.6	47.3
0.451500	14.5	2000.0	9.000	GND	L1	10.0	32.4	46.8
0.528000	8.1	2000.0	9.000	GND	L1	10.0	37.9	46.0
0.537000	7.8	2000.0	9.000	GND	L1	10.0	38.2	46.0
0.654000	5.8	2000.0	9.000	GND	L1	10.0	40.2	46.0
0.735000	6.5	2000.0	9.000	GND	L1	10.0	39.5	46.0
0.739500	6.4	2000.0	9.000	GND	L1	10.0	39.6	46.0
0.901500	5.5	2000.0	9.000	GND	L1	10.0	40.5	46.0
0.910500	5.7	2000.0	9.000	GND	L1	10.0	40.3	46.0
1.095000	4.8	2000.0	9.000	GND	L1	10.0	41.2	46.0
1.153500	5.0	2000.0	9.000	GND	L1	10.0	41.0	46.0
1.329000	4.4	2000.0	9.000	GND	L1	10.0	41.6	46.0

## 13 Occupied Bandwidth

### 13.1 Definition

The emission bandwidth (x dB) is defined as the frequency range between two points, one above and one below the carrier frequency, at which the spectral density of the emission is attenuated x dB below the maximum in-band spectral density of the modulated signal.

### 13.2 Test Parameters

Test Location:	Element Skelmersdale
Test Chamber:	Radio Laboratory
Test Standard and Clause:	ANSI C63.10-2013, Clause 11.8
EUT Channels / Frequencies Measured:	2402 MHz / 2440 MHz / 2480 MHz
EUT Channel Bandwidths:	2 MHz
EUT Test Modulations:	GFSK
Deviations From Standard:	None
Measurement BW:	6dB: 100 kHz
Spectrum Analyzer Video BW: (requirement at least 3x RBW)	6dB: 300 kHz
Measurement Span: (requirement 2 to 5 times OBW)	3 MHz
Measurement Detector:	Peak

### Environmental Conditions (Normal Environment)

Temperature: 22 °C	+15 °C to +35 °C (as declared)
Humidity: 34 % RH	20 % RH to 75 % RH (as declared)

### 13.3 Test Limit

The minimum -6 dB bandwidth shall be at least 500 kHz.



### 13.4 Test Method

With the EUT setup as per section 9 of this report and connected as per Figure iii, the bandwidth of the EUT was measured on a spectrum analyser.

The measurements were performed with EUT set at its maximum duty. All modulation schemes, data rates and power settings were used to observe the worst-case configuration in each bandwidth.

**Figure iii Test Setup**

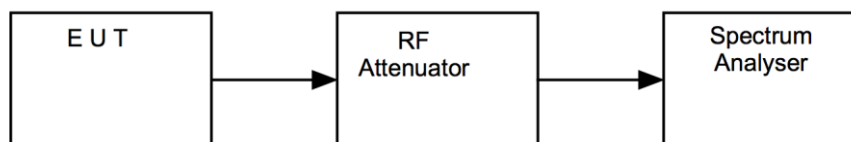

### 13.5 Test Equipment

Equipment Type	Manufacturer	Equipment Description	Element No	Due For Calibration
FSU26	R&S	Spectrum Analyser	U405	2021-07-17

### 13.6 Test Results

6 dB Bandwidth . Modulation: GFSK; Data rate: 1 Mbps; Power setting: 0 dBm				
Channel Frequency (MHz)	$F_L$ (MHz)	$F_H$ (MHz)	6dB Bandwidth (kHz)	Result
2402	2401.591346	2402.312500	721.154	PASS
2440	2439.591346	2440.312500	721.154	PASS
2480	2479.567308	2480.322115	754.807	PASS

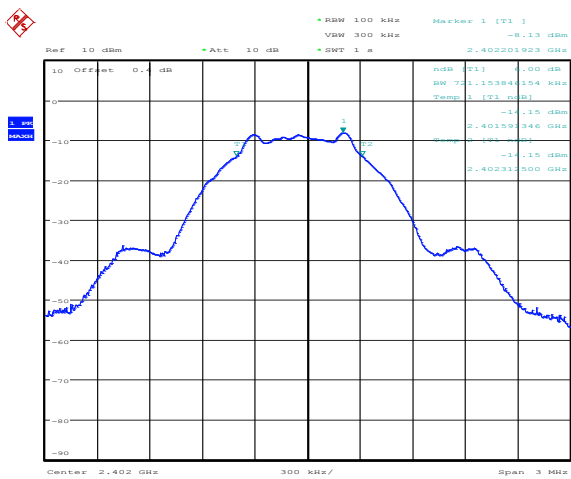

2402 MHz

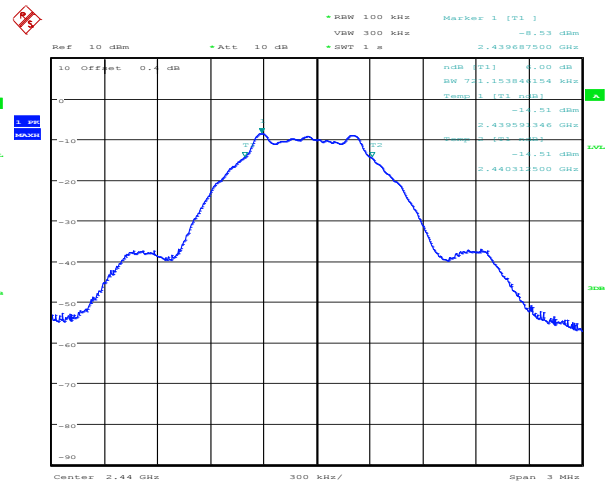

2440 MHz

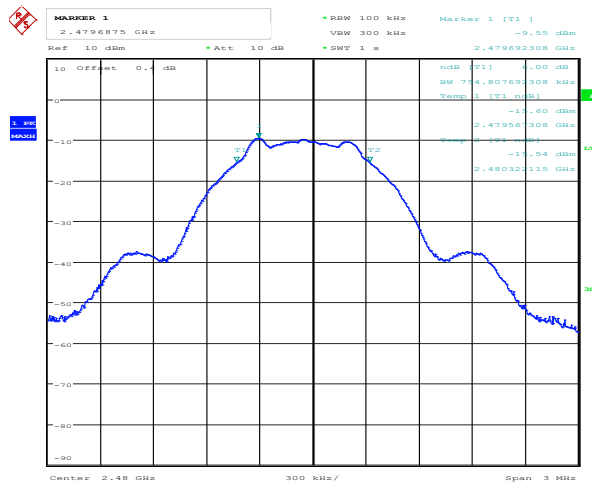

2480 MHz

## 14 Maximum peak conducted output power

### 14.1 Definition

The maximum peak conducted output power is defined as the maximum power level measured with a peak detector using a filter with width and shape of which is sufficient to accept the signal bandwidth.

The maximum conducted output power is defined as the total transmit power delivered to all antennas and antenna elements averaged across all symbols in the signaling alphabet when the transmitter is operating at its maximum power control level.

### 14.2 Test Parameters

Test Location:	Element Skelmersdale
Test Chamber:	Radio Laboratory
Test Standard and Clause:	ANSI C63.10-2013, Clause 11.9.1
EUT Channels / Frequencies Measured:	2402 MHz / 2440 MHz / 2480 MHz
EUT Channel Bandwidths:	2 MHz
Deviations From Standard:	None
Measurement BW:	2 MHz
Spectrum Analyzer Video BW: (requirement at least 3x RBW)	5 MHz
Measurement Detector:	Peak
Voltage Extreme Environment Test Range:	Battery Power = Fully charged.

### Environmental Conditions (Normal Environment)

Temperature: 22 °C	+15 °C to +35 °C (as declared)
Humidity: 34 % RH	20 % RH to 75 % RH (as declared)

### 14.3 Test Limit

For systems employing digital modulation techniques operating in the bands 902 to 928 MHz, 2400 to 2483.5 MHz and 5725 to 5850 MHz, the maximum peak conducted output power shall not exceed 1 W.

#### 14.4 Test Method

With the EUT setup as per section 9 of this report and connected as per Figure iv, the resolution bandwidth of the spectrum analyser was increased above the EUT occupied bandwidth and the peak emission data noted.

The measurements were performed with EUT set at its maximum duty. All modulation schemes, data rates and power settings were used to observe the worst-case configuration in each bandwidth.

**Figure iv Test Setup**

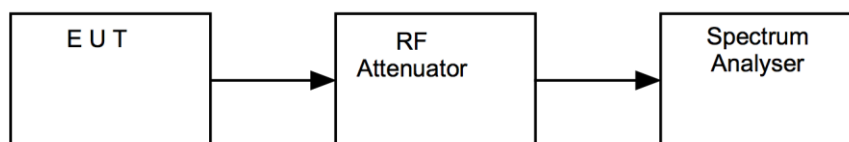

#### 14.5 Test Equipment

Equipment Type	Manufacturer	Equipment Description	Element No	Due For Calibration
FSU26	R&S	Spectrum Analyser	U405	2021-07-17

### 14.6 Test Results

Modulation: GFSK; Data rate: 1 Mbps; Power setting: 0 dBm							
Channel Frequency (MHz)	Analyzer Level (dBm)	Cable loss (dB)	Power (dBm)	Antenna Gain (dBi)	EIRP (dBm)	EIRP (mW)	Result
2402	-8.38	0.40	-7.98	3.27	-4.71	0.34	PASS
2440	-8.81	0.40	-8.41	3.27	-5.14	0.31	PASS
2480	-9.55	0.40	-9.15	3.27	-5.88	0.26	PASS

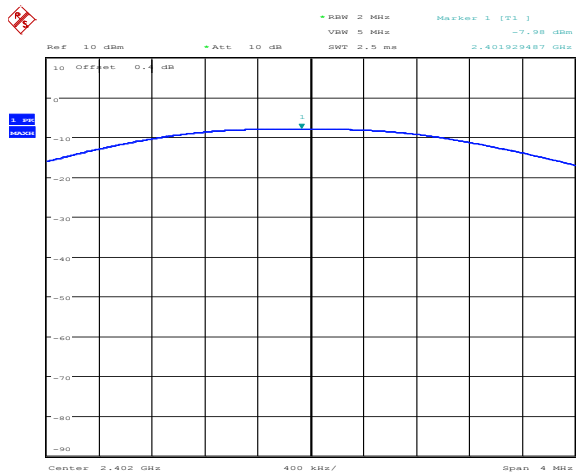

2402 MHz

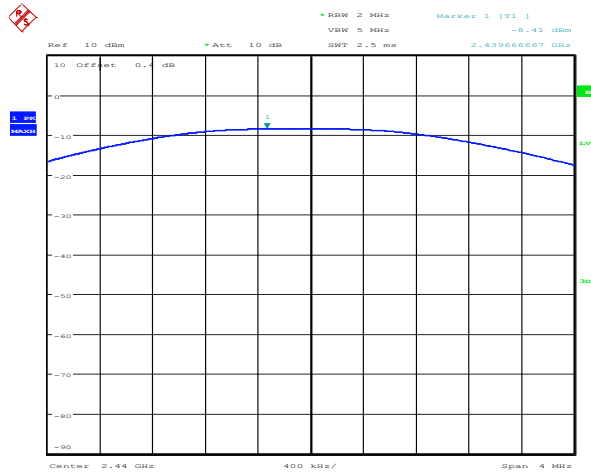

2440 MHz

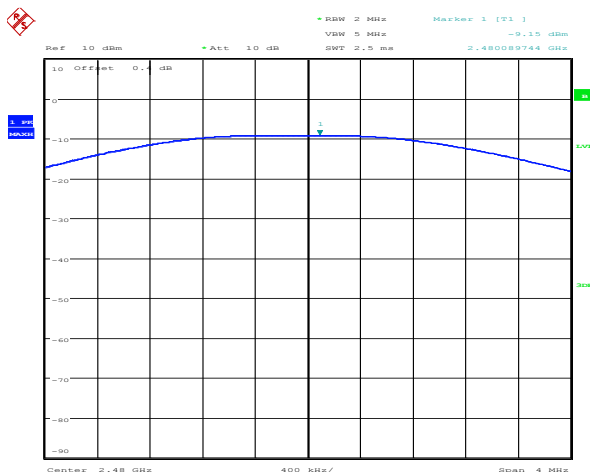

2480 MHz

## 15 Out-of-band and conducted spurious emissions

### 15.1 Definition

#### *Out-of-band emission.*

Emission on a frequency or frequencies immediately outside the necessary bandwidth that results from the modulation process but excluding spurious emissions.

#### *Spurious emission.*

Emission on a frequency or frequencies that are outside the necessary bandwidth and the level of which may be reduced without affecting the corresponding transmission of information. Spurious emissions include harmonic emissions, parasitic emissions, intermodulation products, and frequency conversion products, but exclude out-of-band emissions.

### 15.2 Test Parameters

Test Location:	Element Skelmersdale
Test Chamber:	Radio Laboratory
Test Standard and Clause:	ANSI C63.10-2013, Clause 11.11
EUT Frequencies Measured:	2402 MHz / 2440 MHz / 2480 MHz
EUT Channel Bandwidths:	2 MHz
Deviations From Standard:	None
Measurement BW:	100 kHz
Spectrum Analyzer Video BW: (requirement at least 3x RBW)	300 kHz
Measurement Detector:	Peak
Measurement Range:	9kHz to 26.5 GHz

### Environmental Conditions (Normal Environment)

Temperature: 22 °C	+15 °C to +35 °C (as declared)
Humidity: 34 % RH	20 % RH to 75 % RH (as declared)

### 15.3 Test Limit

In any 100 kHz bandwidth outside the frequency band in which the spread spectrum or digitally modulated device is operating, the RF power that is produced shall be at least 20 dB below that in the 100 kHz bandwidth within the band that contains the highest level of the desired power, based on either an RF conducted or a radiated measurement, provided that the transmitter demonstrates compliance with the peak conducted power limits. If the transmitter complies with the conducted power limits based on the use of root-mean-square averaging over a time interval, the attenuation required shall be 30 dB instead of 20 dB. Attenuation below the general field strength limits specified in FCC 47CFR15.209(a) / RSS-Gen is not required.

### 15.4 Test Method

With the EUT setup as per section 9 of this report and connected as per Figure v, the emissions from the EUT were measured on a spectrum analyser.

The measurements were performed with EUT set at its maximum duty. All modulation schemes, data rates and power settings were used to observe the worst case configuration in each bandwidth.

**Figure v Test Setup**

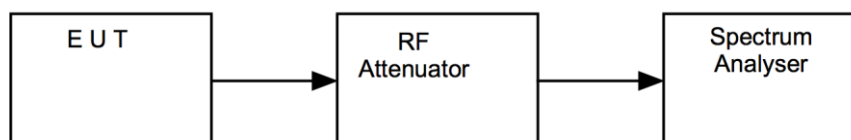

### 15.5 Test Equipment

Equipment Type	Manufacturer	Equipment Description	Element No	Due For Calibration
FSU26	R&S	Spectrum Analyser	U405	2021-07-17

### 15.6 Test Results

Frequency: 2402 MHz; Modulation: GFSK; Data rate: 1Mbps; Power setting:0 dBm						
Channel Frequency (MHz)	Emission Frequency (MHz)	Analyzer Level (dBm)	Emission Level (dBm)	Limit (dBm)	Margin (dB)	Result
Limit Reference		-8.13	-8.13	N/A	N/A	PASS

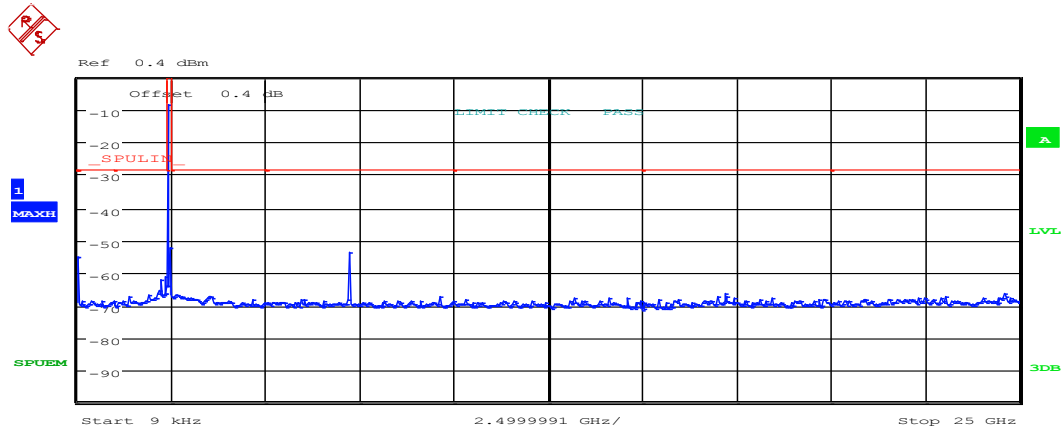

Start [Hz]	Stop [Hz]	RBW [Hz]	Freq [Hz]	PwrAbs [dBm]	Δ Limit [dB]
9.000 k	150.000 k	1.00 k	112.038462 k	-73.52	-45.37
150.000 k	30.000 M	10.00 k	508.200000 k	-55.09	-26.94
30.000 M	1.000 G	100.00 k	623.931000 M	-68.78	-40.63
1.000 G	2.400 G	100.00 k	2.337980 G	-61.21	-33.06
2.400 G	2.483 G	2.00 M	2.401628 G	-8.24	-28.24
2.483 G	5.000 G	100.00 k	2.659655 G	-66.67	-38.52
5.000 G	10.000 G	100.00 k	7.205000 G	-53.97	-25.82
10.000 G	15.000 G	100.00 k	14.588000 G	-67.70	-39.55
15.000 G	20.000 G	100.00 k	17.195000 G	-66.32	-38.17
20.000 G	25.000 G	100.00 k	24.580500 G	-66.69	-38.54

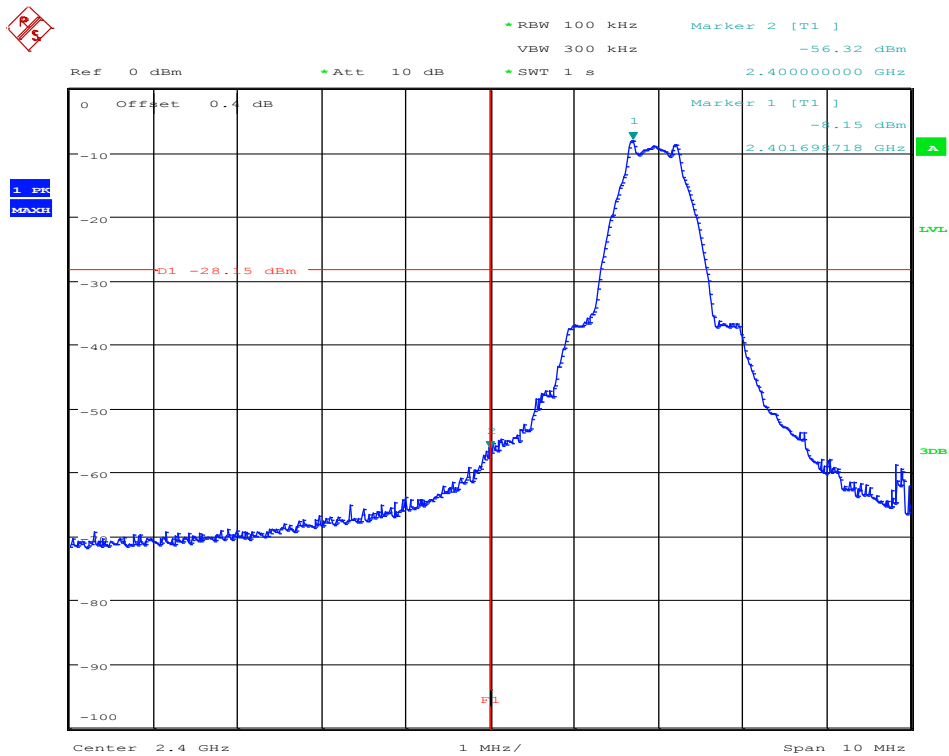



Frequency: 2440 MHz; Modulation: GFSK; Data rate: 1Mbps; Power setting:0 dBm						
Channel Frequency (MHz)	Emission Frequency (MHz)	Analyzer Level (dBm)	Emission Level (dBm)	Limit (dBm)	Margin (dB)	Result
Limit Reference		-8.13	-8.13	N/A	N/A	PASS

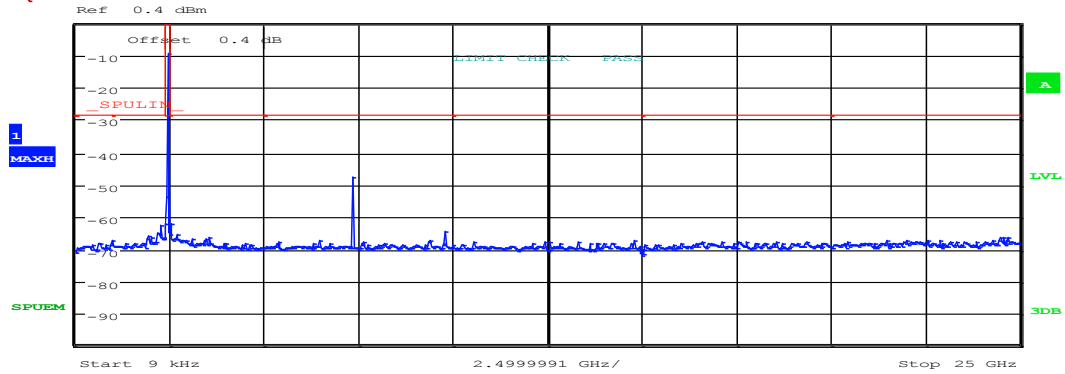

Start [Hz]	Stop [Hz]	RBW [Hz]	Freq [Hz]	PwrAbs [dBm]	Δ Limit [dB]
9.000 k	150.000 k	1.00 k	9.000000 k	-77.90	-49.75
150.000 k	30.000 M	10.00 k	176.865000 k	-71.11	-42.96
30.000 M	1.000 G	100.00 k	994.762000 M	-67.25	-39.10
1.000 G	2.400 G	100.00 k	2.375920 G	-62.06	-33.91
2.400 G	2.483 G	2.00 M	2.439629 G	-9.02	-29.02
2.483 G	5.000 G	100.00 k	2.503884 G	-62.47	-34.32
5.000 G	10.000 G	100.00 k	7.319000 G	-47.59	-19.44
10.000 G	15.000 G	100.00 k	14.763500 G	-67.61	-39.46
15.000 G	20.000 G	100.00 k	16.574500 G	-67.83	-39.68
20.000 G	25.000 G	100.00 k	24.659000 G	-66.41	-38.26

Frequency: 2440 MHz; Modulation: GFSK; Data rate: 1Mbps; Power setting:0 dBm						
Channel Frequency (MHz)	Emission Frequency (MHz)	Analyzer Level (dBm)	Emission Level (dBm)	Limit (dBm)	Margin (dB)	Result
Limit Reference		-8.13	-8.13	N/A	N/A	PASS

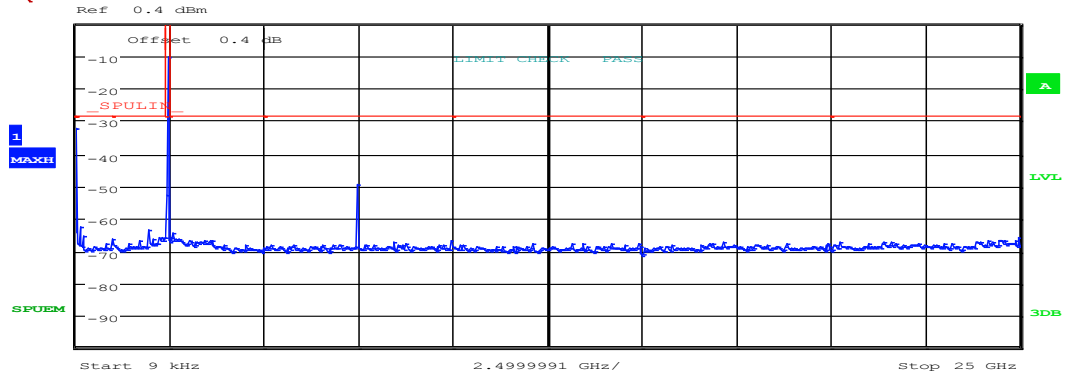

Start [Hz]	Stop [Hz]	RBW [Hz]	Freq [Hz]	PwrAbs [dBm]	Δ Limit [dB]
9.000 k	150.000 k	1.00 k	57.807692 k	-41.52	-13.37
150.000 k	30.000 M	10.00 k	403.725000 k	-32.05	-3.90
30.000 M	1.000 G	100.00 k	102.362000 M	-62.78	-34.63
1.000 G	2.400 G	100.00 k	1.936180 G	-63.66	-35.51
2.400 G	2.483 G	2.00 M	2.479784 G	-9.96	-29.96
2.483 G	5.000 G	100.00 k	2.543896 G	-64.43	-36.28
5.000 G	10.000 G	100.00 k	7.439000 G	-49.74	-21.59
10.000 G	15.000 G	100.00 k	12.112500 G	-67.73	-39.58
15.000 G	20.000 G	100.00 k	17.166500 G	-67.48	-39.33
20.000 G	25.000 G	100.00 k	24.942500 G	-66.23	-38.08

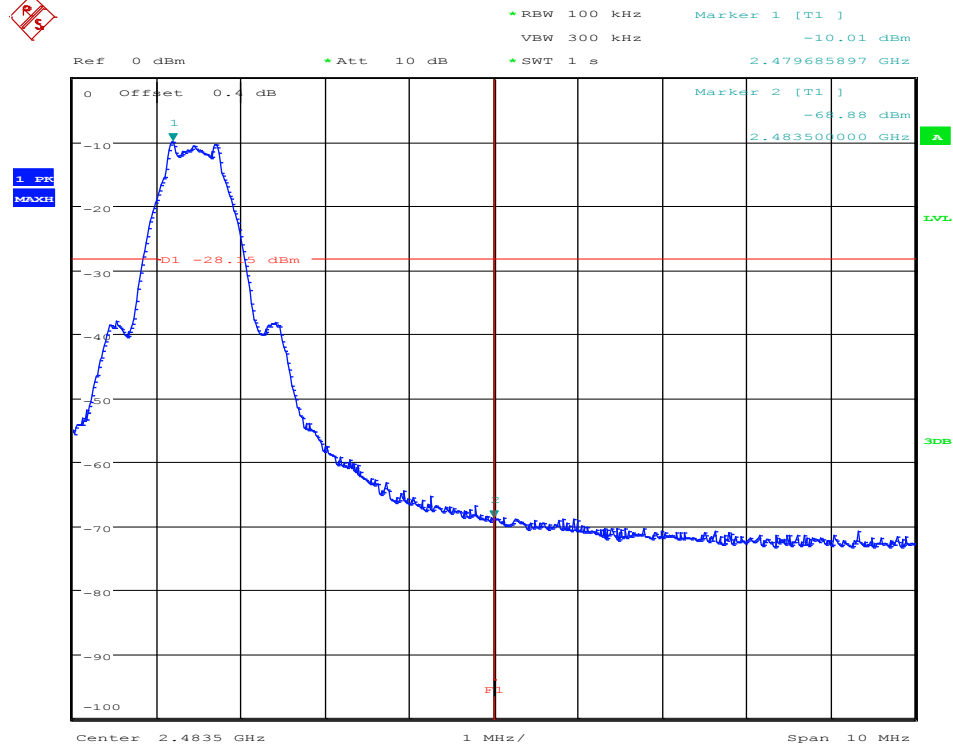

## 16 Power spectral density

### 16.1 Definition

The power per unit bandwidth.

### 16.2 Test Parameters

Test Location:	Element Skelmersdale
Test Chamber:	Radio Laboratory
Test Standard and Clause:	ANSI C63.10-2013, Clause 11.10
EUT Channels / Frequencies Measured:	2402 MHz / 2440 MHz / 2480 MHz
EUT Channel Bandwidths:	2 MHz
Deviations From Standard:	GFSK
Measurement BW:	100 kHz
Spectrum Analyzer Video BW: (requirement at least 3x RBW)	300 kHz
Measurement Span: (requirement 1.5 times Channel BW)	1.2 MHz
Measurement Detector:	Peak

### Environmental Conditions (Normal Environment)

Temperature: 22 °C	+15 °C to +35 °C (as declared)
Humidity: 34 % RH	20 % RH to 75 % RH (as declared)

### 16.3 Test Limit

The transmitter power spectral density conducted from the transmitter to the antenna shall not be greater than 8 dBm in any 3 kHz band during any time interval of continuous transmission.

#### 16.4 Test Method

With the EUT setup as per section 9 of this report and connected as per Figure vi, the peak emission of the EUT was measured on a spectrum analyser, with path losses taken into account.

The measurements were performed with EUT set at its maximum duty. All modulation schemes, data rates and power settings were used to observe the worst case configuration in each bandwidth.

**Figure vi Test Setup**

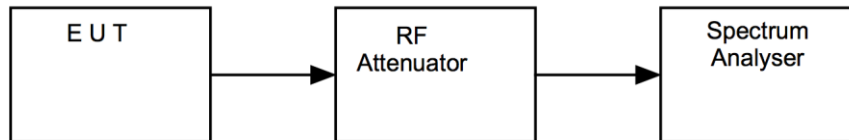

#### 16.5 Test Equipment

Equipment Type	Manufacturer	Equipment Description	Element No	Due For Calibration
FSU26	R&S	Spectrum Analyser	U405	2021-07-17

### 16.6 Test Results

Modulation: GFSK; Data rate: 1 Mbps; Power setting: 0 dBm				
Channel Frequency (MHz)	Analyzer Level (dBm)	Cable loss (dB)	Power (dBm)	Result
2402	-8.77	0.40	-8.37	PASS
2440	-9.18	0.40	-8.78	PASS
2480	-9.94	0.40	-9.54	PASS

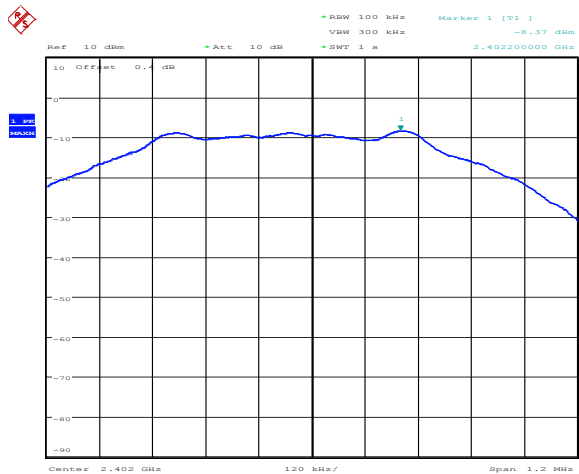

2402 MHz

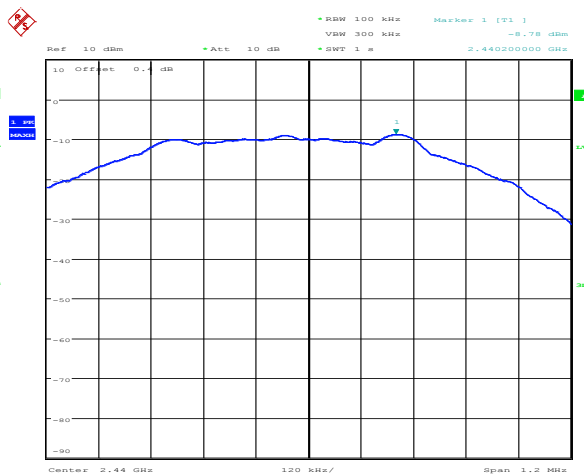

2440 MHz

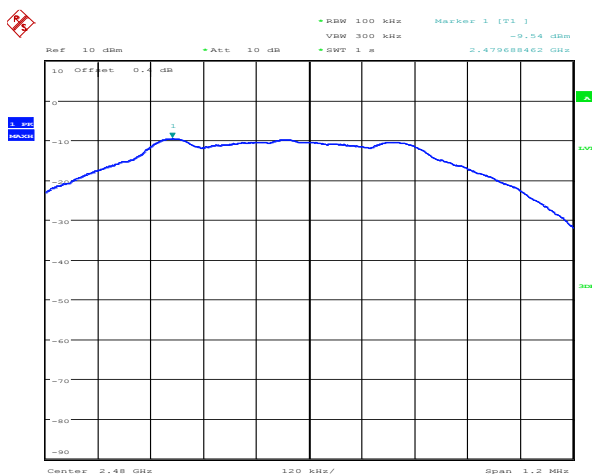

2480 MHz

## 17 Radiated emissions – unintentional radiation / receiver emissions

### 17.1 Definitions

#### *Receiver spurious emissions*

The radio frequency signals generated within the receiver, which may cause interference to other equipment. This includes the period during which the equipment is scanning or switching channels.

#### *Unintentional radiator*

A device that generates RF energy which is not intended to be radiated for reception by a radio receiver.

### 17.2 Test Parameters

Test Location:	Element Skelmersdale
Test Chamber:	Chamber 01
Test Standard and Clause:	ANSI C63.10-2013, Clause 6.5 and 6.6
EUT Channels / Frequencies Measured:	2402 MHz, 2440 MHz, 2480 MHz
Deviations From Standard:	None
Measurement BW:	30 MHz to 1 GHz: 120 kHz; Above 1 GHz: 1 MHz
Measurement Detector:	Up to 1 GHz: quasi-peak; Above 1 GHz: Peak

### Environmental Conditions (Normal Environment)

Temperature: 19 °C	+15 °C to +35 °C (as declared)
Humidity: 38 % RH	20 % RH to 75 % RH (as declared)
Supply: 3.7 V dc	230 V ac $\pm$ 10 % (as declared)

### 17.3 Test Limit

Note:

Only radio communication receivers operating in stand-alone mode within the band 30 to 960 MHz, as well as scanner receivers, are subject to requirements, as described above. All other receivers are exempted from any certification, testing, labelling and reporting requirements.

However, all receivers in all frequency bands shall comply with the limits set forth in FCC 47CFR15B / IC RSS-Gen even in cases where testing, reporting and/or certification are not required.

### Receiver Radiated Limits

<i>Frequency (MHz)</i>	<i>Field Strength (<math>\mu</math>V/m at 3 m)</i>
30 to 88	100
88 to 216	150
216 to 960	200
Above 960	500

## 17.4 Test Method

With the EUT setup as per section 9 of this report and connected as per Figure viii, the emissions from the EUT were measured on a spectrum analyzer / EMI receiver. The EUT was rotated in three orthogonal planes and the measurement antenna height scanned (below 1 GHz, from 1 to 4 m; above 1 GHz as necessary) in order to maximise emissions.

The measurements were performed with EUT set at its maximum duty. All modulation schemes, data rates and power settings were used to observe the worst-case configuration at each frequency. Pre-scan plots are shown with a peak detector and 100 kHz RBW.

Figure viii Test Setup

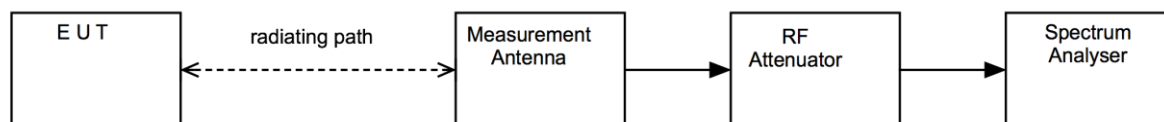

Test Setup Photograph(s)

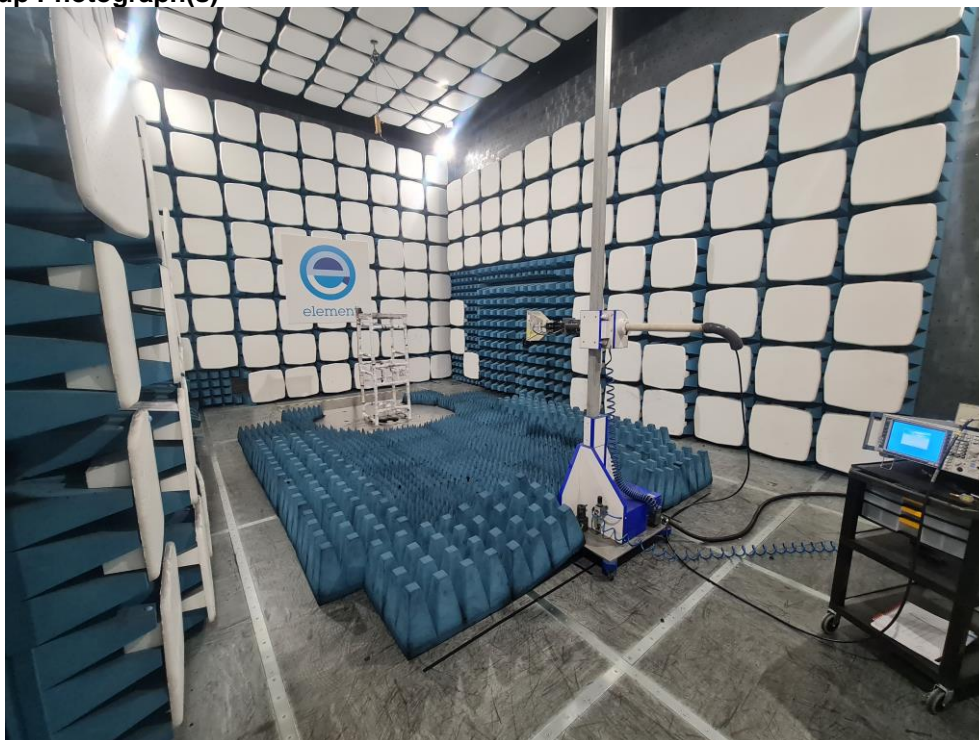



### 17.5 Test Equipment

<i>Equipment Description</i>	<i>Manufacturer</i>	<i>Equipment Type</i>	<i>Element No</i>	<i>Due For Calibration</i>
Radiated Test Software	Element	Emissions R5	REF9000	Cal not required
Signal Generator	R&S	SMB100A	U677	2022-01-26
Chamber 1	Rainford EMC	ATS	U387	2021-09-09
Pre Amp	Agilent	8449B	L572	2021-10-19
PreAmp	Watkins Johnson	6201-69	U372	2022-03-01
Bilog	Chase	CBL611/A	U573	2023-01-28
1-18GHz Horn	EMCO	3115	U223	2021-11-05
2.4G Band Stop Filter	BSC	SN 4478	U543	2022-01-30
1-18GHz Horn	EMCO	3115	L139	2021-07-16
Spectrum Analyser	R&S	FSW 26.5	*101805	2021-07-23
Spectrum Analyser	R&S	FSU26	U405	2021-07-17
Loop Antenna	R&S	hfh2	L007	2021-07-09

\*Denotes serial number of hired test equipment



17.6 Test Results – HFR4 – Mains Charger

Mains Charger: 110 V, 60 Hz: Bottom Channel: 2402 MHz; Receive mode									
Detector	Freq. (MHz)	Measured Emission (dB $\mu$ V/m)	Cable Loss (dB)	Antenna Factor (dB/m)	Pre-amp Gain (dB)	Field Strength (dB $\mu$ V/m)	Extrap'n Factor (dB)	Field Strength ( $\mu$ V/m)	Limit ( $\mu$ V/m)
No Emissions within 10 dB of the limit were detected.									

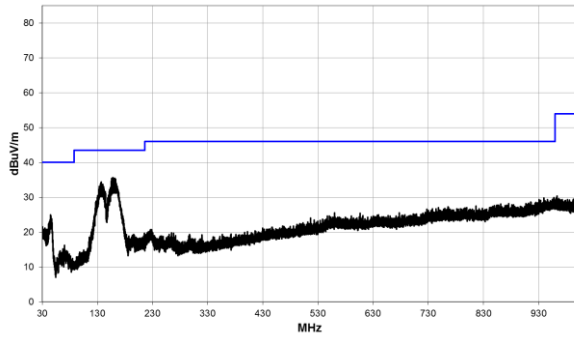

30 MHz to 1 GHz

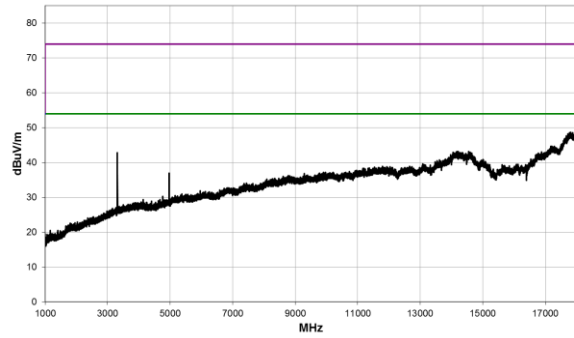

1 GHz to 18 GHz

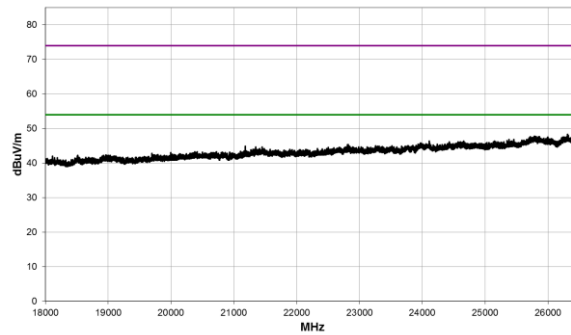

7 GHz to 18 GHz

Mains Charger: 110 V, 60 Hz: Middle Channel: 2440 MHz; Receive mode									
Detector	Freq. (MHz)	Measured Emission (dB $\mu$ V/m)	Cable Loss (dB)	Antenna Factor (dB/m)	Pre-amp Gain (dB)	Field Strength (dB $\mu$ V/m)	Extrap'n Factor (dB)	Field Strength ( $\mu$ V/m)	Limit ( $\mu$ V/m)
No Emissions within 10 dB of the limit were detected.									

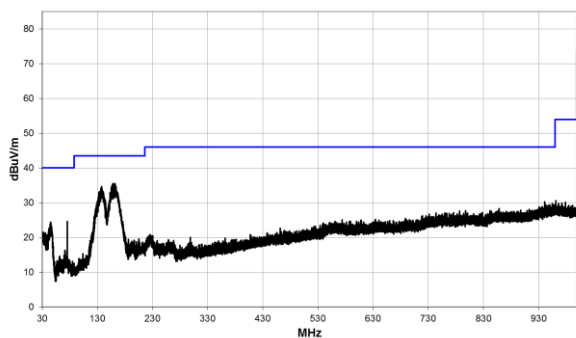

30 MHz to 1 GHz

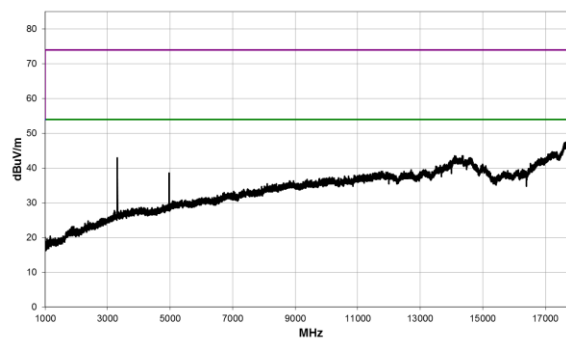

1 GHz to 18 GHz

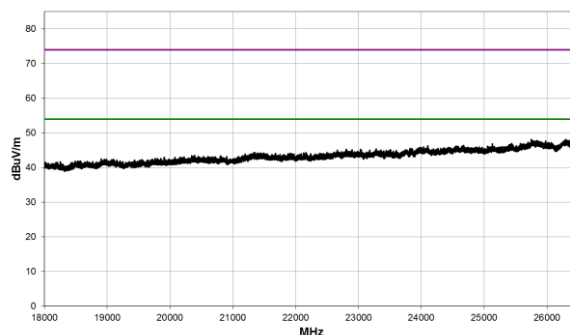

18 GHz to 26.5 GHz

Mains Charger: 110 V, 60 Hz: Top Channel: 2480 MHz; Receive mode									
Detector	Freq. (MHz)	Measured Emission (dB $\mu$ V/m)	Cable Loss (dB)	Antenna Factor (dB/m)	Pre-amp Gain (dB)	Field Strength (dB $\mu$ V/m)	Extrap'n Factor (dB)	Field Strength ( $\mu$ V/m)	Limit ( $\mu$ V/m)
No Emissions within 10 dB of the limit were detected.									

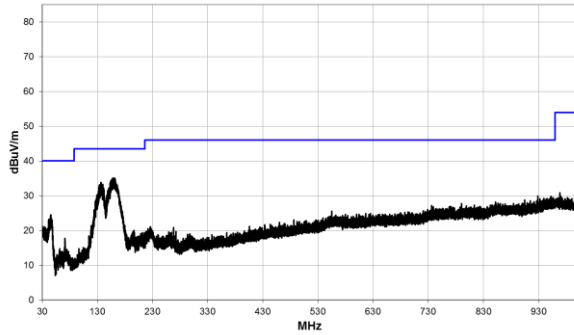

30 MHz to 1 GHz

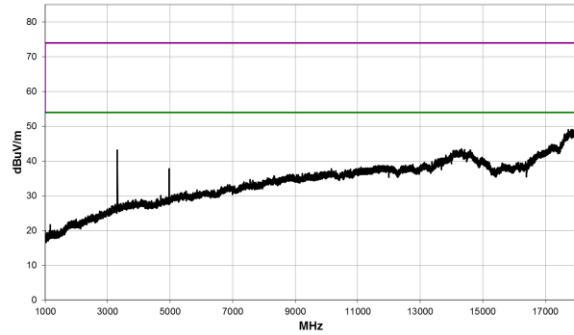

1 GHz to 18 GHz

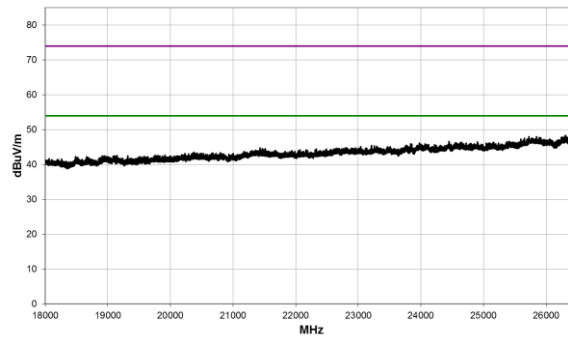

18 GHz to 26.5 GHz

### 17.7 Test Results – HGR4 – Wireless Charger

Wireless Charger; Bottom Channel: 2402 MHz; Receive mode									
Detector	Freq. (MHz)	Measured Emission (dB $\mu$ V/m)	Cable Loss (dB)	Antenna Factor (dB/m)	Pre-amp Gain (dB)	Field Strength (dB $\mu$ V/m)	Extrap'n Factor (dB)	Field Strength ( $\mu$ V/m)	Limit ( $\mu$ V/m)
No Emissions within 10 dB of the limit were detected.									

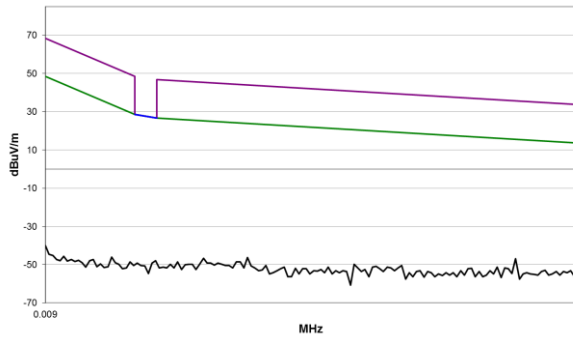

9 kHz to 490 kHz

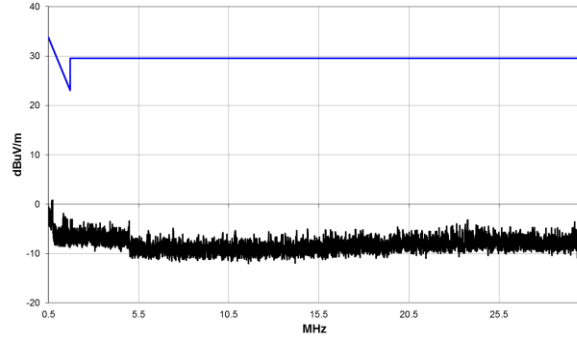

490 kHz to 30 MHz

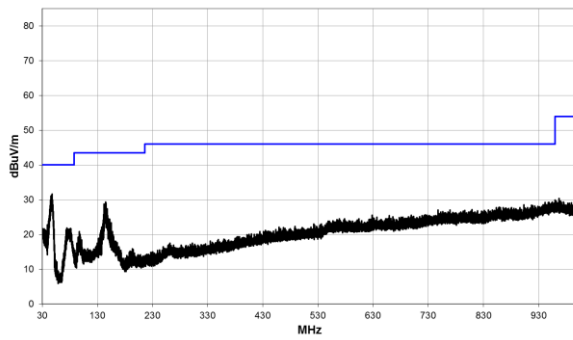

30 MHz to 1 GHz

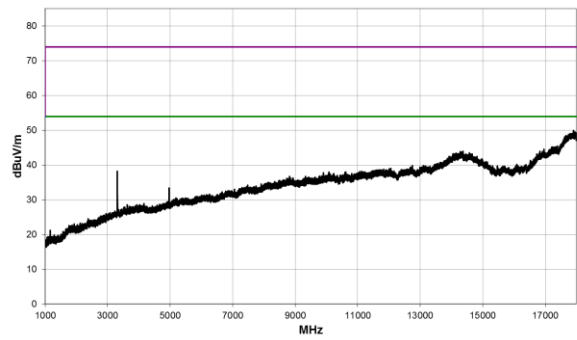

1 GHz to 18 GHz

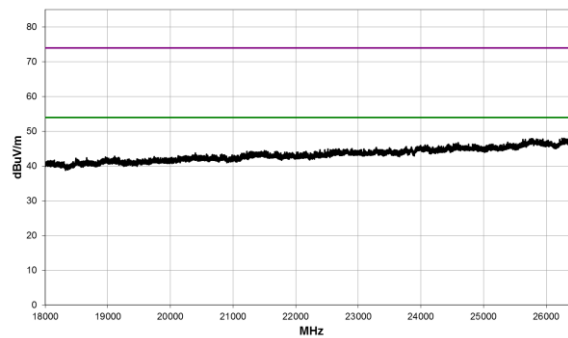

18 GHz to 26.5 GHz

Wireless Charger; Middle Channel: 2440 MHz; Receive mode									
Detector	Freq. (MHz)	Measured Emission (dB $\mu$ V/m)	Cable Loss (dB)	Antenna Factor (dB/m)	Pre-amp Gain (dB)	Field Strength (dB $\mu$ V/m)	Extrap'n Factor (dB)	Field Strength ( $\mu$ V/m)	Limit ( $\mu$ V/m)
No Emissions within 10 dB of the limit were detected.									

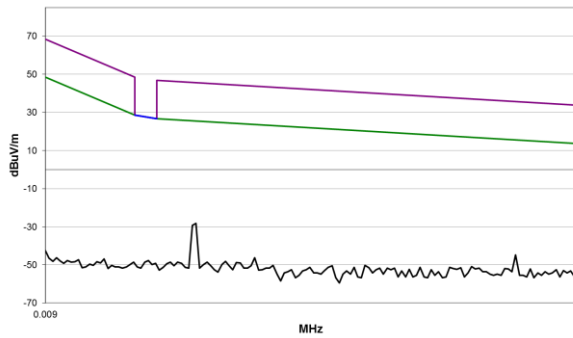

9 kHz to 490 kHz

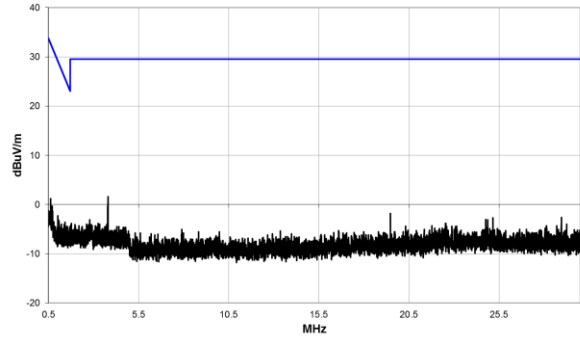

490 kHz to 30 MHz

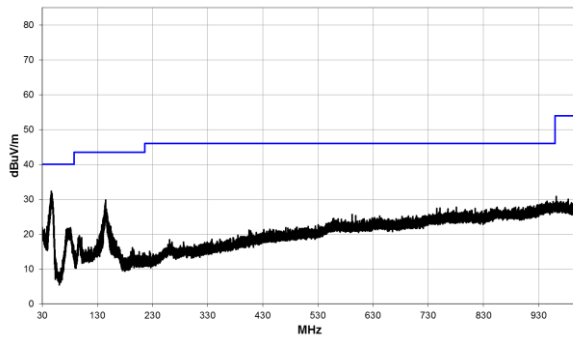

30 MHz to 1 GHz

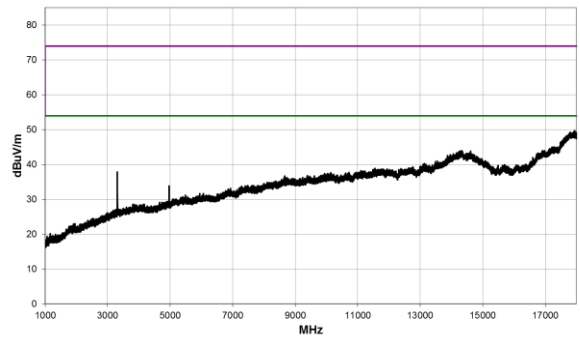

1 GHz to 18 GHz

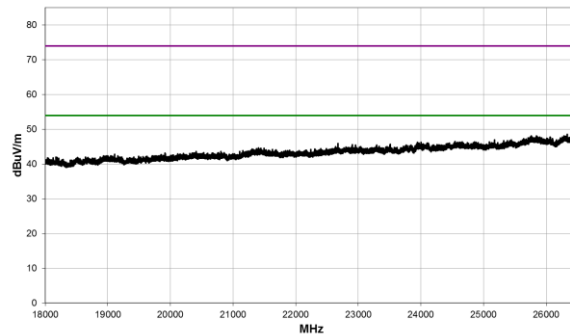

18 GHz to 26.5 GHz

**Wireless Charger; Top Channel: 2480 MHz; Receive mode**

Detector	Freq. (MHz)	Measured Emission (dB $\mu$ V/m)	Cable Loss (dB)	Antenna Factor (dB/m)	Pre-amp Gain (dB)	Field Strength (dB $\mu$ V/m)	Extrap'n Factor (dB)	Field Strength ( $\mu$ V/m)	Limit ( $\mu$ V/m)
No Emissions within 10 dB of the limit were detected.									

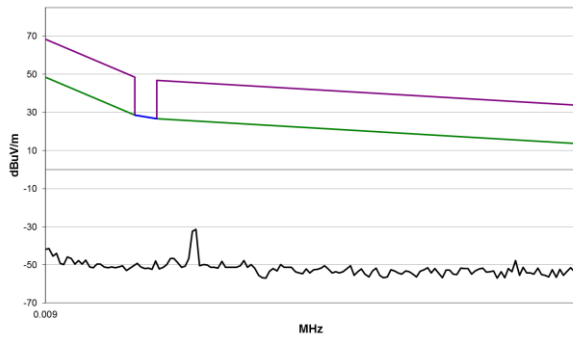

9 kHz to 490 kHz

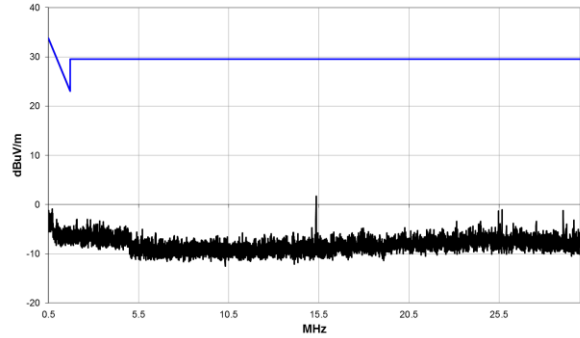

490 kHz to 30 MHz

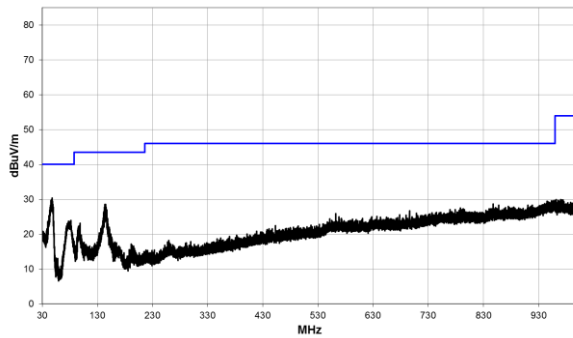

30 MHz to 1 GHz

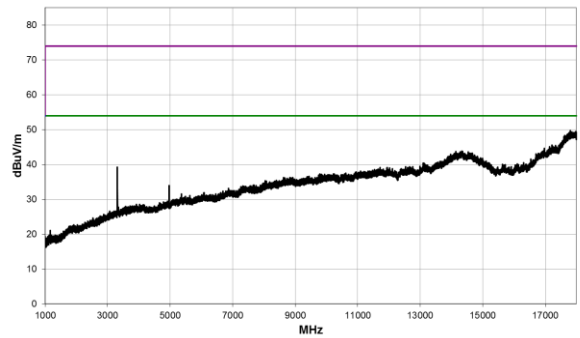

1 GHz to 18 GHz

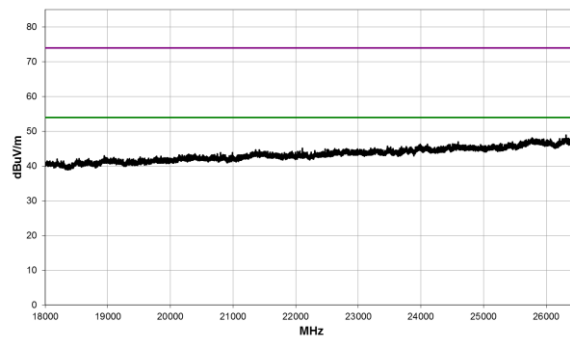

18 GHz to 26.5 GHz

## 18 Measurement Uncertainty

### Radio Testing – General Uncertainty Schedule

All statements of uncertainty are expanded standard uncertainty using a coverage factor of 1.96 to give a 95 % confidence where no required test level exists.

Reference No.	Parameter	Description	Value	Unit
1	Adjacent Channel Power	Uncertainty in test result	Error! Not a valid link.	dB
2	Carrier Power	Uncertainty in test result (Power Meter) Uncertainty in test result (Spectrum Analyser)	<b>0.070</b> Error! Not a valid link.	dB
3	Effective Radiated Power	Uncertainty in test result	<b>4.71</b>	dB
4	Radiated Spurious Emissions	Uncertainty in test result 30 MHz to 1 GHz 1 GHz to 18 GHz	<b>4.75</b> <b>4.46</b>	dB
5	Maximum Frequency Error	Uncertainty in test result (CMTA)	<b>113.441</b>	Hz
6	Radiated Emissions, Field Strength OATS 9 kHz – 110 GHz Electric Field	Uncertainty in test result (9 kHz – 30 MHz) Uncertainty in test result (30 MHz – 1 GHz) Uncertainty in test result (1 GHz – 18 GHz) Uncertainty in test result (18 GHz – 26 GHz) Uncertainty in test result (26 GHz – 40 GHz) Uncertainty in test result (40 GHz – 50 GHz) Uncertainty in test result (50 GHz – 75 GHz) Uncertainty in test result (75 GHz – 110 GHz)	<b>2.3</b> <b>4.75</b> <b>4.46</b> <b>3.2</b> <b>3.3</b> <b>3.5</b> <b>3.6</b> <b>3.6</b>	dB
7	Frequency Deviation	Uncertainty in test result	<b>3.7</b>	%
8	Magnetic Field Emissions	Uncertainty in test result	<b>2.3</b>	dB
9	Conducted Spurious	Uncertainty in test result Up to 26 GHz	<b>0.921</b>	dB
10	Channel Bandwidth	Uncertainty in test result	Error! Not a valid link.	%

Reference No.	Parameter	Description	Value	Unit
11	Spectrum Mask Measurements	Uncertainty in test result (frequency)	<b>2.59</b>	%
		Uncertainty in test result (amplitude)	<b>1.32</b>	dB
12	Adjacent Sub Band Selectivity	Uncertainty in test result	<b>1.24</b>	dB
13	Receiver Blocking – Listen Mode, Radiated	Uncertainty in test result	<b>3.23</b>	dB
14	Receiver Blocking – Talk Mode, Radiated	Uncertainty in test result	<b>3.36</b>	dB
15	Receiver Blocking – Talk Mode, Conducted	Uncertainty in test result	<b>1.24</b>	dB
16	Receiver Threshold	Uncertainty in test result	<b>3.42</b>	dB
17	Transmission Time Measurement	Uncertainty in test result	<b>4.40</b>	%



## 19 MPE Calculation

### Prediction of MPE limit at a given distance

For purposes of these requirements mobile devices are defined by the FCC as transmitters designed to be used in other than fixed locations and to generally be used in such a way that a separation distance of at least 20 centimeters is normally maintained between radiating structures and the body of the user or nearby persons. These devices are normally evaluated for exposure potential with relation to the MPE limits. As the 20 cm separation specified under FCC rules may not be achievable under normal operation of the EUT, an RF exposure calculation is needed to show the minimum distance required to be less than the power density limit, as required under FCC rules.

Equation from IEEE C95.1

$$S = \frac{EIRP}{4\pi R^2} \text{ re - arranged } R = \sqrt{\frac{EIRP}{S4\pi}}$$

Where:

S = power density

R = distance to the centre of radiation of the antenna

EIRP = EUT Maximum power

Result

<b>Channel Frequency (MHz)</b>	<b>EIRP (mW)</b>	<b>Power density limit (S) (mW/cm<sup>2</sup>)</b>	<b>Distance (R) cm required to be less than the power density limit</b>
2402	0.3	1.0	0.2
2440	0.3	1.0	0.2
2480	0.3	1.0	0.1