

## FCC PART 22/24/27 TEST REPORT

### FCC Part 22H/Part 24E/Part 27

<b>Report Reference No.</b> .....	<b>LCS201224030AEI</b>
<b>FCC ID.</b> .....	<b>2AYKD-TB8</b>
<b>Date of Issue</b> .....	<b>January 28, 2021</b>
<b>Testing Laboratory Name</b> .....	<b>Shenzhen LCS Compliance Testing Laboratory Ltd.</b>
<b>Address</b> .....	101, 201 Bldg A & 301 Bldg C, Juji Industrial Park Yabianxueziwei, Shajing Street, Baoan District, Shenzhen, 518000, China
<b>Applicant's name</b> .....	<b>Shanghai Armour Technology Co., Ltd.</b>
<b>Address</b> .....	Room 411, building 10, 471 Guiping Road, Xuhui District, Shanghai, China
<b>Test specification</b> .....	<b>FCC CFR Title 47 Part 2, Part 22H, Part 24E, Part 27</b>
<b>Standard</b> .....	<b>TIA-603-E: 2016</b>
	<b>KDB971168 D01 Power Meas License Digital Systems v03r01</b>
<b>Test Report Form No.</b> .....	LCSEMC-1.0
<b>TRF Originator</b> .....	Shenzhen LCS Compliance Testing Laboratory Ltd.
<b>Master TRF</b> .....	Dated 2011-03
<b>Shenzhen LCS Compliance Testing Laboratory Ltd. All rights reserved.</b>	
This publication may be reproduced in whole or in part for non-commercial purposes as long as the Shenzhen LCS Compliance Testing Laboratory Ltd. is acknowledged as copyright owner and source of the material. Shenzhen LCS Compliance Testing Laboratory Ltd. takes no responsibility for and will not assume liability for damages resulting from the reader's interpretation of the reproduced material due to its placement and context.	
<b>Test item description</b> .....	<b>TABLET</b>
<b>Trade Mark</b> .....	armourphone
<b>Test Model</b> .....	TB8
<b>Modulation Type</b> .....	QPSK, 16QAM
	DC 3.8V by Rechargeable Li-ion Battery, 9000mAh
<b>Rating</b> .....	For Adapter Input: AC 100-240V, 50/60Hz, 0.35A Max Adapter Output: DC 5.0V, 2A
<b>Hardware version</b> .....	HW_V1.0
<b>Software version</b> .....	Android10_TB8_V1_0
<b>Result</b> .....	<b>PASS</b>

**Compiled by:**

**Supervised by:**

**Approved by:**



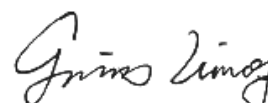

Jin Wang/ Administrator

Linda He/ Technique principal

Gavin Liang/ Manager

**TEST REPORT**

<b>Test Report No. :</b> <b>LCS201224030AEI</b>	January 28, 2021
	Date of issue

Equipment under Test        :        TABLET

Test Model                    :        TB8

**Applicant**                    :        **Shanghai Armour Technology Co., Ltd.**

Address                        :        Room 411, building 10, 471 Guiping Road, Xuhui District,  
Shanghai, China

**Manufacturer**                :        **Shanghai Armour Technology Co., Ltd.**

Address                        :        Room 411, building 10, 471 Guiping Road, Xuhui District,  
Shanghai, China

**Factory**                        :        /

Address                        :        /

<b>Test Result:</b>	<b>PASS</b>
---------------------	-------------

The test report merely corresponds to the test sample.  
It is not permitted to copy extracts of these test result without the written permission of the test laboratory.

### Revision History

Revision	Issue Date	Revisions	Revised By
000	January 28, 2021	Initial Issue	Gavin Liang

## Contents

<b><u>1</u></b>	<b><u>TEST STANDARDS.....</u></b>	<b><u>5</u></b>
<b><u>2</u></b>	<b><u>SUMMARY.....</u></b>	<b><u>6</u></b>
2.1	General Remarks	6
2.2	Product Description	6
2.3	Equipment under Test	9
2.4	Short description of the Equipment under Test (EUT)	9
2.5	Internal Identification of AE used during the test	9
2.6	EUT configuration	9
2.7	Related Submittal(s) / Grant (s)	9
2.8	Modifications	9
2.9	General Test Conditions/Configurations	10
<b><u>3</u></b>	<b><u>TEST ENVIRONMENT .....</u></b>	<b><u>11</u></b>
3.1	Address of the test laboratory	11
3.2	Test Facility	11
3.3	Environmental conditions	11
3.4	Test Description	11
3.5	Equipment Used during the Test	14
3.6	Measurement uncertainty	15
<b><u>4</u></b>	<b><u>TEST CONDITIONS AND RESULTS.....</u></b>	<b><u>16</u></b>
4.1	Output Power	16
4.2	Peak-to-Average Ratio (PAR)	26
4.3	Occupied Bandwidth and Emission Bandwidth	27
4.4	Band Edge compliance	28
1.1	Spurious Emission on Antenna Port	31
4.5	Radiated Spurious Emission	34
4.6	Frequency Stability under Temperature & Voltage Variations	44
<b><u>5</u></b>	<b><u>TEST SETUP PHOTOS OF THE EUT.....</u></b>	<b><u>49</u></b>
<b><u>6</u></b>	<b><u>EXTERNAL PHOTOS OF THE EUT .....</u></b>	<b><u>49</u></b>
<b><u>7</u></b>	<b><u>INTERNAL PHOTOS OF THE EUT.....</u></b>	<b><u>49</u></b>

# **1 TEST STANDARDS**

The tests were performed according to following standards:

[FCC Part 22H](#): Cellular Radiotelephone Service

[FCC Part 24E](#): Broadband PCS

[FCC Part 27](#): MISCELLANEOUS WIRELESS COMMUNICATIONS SERVICES

[TIA-603-E March 2016](#): Land Mobile FM or PM Communications Equipment Measurement and Performance Standards.

[47 CFR FCC Part 15 Subpart B](#): Unintentional Radiators

[FCC Part 2](#): FREQUENCY ALLOCATIONS AND RADIO TREATY MATTERS; GENERAL RULES AND REGULATIONS

[ANSI C63.4:2014](#): Methods of Measurement of Radio-Noise Emissions from Low-Voltage Electrical and Electronic Equipment in the Range of 9 kHz to 40 GHz

[FCC KDB971168 D01](#) Power Meas License Digital Systems v03r01

## 2 SUMMARY

### 2.1 General Remarks

Date of receipt of test sample	:	December 29, 2020
Testing commenced on	:	December 29, 2020 ~ January 27, 2021
Date of Report	:	January 28, 2021

### 2.2 Product Description

The **Shanghai Armour Technology Co., Ltd.**'s Model: TB8 or the "EUT" as referred to in this report; more general information as follows, for more details, refer to the user's manual of the EUT.

EUT : TABLET

Test Model : TB8

Power Supply : DC 3.8V by Rechargeable Li-ion Battery, 9000mAh  
For Adapter Input: AC 100-240V, 50/60Hz, 0.35A Max  
Adapter Output: DC 5.0V, 2A

Hardware Version : HW\_V1.0

Software Version : Android10\_TB8\_V1\_0

#### Bluetooth

Frequency Range : 2402MHz ~ 2480MHz

Bluetooth Version : V4.0

Channel Number : 79 channels for Bluetooth V4.0(BDR/EDR)  
40 channels for Bluetooth V4.0(BT LE)

Channel Spacing : 1MHz for Bluetooth V4.0(BDR/EDR)  
2MHz for Bluetooth V4.0(BT LE)

Modulation Type : GFSK,  $\pi/4$ -DQPSK, 8-DPSK for Bluetooth V4.0(BDR/EDR)  
GFSK for Bluetooth V4.0(BT LE)

Antenna Description : Internal Antenna, 1.5dBi(Max.)

#### WIFI(2.4G Band)

Frequency Range : 2412MHz ~ 2462MHz

Channel Spacing : 5MHz

Channel Number : 11 Channels for 20MHz bandwidth (2412~2462MHz)  
7 Channels for 40MHz bandwidth (2422~2452MHz)

Modulation Type : IEEE 802.11b: DSSS (CCK, DQPSK, DBPSK)  
IEEE 802.11g: OFDM (64QAM, 16QAM, QPSK, BPSK)  
IEEE 802.11n: OFDM (64QAM, 16QAM, QPSK, BPSK)

Antenna Description : Internal Antenna, 1.5dBi(Max.)

#### 5.2G WLAN

Frequency Range : 5180MHz-5240MHz

Channel Number : 4 channels for 20MHz bandwidth(5180MHz-5240MHz)  
2 channels for 40MHz bandwidth(5190MHz~5230MHz)  
1 channels for 80MHz bandwidth(5210MHz)

Modulation Type : IEEE 802.11a/n20/n40/ac20/ac40/ac80: OFDM (64QAM, 16QAM, QPSK, BPSK)

Antenna Description : Internal Antenna, 1.5dBi(Max.)

**5.8G WLAN**

Frequency Range : 5745MHz-5825MHz  
 Channel Number : 5 channels for 20MHz bandwidth(5745MHz-5825MHz)  
 2 channels for 40MHz bandwidth(5755MHz~5795MHz)  
 1 channels for 80MHz bandwidth(5775MHz)  
 Modulation Type : IEEE 802.11a/n20/ac20/n40/ac40/ac80: OFDM (64QAM,  
 16QAM, QPSK, BPSK)  
 Antenna Description : Internal Antenna, 1.5dBi(Max.)

**2G**

Support Band :  GSM 900 (EU-Band)  DCS 1800 (EU-Band)  
 GSM 850 (U.S.-Band)  PCS 1900 (U.S.-Band)  
 Release Version : R99  
 GPRS Class : Class 12  
 EGPRS Class : Class 12  
 Type Of Modulation : GMSK for GSM/GPRS; 8PSK for EGPRS  
 Antenna Description : Internal Antenna  
 1.5dBi (max.) For GSM 850  
 1.5dBi (max.) For PCS 1900

**3G**

Support Band :  WCDMA Band II (U.S.-Band)  
 WCDMA Band V (U.S.-Band)  
 WCDMA Band IV (U.S.-Band)  
 WCDMA Band I (EU-Band)  
 WCDMA Band VIII (EU-Band)  
 Release Version : R6  
 Type Of Modulation : WCDMA: QPSK; HSDPA/HSUPA: QPSK  
 Antenna Description : Internal Antenna  
 1.5dBi (max.) For WCDMA Band II  
 1.5dBi (max.) For WCDMA Band V

**LTE**

Support Band :  E-UTRA Band 2(U.S.-Band)  
 E-UTRA Band 4(U.S.-Band)  
 E-UTRA Band 5(U.S.-Band)  
 E-UTRA Band 17(U.S.-Band)  
 E-UTRA Band 39(Non U.S.-Band)  
 E-UTRA Band 41(U.S.-Band)  
 LTE Release Version : R9  
 Type Of Modulation : QPSK/16QAM  
 Antenna Description : Internal Antenna  
 1.5dBi (max.) For E-UTRA Band 2  
 1.5dBi (max.) For E-UTRA Band 4  
 1.5dBi (max.) For E-UTRA Band 5  
 1.5dBi (max.) For E-UTRA Band 17  
 1.5dBi (max.) For E-UTRA Band 41  
 Power Class : Class 3  
 GPS function : Support and only RX

NFC :

Operating Frequency: : 13.56MHz;

Modulation Type : ASK

Antenna Description : Internal Antenna, 1.5dBi (Max.)

Extreme temp. Tolerance : -30°C to +50°C

Extreme vol. Limits : 3.6VDC to 4.35VDC (nominal: 3.8VDC)



## 2.3 Equipment under Test

### Power supply system utilised

Power supply voltage	:	<input type="radio"/> 120V/ 60 Hz	<input type="radio"/> 115V/60Hz
		<input type="radio"/> 12 V DC	<input type="radio"/> 24 V DC
		<input checked="" type="radio"/> Other (specified in blank below) 3.8 V DC	

## 2.4 Short description of the Equipment under Test (EUT)

### 2.4.1 GeneralDescription

TABLET is subscriber equipment in the BT / BLE / 2.4WIFI / 5.2WIFI / 5.8WIFI / NFC / GSM / WCDMA / LTE system. LTE frequency bands are band 2/4/5/7/17.

## 2.5 Internal Identification of AE used during the test

AE ID*	Description
AE1	Rechargeable Li-Polymer Battery
AE2	Switching Adapter

AE2

Adapter Model: UC13US

For Adapter Input: AC 100-240V, 50/60Hz, 0.35A Max

Adapter Output: DC 5.0V, 2A

Normal Accessory setting

Fully charged battery was used during the test.

## 2.6 EUT configuration

The following peripheral devices and interface cables were connected during the measurement:

● - supplied by the manufacturer

○ - supplied by the lab

<input type="radio"/>	Power Cable	Length (m) :	/
		Shield :	/
		Detachable :	/
<input type="radio"/>	Multimeter	Manufacturer :	/
		Model No. :	/

## 2.7 Related Submittal(s) / Grant (s)

This submittal(s) (test report) is intended for **FCC ID: 2AYKD-TB8** filing to comply with FCC Part 22, Part 24 and Part 27 Rules

## 2.8 Modifications

No modifications were implemented to meet testing criteria.

## 2.9 General Test Conditions/Configurations

### 2.10.1 Test Environment

EnvironmentParameter	SelectedValuesDuringTests	
Relative Humidity	Ambient	
Temperature	TN	Ambient
Voltage	VL	DC 3.6V
	VN	DC 3.8V
	VH	DC 4.35V

NOTE:VL=lower extreme testvoltage VN=nominal voltage  
VH=upper extreme testvoltage TN=normal temperature

### 3 TEST ENVIRONMENT

#### 3.1 Address of the test laboratory

##### Shenzhen LCS Compliance Testing Laboratory Ltd

101, 201 Bldg A & 301 Bldg C, Juji Industrial Park Yabianxueziwei, Shajing Street, Baoan District, Shenzhen, 518000, China

The sites are constructed in conformance with the requirements of ANSI C63.4 (2014) and CISPR Publication 22.

#### 3.2 Test Facility

The test facility is recognized, certified, or accredited by the following organizations:

NVLAP Accreditation Code is 600167-0.

FCC Designation Number is CN5024.

CAB identifier is CN0071.

CNAS Registration Number is L4595.

#### 3.3 Environmental conditions

During the measurement the environmental conditions were within the listed ranges:

Temperature:	15-35 ° C
Humidity:	30-60 %
Atmospheric pressure:	950-1050mbar

#### 3.4 Test Description

##### Band 2 (1850-1910MHz pairedwith 1930-1990MHz)

Test Item	FCC Rule No.	Requirements	Verdict
Effective(Isotropic) Radiated Output Power	§2.1046, §24.232	EIRP ≤ 2W	PASS
Peak-Average Ratio	§2.1046, §24.232	FCC:Limit≤13dB	PASS
Modulation Characteristics	§2.1047	Digital modulation	N/A
Bandwidth	§2.1049	OBW: No limit. EBW: No limit.	PASS
Band Edges Compliance	§2.1051, §24.238	≤ -13dBm/1%*EBW, In 1MHz bands immediately outside and adjacent to the frequency block.	PASS
Spurious Emission at Antenna Terminals	§2.1051, §24.238	≤-13dBm/1MHz, from 9kHz to10 <sup>th</sup> harmonics but outside authorized Operating frequency ranges.	PASS
Field Strength of Spurious Radiation	§2.1053, §24.238	≤ -13dBm/1MHz.	PASS
Frequency Stability	§2.1055, §24.235	FCC: within authorized frequency block.	PASS

NOTE 1:For the verdict, the“N/A”denotes“not applicable”,the“N/T”de notes “not tested”.

**Band 4 (1710-1755MHz pairedwith 2110-2155MHz)**

Test Item	FCC RuleNo.	Requirements	Verdict
Effective(Isotropic) Radiated Power Output Data	§2.1046, §27.50(d)	EIRP $\leq$ 1W;	PASS
Peak-Average Ratio	§2.1046, §27.50(d)	Limit $\leq$ 13dB	Pass
Modulation Characteristics	§2.1047	Digitalmodulation	N/A
Bandwidth	§2.1049	OBW: Nolimit. EBW: Nolimit.	PASS
BandEdges Compliance	§2.1051, §27.53(h)	$\leq$ -13dBm/1%*EBW,in1 MHz bands immediately outside and adjacent to the frequency block.	PASS
Spurious Emission at Antenna Terminals	§2.1051, §27.53(h)	$\leq$ -13dBm/1MHz, from 9kHz to 10 <sup>th</sup> harmonics but outside authorized operating frequency ranges.	PASS
Frequency Stability	§2.1055, §27.54	Within authorized bands of operation/frequency block.	PASS
Radiated spurious emission	§2.1053, §27.53(h)	$\leq$ -13dBm/1MHz.	PASS

NOTE 1: For the verdict, the "N/A" denotes "not applicable", the "N/T" de notes "not tested"

**Band 5 (824-849MHz pairedwith 869-894MHz)**

Test Item	FCC Rule No.	Requirements	Verdict
Effective(Isotropic) Radiated Output Power	§2.1046, §22.913	FCC: ERP $\leq$ 7W.	Pass
Modulation Characteristics	§2.1047	Digital modulation	N/A
Bandwidth	§2.1049	OBW: No limit. EBW: No limit.	Pass
Band Edges Compliance	§2.1051, §22.917	$\leq$ -13dBm/1%*EBW, In 1MHz bands immediately outside and adjacent to The frequency block.	Pass
Spurious Emission at Antenna Terminals	§2.1051, §22.917	FCC: $\leq$ -13dBm/100kHz, from 9kHz to 10th harmonics but outside authorized operating frequency ranges.	Pass
Field Strength of Spurious Radiation	§2.1053, §22.917	FCC: $\leq$ -13dBm/100kHz.	Pass
Frequency Stability	§2.1055, §22.355	$\leq$ $\pm$ 2.5ppm.	Pass

NOTE 1:For the verdict, the"N/A"denotes"not applicable",the"N/T"de notes "not tested".

**Band 17(704-716MHz pairedwith 734-746MHz)**

Test Item	FCC Rule No.	Requirements	Verdict
Effective(Isotropic) Radiated Power Output Data	§2.1046, §27.50(b)	ERP ≤ 3W;	PASS
Peak-Average Ratio	§2.1046, §27.50(b)	Limit≤13dB	PASS
Modulation Characteristics	§2.1047	Digitalmodulation	N/A
Bandwidth	§2.1049	OBW: Nolimit. EBW: Nolimit.	PASS
BandEdges Compliance	§2.1051, §27.53(c)	≤ -13dBm/1%*EBW, in1 MHz bands immediately outside and adjacent to The frequency block.	PASS
Spurious Emission at Antenna Terminals	§2.1051, §27.53(c)	≤ -13dBm/100KHz, from 9kHz to10th harmonics but outside authorized Operating frequency ranges.	PASS
Frequency Stability	§2.1055, §27.54	Within authorized bands of operation/frequency block.	PASS
Radiated spurious emission	§2.1053, §27.53(c)	≤ -13dBm/100KHz.	PASS

NOTE 1:For the verdict, the“N/A”denotes“not applicable”,the“N/T”de notes “not tested”.

**TDD Band 41(2555-2655MHz)**

Test Item	FCC Rule No.	Requirements	Verdict
Effective(Isotropic) Radiated Power Output Data	§2.1046, §27.50(h)	ERP ≤ 2W;	PASS
Peak-Average Ratio	§2.1046, §27.50	Limit≤13dB	PASS
Modulation Characteristics	§2.1047	Digitalmodulation	N/A
Bandwidth	§2.1049	OBW: Nolimit. EBW: Nolimit.	PASS
BandEdges Compliance	§2.1051, §27.53(m)	≤ -13dBm/1%*EBW, in1 MHz bands immediately outside and adjacent to The frequency block.	PASS
Spurious Emission at Antenna Terminals	§2.1051, §27.53(m)	≤ -13dBm/1MHz, from 9kHz to10th harmonics but outside authorized Operating frequency ranges.	PASS
Frequency Stability	§2.1055, §27.54	Within authorized bands of operation/frequency block.	PASS
Radiated spurious emission	§2.1053, §27.53(m)	≤ -25dBm/1MHz.	PASS

NOTE 1:For the verdict, the“N/A”denotes“not applicable”,the“N/T”de notes “not tested”.

### 3.5 Equipment Used during the Test

Item	Equipment	Manufacturer	Model No.	Serial No.	Cal Date	Due Date
1	LTE Test Software	Tonscend	JS1120-1	N/A	N/A	N/A
2	RF Control Unit	Tonscend	JS0806	158060009	2020-06-22	2021-06-21
3	MXA Signal Analyzer	Agilent	N9020A	MY51250905	2020-11-21	2021-11-20
4	DC Power Supply	Agilent	E3642A	N/A	2020-11-13	2021-11-12
5	MXG Vector Signal Generator	Agilent	N5182A	MY47071151	2020-06-22	2021-06-21
6	PSG Analog Signal Generator	Agilent	E8257D	MY4520521	2020-06-22	2021-06-21
7	Temperature & Humidity Chamber	GUANGZHOU GOGNWEN	GDS-100	70932	2020-10-08	2021-10-07
8	EMI Test Software	AUDIX	E3	/	N/A	N/A
9	3m Semi Anechoic Chamber	SIDT FRANKONIA	SAC-3M	03CH03-HY	2020-06-22	2021-06-21
10	Positioning Controller	MF	MF7082	MF78020803	2020-06-22	2021-06-21
11	Active Loop Antenna	SCHWARZBECK	FMZB 1519B	00005	2018-07-26	2021-07-25
12	By-log Antenna	SCHWARZBECK	VULB9163	9163-470	2018-07-26	2021-07-25
13	Horn Antenna	SCHWARZBECK	BBHA 9120D	9120D-1925	2018-07-02	2021-07-01
14	Broadband Horn Antenna	SCHWARZBECK	BBHA 9170	791	2020-09-20	2023-09-19
15	Broadband Preamplifier	SCHWARZBECK	BBV9745	9719-025	2020-06-22	2021-06-21
16	EMI Test Receiver	R&S	ESR 7	101181	2020-06-22	2021-06-21
17	RS SPECTRUM ANALYZER	R&S	FSP40	100503	2020-11-21	2021-11-20
18	Broadband Preamplifier	/	BP-01M18G	P190501	2020-06-22	2021-06-21
19	RF Cable-R03m	Jye Bao	RG142	CB021	2020-06-22	2021-06-21
20	RF Cable-HIGH	SUHNER	SUCOFLEX 106	03CH03-HY	2020-06-22	2021-06-21
21	WIDEBAND RADIO COMMUNICATION TESTER	R&S	CMW 500	103818	2020-06-22	2021-06-21
22	RF Filter	Micro-Tronics	BRC50718	S/N-017	2020-11-21	2021-11-20
23	RF Filter	Micro-Tronics	BRC50719	S/N-011	2020-11-21	2021-11-20
24	RF Filter	Micro-Tronics	BRC50720	S/N-011	2020-11-21	2021-11-20
25	RF Filter	Micro-Tronics	BRC50721	S/N-013	2020-11-21	2021-11-20
26	RF Filter	Micro-Tronics	BRM50702	S/N-195	2020-06-22	2021-06-21
27	6dB Attenuator	/	100W/6dB	1172040	2020-06-22	2021-06-21
28	3dB Attenuator	/	2N-3dB	/	2020-06-22	2021-06-21
29	RS SPECTRUM ANALYZER	R&S	FSP40	100503	2020-11-21	2021-11-20

### 3.6 Measurement uncertainty

The data and results referenced in this document are true and accurate. The reader is cautioned that there may be errors within the calibration limits of the equipment and facilities. The measurement uncertainty was calculated for all measurements listed in this test report acc. to ETSI TR 100 028 "Electromagnetic compatibility and Radio spectrum Matters (ERM); Uncertainties in the measurement of mobile radio equipment characteristics" and is documented in the Shenzhen LCS Compliance Testing Laboratory Ltd. quality system acc. to DIN EN ISO/IEC 17025. Furthermore, component and process variability of devices similar to that tested may result in additional deviation. The manufacturer has the sole responsibility of continued compliance of the device.

Hereafter the best measurement capability for Shenzhen LCS Compliance Testing Laboratory Ltd. is reported:

Test	Range	Measurement Uncertainty	Notes
Radiated Emission	30~1000MHz	3.10 dB	(1)
Radiated Emission	1~18GHz	3.80 dB	(1)
Radiated Emission	18-40GHz	3.90 dB	(1)
Conducted Disturbance	0.15~30MHz	1.63 dB	(1)
Conducted Power	9KHz~18GHz	0.61 dB	(1)
Spurious RF Conducted Emission	9KHz~40GHz	1.22 dB	(1)
Band Edge Compliance of RF Emission	9KHz~40GHz	1.22 dB	(1)
Occupied Bandwidth	9KHz~40GHz	-	(1)

(1) This uncertainty represents an expanded uncertainty expressed at approximately the 95% confidence level using a coverage factor of  $k=1.96$ .

## 4 TEST CONDITIONS AND RESULTS

### 4.1 Output Power

#### TEST APPLICABLE

During the process of testing, the EUT was controlled via R&S Digital Radio Communication tester (CMW 500) to ensure max power transmission and proper modulation. This result contains output power and EIRP measurements for the EUT. In all cases, output power is within the specified limits.

#### 4.1.1. Conducted Output Power

##### TEST CONFIGURATION

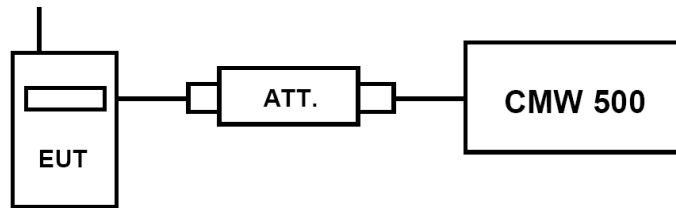

##### TEST PROCEDURE

###### **Conducted Power Measurement:**

- Place the EUT on a bench and set it in transmitting mode.
- Connect a low loss RF cable from the antenna port to a CMW 500 by an Att.
- EUT Communicate with CMW 500 then selects a channel for testing.
- Add a correction factor to the display CMW 500, and then test.

##### TEST RESULTS

###### *Remark:*

- We were tested all RB Configuration refer 3GPP TS136 521 for each Channel Bandwidth of LTE FDD Band 2, LTE FDD Band 4, LTE FDD Band 5, LTE FDD Band 17, LTE FDD Band 41; recorded worst case for each Channel Bandwidth of LTE FDD Band 2, LTE FDD Band 4, LTE FDD Band 5, LTE FDD Band 17 and LTE FDD Band 41.
- For E-UTRA Band 2, please refer to Appendix F: Appendix F.1
- For E-UTRA Band 4, please refer to Appendix G: Section G.1
- For E-UTRA Band 5, please refer to Appendix H: Section H.1
- For E-UTRA Band 17, please refer to Appendix I: Section I.1
- For E-UTRA Band 41, please refer to Appendix J: Section J.1



## 4.1.2. Radiated Output Power

### LIMIT

This is the test for the maximum radiated power from the EUT.

Per §22.913(2) Extend coverage on a secondary basis into cellular unserved areas, as those areas are defined in §22.949, the ERP of base transmitters and cellular repeaters of such systems must not exceed 1000 Watts. The ERP of mobile transmitters and auxiliary test transmitters must not exceed 7 Watts.

Rule Part 24.232(c) specifies, "Mobile/portable stations are limited to 2 watts e.i.r.p. Peak power" and 24.232(e) specifies that "Peak transmit power must be measured over any interval of continuous transmission using instrumentation calibrated in terms of an rms-equivalent voltage." .

Per Part 27.50(d) (4) specifies, Fixed, mobile, and portable (hand-held) stations operating in the 1710-1755MHz band are limited to 1W EIRP. Fixed stations operating in this band are limited to a maximum antenna height of 10 meters above ground. Mobile and portable stations operating in this band must employ a means for limiting power to the minimum necessary for successful communications.

Per Part 27.50(c) (10) specifies, Portable stations (hand-held devices) in the 600 MHz uplink band and the 698-746 MHz band, and fixed and mobile stations in the 600 MHz uplink band are limited to 3 watts ERP.

Per Part 27.50(h) (2) specifies Mobile and other user stations. Mobile stations are limited to 2.0 watts EIRP. All user stations are limited to 2.0 watts transmitter output power.

### TEST CONFIGURATION

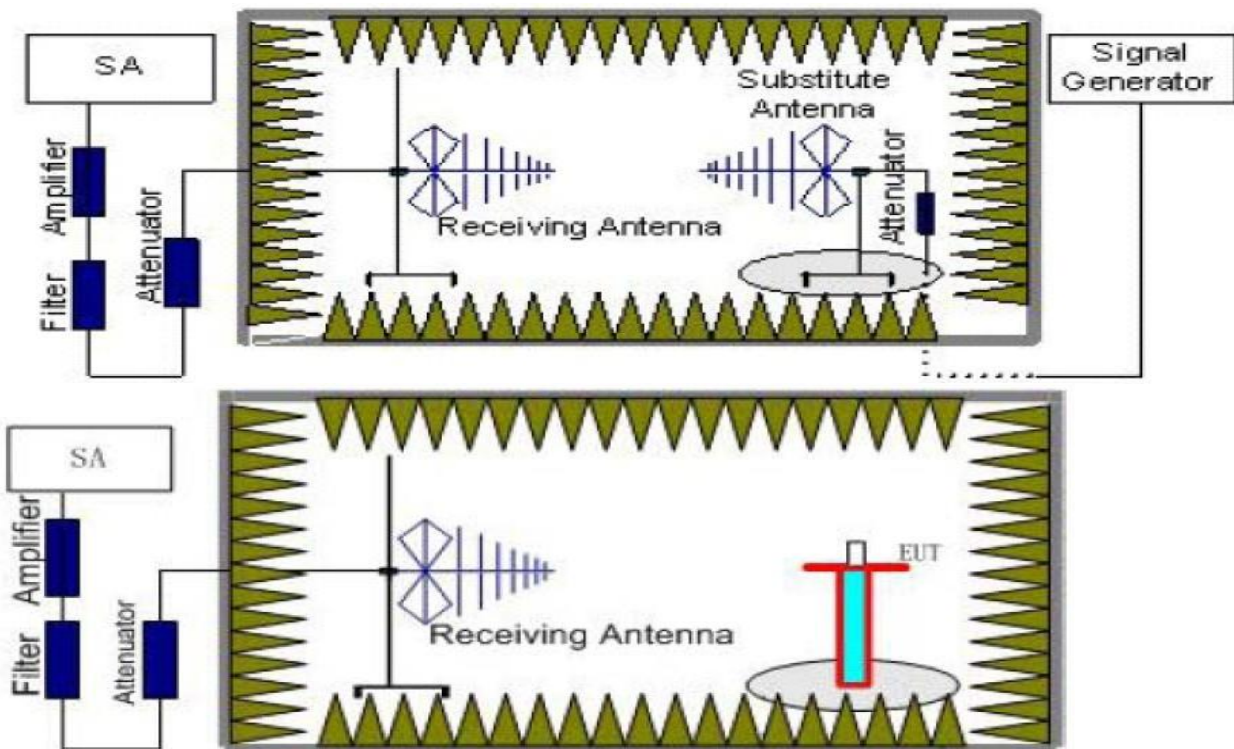

### TEST PROCEDURE

1. EUT was placed on a 1.50 meter high non-conductive stand at a 3 meter test distance from the receive antenna. A receiving antenna was placed on the antenna mast 3 meters from the EUT for emission measurements. The height of receiving antenna is 1.50m. Detected emissions were maximized at each frequency by rotating the EUT through 360° and adjusting the receiving antenna polarization. The radiated emission measurements of all transmit frequencies in three channels (High, Middle, Low) were measured with peak detector.
2. A log-periodic antenna or double-ridged waveguide horn antenna shall be substituted in place of the EUT. The log-periodic antenna will be driven by a signal generator and the level will be adjusted till the same power value on the spectrum analyzer or receiver. The level of the spurious emissions can be calculated through the level of the signal generator, cable loss, the gain of the substitution antenna and the reading of the spectrum analyzer or receiver.

3. The EUT is then put into continuously transmitting mode at its maximum power level during the test. Set Test Receiver or Spectrum RBW=1MHz, VBW=3MHz, And the maximum value of the receiver should be recorded as ( $P_r$ ).
4. The EUT shall be replaced by a substitution antenna. In the chamber, a substitution antenna for the frequency band of interest is placed at the reference point of the chamber. An RF Signal source for the frequency band of interest is connected to the substitution antenna with a cable that has been constructed to not interfere with the radiation pattern of the antenna. A power ( $P_{Mea}$ ) is applied to the input of the substitution antenna, and adjust the level of the signal generator output until the value of the receiver reach the previously recorded ( $P_r$ ). The power of signal source ( $P_{Mea}$ ) is recorded. The test should be performed by rotating the test item and adjusting the receiving antenna polarization.
5. A amplifier should be connected to the Signal Source output port. And the cable should be connect between the Amplifier and the Substitution Antenna. The cable loss ( $P_{cl}$ ), the Substitution Antenna Gain ( $G_a$ ) and the Amplifier Gain ( $P_{Ag}$ ) should be recorded after test.  
The measurement results are obtained as described below:  
 $Power(EIRP) = P_{Mea} + P_{Ag} - P_{cl} + G_a$
6. This value is EIRP since the measurement is calibrated using an antenna of known gain (2.15 dBi) and known input power.
7. ERP can be calculated from EIRP by subtracting the gain of the dipole,  $ERP = EIRP - 2.15dBi$ .

## TEST RESULTS

### Radiated Measurement:

#### Remark:

1. We were tested all RB Configuration refer 3GPP TS136 521 for each Channel Bandwidth of LTE FDD Band 2, LTE FDD Band 4, LTE FDD Band 5, LTE FDD Band 17, LTE FDD Band 41; recorded worst case for each Channel Bandwidth of LTE FDD Band 2, LTE FDD Band 4, LTE FDD Band 5, LTE FDD Band 17 and LTE FDD Band 41.
2.  $EIRP = P_{Mea}(dBm) - P_{cl}(dB) + P_{Ag}(dB) + G_a(dBi)$
3.  $ERP = EIRP - 2.15dBi$  as EIRP by subtracting the gain of the dipole.
4. Margin = Emission Level - Limit
5. We test the H direction and V direction recorded worst case

#### LTE FDD Band 2\_Channel Bandwidth 1.4MHz\_QPSK

Frequency (MHz)	$P_{Mea}$ (dBm)	$P_{cl}$ (dB)	$G_a$ Antenna Gain(dB)	$P_{Ag}$ (dB)	Burst Average EIRP (dBm)	Limit (dBm)	Margin (dB)	Polarization
1850.7	-19.47	4.03	8.38	35.51	20.39	33.01	-12.62	V
1880.0	-19.05	4.08	8.33	35.56	20.76	33.01	-12.25	V
1909.3	-19.53	4.14	8.26	35.63	20.22	33.01	-12.79	V

#### LTE FDD Band 2\_Channel Bandwidth 3MHz\_QPSK

Frequency (MHz)	$P_{Mea}$ (dBm)	$P_{cl}$ (dB)	$G_a$ Antenna Gain(dB)	$P_{Ag}$ (dB)	Burst Average EIRP (dBm)	Limit (dBm)	Margin (dB)	Polarization
1851.5	-19.86	4.03	8.38	35.51	20.00	33.01	-13.01	V
1880.0	-19.73	4.08	8.33	35.56	20.08	33.01	-12.93	V
1908.5	-19.55	4.14	8.26	35.63	20.20	33.01	-12.81	V

#### LTE FDD Band 2\_Channel Bandwidth 5MHz\_QPSK

Frequency (MHz)	$P_{Mea}$ (dBm)	$P_{cl}$ (dB)	$G_a$ Antenna Gain(dB)	$P_{Ag}$ (dB)	Burst Average EIRP (dBm)	Limit (dBm)	Margin (dB)	Polarization
1852.5	-20.71	4.03	8.38	35.51	19.15	33.01	-13.86	V
1880.0	-20.52	4.08	8.33	35.56	19.29	33.01	-13.72	V
1907.5	-20.86	4.14	8.26	35.63	18.89	33.01	-14.12	V

**LTE FDD Band 2\_Channel Bandwidth 10MHz\_QPSK**

Frequency (MHz)	P <sub>Mea</sub> (dBm)	P <sub>cl</sub> (dB)	G <sub>a</sub> Antenna Gain(dB)	P <sub>Aq</sub> (dB)	Burst Average EIRP (dBm)	Limit (dBm)	Margin (dB)	Polarization
1855.0	-20.60	4.03	8.38	35.51	19.26	33.01	-13.75	V
1880.0	-20.58	4.08	8.33	35.56	19.23	33.01	-13.78	V
1905.0	-20.92	4.14	8.26	35.63	18.83	33.01	-14.18	V

**LTE FDD Band 2\_Channel Bandwidth 15MHz\_QPSK**

Frequency (MHz)	P <sub>Mea</sub> (dBm)	P <sub>cl</sub> (dB)	G <sub>a</sub> Antenna Gain(dB)	P <sub>Aq</sub> (dB)	Burst Average EIRP (dBm)	Limit (dBm)	Margin (dB)	Polarization
1857.5	-21.65	4.03	8.38	35.51	18.21	33.01	-14.80	V
1880.0	-21.71	4.08	8.33	35.56	18.10	33.01	-14.91	V
1902.5	-21.50	4.14	8.26	35.63	18.25	33.01	-14.76	V

**LTE FDD Band 2\_Channel Bandwidth 20MHz\_QPSK**

Frequency (MHz)	P <sub>Mea</sub> (dBm)	P <sub>cl</sub> (dB)	G <sub>a</sub> Antenna Gain(dB)	P <sub>Aq</sub> (dB)	Burst Average EIRP (dBm)	Limit (dBm)	Margin (dB)	Polarization
1860.0	-22.19	4.03	8.38	35.51	17.67	33.01	-15.34	V
1880.0	-22.44	4.08	8.33	35.56	17.37	33.01	-15.64	V
1900.0	-22.43	4.14	8.26	35.63	17.32	33.01	-15.69	V

**LTE FDD Band 2\_Channel Bandwidth 1.4MHz\_16QAM**

Frequency (MHz)	P <sub>Mea</sub> (dBm)	P <sub>cl</sub> (dB)	G <sub>a</sub> Antenna Gain(dB)	P <sub>Aq</sub> (dB)	Burst Average EIRP (dBm)	Limit (dBm)	Margin (dB)	Polarization
1850.7	-20.02	4.03	8.38	35.51	19.84	33.01	-13.17	V
1880.0	-20.05	4.08	8.33	35.56	19.76	33.01	-13.25	V
1909.3	-20.19	4.14	8.26	35.63	19.56	33.01	-13.45	V

**LTE FDD Band 2\_Channel Bandwidth 3MHz\_16QAM**

Frequency (MHz)	P <sub>Mea</sub> (dBm)	P <sub>cl</sub> (dB)	G <sub>a</sub> Antenna Gain(dB)	P <sub>Aq</sub> (dB)	Burst Average EIRP (dBm)	Limit (dBm)	Margin (dB)	Polarization
1851.5	-20.44	4.03	8.38	35.51	19.42	33.01	-13.59	V
1880.0	-20.41	4.08	8.33	35.56	19.40	33.01	-13.61	V
1908.5	-20.18	4.14	8.26	35.63	19.57	33.01	-13.44	V

**LTE FDD Band 2\_Channel Bandwidth 5MHz\_16QAM**

Frequency (MHz)	P <sub>Mea</sub> (dBm)	P <sub>cl</sub> (dB)	G <sub>a</sub> Antenna Gain(dB)	P <sub>Aq</sub> (dB)	Burst Average EIRP (dBm)	Limit (dBm)	Margin (dB)	Polarization
1852.5	-21.01	4.03	8.38	35.51	18.85	33.01	-14.16	V
1880.0	-21.23	4.08	8.33	35.56	18.58	33.01	-14.43	V
1907.5	-20.81	4.14	8.26	35.63	18.94	33.01	-14.07	V

**LTE FDD Band 2\_Channel Bandwidth 10MHz\_16QAM**

Frequency (MHz)	P <sub>Mea</sub> (dBm)	P <sub>cl</sub> (dB)	G <sub>a</sub> Antenna Gain(dB)	P <sub>Aa</sub> (dB)	Burst Average EIRP (dBm)	Limit (dBm)	Margin (dB)	Polarization
1855.0	-21.08	4.03	8.38	35.51	18.78	33.01	-14.23	V
1880.0	-21.65	4.08	8.33	35.56	18.16	33.01	-14.85	V
1905.0	-21.19	4.14	8.26	35.63	18.56	33.01	-14.45	V

**LTE FDD Band 2\_Channel Bandwidth 15MHz\_16QAM**

Frequency (MHz)	P <sub>Mea</sub> (dBm)	P <sub>cl</sub> (dB)	G <sub>a</sub> Antenna Gain(dB)	P <sub>Aa</sub> (dB)	Burst Average EIRP (dBm)	Limit (dBm)	Margin (dB)	Polarization
1857.5	-22.00	4.03	8.38	35.51	17.86	33.01	-15.15	V
1880.0	-21.84	4.08	8.33	35.56	17.97	33.01	-15.04	V
1902.5	-22.03	4.14	8.26	35.63	17.72	33.01	-15.29	V

**LTE FDD Band 2\_Channel Bandwidth 20MHz\_16QAM**

Frequency (MHz)	P <sub>Mea</sub> (dBm)	P <sub>cl</sub> (dB)	G <sub>a</sub> Antenna Gain(dB)	P <sub>Aa</sub> (dB)	Burst Average EIRP (dBm)	Limit (dBm)	Margin (dB)	Polarization
1860.0	-22.03	4.03	8.38	35.51	17.83	33.01	-15.18	V
1880.0	-22.80	4.08	8.33	35.56	17.01	33.01	-16.00	V
1900.0	-22.72	4.14	8.26	35.63	17.03	33.01	-15.98	V

**LTE FDD Band 4\_Channel Bandwidth 1.4MHz\_QPSK**

Frequency (MHz)	P <sub>Mea</sub> (dBm)	P <sub>cl</sub> (dB)	G <sub>a</sub> Antenna Gain(dB)	P <sub>Aa</sub> (dB)	Burst Average EIRP (dBm)	Limit (dBm)	Margin (dB)	Polarization
1710.7	-18.62	3.93	9.05	34.96	21.46	30.00	-8.54	V
1732.5	-19.06	3.93	8.89	35.01	20.91	30.00	-9.09	V
1754.3	-19.10	3.94	8.76	35.08	20.80	30.00	-9.20	V

**LTE FDD Band 4\_Channel Bandwidth 3MHz\_QPSK**

Frequency (MHz)	P <sub>Mea</sub> (dBm)	P <sub>cl</sub> (dB)	G <sub>a</sub> Antenna Gain(dB)	P <sub>Aa</sub> (dB)	Burst Average EIRP (dBm)	Limit (dBm)	Margin (dB)	Polarization
1711.5	-19.51	3.93	9.05	34.96	20.57	30.00	-9.43	V
1732.5	-18.90	3.93	8.89	35.01	21.07	30.00	-8.93	V
1753.5	-19.41	3.94	8.76	35.08	20.49	30.00	-9.51	V

**LTE FDD Band 4\_Channel Bandwidth 5MHz\_QPSK**

Frequency (MHz)	P <sub>Mea</sub> (dBm)	P <sub>cl</sub> (dB)	G <sub>a</sub> Antenna Gain(dB)	P <sub>Aa</sub> (dB)	Burst Average EIRP (dBm)	Limit (dBm)	Margin (dB)	Polarization
1712.5	-18.74	3.93	9.05	34.96	21.34	30.00	-8.66	V
1732.5	-19.26	3.93	8.89	35.01	20.71	30.00	-9.29	V
1752.5	-18.83	3.94	8.76	35.08	21.07	30.00	-8.93	V

**LTE FDD Band 4\_Channel Bandwidth 10MHz\_QPSK**

Frequency (MHz)	P <sub>Mea</sub> (dBm)	P <sub>cl</sub> (dB)	G <sub>a</sub> Antenna Gain(dB)	P <sub>Aq</sub> (dB)	Burst Average EIRP (dBm)	Limit (dBm)	Margin (dB)	Polarization
1715.0	-19.71	3.93	9.05	34.96	20.37	30.00	-9.63	V
1732.5	-19.29	3.93	8.89	35.01	20.68	30.00	-9.32	V
1750.0	-19.14	3.94	8.76	35.08	20.76	30.00	-9.24	V

**LTE FDD Band 4\_Channel Bandwidth 15MHz\_QPSK**

Frequency (MHz)	P <sub>Mea</sub> (dBm)	P <sub>cl</sub> (dB)	G <sub>a</sub> Antenna Gain(dB)	P <sub>Aq</sub> (dB)	Burst Average EIRP (dBm)	Limit (dBm)	Margin (dB)	Polarization
1717.5	-19.29	3.93	9.05	34.96	20.79	30.00	-9.21	V
1732.5	-18.83	3.93	8.89	35.01	21.14	30.00	-8.86	V
1747.5	-19.43	3.94	8.76	35.08	20.47	30.00	-9.53	V

**LTE FDD Band 4\_Channel Bandwidth 20MHz\_QPSK**

Frequency (MHz)	P <sub>Mea</sub> (dBm)	P <sub>cl</sub> (dB)	G <sub>a</sub> Antenna Gain(dB)	P <sub>Aq</sub> (dB)	Burst Average EIRP (dBm)	Limit (dBm)	Margin (dB)	Polarization
1720.0	-19.55	3.93	9.05	34.96	20.53	30.00	-9.47	V
1732.5	-18.97	3.93	8.89	35.01	21.00	30.00	-9.00	V
1745.0	-19.09	3.94	8.76	35.08	20.81	30.00	-9.19	V

**LTE FDD Band 4\_Channel Bandwidth 1.4MHz\_16QAM**

Frequency (MHz)	P <sub>Mea</sub> (dBm)	P <sub>cl</sub> (dB)	G <sub>a</sub> Antenna Gain(dB)	P <sub>Aq</sub> (dB)	Burst Average EIRP (dBm)	Limit (dBm)	Margin (dB)	Polarization
1710.7	-19.49	3.93	9.05	34.96	20.59	30.00	-9.41	V
1732.5	-19.86	3.93	8.89	35.01	20.11	30.00	-9.89	V
1754.3	-18.97	3.94	8.76	35.08	20.93	30.00	-9.07	V

**LTE FDD Band 4\_Channel Bandwidth 3MHz\_16QAM**

Frequency (MHz)	P <sub>Mea</sub> (dBm)	P <sub>cl</sub> (dB)	G <sub>a</sub> Antenna Gain(dB)	P <sub>Aq</sub> (dB)	Burst Average EIRP (dBm)	Limit (dBm)	Margin (dB)	Polarization
1711.5	-18.64	3.93	9.05	34.96	21.44	30.00	-8.56	V
1732.5	-18.62	3.93	8.89	35.01	21.35	30.00	-8.65	V
1753.5	-19.41	3.94	8.76	35.08	20.49	30.00	-9.51	V

**LTE FDD Band 4\_Channel Bandwidth 5MHz\_16QAM**

Frequency (MHz)	P <sub>Mea</sub> (dBm)	P <sub>cl</sub> (dB)	G <sub>a</sub> Antenna Gain(dB)	P <sub>Aq</sub> (dB)	Burst Average EIRP (dBm)	Limit (dBm)	Margin (dB)	Polarization
1712.5	-19.01	3.93	9.05	34.96	21.07	30.00	-8.93	V
1732.5	-19.30	3.93	8.89	35.01	20.67	30.00	-9.33	V
1752.5	-18.93	3.94	8.76	35.08	20.97	30.00	-9.03	V

**LTE FDD Band 4\_Channel Bandwidth 10MHz\_16QAM**

Frequency (MHz)	P <sub>Mea</sub> (dBm)	P <sub>cl</sub> (dB)	G <sub>a</sub> Antenna Gain(dB)	P <sub>Aq</sub> (dB)	Burst Average EIRP (dBm)	Limit (dBm)	Margin (dB)	Polarization
1715.0	-18.73	3.93	9.05	34.96	21.35	30.00	-8.65	V
1732.5	-19.25	3.93	8.89	35.01	20.72	30.00	-9.28	V
1750.0	-19.46	3.94	8.76	35.08	20.44	30.00	-9.56	V

**LTE FDD Band 4\_Channel Bandwidth 15MHz\_16QAM**

Frequency (MHz)	P <sub>Mea</sub> (dBm)	P <sub>cl</sub> (dB)	G <sub>a</sub> Antenna Gain(dB)	P <sub>Aq</sub> (dB)	Burst Average EIRP (dBm)	Limit (dBm)	Margin (dB)	Polarization
1717.5	-19.67	3.93	9.05	34.96	20.41	30.00	-9.59	V
1732.5	-19.44	3.93	8.89	35.01	20.53	30.00	-9.47	V
1747.5	-18.90	3.94	8.76	35.08	21.00	30.00	-9.00	V

**LTE FDD Band 4\_Channel Bandwidth 20MHz\_16QAM**

Frequency (MHz)	P <sub>Mea</sub> (dBm)	P <sub>cl</sub> (dB)	G <sub>a</sub> Antenna Gain(dB)	P <sub>Aq</sub> (dB)	Burst Average EIRP (dBm)	Limit (dBm)	Margin (dB)	Polarization
1720.0	-19.26	3.93	9.05	34.96	20.82	30.00	-9.18	V
1732.5	-19.15	3.93	8.89	35.01	20.82	30.00	-9.18	V
1745.0	-18.84	3.94	8.76	35.08	21.06	30.00	-8.94	V

**LTE FDD Band 5\_Channel Bandwidth 1.4MHz\_QPSK**

Frequency (MHz)	P <sub>Mea</sub> (dBm)	P <sub>cl</sub> (dB)	G <sub>a</sub> Antenna Gain(dB)	Correction (dB)	P <sub>Aq</sub> (dB)	Peak ERP (dBm)	Limit (dBm)	Margin (dB)	Polarization
824.70	-16.03	3.45	8.45	2.15	33.79	20.61	38.45	-17.84	V
836.50	-16.00	3.49	8.45	2.15	33.85	20.66	38.45	-17.79	V
848.30	-16.01	3.55	8.36	2.15	33.88	20.53	38.45	-17.92	V

**LTE FDD Band 5\_Channel Bandwidth 3MHz\_QPSK**

Frequency (MHz)	P <sub>Mea</sub> (dBm)	P <sub>cl</sub> (dB)	G <sub>a</sub> Antenna Gain(dB)	Correction (dB)	P <sub>Aq</sub> (dB)	Peak ERP (dBm)	Limit (dBm)	Margin (dB)	Polarization
825.50	-15.69	3.45	8.45	2.15	33.79	20.95	38.45	-17.50	V
836.50	-16.07	3.49	8.45	2.15	33.85	20.59	38.45	-17.86	V
847.50	-15.72	3.55	8.36	2.15	33.88	20.82	38.45	-17.63	V

**LTE FDD Band 5\_Channel Bandwidth 5MHz\_QPSK**

Frequency (MHz)	P <sub>Mea</sub> (dBm)	P <sub>cl</sub> (dB)	G <sub>a</sub> Antenna Gain(dB)	Correction (dB)	P <sub>Aq</sub> (dB)	Peak ERP (dBm)	Limit (dBm)	Margin (dB)	Polarization
826.50	-16.32	3.45	8.45	2.15	33.79	20.32	38.45	-18.13	V
836.50	-16.14	3.49	8.45	2.15	33.85	20.52	38.45	-17.93	V
846.50	-16.00	3.55	8.36	2.15	33.88	20.54	38.45	-17.91	V

**LTE FDD Band 5\_Channel Bandwidth 10MHz\_QPSK**

Frequency (MHz)	P <sub>Mea</sub> (dBm)	P <sub>cl</sub> (dB)	G <sub>a</sub> Antenna Gain(dB)	Correction (dB)	P <sub>Aq</sub> (dB)	Peak ERP (dBm)	Limit (dBm)	Margin (dB)	Polarization
829.00	-16.46	3.45	8.45	2.15	33.79	20.18	38.45	-18.27	V
836.50	-16.36	3.49	8.45	2.15	33.85	20.30	38.45	-18.15	V
844.00	-16.48	3.55	8.36	2.15	33.88	20.06	38.45	-18.39	V

**LTE FDD Band 5\_Channel Bandwidth 1.4MHz\_16QAM**

Frequency (MHz)	P <sub>Mea</sub> (dBm)	P <sub>cl</sub> (dB)	G <sub>a</sub> Antenna Gain(dB)	Correction (dB)	P <sub>Aq</sub> (dB)	Peak ERP (dBm)	Limit (dBm)	Margin (dB)	Polarization
824.70	-17.48	3.45	8.45	2.15	33.79	19.16	38.45	-19.29	V
836.50	-16.84	3.49	8.45	2.15	33.85	19.82	38.45	-18.63	V
848.30	-16.90	3.55	8.36	2.15	33.88	19.64	38.45	-18.81	V

**LTE FDD Band 5\_Channel Bandwidth 3MHz\_16QAM**

Frequency (MHz)	P <sub>Mea</sub> (dBm)	P <sub>cl</sub> (dB)	G <sub>a</sub> Antenna Gain(dB)	Correction (dB)	P <sub>Aq</sub> (dB)	Peak ERP (dBm)	Limit (dBm)	Margin (dB)	Polarization
825.50	-16.74	3.45	8.45	2.15	33.79	19.90	38.45	-18.55	V
836.50	-17.38	3.49	8.45	2.15	33.85	19.28	38.45	-19.17	V
847.50	-17.10	3.55	8.36	2.15	33.88	19.44	38.45	-19.01	V

**LTE FDD Band 5\_Channel Bandwidth 5MHz\_16QAM**

Frequency (MHz)	P <sub>Mea</sub> (dBm)	P <sub>cl</sub> (dB)	G <sub>a</sub> Antenna Gain(dB)	Correction (dB)	P <sub>Aq</sub> (dB)	Peak ERP (dBm)	Limit (dBm)	Margin (dB)	Polarization
826.50	-16.97	3.45	8.45	2.15	33.79	19.67	38.45	-18.78	V
836.50	-17.27	3.49	8.45	2.15	33.85	19.39	38.45	-19.06	V
846.50	-17.33	3.55	8.36	2.15	33.88	19.21	38.45	-19.24	V

**LTE FDD Band 5\_Channel Bandwidth 10MHz\_16QAM**

Frequency (MHz)	P <sub>Mea</sub> (dBm)	P <sub>cl</sub> (dB)	G <sub>a</sub> Antenna Gain(dB)	Correction (dB)	P <sub>Aq</sub> (dB)	Peak ERP (dBm)	Limit (dBm)	Margin (dB)	Polarization
829.00	-16.53	3.45	8.45	2.15	33.79	20.11	38.45	-18.34	V
836.50	-17.34	3.49	8.45	2.15	33.85	19.32	38.45	-19.13	V
844.00	-16.99	3.55	8.36	2.15	33.88	19.55	38.45	-18.90	V

**LTE FDD Band 17\_Channel Bandwidth 5MHz\_QPSK**

Frequency (MHz)	P <sub>Mea</sub> (dBm)	P <sub>cl</sub> (dB)	G <sub>a</sub> Antenna Gain(dB)	Correction (dB)	P <sub>Aq</sub> (dB)	Peak ERP (dBm)	Limit (dBm)	Margin (dB)	Polarization
706.5	-16.10	3.02	8.29	2.15	33.52	20.54	34.77	-14.23	V
710.0	-16.09	3.06	8.29	2.15	33.52	20.51	34.77	-14.26	V
713.5	-16.19	3.06	8.29	2.15	33.52	20.41	34.77	-14.36	V

**LTE FDD Band 17\_Channel Bandwidth 10MHz\_QPSK**

Frequency (MHz)	P <sub>Mea</sub> (dBm)	P <sub>cl</sub> (dB)	G <sub>a</sub> Antenna Gain(dB)	Correction (dB)	P <sub>Aq</sub> (dB)	Peak ERP (dBm)	Limit (dBm)	Margin (dB)	Polarization
709.0	-15.77	3.06	8.29	2.15	33.52	20.83	34.77	-13.94	V
710.0	-16.12	3.06	8.29	2.15	33.52	20.48	34.77	-14.29	V
711.0	-16.26	3.06	8.29	2.15	33.52	20.34	34.77	-14.43	V

**LTE FDD Band 17\_Channel Bandwidth 5MHz\_16QAM**

Frequency (MHz)	P <sub>Mea</sub> (dBm)	P <sub>cl</sub> (dB)	G <sub>a</sub> Antenna Gain(dB)	Correction (dB)	P <sub>Aq</sub> (dB)	Peak ERP (dBm)	Limit (dBm)	Margin (dB)	Polarization
706.5	-16.41	3.02	8.29	2.15	33.52	20.23	34.77	-14.54	V
710.0	-17.06	3.06	8.29	2.15	33.52	19.54	34.77	-15.23	V
713.5	-16.48	3.06	8.29	2.15	33.52	20.12	34.77	-14.65	V

**LTE FDD Band 17\_Channel Bandwidth 10MHz\_16QAM**

Frequency (MHz)	P <sub>Mea</sub> (dBm)	P <sub>cl</sub> (dB)	G <sub>a</sub> Antenna Gain(dB)	Correction (dB)	P <sub>Aq</sub> (dB)	Peak ERP (dBm)	Limit (dBm)	Margin (dB)	Polarization
709.0	-17.01	3.06	8.29	2.15	33.52	19.59	34.77	-15.18	V
710.0	-16.39	3.06	8.29	2.15	33.52	20.21	34.77	-14.56	V
711.0	-16.35	3.06	8.29	2.15	33.52	20.25	34.77	-14.52	V

**LTE TDD Band 41: 2555MHz~2655MHz****LTE TDD Band 41\_Channel Bandwidth 5MHz\_QPSK**

Frequency (MHz)	P <sub>Mea</sub> (dBm)	P <sub>cl</sub> (dB)	G <sub>a</sub> Antenna Gain(dB)	P <sub>Aq</sub> (dB)	Burst Average EIRP (dBm)	Limit (dBm)	Margin (dB)	Polarization
2557.5	-18.06	4.32	6.80	36.13	20.55	30.00	-9.45	V
2605.0	-18.87	4.36	6.55	36.26	19.58	30.00	-10.42	V
2652.5	-18.17	4.51	6.37	36.54	20.23	30.00	-9.77	V

**LTE TDD Band 41\_Channel Bandwidth 10MHz\_QPSK**

Frequency (MHz)	P <sub>Mea</sub> (dBm)	P <sub>cl</sub> (dB)	G <sub>a</sub> Antenna Gain(dB)	P <sub>Aq</sub> (dB)	Burst Average EIRP (dBm)	Limit (dBm)	Margin (dB)	Polarization
2560.0	-18.79	4.32	6.80	36.13	19.82	30.00	-10.18	V
2605.0	-18.65	4.36	6.55	36.26	19.80	30.00	-10.20	V
2650.0	-18.09	4.51	6.37	36.54	20.31	30.00	-9.69	V

**LTE TDD Band 41\_Channel Bandwidth 15MHz\_QPSK**

Frequency (MHz)	P <sub>Mea</sub> (dBm)	P <sub>cl</sub> (dB)	G <sub>a</sub> Antenna Gain(dB)	P <sub>Aq</sub> (dB)	Burst Average EIRP (dBm)	Limit (dBm)	Margin (dB)	Polarization
2562.5	-18.72	4.32	6.80	36.13	19.89	30.00	-10.11	V
2605.0	-18.71	4.36	6.55	36.26	19.74	30.00	-10.26	V
2647.5	-18.98	4.51	6.37	36.54	19.42	30.00	-10.58	V

**LTE TDD Band 41\_Channel Bandwidth 20MHz\_QPSK**

Frequency (MHz)	P <sub>Mea</sub> (dBm)	P <sub>cl</sub> (dB)	G <sub>a</sub> Antenna Gain(dB)	P <sub>Aq</sub> (dB)	Burst Average EIRP (dBm)	Limit (dBm)	Margin (dB)	Polarization
2565.0	-18.59	4.32	6.80	36.13	20.02	30.00	-9.98	V
2605.0	-18.83	4.36	6.55	36.26	19.62	30.00	-10.38	V
2645.0	-18.07	4.51	6.37	36.54	20.33	30.00	-9.67	V

**LTE TDD Band 41\_Channel Bandwidth 5MHz\_16QAM**

Frequency (MHz)	P <sub>Mea</sub> (dBm)	P <sub>cl</sub> (dB)	G <sub>a</sub> Antenna Gain(dB)	P <sub>Aq</sub> (dB)	Burst Average EIRP (dBm)	Limit (dBm)	Margin (dB)	Polarization
2557.5	-19.56	4.32	6.80	36.13	19.05	30.00	-10.95	V
2605.0	-19.41	4.36	6.55	36.26	19.04	30.00	-10.96	V
2652.5	-19.49	4.51	6.37	36.54	18.91	30.00	-11.09	V



**LTE TDD Band 41\_Channel Bandwidth 10MHz\_16QAM**

Frequency (MHz)	P <sub>Mea</sub> (dBm)	P <sub>cl</sub> (dB)	G <sub>a</sub> Antenna Gain(dB)	P <sub>Aq</sub> (dB)	Burst Average EIRP (dBm)	Limit (dBm)	Margin (dB)	Polarization
2560.0	-19.29	4.32	6.80	36.13	19.32	30.00	-10.68	V
2605.0	-19.60	4.36	6.55	36.26	18.85	30.00	-11.15	V
2650.0	-19.65	4.51	6.37	36.54	18.75	30.00	-11.25	V

**LTE TDD Band 41\_Channel Bandwidth 15MHz\_16QAM**

Frequency (MHz)	P <sub>Mea</sub> (dBm)	P <sub>cl</sub> (dB)	G <sub>a</sub> Antenna Gain(dB)	P <sub>Aq</sub> (dB)	Burst Average EIRP (dBm)	Limit (dBm)	Margin (dB)	Polarization
2562.5	-19.51	4.32	6.80	36.13	19.10	30.00	-10.90	V
2605.0	-19.36	4.36	6.55	36.26	19.09	30.00	-10.91	V
2647.5	-19.10	4.51	6.37	36.54	19.30	30.00	-10.70	V

**LTE TDD Band 41\_Channel Bandwidth 20MHz\_16QAM**

Frequency (MHz)	P <sub>Mea</sub> (dBm)	P <sub>cl</sub> (dB)	G <sub>a</sub> Antenna Gain(dB)	P <sub>Aq</sub> (dB)	Burst Average EIRP (dBm)	Limit (dBm)	Margin (dB)	Polarization
2565.0	-19.37	4.32	6.80	36.13	19.24	30.00	-10.76	V
2605.0	-18.98	4.36	6.55	36.26	19.47	30.00	-10.53	V
2645.0	-18.93	4.51	6.37	36.54	19.47	30.00	-10.53	V

## 4.2 Peak-to-Average Ratio (PAR)

### LIMIT

The Peak-to-Average Ratio (PAR) of the transmission may not exceed 13 dB.

### TEST CONFIGURATION

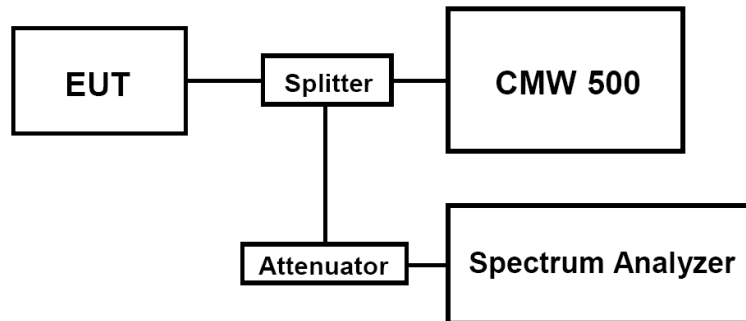

### TEST PROCEDURE

1. Refer to instrument's analyzer instruction manual for details on how to use the power statistics/CCDF function;
2. Set resolution/measurement bandwidth  $\geq$  signal's occupied bandwidth;
3. Set the number of counts to a value that stabilizes the measured CCDF curve;
4. Set the measurement interval as follows:
  - 1). for continuous transmissions, set to 1 ms,
  - 2). for burst transmissions, employ an external trigger that is synchronized with the EUT burst timing sequence, or use the internal burst trigger with a trigger level that allows the burst to stabilize and set the measurement interval to a time that is less than or equal to the burst duration.
5. Record the maximum PAPR level associated with a probability of 0.1%.

### TEST RESULTS

#### *Remark:*

1. We were tested all RB Configuration refer 3GPP TS136 521 for each Channel Bandwidth of LTE FDD Band 2, LTE FDD Band 4, LTE FDD Band 5, LTE FDD Band 17, LTE FDD Band 41; recorded worst case for each Channel Bandwidth of LTE FDD Band 2, LTE FDD Band 4, LTE FDD Band 5, LTE FDD Band 17 and LTE FDD Band 41.
2. For E-UTRA Band 2, please refer to Appendix F: Appendix F.2
3. For E-UTRA Band 4, please refer to Appendix G: Section G.2
4. For E-UTRA Band 5, please refer to Appendix H: Section H.2
5. For E-UTRA Band 17, please refer to Appendix I: Section I.2
6. For E-UTRA Band 41, please refer to Appendix J: Section J.2

### 4.3 Occupied Bandwidth and Emission Bandwidth

#### LIMIT

N/A

#### TEST CONFIGURATION

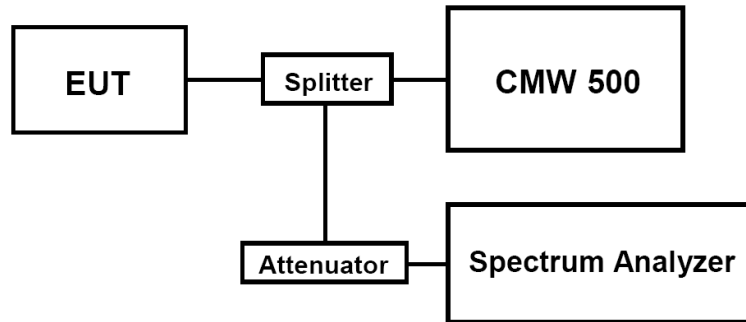

#### TEST PROCEDURE

The transmitter output was connected to a calibrated coaxial cable and coupler, the other end of which was connected to a spectrum analyzer. The occupied bandwidth was measured with the spectrum analyzer at low, middle and high channel in each band. The -26dBc Emission bandwidth was also measured and recorded. Set RBW was set to about 1% of emission BW, VBW $\geq$ 3 times RBW. -26dBc display line was placed on the screen (or 99% bandwidth), the occupied bandwidth is the delta frequency between the two points where the display line intersects the signal trace.

#### TEST RESULTS

Remark:

1. We were tested all RB Configuration refer 3GPP TS136 521 for each Channel Bandwidth of LTE FDD Band 2, LTE FDD Band 4, LTE FDD Band 5, LTE FDD Band 17, LTE FDD Band 41; recorded worst case for each Channel Bandwidth of LTE FDD Band 2, LTE FDD Band 4, LTE FDD Band 5, LTE FDD Band 17 and LTE FDD Band 41.
2. For E-UTRA Band 2, please refer to Appendix F: Appendix F.3
3. For E-UTRA Band 4, please refer to Appendix G: Section G.3
4. For E-UTRA Band 5, please refer to Appendix H: Section H.3
5. For E-UTRA Band 17, please refer to Appendix I: Section I.3
6. For E-UTRA Band 41, please refer to Appendix J: Section J.3

## 4.4 Band Edge compliance

### LIMIT

*For LTE FDD Band 2:* Per FCC §24.238 the power of any emission outside of the authorized operating frequency ranges must be attenuated below the transmitting power (P) by a factor of at least  $43 + 10\log(P)$  dB.

*For LTE FDD Band 4:* Per §27.53(h): For operations in the 1710–1755 MHz and 2110–2155 MHz bands, the power of any emission outside a licensee's frequency block shall be attenuated below the transmitter power (P) by at least  $43 + 10 \log_{10}(P)$  dB.

*For LTE FDD Band 5:* Per FCC §22.917 the power of any emission outside of the authorized operating frequency ranges must be attenuated below the transmitting power (P) by a factor of at least  $43 + 10\log(P)$  dB.

*For LTE FDD Band 17:* Per §27.53(g): (g) For operations in the 600 MHz band and the 698-746 MHz band, the power of any emission outside a licensee's frequency band(s) of operation shall be attenuated below the transmitter power (P) within the licensed band(s) of operation, measured in watts, by at least  $43 + 10 \log(P)$  dB. Compliance with this provision is based on the use of measurement instrumentation employing a resolution bandwidth of 100 kilohertz or greater. However, in the 100 kilohertz bands immediately outside and adjacent to a licensee's frequency block, a resolution bandwidth of at least 30 kHz may be employed.

*For LTE TDD Band 41:* Per §27.53 (m)(6) Measurement procedure. Compliance with these rules is based on the use of measurement instrumentation employing a resolution bandwidth of 1 megahertz or greater. However, in the 1 MHz bands immediately outside and adjacent to the frequency block a resolution bandwidth of at least one percent of the emission bandwidth of the fundamental emission of the transmitter may be employed; for mobile digital stations, in the 1 megahertz bands immediately outside and adjacent to the frequency block a resolution bandwidth of at least two percent may be employed, except when the 1 megahertz band is 2495-2496 MHz, in which case a resolution bandwidth of at least one percent may be employed. A narrower resolution bandwidth is permitted in all cases to improve measurement accuracy provided the measured power is integrated over the full required measurement bandwidth (i.e. 1 megahertz or 1 percent of emission bandwidth, as specified; or 1 megahertz or 2 percent for mobile digital stations, except in the band 2495-2496 MHz). The emission bandwidth is defined as the width of the signal between two points, one below the carrier center frequency and one above the carrier center frequency, outside of which all emissions are attenuated at least 26 dB below the transmitter power. With respect to television operations, measurements must be made of the separate visual and aural operating powers at sufficiently frequent intervals to ensure compliance with the rules.

(m)(4) For mobile digital stations, the attenuation factor shall be not less than  $40 + 10 \log(P)$  dB on all frequencies between the channel edge and 5 megahertz from the channel edge,  $43 + 10 \log(P)$  dB on all frequencies between 5 megahertz and X megahertz from the channel edge, and  $55 + 10 \log(P)$  dB on all frequencies more than X megahertz from the channel edge, where X is the greater of 6 megahertz or the actual emission bandwidth as defined in paragraph (m)(6) of this section. In addition, the attenuation factor shall not be less than  $43 + 10 \log(P)$  dB on all frequencies between 2490.5 MHz and 2496 MHz and  $55 + 10 \log(P)$  dB at or below 2490.5 MHz. Mobile Satellite Service licensees operating on frequencies below 2495 MHz may also submit a documented interference complaint against BRS licensees operating on channel BRS Channel 1 on the same terms and conditions as adjacent channel BRS or EBS licensees. Show citation box.

## TEST CONFIGURATION

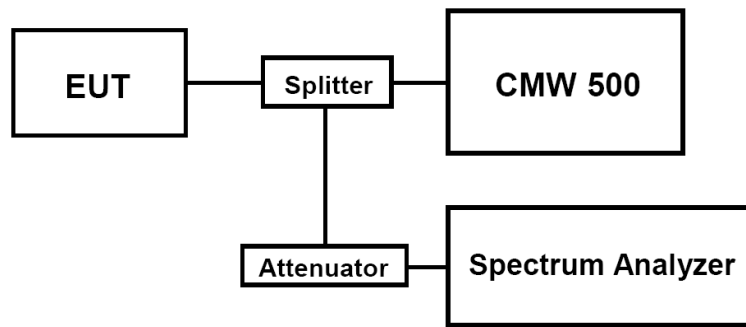

## TEST PROCEDURE

1. The transmitter output port was connected to base station.
2. The RF output of EUT was connected to the power meter by RF cable and attenuator, the path loss was compensated to the results for each measurement.
3. Set EUT at maximum power through base station.
4. Select lowest and highest channels for each band and different modulation.
5. Measure Band edge using RMS (Average) detector by spectrum

**TEST RESULTS***Remark:*

1. We were tested all RB Configuration refer 3GPP TS136 521 for each Channel Bandwidth of LTE FDD Band 2, LTE FDD Band 4, LTE FDD Band 5, LTE FDD Band 17, LTE FDD Band 41; recorded worst case for each Channel Bandwidth of LTE FDD Band 2, LTE FDD Band 4, LTE FDD Band 5, LTE FDD Band 17 and LTE FDD Band 41.
2. For E-UTRA Band 2, please refer to Appendix F: Appendix F.4
3. For E-UTRA Band 4, please refer to Appendix G: Section G.4
4. For E-UTRA Band 5, please refer to Appendix H: Section H.4
5. For E-UTRA Band 17, please refer to Appendix I: Section I.4
6. For E-UTRA Band 41, please refer to Appendix J: Section J.4

## 1.1 Spurious Emission on Antenna Port

### LIMIT

*For LTE FDD Band 2:* Per FCC §24.238 the power of any emission outside of the authorized operating frequency ranges must be attenuated below the transmitting power (P) by a factor of at least  $43 + 10\log(P)$  dB.

*For LTE FDD Band 4:* Per §27.53(h): For operations in the 1710–1755 MHz and 2110–2155 MHz bands, the power of any emission outside a licensee's frequency block shall be attenuated below the transmitter power (P) by at least  $43 + 10 \log_{10}(P)$  dB.

*For LTE FDD Band 5:* Per FCC §22.917 the power of any emission outside of the authorized operating frequency ranges must be attenuated below the transmitting power (P) by a factor of at least  $43 + 10\log(P)$  dB.

*For LTE FDD Band 17:* Per §27.53(g): (g) For operations in the 600 MHz band and the 698-746 MHz band, the power of any emission outside a licensee's frequency band(s) of operation shall be attenuated below the transmitter power (P) within the licensed band(s) of operation, measured in watts, by at least  $43 + 10 \log(P)$  dB. Compliance with this provision is based on the use of measurement instrumentation employing a resolution bandwidth of 100 kilohertz or greater. However, in the 100 kilohertz bands immediately outside and adjacent to a licensee's frequency block, a resolution bandwidth of at least 30 kHz may be employed.

*For LTE TDD Band 41:* Per §27.53 (m)(6) Measurement procedure. Compliance with these rules is based on the use of measurement instrumentation employing a resolution bandwidth of 1 megahertz or greater. However, in the 1 MHz bands immediately outside and adjacent to the frequency block a resolution bandwidth of at least one percent of the emission bandwidth of the fundamental emission of the transmitter may be employed; for mobile digital stations, in the 1 megahertz bands immediately outside and adjacent to the frequency block a resolution bandwidth of at least two percent may be employed, except when the 1 megahertz band is 2495-2496 MHz, in which case a resolution bandwidth of at least one percent may be employed. A narrower resolution bandwidth is permitted in all cases to improve measurement accuracy provided the measured power is integrated over the full required measurement bandwidth (i.e. 1 megahertz or 1 percent of emission bandwidth, as specified; or 1 megahertz or 2 percent for mobile digital stations, except in the band 2495-2496 MHz). The emission bandwidth is defined as the width of the signal between two points, one below the carrier center frequency and one above the carrier center frequency, outside of which all emissions are attenuated at least 26 dB below the transmitter power. With respect to television operations, measurements must be made of the separate visual and aural operating powers at sufficiently frequent intervals to ensure compliance with the rules.

(m)(4) For mobile digital stations, the attenuation factor shall be not less than  $40 + 10 \log(P)$  dB on all frequencies between the channel edge and 5 megahertz from the channel edge,  $43 + 10 \log(P)$  dB on all frequencies between 5 megahertz and X megahertz from the channel edge, and  $55 + 10 \log(P)$  dB on all frequencies more than X megahertz from the channel edge, where X is the greater of 6 megahertz or the actual emission bandwidth as defined in paragraph (m)(6) of this section. In addition, the attenuation factor shall not be less than  $43 + 10 \log(P)$  dB on all frequencies between 2490.5 MHz and 2496 MHz and  $55 + 10 \log(P)$  dB at or below 2490.5 MHz. Mobile Satellite Service licensees operating on frequencies below 2495 MHz may also submit a documented interference complaint against BRS licensees operating on channel BRS Channel 1 on the same terms and conditions as adjacent channel BRS or EBS licensees. Show citation box.

*For LTE FDD Band 66:* Per § 27.53(h): For operations in the 1710 - 1780 MHz and 2110 - 2200 MHz bands, the power of any emission outside a licensee's frequency block shall be attenuated below the transmitter power (P) by at least  $43 + 10 \log_{10}(P)$  dB.

## TEST CONFIGURATION

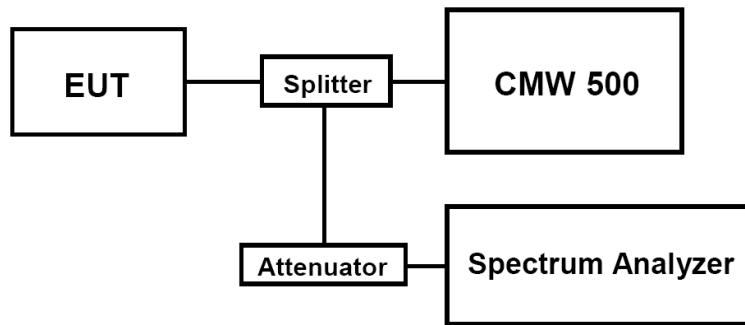

## TEST PROCEDURE

The EUT was setup according to TIA-603-E

- a. Place the EUT on a bench and set it in transmitting mode.
- b. Connect a low loss RF cable from the antenna port to a spectrum analyzer and CMW 500 by a Directional Couple.
- c. EUT Communicate with CMW 500, then select a channel for testing.
- d. Add a correction factor to the display of spectrum, and then test.
- e. The resolution bandwidth of the spectrum analyzer was setsufficient scans were taken to show the out of band Emission if any up to10<sup>th</sup> harmonic.
- f. Please refer to following tables for test antenna conducted emissions.



Working Frequency	Sub range (GHz)	RBW	VBW	Sweep time (s)
LTE FDD Band 2	0.000009~0.000015	1KHz	3KHz	Auto
	0.000015~0.03	10KHz	30KHz	Auto
	0.03~26	1 MHz	3 MHz	Auto
LTE FDD Band 4	0.000009~0.000015	1KHz	3KHz	Auto
	0.000015~0.03	10KHz	30KHz	Auto
	0.03~26	1 MHz	3 MHz	Auto
LTE FDD Band 5	0.000009~0.000015	1KHz	3KHz	Auto
	0.000015~0.03	10KHz	30KHz	Auto
	0.03~26	1 MHz	3 MHz	Auto
LTE FDD Band 17	0.000009~0.000015	1KHz	3KHz	Auto
	0.000015~0.03	10KHz	30KHz	Auto
	0.03~26	1 MHz	3 MHz	Auto
LTE FDD Band 41	0.000009~0.000015	1KHz	3KHz	Auto
	0.000015~0.03	10KHz	30KHz	Auto
	0.03~26	1 MHz	3 MHz	Auto

## **TEST RESULTS**

### *Remark:*

1. We were tested all RB Configuration refer 3GPP TS136 521 for each Channel Bandwidth of LTE FDD Band 2, LTE FDD Band 4, LTE FDD Band 5, LTE FDD Band 17, LTE FDD Band 41; recorded worst case for each Channel Bandwidth of LTE FDD Band 2, LTE FDD Band 4, LTE FDD Band 5, LTE FDD Band 17 and LTE FDD Band 41.
2. For E-UTRA Band 2, please refer to Appendix F: Appendix F.5
3. For E-UTRA Band 4, please refer to Appendix G: Section G.5
4. For E-UTRA Band 5, please refer to Appendix H: Section H.5
5. For E-UTRA Band 17, please refer to Appendix I: Section I.5
6. For E-UTRA Band 41, please refer to Appendix J: Section J.5

## 4.5 Radiated Spurious Emission

### LIMIT

*For LTE FDD Band 2:* Per FCC §24.238 the power of any emission outside of the authorized operating frequency ranges must be attenuated below the transmitting power (P) by a factor of at least  $43 + 10\log(P)$  dB.

*For LTE FDD Band 4:* Per §27.53(h): For operations in the 1710–1755 MHz and 2110–2155 MHz bands, the power of any emission outside a licensee's frequency block shall be attenuated below the transmitter power (P) by at least  $43 + 10 \log_{10}(P)$  dB.

*For LTE FDD Band 5:* Per FCC §22.917 the power of any emission outside of the authorized operating frequency ranges must be attenuated below the transmitting power (P) by a factor of at least  $43 + 10\log(P)$  dB.

*For LTE FDD Band 17:* Per §27.53(g): (g) For operations in the 600 MHz band and the 698-746 MHz band, the power of any emission outside a licensee's frequency band(s) of operation shall be attenuated below the transmitter power (P) within the licensed band(s) of operation, measured in watts, by at least  $43 + 10 \log(P)$  dB. Compliance with this provision is based on the use of measurement instrumentation employing a resolution bandwidth of 100 kilohertz or greater. However, in the 100 kilohertz bands immediately outside and adjacent to a licensee's frequency block, a resolution bandwidth of at least 30 kHz may be employed.

*For LTE TDD Band 41:* Per §27.53 (m)(6) Measurement procedure. Compliance with these rules is based on the use of measurement instrumentation employing a resolution bandwidth of 1 megahertz or greater. However, in the 1 MHz bands immediately outside and adjacent to the frequency block a resolution bandwidth of at least one percent of the emission bandwidth of the fundamental emission of the transmitter may be employed; for mobile digital stations, in the 1 megahertz bands immediately outside and adjacent to the frequency block a resolution bandwidth of at least two percent may be employed, except when the 1 megahertz band is 2495-2496 MHz, in which case a resolution bandwidth of at least one percent may be employed. A narrower resolution bandwidth is permitted in all cases to improve measurement accuracy provided the measured power is integrated over the full required measurement bandwidth (i.e. 1 megahertz or 1 percent of emission bandwidth, as specified; or 1 megahertz or 2 percent for mobile digital stations, except in the band 2495-2496 MHz). The emission bandwidth is defined as the width of the signal between two points, one below the carrier center frequency and one above the carrier center frequency, outside of which all emissions are attenuated at least 26 dB below the transmitter power. With respect to television operations, measurements must be made of the separate visual and aural operating powers at sufficiently frequent intervals to ensure compliance with the rules.

(m)(4) For mobile digital stations, the attenuation factor shall be not less than  $40 + 10 \log(P)$  dB on all frequencies between the channel edge and 5 megahertz from the channel edge,  $43 + 10 \log(P)$  dB on all frequencies between 5 megahertz and X megahertz from the channel edge, and  $55 + 10 \log(P)$  dB on all frequencies more than X megahertz from the channel edge, where X is the greater of 6 megahertz or the actual emission bandwidth as defined in paragraph (m)(6) of this section. In addition, the attenuation factor shall not be less than  $43 + 10 \log(P)$  dB on all frequencies between 2490.5 MHz and 2496 MHz and  $55 + 10 \log(P)$  dB at or below 2490.5 MHz. Mobile Satellite Service licensees operating on frequencies below 2495 MHz may also submit a documented interference complaint against BRS licensees operating on channel BRS Channel 1 on the same terms and conditions as adjacent channel BRS or EBS licensees. Show citation box.

*For LTE FDD Band 66:* Per § 27.53(h): For operations in the 1710 - 1780 MHz and 2110 - 2200 MHz bands, the power of any emission outside a licensee's frequency block shall be attenuated below the transmitter power (P) by at least  $43 + 10 \log_{10}(P)$  dB.

**TEST CONFIGURATION**

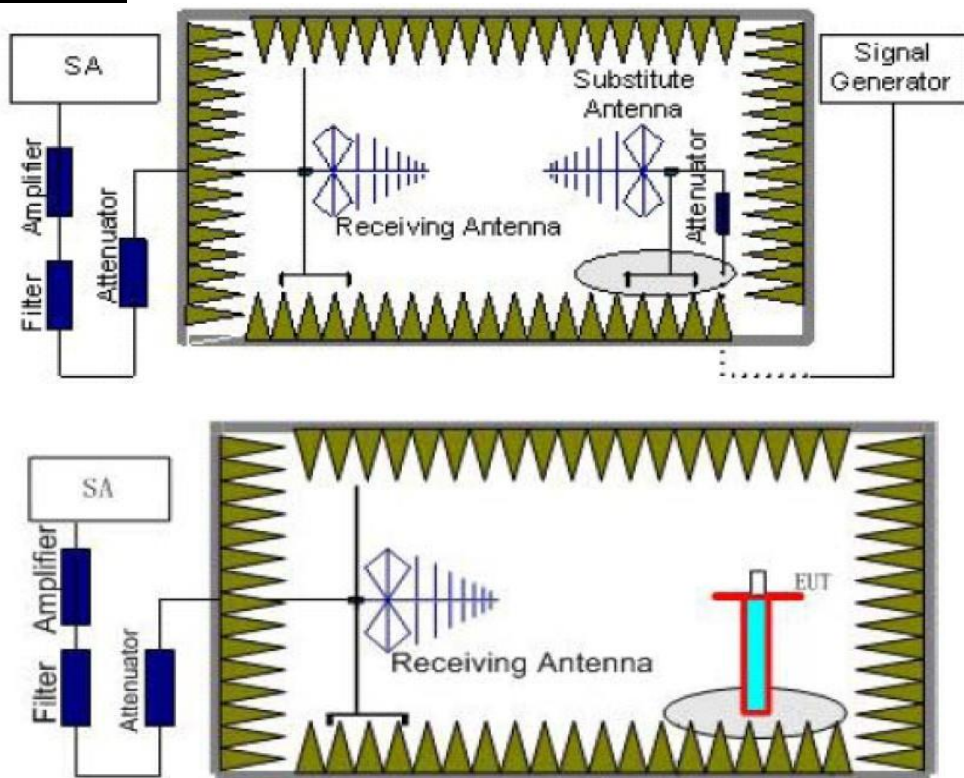

## **TEST PROCEDURE**

1. EUT was placed on a 1.50 meter high non-conductive stand at a 3 meter test distance from the receive antenna. A receiving antenna was placed on the antenna mast 3 meters from the EUT for emission measurements. The height of receiving antenna is 1.50m. Detected emissions were maximized at each frequency by rotating the EUT through 360° and adjusting the receiving antenna polarization. The radiated emission measurements of all transmit frequencies in three channels (High, Middle, Low) were measured with peak detector.
2. A log-periodic antenna or double-ridged waveguide horn antenna shall be substituted in place of the EUT. The log-periodic antenna will be driven by a signal generator and the level will be adjusted till the same power value on the spectrum analyzer or receiver. The level of the spurious emissions can be calculated through the level of the signal generator, cable loss, the gain of the substitution antenna and the reading of the spectrum analyzer or receiver.
3. The EUT is then put into continuously transmitting mode at its maximum power level during the test. Set Test Receiver or Spectrum RBW=1MHz, VBW=3MHz, And the maximum value of the receiver should be recorded as ( $P_r$ ).
4. The EUT shall be replaced by a substitution antenna. In the chamber, an substitution antenna for the frequency band of interest is placed at the reference point of the chamber. An RF Signal source for the frequency band of interest is connected to the substitution antenna with a cable that has been constructed to not interfere with the radiation pattern of the antenna. A power ( $P_{Mea}$ ) is applied to the input of the substitution antenna, and adjust the level of the signal generator output until the value of the receiver reach the previously recorded ( $P_r$ ). The power of signal source ( $P_{Mea}$ ) is recorded. The test should be performed by rotating the test item and adjusting the receiving antenna polarization.
5. A amplifier should be connected to the Signal Source output port. And the cable should be connect between the Amplifier and the Substitution Antenna. The cable loss ( $P_{cl}$ ), the Substitution Antenna Gain ( $G_a$ ) and the Amplifier Gain ( $P_{Ag}$ ) should be recorded after test. The measurement results are obtained as described below:  
Power(EIRP) =  $P_{Mea} + P_{Ag} - P_{cl} + G_a$
6. This value is EIRP since the measurement is calibrated using an antenna of known gain (2.15 dBi) and known input power.
7. ERP can be calculated from EIRP by subtracting the gain of the dipole, ERP = EIRP - 2.15dBi.
8. In order to make sure test results more clearly, we set frequency range and sweep time for difference frequency range as follows table:

Working Frequency	Subrange (GHz)	RBW	VBW	Sweep time (s)
LTE FDD Band 2	0.00009~0.15	1KHz	3KHz	30
	0.00015~0.03	10KHz	30KHz	10
	0.03~1	100KHz	300KHz	10
	1~2	1 MHz	3 MHz	2
	2~5	1 MHz	3 MHz	3
	5~8	1 MHz	3 MHz	3
	8~11	1 MHz	3 MHz	3
	11~14	1 MHz	3 MHz	3
	14~18	1 MHz	3 MHz	3
LTE FDD Band 4	0.00009~0.15	1KHz	3KHz	30
	0.00015~0.03	10KHz	30KHz	10
	0.03~1	100KHz	300KHz	10
	1~2	1 MHz	3 MHz	2
	2~5	1 MHz	3 MHz	3
	5~8	1 MHz	3 MHz	3
	8~11	1 MHz	3 MHz	3
	11~14	1 MHz	3 MHz	3
	14~18	1 MHz	3 MHz	3
LTE FDD Band 5	0.00009~0.15	1KHz	3KHz	30
	0.00015~0.03	10KHz	30KHz	10
	0.03~1	100KHz	300KHz	10
	1~2	1 MHz	3 MHz	2
	2~5	1 MHz	3 MHz	3
	5~8	1 MHz	3 MHz	3
	8~9	1 MHz	3 MHz	3
LTE FDD Band 17	0.00009~0.15	1KHz	3KHz	30
	0.00015~0.03	10KHz	30KHz	10
	0.03~1	100KHz	300KHz	10
	1~2	1 MHz	3 MHz	2
	2~5	1 MHz	3 MHz	3
	5~8	1 MHz	3 MHz	3
LTE TDD Band 41	0.00009~0.15	1KHz	3KHz	30
	0.00015~0.03	10KHz	30KHz	10
	0.03~1	100KHz	300KHz	10
	1~2	1 MHz	3 MHz	2
	2~5	1 MHz	3 MHz	3
	5~8	1 MHz	3 MHz	3
	8~11	1 MHz	3 MHz	3
	11~14	1 MHz	3 MHz	3
	14~18	1 MHz	3 MHz	3
	18~20	1 MHz	3 MHz	2
	20~26	1 MHz	3 MHz	2

Frequency	Channel	Frequency Range	Verdict
LTE FDD Band 2	Low	9KHz -20GHz	PASS
	Middle	9KHz -20GHz	PASS
	High	9KHz -20GHz	PASS
LTE FDD Band 4	Low	9KHz -18GHz	PASS
	Middle	9KHz -18GHz	PASS
	High	9KHz -18GHz	PASS
LTE FDD Band 5	Low	9KHz -9GHz	PASS
	Middle	9KHz -9GHz	PASS
	High	9KHz -9GHz	PASS
LTE FDD Band 17	Low	9KHz -8GHz	PASS
	Middle	9KHz -8GHz	PASS
	High	9KHz -8GHz	PASS
LTE TDD Band 41	Low	9KHz -26GHz	PASS
	Middle	9KHz -26GHz	PASS
	High	9KHz -26GHz	PASS

## **TEST RESULTS**

*Remark:*

1. We were tested all RB Configuration refer 3GPP TS136 521 for each Channel Bandwidth of LTE FDD Band 2, LTE FDD Band 4, LTE FDD Band 5, LTE FDD Band 17 and LTE Band 41; recorded worst case for each Channel Bandwidth of LTE FDD Band 2, LTE FDD Band 4, LTE FDD Band 5, LTE FDD Band 17 and LTE Band 41.
3. We were not recorded other points as values lower than limits.
4.  $Power(EIRP) = P_{Mea} + P_{Ag} - P_{cl} + G_a$
5.  $Margin = EIRP - Limit$

*LTE FDD Band 2\_Channel Bandwidth 20MHz\_QPSK\_Low Channel*

Frequency (MHz)	P <sub>Mea</sub> (dBm)	P <sub>cl</sub> (dB)	Diatance	G <sub>a</sub> Antenna Gain(dB)	Peak EIRP (dBm)	Limit (dBm)	Margin (dB)	Polarization
3715.0	-39.42	5.26	3.00	9.88	-34.80	-13.00	-21.80	H
5572.5	-46.04	6.11	3.00	11.36	-40.79	-13.00	-27.79	H
3715.0	-29.88	5.26	3.00	9.88	-25.26	-13.00	-12.26	V
5572.5	-36.91	6.11	3.00	11.36	-31.66	-13.00	-18.66	V

*LTE FDD Band 2\_Channel Bandwidth 20MHz\_QPSK\_Middle Channel*

Frequency (MHz)	P <sub>Mea</sub> (dBm)	P <sub>cl</sub> (dB)	Diatance	G <sub>a</sub> Antenna Gain(dB)	Peak EIRP (dBm)	Limit (dBm)	Margin (dB)	Polarization
3720.0	-37.34	5.32	3.00	10.03	-32.63	-13.00	-19.63	H
5580.0	-46.33	6.19	3.00	11.41	-41.11	-13.00	-28.11	H
3720.0	-31.85	5.32	3.00	10.03	-27.14	-13.00	-14.14	V
5580.0	-36.17	6.19	3.00	11.41	-30.95	-13.00	-17.95	V

*LTE FDD Band 2\_Channel Bandwidth 20MHz\_QPSK\_High Channel*

Frequency (MHz)	P <sub>Mea</sub> (dBm)	P <sub>cl</sub> (dB)	Diatance	G <sub>a</sub> Antenna Gain(dB)	Peak EIRP (dBm)	Limit (dBm)	Margin (dB)	Polarization
3800.0	-37.26	5.36	3.00	9.62	-33.00	-13.00	-20.00	H
5700.0	-46.92	6.24	3.00	11.46	-41.70	-13.00	-28.70	H
3800.0	-30.55	5.36	3.00	9.62	-26.29	-13.00	-13.29	V
5700.0	-34.75	6.24	3.00	11.46	-29.53	-13.00	-16.53	V

*LTE FDD Band 2\_Channel Bandwidth 20MHz\_16QAM\_Low Channel*

Frequency (MHz)	P <sub>Mea</sub> (dBm)	P <sub>cl</sub> (dB)	Diatance	G <sub>a</sub> Antenna Gain(dB)	Peak EIRP (dBm)	Limit (dBm)	Margin (dB)	Polarization
3715.0	-41.72	5.26	3.00	9.88	-37.10	-13.00	-24.10	H
5572.5	-46.86	6.11	3.00	11.36	-41.61	-13.00	-28.61	H
3715.0	-31.07	5.26	3.00	9.88	-26.45	-13.00	-13.45	V
5572.5	-39.74	6.11	3.00	11.36	-34.49	-13.00	-21.49	V

*LTE FDD Band 2\_Channel Bandwidth 20MHz\_16QAM\_Middle Channel*

Frequency (MHz)	P <sub>Mea</sub> (dBm)	P <sub>cl</sub> (dB)	Diatance	G <sub>a</sub> Antenna Gain(dB)	Peak EIRP (dBm)	Limit (dBm)	Margin (dB)	Polarization
3720.0	-42.23	5.32	3.00	10.03	-37.52	-13.00	-24.52	H
5580.0	-47.41	6.19	3.00	11.41	-42.19	-13.00	-29.19	H
3720.0	-32.24	5.32	3.00	10.03	-27.53	-13.00	-14.53	V
5580.0	-40.05	6.19	3.00	11.41	-34.83	-13.00	-21.83	V

*LTE FDD Band 2\_Channel Bandwidth 20MHz\_16QAM\_High Channel*

Frequency (MHz)	P <sub>Mea</sub> (dBm)	P <sub>cl</sub> (dB)	Diatance	G <sub>a</sub> Antenna Gain(dB)	Peak EIRP (dBm)	Limit (dBm)	Margin (dB)	Polarization
3800.0	-41.32	5.36	3.00	9.62	-37.06	-13.00	-24.06	H
5700.0	-48.84	6.24	3.00	11.46	-43.62	-13.00	-30.62	H
3800.0	-32.52	5.36	3.00	9.62	-28.26	-13.00	-15.26	V
5700.0	-41.26	6.24	3.00	11.46	-36.04	-13.00	-23.04	V

*LTE FDD Band 4\_Channel Bandwidth 20MHz\_QPSK\_Low Channel*

Frequency (MHz)	P <sub>Mea</sub> (dBm)	P <sub>cl</sub> (dB)	Diatance	G <sub>a</sub> Antenna Gain(dB)	Peak EIRP (dBm)	Limit (dBm)	Margin (dB)	Polarization
3440.0	-41.78	4.62	3.00	9.81	-36.59	-13.00	-23.59	H
5160.0	-46.76	5.94	3.00	10.86	-41.84	-13.00	-28.84	H
3440.0	-34.77	4.62	3.00	9.81	-29.58	-13.00	-16.58	V
5160.0	-38.01	5.94	3.00	10.86	-33.09	-13.00	-20.09	V

*LTE FDD Band 4\_Channel Bandwidth 20MHz\_QPSK\_Middle Channel*

Frequency (MHz)	P <sub>Mea</sub> (dBm)	P <sub>cl</sub> (dB)	Diatance	G <sub>a</sub> Antenna Gain(dB)	Peak EIRP (dBm)	Limit (dBm)	Margin (dB)	Polarization
3465.0	-42.63	4.63	3.00	9.84	-37.42	-13.00	-24.42	H
5197.5	-45.33	5.94	3.00	10.86	-40.41	-13.00	-27.41	H
3465.0	-35.15	4.63	3.00	9.84	-29.94	-13.00	-16.94	V
5197.5	-41.17	5.94	3.00	10.86	-36.25	-13.00	-23.25	V

*LTE FDD Band 4\_Channel Bandwidth 20MHz\_QPSK\_High Channel*

Frequency (MHz)	P <sub>Mea</sub> (dBm)	P <sub>cl</sub> (dB)	Diatance	G <sub>a</sub> Antenna Gain(dB)	Peak EIRP (dBm)	Limit (dBm)	Margin (dB)	Polarization
3490.0	-43.85	4.65	3.00	9.90	-38.60	-13.00	-25.60	H
5235.0	-48.57	5.95	3.00	10.91	-43.61	-13.00	-30.61	H
3490.0	-33.67	4.65	3.00	9.90	-28.42	-13.00	-15.42	V
5235.0	-39.43	5.95	3.00	10.91	-34.47	-13.00	-21.47	V

*LTE FDD Band 4\_Channel Bandwidth 20MHz\_16QAM\_Low Channel*

Frequency (MHz)	P <sub>Mea</sub> (dBm)	P <sub>cl</sub> (dB)	Diatance	G <sub>a</sub> Antenna Gain(dB)	Peak EIRP (dBm)	Limit (dBm)	Margin (dB)	Polarization
3440.0	-44.78	4.62	3.00	9.81	-39.59	-13.00	-26.59	H
5160.0	-51.59	5.94	3.00	10.86	-46.67	-13.00	-33.67	H
3440.0	-39.43	4.62	3.00	9.81	-34.24	-13.00	-21.24	V
5160.0	-43.47	5.94	3.00	10.86	-38.55	-13.00	-25.55	V

*LTE FDD Band 4\_Channel Bandwidth 20MHz\_16QAM\_Middle Channel*

Frequency (MHz)	P <sub>Mea</sub> (dBm)	P <sub>cl</sub> (dB)	Diatance	G <sub>a</sub> Antenna Gain(dB)	Peak EIRP (dBm)	Limit (dBm)	Margin (dB)	Polarization
3465.0	-45.40	4.63	3.00	9.84	-40.19	-13.00	-27.19	H
5197.5	-48.03	5.94	3.00	10.86	-43.11	-13.00	-30.11	H
3465.0	-37.92	4.63	3.00	9.84	-32.71	-13.00	-19.71	V
5197.5	-44.95	5.94	3.00	10.86	-40.03	-13.00	-27.03	V

*LTE FDD Band 4\_Channel Bandwidth 20MHz\_16QAM\_High Channel*

Frequency (MHz)	P <sub>Mea</sub> (dBm)	P <sub>cl</sub> (dB)	Diatance	G <sub>a</sub> Antenna Gain(dB)	Peak EIRP (dBm)	Limit (dBm)	Margin (dB)	Polarization
3490.0	-44.32	4.65	3.00	9.90	-39.07	-13.00	-26.07	H
5235.0	-49.34	5.95	3.00	10.91	-44.38	-13.00	-31.38	H
3490.0	-38.10	4.65	3.00	9.90	-32.85	-13.00	-19.85	V
5235.0	-43.41	5.95	3.00	10.91	-38.45	-13.00	-25.45	V



*LTE FDD Band 5\_Channel Bandwidth 10MHz\_QPSK\_Low Channel*

Frequency (MHz)	P <sub>Mea</sub> (dBm)	P <sub>cl</sub> (dB)	Diatance	G <sub>a</sub> Antenna Gain(dB)	Peak EIRP (dBm)	Limit (dBm)	Margin (dB)	Polarization
1658.00	-39.97	3.86	3.00	8.56	-35.27	-13.00	-22.27	H
2487.00	-47.52	4.29	3.00	6.98	-44.83	-13.00	-31.83	H
1658.00	-34.19	3.86	3.00	8.56	-29.49	-13.00	-16.49	V
2487.00	-36.35	4.29	3.00	6.98	-33.66	-13.00	-20.66	V

*LTE FDD Band 5\_Channel Bandwidth 10MHz\_QPSK\_Middle Channel*

Frequency (MHz)	P <sub>Mea</sub> (dBm)	P <sub>cl</sub> (dB)	Diatance	G <sub>a</sub> Antenna Gain(dB)	Peak EIRP (dBm)	Limit (dBm)	Margin (dB)	Polarization
1673.00	-40.43	3.90	3.00	8.58	-35.75	-13.00	-22.75	H
2509.50	-44.93	4.32	3.00	6.80	-42.45	-13.00	-29.45	H
1673.00	-36.78	3.90	3.00	8.58	-32.10	-13.00	-19.10	V
2509.50	-36.15	4.32	3.00	6.80	-33.67	-13.00	-20.67	V

*LTE FDD Band 5\_Channel Bandwidth 10MHz\_QPSK\_High Channel*

Frequency (MHz)	P <sub>Mea</sub> (dBm)	P <sub>cl</sub> (dB)	Diatance	G <sub>a</sub> Antenna Gain(dB)	Peak EIRP (dBm)	Limit (dBm)	Margin (dB)	Polarization
1688.00	-41.50	3.91	3.00	9.06	-36.35	-13.00	-23.35	H
2532.00	-46.87	4.32	3.00	6.65	-44.54	-13.00	-31.54	H
1688.00	-34.26	3.91	3.00	9.06	-29.11	-13.00	-16.11	V
2532.00	-36.79	4.32	3.00	6.65	-34.46	-13.00	-21.46	V

*LTE FDD Band 5\_Channel Bandwidth 10MHz\_16QAM\_Low Channel*

Frequency (MHz)	P <sub>Mea</sub> (dBm)	P <sub>cl</sub> (dB)	Diatance	G <sub>a</sub> Antenna Gain(dB)	Peak EIRP (dBm)	Limit (dBm)	Margin (dB)	Polarization
1658.00	-41.19	3.86	3.00	8.56	-36.49	-13.00	-23.49	H
2487.00	-49.05	4.29	3.00	6.98	-46.36	-13.00	-33.36	H
1658.00	-39.78	3.86	3.00	8.56	-35.08	-13.00	-22.08	V
2487.00	-42.24	4.29	3.00	6.98	-39.55	-13.00	-26.55	V

*LTE FDD Band 5\_Channel Bandwidth 10MHz\_16QAM\_Middle Channel*

Frequency (MHz)	P <sub>Mea</sub> (dBm)	P <sub>cl</sub> (dB)	Diatance	G <sub>a</sub> Antenna Gain(dB)	Peak EIRP (dBm)	Limit (dBm)	Margin (dB)	Polarization
1673.00	-41.56	3.90	3.00	8.58	-36.88	-13.00	-23.88	H
2509.50	-49.75	4.32	3.00	6.80	-47.27	-13.00	-34.27	H
1673.00	-36.74	3.90	3.00	8.58	-32.06	-13.00	-19.06	V
2509.50	-42.35	4.32	3.00	6.80	-39.87	-13.00	-26.87	V

*LTE FDD Band 5\_Channel Bandwidth 10MHz\_16QAM\_High Channel*

Frequency (MHz)	P <sub>Mea</sub> (dBm)	P <sub>cl</sub> (dB)	Diatance	G <sub>a</sub> Antenna Gain(dB)	Peak EIRP (dBm)	Limit (dBm)	Margin (dB)	Polarization
1688.00	-42.81	3.91	3.00	9.06	-37.66	-13.00	-24.66	H
2532.00	-48.91	4.32	3.00	6.65	-46.58	-13.00	-33.58	H
1688.00	-37.58	3.91	3.00	9.06	-32.43	-13.00	-19.43	V
2532.00	-41.58	4.32	3.00	6.65	-39.25	-13.00	-26.25	V

**LTE FDD Band 17\_Channel Bandwidth 10MHz\_QPSK\_Low Channel**

Frequency (MHz)	P <sub>Mea</sub> (dBm)	P <sub>cl</sub> (dB)	Diatance	G <sub>a</sub> Antenna Gain(dB)	Peak EIRP (dBm)	Limit (dBm)	Margin (dB)	Polarization
1418.0	-39.29	3.72	3.00	9.04	-33.97	-13.00	-20.97	H
2127.0	-44.99	4.23	3.00	8.60	-40.62	-13.00	-27.62	H
1418.0	-34.55	3.72	3.00	9.04	-29.23	-13.00	-16.23	V
2127.0	-39.97	4.23	3.00	8.60	-35.60	-13.00	-22.60	V

**LTE FDD Band 17\_Channel Bandwidth 10MHz\_QPSK\_Middle Channel**

Frequency (MHz)	P <sub>Mea</sub> (dBm)	P <sub>cl</sub> (dB)	Diatance	G <sub>a</sub> Antenna Gain(dB)	Peak EIRP (dBm)	Limit (dBm)	Margin (dB)	Polarization
1420.0	-40.24	4.78	3.00	8.91	-36.11	-13.00	-23.11	H
2130.0	-46.34	4.25	3.00	8.26	-42.33	-13.00	-29.33	H
1420.0	-35.64	4.78	3.00	8.91	-31.51	-13.00	-18.51	V
2130.0	-37.72	4.25	3.00	8.26	-33.71	-13.00	-20.71	V

**LTE FDD Band 17\_Channel Bandwidth 10MHz\_QPSK\_High Channel**

Frequency (MHz)	P <sub>Mea</sub> (dBm)	P <sub>cl</sub> (dB)	Diatance	G <sub>a</sub> Antenna Gain(dB)	Peak EIRP (dBm)	Limit (dBm)	Margin (dB)	Polarization
1422.0	-41.63	4.78	3.00	8.91	-37.50	-13.00	-24.50	H
2133.0	-46.04	4.25	3.00	8.26	-42.03	-13.00	-29.03	H
1422.0	-34.61	4.78	3.00	8.91	-30.48	-13.00	-17.48	V
2133.0	-39.96	4.25	3.00	8.26	-35.95	-13.00	-22.95	V

**LTE FDD Band 17\_Channel Bandwidth 10MHz\_16QAM\_Low Channel**

Frequency (MHz)	P <sub>Mea</sub> (dBm)	P <sub>cl</sub> (dB)	Diatance	G <sub>a</sub> Antenna Gain(dB)	Peak EIRP (dBm)	Limit (dBm)	Margin (dB)	Polarization
1418.0	-41.05	3.72	3.00	9.04	-35.73	-13.00	-22.73	H
2127.0	-44.64	4.23	3.00	8.60	-40.27	-13.00	-27.27	H
1418.0	-33.91	3.72	3.00	9.04	-28.59	-13.00	-15.59	V
2127.0	-39.77	4.23	3.00	8.60	-35.40	-13.00	-22.40	V

**LTE FDD Band 17\_Channel Bandwidth 10MHz\_16QAM\_Middle Channel**

Frequency (MHz)	P <sub>Mea</sub> (dBm)	P <sub>cl</sub> (dB)	Diatance	G <sub>a</sub> Antenna Gain(dB)	Peak EIRP (dBm)	Limit (dBm)	Margin (dB)	Polarization
1420.0	-41.48	4.78	3.00	8.91	-37.35	-13.00	-24.35	H
2130.0	-47.98	4.25	3.00	8.26	-43.97	-13.00	-30.97	H
1420.0	-35.77	4.78	3.00	8.91	-31.64	-13.00	-18.64	V
2130.0	-36.75	4.25	3.00	8.26	-32.74	-13.00	-19.74	V

**LTE FDD Band 17\_Channel Bandwidth 10MHz\_16QAM\_High Channel**

Frequency (MHz)	P <sub>Mea</sub> (dBm)	P <sub>cl</sub> (dB)	Diatance	G <sub>a</sub> Antenna Gain(dB)	Peak EIRP (dBm)	Limit (dBm)	Margin (dB)	Polarization
1422.0	-40.28	4.78	3.00	8.91	-36.15	-13.00	-23.15	H
2133.0	-45.19	4.25	3.00	8.26	-41.18	-13.00	-28.18	H
1422.0	-35.85	4.78	3.00	8.91	-31.72	-13.00	-18.72	V
2133.0	-39.17	4.25	3.00	8.26	-35.16	-13.00	-22.16	V

**LTE TDD Band 41: 2555MHz~2655MHz***LTE TDD Band 41\_Channel Bandwidth 20MHz\_QPSK\_Low Channel*

Frequency (MHz)	P <sub>Mea</sub> (dBm)	P <sub>cl</sub> (dB)	Diatance	G <sub>a</sub> Antenna Gain(dB)	Peak EIRP (dBm)	Limit (dBm)	Margin (dB)	Polarization
5130.0	-40.34	7.15	3.00	9.88	-37.61	-25.00	-12.61	H
7695.0	-47.68	8.36	3.00	11.36	-44.68	-25.00	-19.68	H
5130.0	-35.85	7.15	3.00	9.88	-33.12	-25.00	-8.12	V
7695.0	-39.77	8.36	3.00	11.36	-36.77	-25.00	-11.77	V

*LTE TDD Band 41\_Channel Bandwidth 20MHz\_QPSK\_Middle Channel*

Frequency (MHz)	P <sub>Mea</sub> (dBm)	P <sub>cl</sub> (dB)	Diatance	G <sub>a</sub> Antenna Gain(dB)	Peak EIRP (dBm)	Limit (dBm)	Margin (dB)	Polarization
5210.0	-40.71	7.26	3.00	10.03	-37.94	-25.00	-12.94	H
7815.0	-47.25	8.48	3.00	11.41	-44.32	-25.00	-19.32	H
5210.0	-36.06	7.26	3.00	10.03	-33.29	-25.00	-8.29	V
7815.0	-39.00	8.48	3.00	11.41	-36.07	-25.00	-11.07	V

*LTE TDD Band 41\_Channel Bandwidth 20MHz\_QPSK\_High Channel*

Frequency (MHz)	P <sub>Mea</sub> (dBm)	P <sub>cl</sub> (dB)	Diatance	G <sub>a</sub> Antenna Gain(dB)	Peak EIRP (dBm)	Limit (dBm)	Margin (dB)	Polarization
5290.0	-38.73	7.17	3.00	9.62	-36.28	-25.00	-11.28	H
7935.0	-44.02	8.39	3.00	11.46	-40.95	-25.00	-15.95	H
5290.0	-35.60	7.17	3.00	9.62	-33.15	-25.00	-8.15	V
7935.0	-38.57	8.39	3.00	11.46	-35.50	-25.00	-10.50	V

*LTE TDD Band 41\_Channel Bandwidth 20MHz\_16QAM\_Low Channel*

Frequency (MHz)	P <sub>Mea</sub> (dBm)	P <sub>cl</sub> (dB)	Diatance	G <sub>a</sub> Antenna Gain(dB)	Peak EIRP (dBm)	Limit (dBm)	Margin (dB)	Polarization
5130.0	-43.70	7.15	3.00	9.88	-40.97	-25.00	-15.97	H
7695.0	-49.15	8.36	3.00	11.36	-46.15	-25.00	-21.15	H
5130.0	-36.65	7.15	3.00	9.88	-33.92	-25.00	-8.92	V
7695.0	-40.79	8.36	3.00	11.36	-37.79	-25.00	-12.79	V

*LTE TDD Band 41\_Channel Bandwidth 20MHz\_16QAM\_Middle Channel*

Frequency (MHz)	P <sub>Mea</sub> (dBm)	P <sub>cl</sub> (dB)	Diatance	G <sub>a</sub> Antenna Gain(dB)	Peak EIRP (dBm)	Limit (dBm)	Margin (dB)	Polarization
5210.0	-43.08	7.26	3.00	10.03	-40.31	-25.00	-15.31	H
7815.0	-49.07	8.48	3.00	11.41	-46.14	-25.00	-21.14	H
5210.0	-38.98	7.26	3.00	10.03	-36.21	-25.00	-11.21	V
7815.0	-40.50	8.48	3.00	11.41	-37.57	-25.00	-12.57	V

*LTE TDD Band 41\_Channel Bandwidth 20MHz\_16QAM\_High Channel*

Frequency (MHz)	P <sub>Mea</sub> (dBm)	P <sub>cl</sub> (dB)	Diatance	G <sub>a</sub> Antenna Gain(dB)	Peak EIRP (dBm)	Limit (dBm)	Margin (dB)	Polarization
5290.0	-41.71	7.17	3.00	9.62	-39.26	-25.00	-14.26	H
7935.0	-46.03	8.39	3.00	11.46	-42.96	-25.00	-17.96	H
5290.0	-39.19	7.17	3.00	9.62	-36.74	-25.00	-11.74	V
7935.0	-42.86	8.39	3.00	11.46	-39.79	-25.00	-14.79	V

Notes: All channel bandwidth were tested, the report recorded the worst data.

## 4.6 Frequency Stability under Temperature & Voltage Variations

### LIMIT

- § 2.1055(a), 2.1055(d),
- § 22.355, the carrier frequency of each transmitter in the Public Mobile Services must be maintained within the tolerances given in Table C-1 of this section.  
For Mobile devices operating in the 824 to 849 MHz band at a power level less than or equal to 3 Watts, the limit specified in Table C-1 is +/- 2.5 ppm.
- § 24.235, the frequency stability shall be sufficient to ensure that the fundamental emission stays within the authorized frequency block.
- § 27.54, the frequency stability shall be sufficient to ensure that the fundamental emission stays within the authorized bands of operation.

### TEST CONFIGURATION

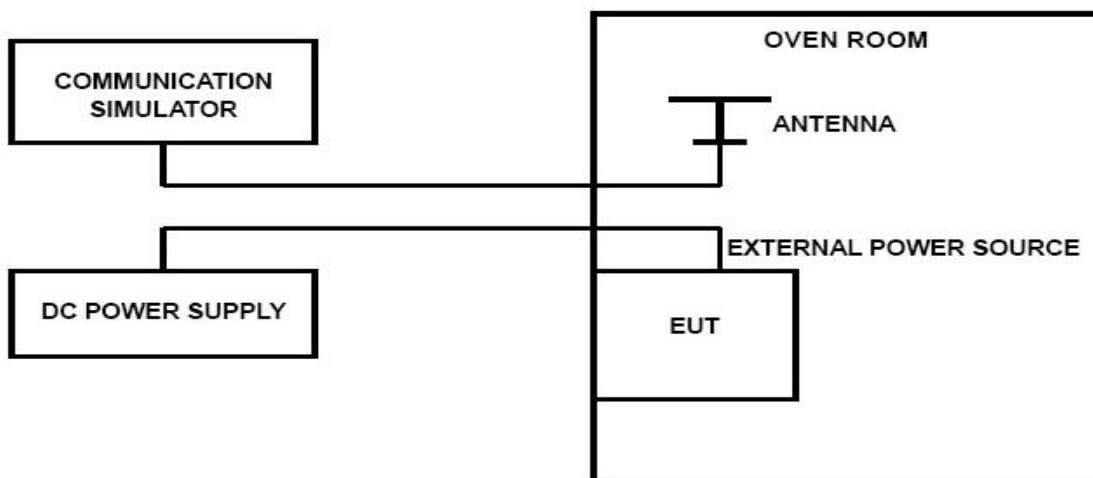

### TEST PROCEDURE

The EUT was setup according to TIA-603-E

#### **Frequency Stability Under Temperature Variations:**

In order to measure the carrier frequency under the condition of AFC lock, it is necessary to make measurements with the EUT in a "call mode". This is accomplished with the use of R&S CMW 500 DIGITAL RADIO COMMUNICATION TESTER.

1. Measure the carrier frequency at room temperature.
2. Subject the EUT to overnight soak at -30°C.
3. With the EUT, powered via nominal voltage, connected to the CMW 500 and in a simulated call on middle channel for LTE band 2, LTE band 4, LTE band 5, LTE band 7 and LTE Band 17; measure the carrier frequency. These measurements should be made within 2 minutes of Powering up the EUT, to prevent significant self-warming.
4. Repeat the above measurements at 10°C increments from -30°C to +50°C. Allow at least 1.5 hours at each temperature, unpowered, before making measurements.
5. Re-measure carrier frequency at room temperature with nominal voltage. Vary supply voltage from minimum voltage to maximum voltage, in 0.1Volt increments re-measuring carrier frequency at each voltage. Pause at nominal voltage for 1.5 hours unpowered, to allow any self-heating to stabilize, before continuing.
6. Subject the EUT to overnight soak at +50°C.
7. With the EUT, powered via nominal voltage, connected to the CMW 500 and in a simulated call on the centre channel, measure the carrier frequency. These measurements should be made within 2 minutes of Powering up the EUT, to prevent significant self-warming.
8. Repeat the above measurements at 10 °C increments from +50°C to -30°C. Allow at least 1.5 hours at each temperature, unpowered, before making measurements
9. At all temperature levels hold the temperature to +/- 0.5°C during the measurement procedure.

**Frequency Stability Under Voltage Variations:**

For Hand carried battery powered equipment

According to the JTC standard the frequency stability of the carrier shall be accurate to within 0.1 ppm of the received frequency from the base station. The frequency stability shall be sufficient to ensure that the fundamental emission stays within the authorized frequency block. As this transceiver is considered "Hand carried, battery powered equipment" Section 2.1055(d)(2) applies. This requires that the lower voltage for frequency stability testing be specified by the manufacturer. This transceiver is specified to operate with an input voltage of between 3.3VDC and 4.2VDC, with a nominal voltage of 3.7DC.

**TEST RESULTS***Remark:*

We were tested all RB Configuration refer 3GPP TS136 521 for each Channel Bandwidth of LTE FDD Band 2, LTE FDD Band 4, LTE FDD Band 5, LTE FDD Band 17, LTE FDD Band 41; recorded worst case for each Channel Bandwidth of LTE FDD Band 2, LTE FDD Band 4, LTE FDD Band 5, LTE FDD Band 17 and LTE FDD Band 41.

*LTE Band 2, QPSK, 1.4MHz bandwidth (worst case of all bandwidths)*

LTE FDD Band 2					
DC Power	Temperature (°C)	Frequency error(Hz)	Frequency error(ppm)	Limit (ppm)	Verdict
3.6	25	-5	-0.003	±2.50	PASS
3.8	25	0	0.000	±2.50	PASS
4.35	25	-3	-0.002	±2.50	PASS
3.8	-30	-3	-0.002	±2.50	PASS
3.8	-20	-7	-0.004	±2.50	PASS
3.8	-10	14	0.007	±2.50	PASS
3.8	0	-17	-0.009	±2.50	PASS
3.8	10	-3	-0.002	±2.50	PASS
3.8	20	-20	-0.011	±2.50	PASS
3.8	30	-18	-0.010	±2.50	PASS
3.8	40	6	0.003	±2.50	PASS
3.8	50	15	0.008	±2.50	PASS

*LTE Band 2, 16QAM, 1.4MHz bandwidth (worst case of all bandwidths)*

LTE FDD Band 2					
DC Power	Temperature (°C)	Frequency error(Hz)	Frequency error(ppm)	Limit (ppm)	Verdict
3.6	25	16	0.009	±2.50	PASS
3.8	25	-11	-0.006	±2.50	PASS
4.35	25	-5	-0.003	±2.50	PASS
3.8	-30	15	0.008	±2.50	PASS
3.8	-20	-11	-0.006	±2.50	PASS
3.8	-10	10	0.005	±2.50	PASS
3.8	0	5	0.003	±2.50	PASS
3.8	10	-12	-0.006	±2.50	PASS
3.8	20	-12	-0.006	±2.50	PASS
3.8	30	-16	-0.009	±2.50	PASS
3.8	40	-8	-0.004	±2.50	PASS
3.8	50	-2	-0.001	±2.50	PASS

## LTE Band 4, QPSK, 1.4MHz bandwidth (worst case of all bandwidths)

LTE FDD Band 4					
DC Power	Temperature (°C)	Frequency error(Hz)	Frequency error(ppm)	Limit (ppm)	Verdict
3.6	25	36	0.021	±2.50	PASS
3.8	25	33	0.019	±2.50	PASS
4.35	25	33	0.019	±2.50	PASS
3.8	-30	-29	-0.017	±2.50	PASS
3.8	-20	25	0.014	±2.50	PASS
3.8	-10	-38	-0.022	±2.50	PASS
3.8	0	-5	-0.003	±2.50	PASS
3.8	10	0	0.000	±2.50	PASS
3.8	20	-11	-0.006	±2.50	PASS
3.8	30	-35	-0.020	±2.50	PASS
3.8	40	-36	-0.021	±2.50	PASS
3.8	50	37	0.021	±2.50	PASS

## LTE Band 4, 16QAM, 1.4MHz bandwidth (worst case of all bandwidths)

LTE FDD Band 4					
DC Power	Temperature (°C)	Frequency error(Hz)	Frequency error(ppm)	Limit (ppm)	Verdict
3.6	25	45	0.026	±2.50	PASS
3.8	25	-35	-0.020	±2.50	PASS
4.35	25	9	0.005	±2.50	PASS
3.8	-30	35	0.020	±2.50	PASS
3.8	-20	-2	-0.001	±2.50	PASS
3.8	-10	-44	-0.025	±2.50	PASS
3.8	0	-28	-0.016	±2.50	PASS
3.8	10	28	0.016	±2.50	PASS
3.8	20	-19	-0.011	±2.50	PASS
3.8	30	49	0.028	±2.50	PASS
3.8	40	-45	-0.026	±2.50	PASS
3.8	50	-45	-0.026	±2.50	PASS

## LTE Band 5, QPSK, 1.4MHz bandwidth(worst case of all bandwidths)

LTE FDD Band 5					
DC Power	Temperature (°C)	Frequency error(Hz)	Frequency error(ppm)	Limit (ppm)	Verdict
3.6	25	-4	-0.005	±2.50	PASS
3.8	25	-15	-0.018	±2.50	PASS
4.35	25	20	0.024	±2.50	PASS
3.8	-30	40	0.049	±2.50	PASS
3.8	-20	2	0.002	±2.50	PASS
3.8	-10	-16	-0.019	±2.50	PASS
3.8	0	44	0.053	±2.50	PASS
3.8	10	-9	-0.011	±2.50	PASS
3.8	20	-49	-0.059	±2.50	PASS
3.8	30	-27	-0.033	±2.50	PASS
3.8	40	43	0.052	±2.50	PASS
3.8	50	-44	-0.053	±2.50	PASS

## LTE Band 5, 16QAM, 1.4MHz bandwidth(worst case of all bandwidths)

LTE FDD Band 5					
DC Power	Temperature (°C)	Frequency error(Hz)	Frequency error(ppm)	Limit (ppm)	Verdict
3.6	25	49	0.059	±2.50	PASS
3.8	25	-31	-0.038	±2.50	PASS
4.35	25	14	0.017	±2.50	PASS
3.8	-30	-23	-0.028	±2.50	PASS
3.8	-20	41	0.050	±2.50	PASS
3.8	-10	-49	-0.059	±2.50	PASS
3.8	0	27	0.033	±2.50	PASS
3.8	10	42	0.051	±2.50	PASS
3.8	20	-41	-0.050	±2.50	PASS
3.8	30	38	0.046	±2.50	PASS
3.8	40	44	0.053	±2.50	PASS
3.8	50	32	0.039	±2.50	PASS

## LTE Band 17, QPSK, 5MHz bandwidth (worst case of all bandwidths and modulation type)

LTE FDD Band 17					
DC Power	Temperature (°C)	Frequency error(Hz)	Frequency error(ppm)	Limit (ppm)	Verdict
3.6	25	-50	-0.070	±2.50	PASS
3.8	25	-11	-0.015	±2.50	PASS
4.35	25	-20	-0.028	±2.50	PASS
3.8	-30	18	0.025	±2.50	PASS
3.8	-20	6	0.008	±2.50	PASS
3.8	-10	36	0.051	±2.50	PASS
3.8	0	38	0.054	±2.50	PASS
3.8	10	4	0.006	±2.50	PASS
3.8	20	50	0.070	±2.50	PASS
3.8	30	9	0.013	±2.50	PASS
3.8	40	-16	-0.023	±2.50	PASS
3.8	50	-30	-0.042	±2.50	PASS

## LTE Band 17, 16QAM, 5MHz bandwidth (worst case of all bandwidths and modulation type)

LTE FDD Band 17					
DC Power	Temperature (°C)	Frequency error(Hz)	Frequency error(ppm)	Limit (ppm)	Verdict
3.6	25	-27	-0.038	±2.50	PASS
3.8	25	-17	-0.024	±2.50	PASS
4.35	25	0	0.000	±2.50	PASS
3.8	-30	-30	-0.042	±2.50	PASS
3.8	-20	-20	-0.028	±2.50	PASS
3.8	-10	-26	-0.037	±2.50	PASS
3.8	0	-8	-0.011	±2.50	PASS
3.8	10	-5	-0.007	±2.50	PASS
3.8	20	14	0.020	±2.50	PASS
3.8	30	-44	-0.062	±2.50	PASS
3.8	40	-45	-0.063	±2.50	PASS
3.8	50	-12	-0.017	±2.50	PASS

## LTE Band 41, 5MHz bandwidth, QPSK (worst case of all bandwidths)

LTE TDD Band 41					
DC Power	Temperature (°C)	Frequency error(Hz)	Frequency error(ppm)	Limit (ppm)	Verdict
3.6	20	65	0.031	2.50	PASS
3.8	20	11	0.005	2.50	PASS
4.35	20	96	0.046	2.50	PASS
3.7	-30	2	0.001	2.50	PASS
3.7	-20	35	0.017	2.50	PASS
3.7	-10	90	0.043	2.50	PASS
3.7	0	93	0.044	2.50	PASS
3.7	10	66	0.032	2.50	PASS
3.7	20	90	0.043	2.50	PASS
3.7	30	12	0.006	2.50	PASS
3.7	40	87	0.042	2.50	PASS
3.7	50	60	0.029	2.50	PASS

## LTE Band 41, 5MHz bandwidth, 16QAM (worst case of all bandwidths)

LTE TDD Band 41					
DC Power	Temperature (°C)	Frequency error(Hz)	Frequency error(ppm)	Limit (ppm)	Verdict
3.6	20	59	0.028	2.50	PASS
3.8	20	46	0.022	2.50	PASS
4.35	20	38	0.018	2.50	PASS
3.7	-30	87	0.042	2.50	PASS
3.7	-20	43	0.021	2.50	PASS
3.7	-10	44	0.021	2.50	PASS
3.7	0	44	0.021	2.50	PASS
3.7	10	90	0.043	2.50	PASS
3.7	20	79	0.038	2.50	PASS
3.7	30	65	0.031	2.50	PASS
3.7	40	41	0.020	2.50	PASS
3.7	50	3	0.001	2.50	PASS

Note: The EUT is hand carried battery powered equipment.



## **5 Test Setup Photos of the EUT**

Pleaserefer to separated files for Test Setup Photos of the EUT.

## **6 External Photos of the EUT**

Pleaserefer to separated files for External Photos of the EUT.

## **7 Internal Photos of the EUT**

Pleaserefer to separated files for Internal Photos of the EUT.

**\*\*\*\*\*End of Report\*\*\*\*\***