

TEST REPORT

Applicant: Shenzhen Renwei Digital Technology Co., Ltd

Address of Applicant: Room 403, building B3, Hongwan maker center, Gushu Town, Bao'an District, Shenzhen, China

Manufacturer: Shenzhen Renwei Digital Technology Co., Ltd

Address of Manufacturer: Room 403, building B3, Hongwan maker center, Gushu Town, Bao'an District, Shenzhen, China

Equipment Under Test (EUT)

Product Name: Ntelligent visual ceramic ear spoon

Model No.: V105, V106, V107, V108, V109, V11, V12, V13, V15, V16

Trade Mark: N/A

FCC ID: 2AYIR-V105

Applicable standards: FCC CFR Title 47 Part 15 Subpart C Section 15.247

Date of sample receipt: Dec. 17, 2020

Date of Test: Dec. 17, 2020 - Dec. 22, 2020

Date of report issued: Dec. 22, 2020

Test Result: PASS *

* In the configuration tested, the EUT complied with the standards specified above.

Authorized Signature:



Robinson Lo
Laboratory Manager

This results shown in this test report refer only to the sample(s) tested, this test report cannot be reproduced, except in full, without prior written permission of the company. The report would be invalid without specific stamp of test institute and the signatures of compiler and approver.

2 Version

Version No.	Date	Description
00	Dec. 22, 2020	Original

Prepared By:



Date:

Dec. 22, 2020

Project Engineer

Check By:



Date:

Dec. 22, 2020

Reviewer

3 Contents

	Page
1 COVER PAGE	1
2 VERSION	2
3 CONTENTS	3
4 TEST SUMMARY	4
5 GENERAL INFORMATION	5
5.1 GENERAL DESCRIPTION OF EUT	5
5.2 TEST MODE	7
5.3 DESCRIPTION OF SUPPORT UNITS	7
5.4 DEVIATION FROM STANDARDS	7
5.5 ABNORMALITIES FROM STANDARD CONDITIONS	7
5.6 TEST FACILITY	7
5.7 TEST LOCATION	7
5.8 ADDITIONAL INSTRUCTIONS	7
6 TEST INSTRUMENTS LIST	8
7 TEST RESULTS AND MEASUREMENT DATA	10
7.1 ANTENNA REQUIREMENT	10
7.2 CONDUCTED EMISSIONS	11
7.3 CONDUCTED PEAK OUTPUT POWER	14
7.4 CHANNEL BANDWIDTH & 99% OCCUPY BANDWIDTH	15
7.5 POWER SPECTRAL DENSITY	17
7.6 BAND EDGES	19
7.6.1 Conducted Emission Method	19
7.6.2 Radiated Emission Method	21
7.7 SPURIOUS EMISSION	24
7.7.1 Conducted Emission Method	24
7.7.2 Radiated Emission Method	26
8 TEST SETUP PHOTO	37
9 EUT CONSTRUCTIONAL DETAILS	37

4 Test Summary

Test Item	Section	Result
Antenna requirement	FCC part 15.203/15.247 (c)	Pass
AC Power Line Conducted Emission	FCC part 15.207	Pass
Conducted Peak Output Power	FCC part 15.247 (b)(3)	Pass
Channel Bandwidth & 99% OCB	FCC part 15.247 (a)(2)	Pass
Power Spectral Density	FCC part 15.247 (e)	Pass
Band Edge	FCC part 15.247(d)	Pass
Spurious Emission	FCC part 15.205/15.209	Pass

Remark: Test according to ANSI C63.10:2013 and RSS-Gen

Pass: The EUT complies with the essential requirements in the standard.

Measurement Uncertainty

Test Item	Frequency Range	Measurement Uncertainty	Notes
Radiated Emission	30MHz-200MHz	3.8039dB	(1)
Radiated Emission	200MHz-1GHz	3.9679dB	(1)
Radiated Emission	1GHz-18GHz	4.29dB	(1)
Radiated Emission	18GHz-40GHz	3.30dB	(1)
AC Power Line Conducted Emission	0.15MHz ~ 30MHz	3.44dB	(1)

Note (1): The measurement uncertainty is for coverage factor of k=2 and a level of confidence of 95%.

5 General Information

5.1 General Description of EUT

Product Name:	Ntelligent visual ceramic ear spoon
Model No.:	V105, V106, V107, V108, V109, V11, V12, V13, V15, V16
Serial No.:	/
Hardware Version:	HV01
Software Version:	SV01
Test sample(s) ID:	GTSL202012000272F01
Sample(s) Status:	Engineer sample
Channel numbers:	802.11b/802.11g: 11
Channel separation:	5MHz
Modulation technology:	802.11b: Direct Sequence Spread Spectrum (DSSS)
Antenna Type:	Internal antenna
Antenna gain:	1.8dBi
Power supply:	DC 3.7V from battery DC 5V from charger

Operation Frequency each of channel							
Channel	Frequency	Channel	Frequency	Channel	Frequency	Channel	Frequency
1	2412MHz	4	2427MHz	7	2442MHz	10	2457MHz
2	2417MHz	5	2432MHz	8	2447MHz	11	2462MHz
3	2422MHz	6	2437MHz	9	2452MHz	X	

Note:

In section 15.31(m), regards to the operating frequency range over 10 MHz, the Lowest frequency, the middle frequency, and the highest frequency of channel were selected to perform the test, and the selected channel see below:

Test channel	Frequency (MHz)	
	802.11b/802.11g	
Lowest channel	2412MHz	
Middle channel	2437MHz	
Highest channel	2462MHz	

5.2 Test mode

Transmitting mode	Keep the EUT in continuously transmitting mode
<i>Remark: During the test, the duty cycle >98%, the test voltage was tuned from 85% to 115% of the nominal rated supply voltage, and found that the worst case was under the nominal rated supply condition. So the report just shows that condition's data.</i>	

We have verified the construction and function in typical operation. All the test modes were carried out with the EUT in transmitting operation, which was shown in this test report and defined as follows:				
Pre-scan all kind of data rate in lowest channel, and found the follow list which it was worst case.				
Mode	802.11b	802.11g		
Data rate	1Mbps	6Mbps		

5.3 Description of Support Units

None.

5.4 Deviation from Standards

None.

5.5 Abnormalities from Standard Conditions

None.

5.6 Test Facility

<p>The test facility is recognized, certified, or accredited by the following organizations:</p> <ul style="list-style-type: none"> ● FCC —Registration No.: 381383 Global United Technology Services Co., Ltd., Shenzhen EMC Laboratory has been registered and fully described in a report filed with the (FCC) Federal Communications Commission. The acceptance letter from the FCC is maintained in files. Registration 381383. ● IC —Registration No.: 9079A The 3m Semi-anechoic chamber of Global United Technology Services Co., Ltd. has been registered by Certification and Engineering Bureau of Industry Canada for radio equipment testing with Registration No.: 9079A ● NVLAP (LAB CODE:600179-0) Global United Technology Services Co., Ltd., is accredited by the National Voluntary Laboratory Accreditation Program (NVLAP). LAB CODE:600179-0

5.7 Test Location

All tests were performed at:
<p>Global United Technology Services Co., Ltd. Address: No. 123-128, Tower A, Jinyuan Business Building, No.2, Laodong Industrial Zone, Xixiang Road, Baoan District, Shenzhen, Guangdong, China 518102 Tel: 0755-27798480 Fax: 0755-27798960</p>

5.8 Additional Instructions

Test Software	Special test command provided by manufacturer
Power level setup	Default

6 Test Instruments list

Radiated Emission:						
Item	Test Equipment	Manufacturer	Model No.	Inventory No.	Cal.Date (mm-dd-yy)	Cal.Due date (mm-dd-yy)
1	3m Semi- Anechoic Chamber	ZhongYu Electron	9.2(L)*6.2(W)* 6.4(H)	GTS250	July. 02 2020	July. 01 2025
2	Control Room	ZhongYu Electron	6.2(L)*2.5(W)* 2.4(H)	GTS251	N/A	N/A
3	EMI Test Receiver	Rohde & Schwarz	ESU26	GTS203	June. 25 2020	June. 24 2021
4	BiConiLog Antenna	SCHWARZBECK MESS-ELEKTRONIK	VULB9163	GTS214	June. 25 2020	June. 24 2021
5	Double -ridged waveguide horn	SCHWARZBECK MESS-ELEKTRONIK	BBHA 9120 D	GTS208	June. 25 2020	June. 24 2021
6	Horn Antenna	ETS-LINDGREN	3160	GTS217	June. 25 2020	June. 24 2021
7	EMI Test Software	AUDIX	E3	N/A	N/A	N/A
8	Coaxial Cable	GTS	N/A	GTS213	June. 25 2020	June. 24 2021
9	Coaxial Cable	GTS	N/A	GTS211	June. 25 2020	June. 24 2021
10	Coaxial cable	GTS	N/A	GTS210	June. 25 2020	June. 24 2021
11	Coaxial Cable	GTS	N/A	GTS212	June. 25 2020	June. 24 2021
12	Amplifier(100kHz-3GHz)	HP	8347A	GTS204	June. 25 2020	June. 24 2021
13	Amplifier(2GHz-20GHz)	HP	84722A	GTS206	June. 25 2020	June. 24 2021
14	Amplifier (18-26GHz)	Rohde & Schwarz	AFS33-18002 650-30-8P-44	GTS218	June. 25 2020	June. 24 2021
15	Band filter	Amindeon	82346	GTS219	June. 25 2020	June. 24 2021
16	Power Meter	Anritsu	ML2495A	GTS540	June. 25 2020	June. 24 2021
17	Power Sensor	Anritsu	MA2411B	GTS541	June. 25 2020	June. 24 2021
18	Wideband Radio Communication Tester	Rohde & Schwarz	CMW500	GTS575	June. 25 2020	June. 24 2021
19	Splitter	Agilent	11636B	GTS237	June. 25 2020	June. 24 2021
20	Loop Antenna	ZHINAN	ZN30900A	GTS534	June. 25 2020	June. 24 2021
21	Breitband hornantenne	SCHWARZBECK	BBHA 9170	GTS579	Oct. 18 2020	Oct. 17 2021
22	Amplifier	TDK	PA-02-02	GTS574	Oct. 18 2020	Oct. 17 2021
23	Amplifier	TDK	PA-02-03	GTS576	Oct. 18 2020	Oct. 17 2021
24	PSA Series Spectrum Analyzer	Rohde & Schwarz	FSP	GTS578	June. 25 2020	June. 24 2021

Conducted Emission						
Item	Test Equipment	Manufacturer	Model No.	Inventory No.	Cal.Date (mm-dd-yy)	Cal.Due date (mm-dd-yy)
1	Shielding Room	ZhongYu Electron	7.3(L)x3.1(W)x2.9(H)	GTS252	May.15 2019	May.14 2022
2	EMI Test Receiver	R&S	ESCI 7	GTS552	June. 25 2020	June. 24 2021
3	Coaxial Switch	ANRITSU CORP	MP59B	GTS225	June. 25 2020	June. 24 2021
4	ENV216 2-L-V-NETZNACHB.DE	ROHDE&SCHWARZ	ENV216	GTS226	June. 25 2020	June. 24 2021
5	Coaxial Cable	GTS	N/A	GTS227	N/A	N/A
6	EMI Test Software	AUDIX	E3	N/A	N/A	N/A
7	Thermo meter	KTJ	TA328	GTS233	June. 25 2020	June. 24 2021
8	Absorbing clamp	Elektronik-Feinmechanik	MDS21	GTS229	June. 25 2020	June. 24 2021
9	ISN	SCHWARZBECK	NTFM 8158	GTD565	June. 25 2020	June. 24 2021

RF Conducted Test:						
Item	Test Equipment	Manufacturer	Model No.	Serial No.	Cal.Date (mm-dd-yy)	Cal.Due date (mm-dd-yy)
1	MXA Signal Analyzer	Agilent	N9020A	GTS566	June. 25 2020	June. 24 2021
2	EMI Test Receiver	R&S	ESCI 7	GTS552	June. 25 2020	June. 24 2021
3	Spectrum Analyzer	Agilent	E4440A	GTS533	June. 25 2020	June. 24 2021
4	MXG vector Signal Generator	Agilent	N5182A	GTS567	June. 25 2020	June. 24 2021
5	ESG Analog Signal Generator	Agilent	E4428C	GTS568	June. 25 2020	June. 24 2021
6	USB RF Power Sensor	DARE	RPR3006W	GTS569	June. 25 2020	June. 24 2021
7	RF Switch Box	Shongyi	RFSW3003328	GTS571	June. 25 2020	June. 24 2021
8	Programmable Constant Temp & Humi Test Chamber	WEWON	WHTH-150L-40-880	GTS572	June. 25 2020	June. 24 2021

General used equipment:						
Item	Test Equipment	Manufacturer	Model No.	Inventory No.	Cal.Date (mm-dd-yy)	Cal.Due date (mm-dd-yy)
1	Humidity/ Temperature Indicator	KTJ	TA328	GTS243	June. 25 2020	June. 24 2021
2	Barometer	ChangChun	DYM3	GTS255	June. 25 2020	June. 24 2021

7 Test results and Measurement Data

7.1 Antenna requirement

Standard requirement:	FCC Part15 C Section 15.203 /247(c)
<p>15.203 requirement:</p> <p>An intentional radiator shall be designed to ensure that no antenna other than that furnished by the responsible party shall be used with the device. The use of a permanently attached antenna or of an antenna that uses a unique coupling to the intentional radiator, the manufacturer may design the unit so that a broken antenna can be replaced by the user, but the use of a standard antenna jack or electrical connector is prohibited.</p> <p>15.247(c) (1)(i) requirement:</p> <p>(i) Systems operating in the 2400-2483.5 MHz band that is used exclusively for fixed. Point-to-point operations may employ transmitting antennas with directional gain greater than 6dBi provided the maximum conducted output power of the intentional radiator is reduced by 1 dB for every 3 dB that the directional gain of the antenna exceeds 6dBi.</p>	
EUT Antenna:	
<p>The antennas are PCB antenna, the best case gain of the antennas are 2dBi, reference to the appendix II for details</p>	

7.2 Conducted Emissions

Test Requirement:	FCC Part15 C Section 15.207					
Test Method:	ANSI C63.10:2013					
Test Frequency Range:	150KHz to 30MHz					
Receiver setup:	RBW=9KHz, VBW=30KHz, Sweep time=auto					
Limit:	Frequency range (MHz)		Limit (dBuV)			
			Quasi-peak		Average	
	0.15-0.5		66 to 56*		56 to 46*	
	0.5-5		56		46	
	5-30		60		50	
* Decreases with the logarithm of the frequency.						
Test setup:	<p>Remark: E.U.T: Equipment Under Test LISN: Line Impedance Stabilization Network Test table height=0.8m</p>					
Test procedure:	<ol style="list-style-type: none"> 1. The E.U.T and simulators are connected to the main power through a line impedance stabilization network (L.I.S.N.). This provides a 50ohm/50uH coupling impedance for the measuring equipment. 2. The peripheral devices are also connected to the main power through a LISN that provides a 50ohm/50uH coupling impedance with 50ohm termination. (Please refer to the block diagram of the test setup and photographs). 3. Both sides of A.C. line are checked for maximum conducted interference. In order to find the maximum emission, the relative positions of equipment and all of the interface cables must be changed according to ANSI C63.10:2013 on conducted measurement. 					
Test Instruments:	Refer to section 6.0 for details					
Test mode:	Refer to section 5.2 for details					
Test environment:	Temp.:	25 °C	Humid.:	52%	Press.:	1012mbar
Test voltage:	AC 120V, 60Hz					
Test results:	Pass					

Remark: Both high and low voltages have been tested to show only the worst low voltage test data.

Measurement data

Line:

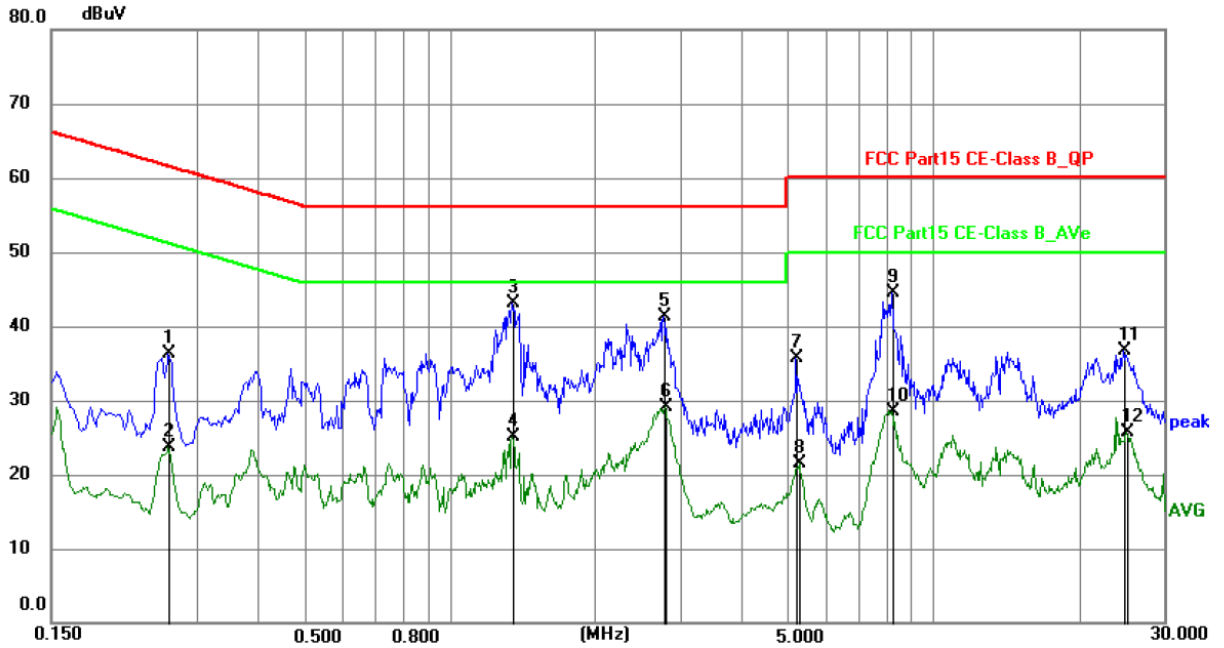

No.	Frequency (MHz)	Reading (dBuV)	Factor (dB)	Level (dBuV)	Limit (dBuV)	Margin (dB)	Detector
1	0.2625	26.78	9.51	36.29	61.35	25.06	QP
2	0.2625	14.10	9.51	23.61	51.35	27.74	AVG
3	1.3469	33.80	9.24	43.04	56.00	12.96	QP
4	1.3469	15.87	9.24	25.11	46.00	20.89	AVG
5	2.7690	32.12	9.15	41.27	56.00	14.73	QP
6	2.7825	19.96	9.15	29.11	46.00	16.89	AVG
7	5.2170	26.73	8.96	35.69	60.00	24.31	QP
8	5.2980	12.61	8.97	21.58	50.00	28.42	AVG
9	8.2094	35.13	9.30	44.43	60.00	15.57	QP
10	8.2094	19.15	9.30	28.45	50.00	21.55	AVG
11	24.6975	27.18	9.52	36.70	60.00	23.30	QP
12	25.1205	16.19	9.53	25.72	50.00	24.28	AVG

Neutral:

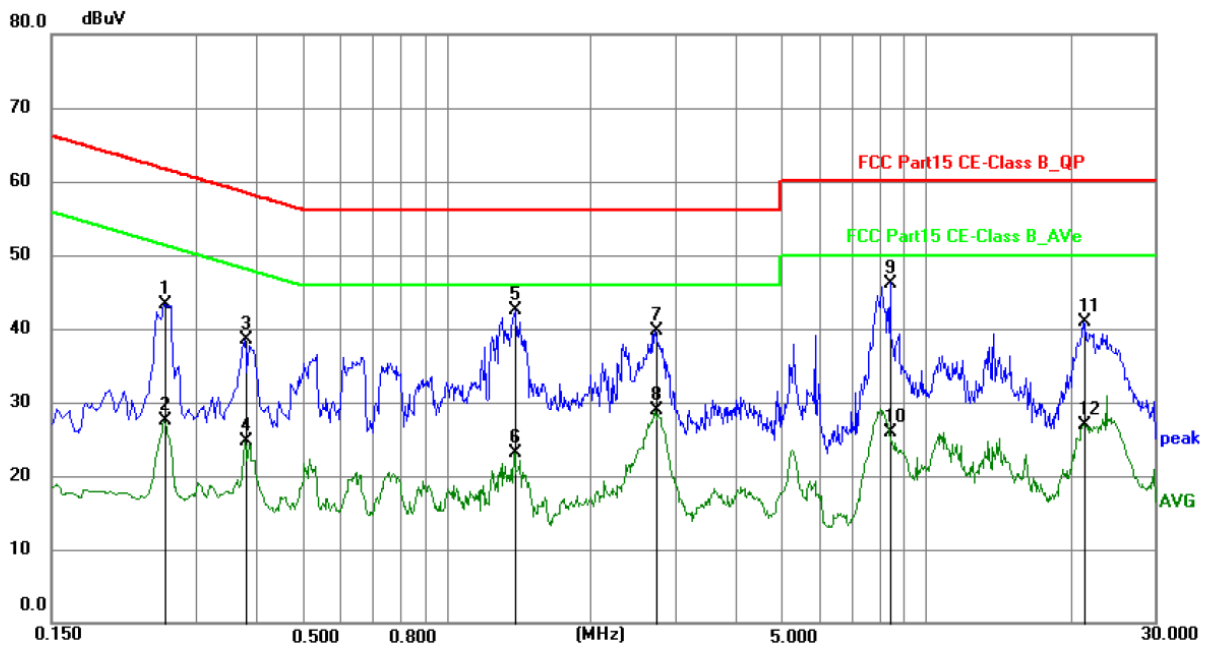

No.	Frequency (MHz)	Reading (dBuV)	Factor (dB)	Level (dBuV)	Limit (dBuV)	Margin (dB)	Detector
1	0.2580	34.32	9.07	43.39	61.50	18.11	QP
2	0.2580	18.43	9.07	27.50	51.50	24.00	AVG
3	0.3795	29.56	8.92	38.48	58.29	19.81	QP
4	0.3795	15.76	8.92	24.68	48.29	23.61	AVG
5	1.3920	33.61	8.91	42.52	56.00	13.48	QP
6	1.3920	14.16	8.91	23.07	46.00	22.93	AVG
7	2.7330	30.54	9.18	39.72	56.00	16.28	QP
8	2.7330	19.75	9.18	28.93	46.00	17.07	AVG
9	8.4210	36.91	9.29	46.20	60.00	13.80	QP
10	8.4210	16.66	9.29	25.95	50.00	24.05	AVG
11	21.3450	31.32	9.60	40.92	60.00	19.08	QP
12	21.3450	17.28	9.60	26.88	50.00	23.12	AVG

Notes:

1. An initial pre-scan was performed on the line and neutral lines with peak detector.
2. Quasi-Peak and Average measurement were performed at the frequencies with maximized peak emission.
3. Final Level = Receiver Read level + LISN Factor + Cable Loss
4. If the average limit is met when using a quasi-peak detector receiver, the EUT shall be deemed to meet both limits and measurement with the average detector receiver is unnecessary.

7.3 Conducted Peak Output Power

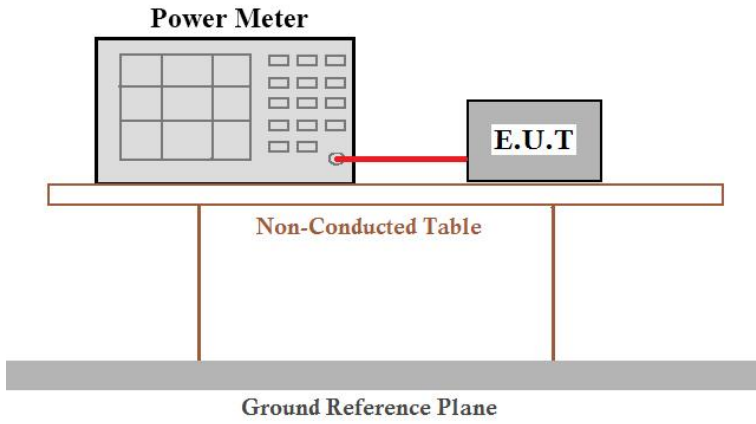
Test Requirement :	FCC Part15 C Section 15.247 (b)(3)
Test Method :	KDB558074 D01 DTS Meas Guidance v05or02
Limit:	30dBm
Test setup:	 <p>The diagram illustrates the test setup. A Power Meter is connected to an E.U.T. (Equipment Under Test) via a red cable. Both are placed on a Non-Conducted Table, which is supported by two legs. Below the table is a Ground Reference Plane.</p>
Test Instruments:	Refer to section 6.0 for details
Test mode:	Refer to section 5.2 for details
Test results:	Pass

Measurement Data

Test CH	Peak Output Power (dBm)		Limit(dBm)	Result
	802.11b	802.11g		
Lowest	8.331	7.759	30.00	Pass
Middle	8.339	7.776		
Highest	8.352	7.544		

7.4 Channel Bandwidth & 99% Occupancy Bandwidth

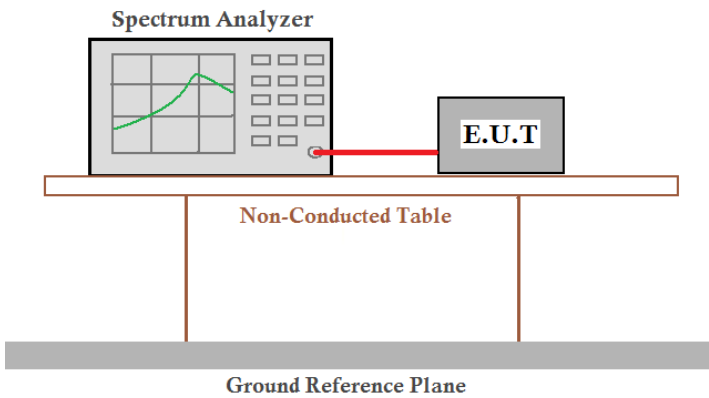
Test Requirement :	FCC Part15 C Section 15.247 (a)(2)
Test Method :	KDB558074 D01 DTS Meas Guidance v05or02
Limit:	>500KHz
Test setup:	 <p>The diagram illustrates the test setup. A Spectrum Analyzer is connected to an E.U.T. (Equipment Under Test) via a red cable. Both are placed on a Non-Conducted Table, which is supported by a Ground Reference Plane.</p>
Test Instruments:	Refer to section 6.0 for details
Test mode:	Refer to section 5.2 for details
Test results:	Pass

Measurement Data

Test CH	Channel Bandwidth (MHz)		Limit(KHz)	Result
	802.11b	802.11g		
Lowest	9.06	15.70	>500	Pass
Middle	9.58	15.95		
Highest	9.58	15.70		

Test plot as follows:

802.11b	802.11g
---------	---------

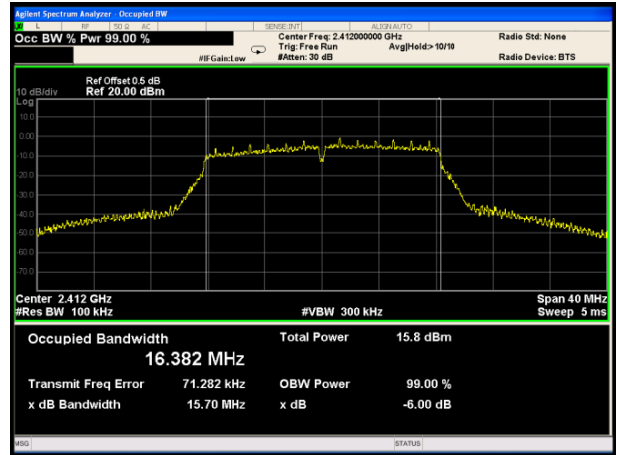
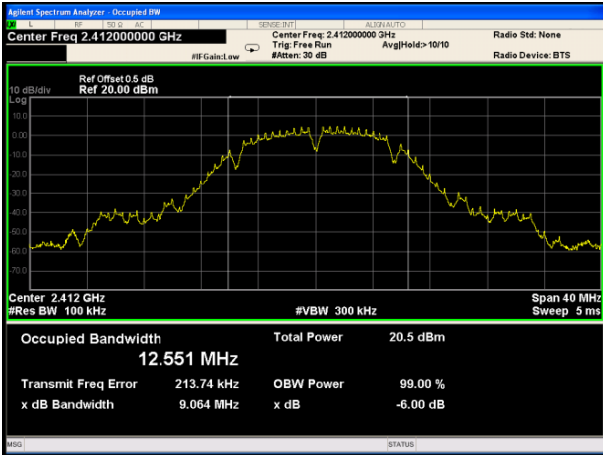

Lowest channel

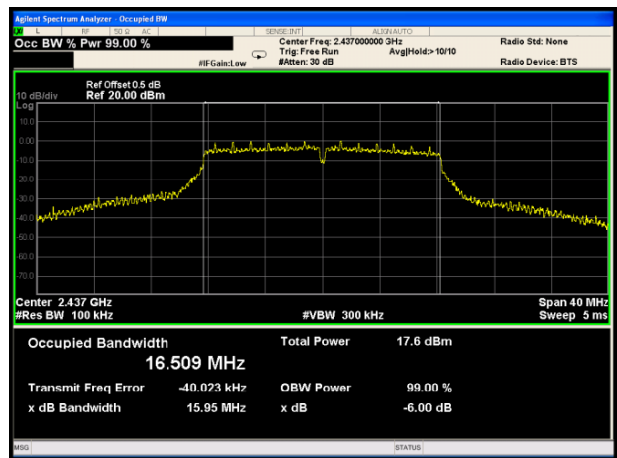
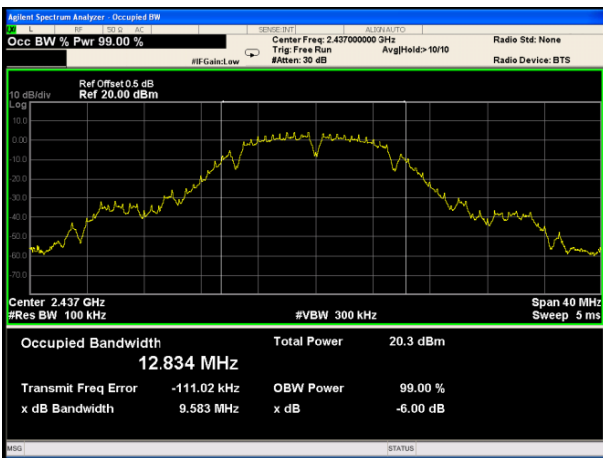

Middle channel

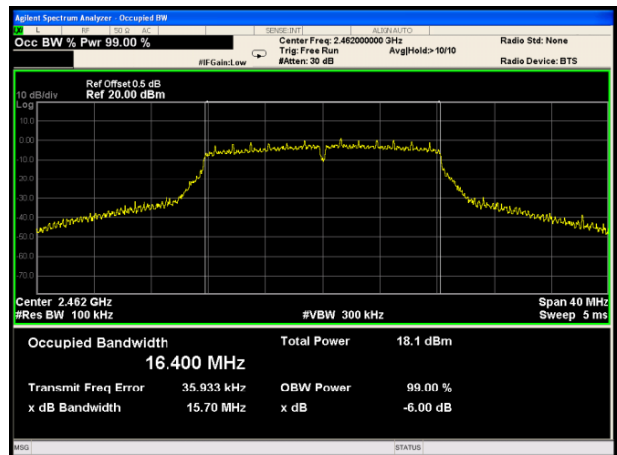
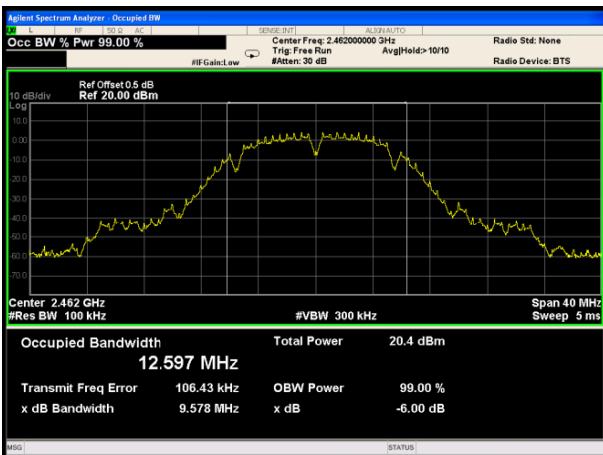

Highest channel

Power Spectral Density

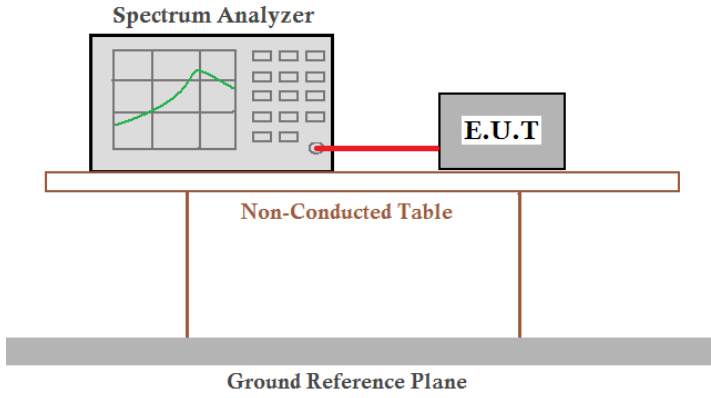
Test Requirement:	FCC Part15 C Section 15.247 (e)
Test Method:	KDB558074 D01 DTS Meas Guidance v05or02
Limit:	8dBm/3kHz
Test setup:	 <p>The diagram illustrates the test setup. A Spectrum Analyzer is connected to an E.U.T. (Equipment Under Test) via a red cable. Both are placed on a Non-Conducted Table, which is supported by a Ground Reference Plane.</p>
Test Instruments:	Refer to section 6.0 for details
Test mode:	Refer to section 5.2 for details
Test results:	Pass

Measurement Data

Test CH	Power Spectral Density (dBm/3kHz)		Limit (dBm/3kHz)	Result
	802.11b	802.11g		
Lowest	-8.87	-13.95	8.00	Pass
Middle	-8.85	-13.21		
Highest	-6.38	-13.08		

Test plot as follows:

802.11b	802.11g
---------	---------

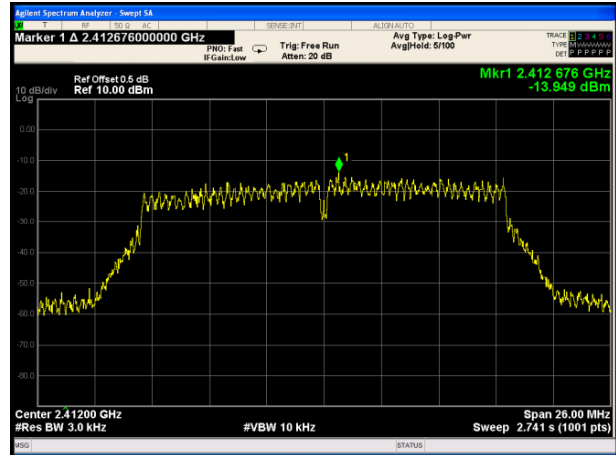
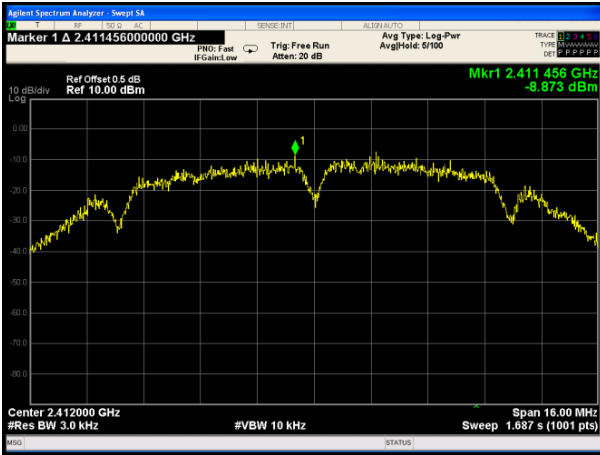

Lowest channel

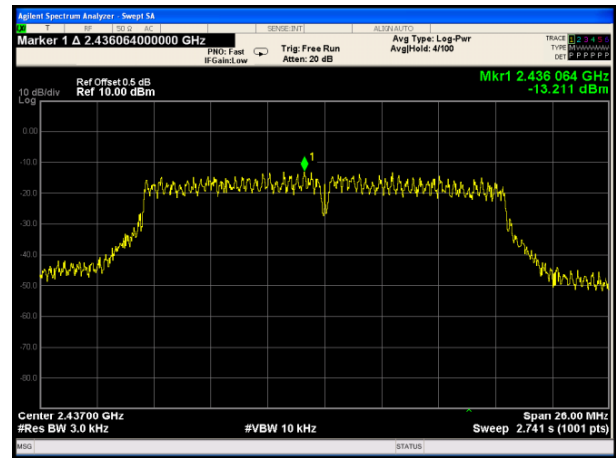
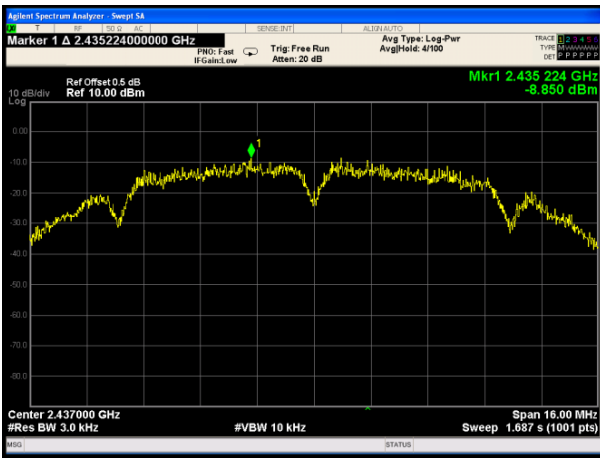

Middle channel

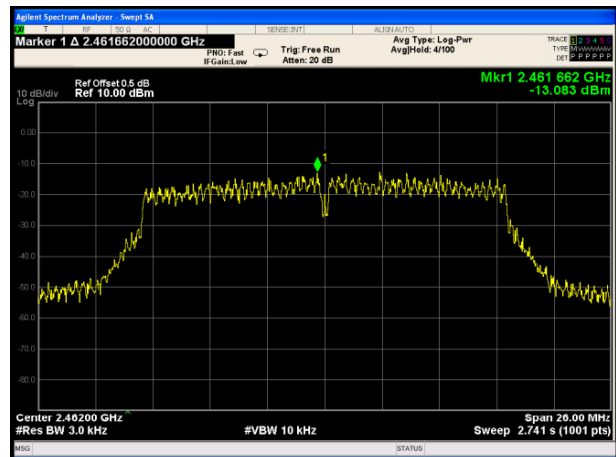
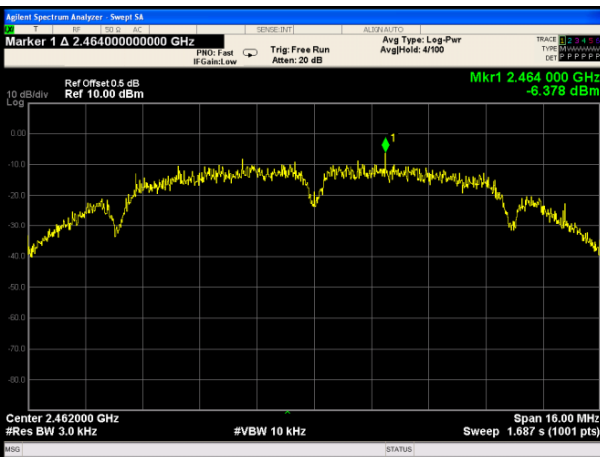

Highest channel

7.5 Band edges

7.5.1 Conducted Emission Method

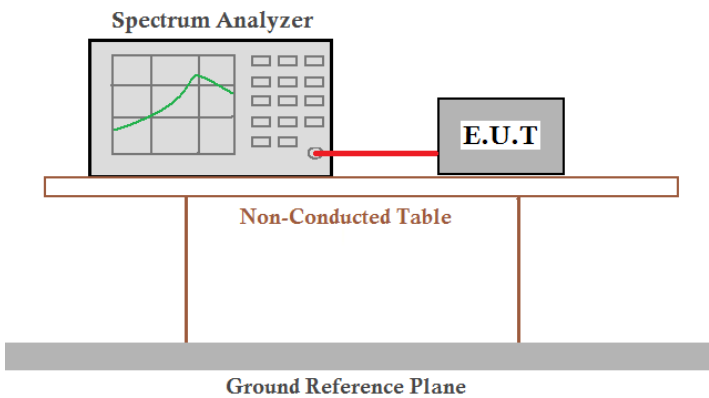
Test Requirement:	FCC Part15 C Section 15.247 (d)
Test Method:	KDB558074 D01 DTS Meas Guidance v05or02
Limit:	In any 100 kHz bandwidth outside the frequency band in which the spread spectrum intentional radiator is operating, the radio frequency power that is produced by the intentional radiator shall be at least 20 dB below that in the 100 kHz bandwidth within the band that contains the highest level of the desired power, based on either an RF conducted or a radiated measurement.
Test setup:	 <p>The diagram illustrates the test setup. A Spectrum Analyzer is connected to an E.U.T. (Equipment Under Test) via a red cable. Both are placed on a Non-Conducted Table, which is supported by two legs. Below the table is a Ground Reference Plane.</p>
Test Instruments:	Refer to section 6.0 for details
Test mode:	Refer to section 5.2 for details
Test results:	Pass

Test plot as follows:

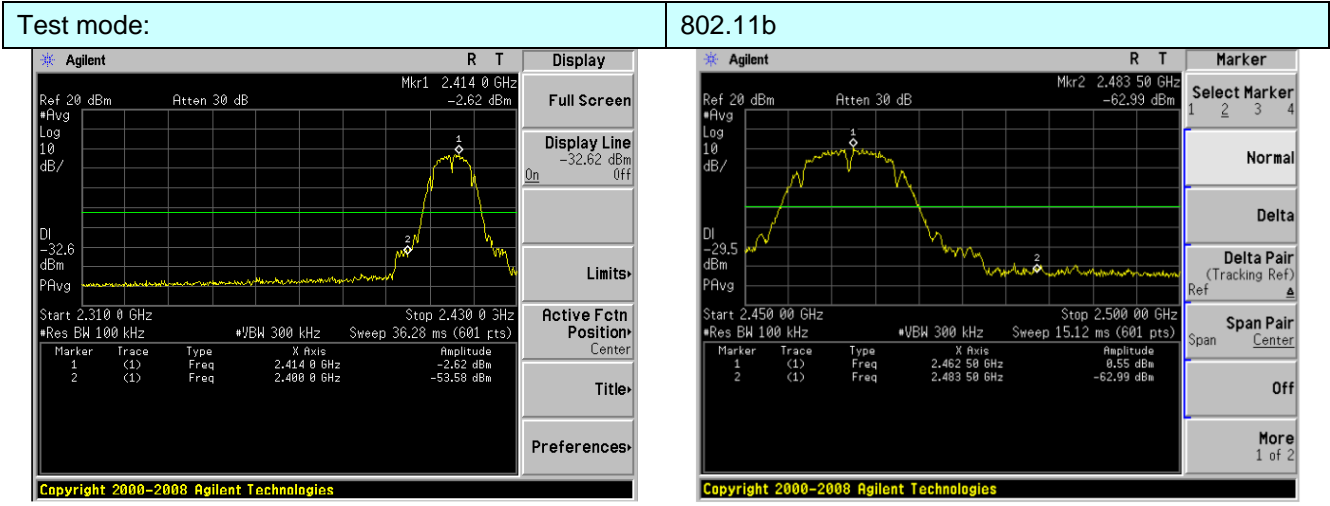

Lowest channel

Highest channel

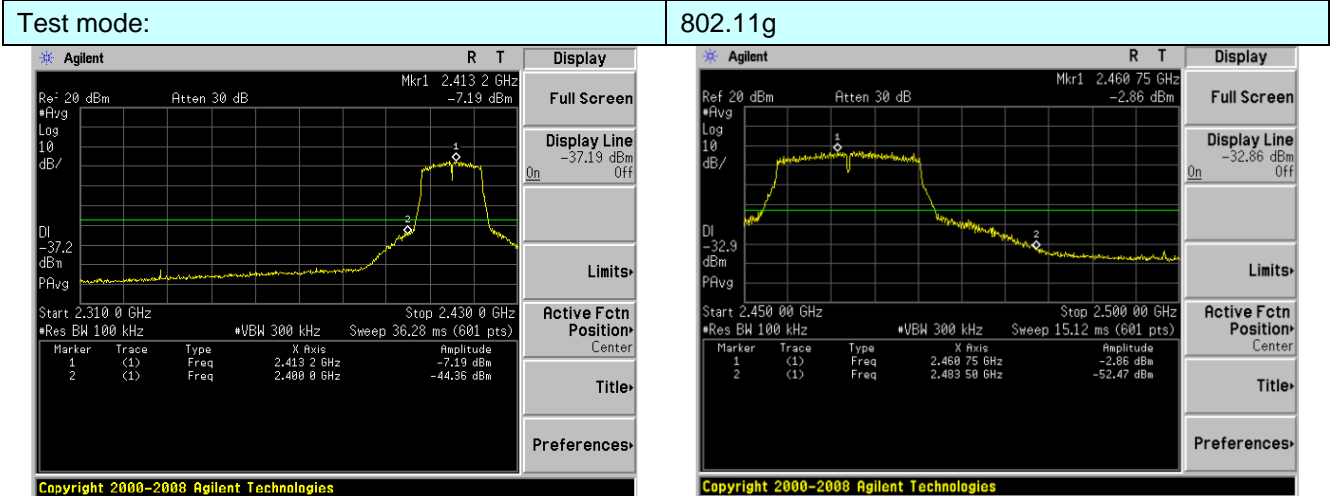

Lowest channel

Highest channel

7.5.2 Radiated Emission Method

Test Requirement:	FCC Part15 C Section 15.209 and 15.205				
Test Method:	ANSI C63.10: 2013				
Test Frequency Range:	All of the restrict bands were tested, only the worst band's (2310MHz to 2500MHz) data was showed.				
Test site:	Measurement Distance: 3m				
Receiver setup:	Frequency	Detector	RBW	VBW	Value
	Above 1GHz	Peak	1MHz	3MHz	Peak
		Average	1MHz	3MHz	Average
Limit:	Frequency		Limit (dBuV/m @3m)		Value
	Above 1GHz		54.00		Average
			74.00		Peak
Test setup:					
Test Procedure:	<ol style="list-style-type: none"> 1. The EUT was placed on the top of a rotating table 1.5 meters above the ground at a 3 meter camber. The table was rotated 360 degrees to determine the position of the highest radiation. 2. The EUT was set 3 meters away from the interference-receiving antenna, which was mounted on the top of a variable-height antenna tower. 3. The antenna height is varied from one meter to four meters above the ground to determine the maximum value of the field strength. Both horizontal and vertical polarizations of the antenna are set to make the measurement. 4. For each suspected emission, the EUT was arranged to its worst case and then the antenna was tuned to heights from 1 meter to 4 meters and the rota table was turned from 0 degrees to 360 degrees to find the maximum reading. 5. The test-receiver system was set to Peak Detect Function and Specified Bandwidth with Maximum Hold Mode. 6. If the emission level of the EUT in peak mode was 10dB lower than the limit specified, then testing could be stopped and the peak values of the EUT would be reported. Otherwise the emissions that did not have 10dB margin would be re-tested one by one using peak, quasi-peak or average method as specified and then reported in a data sheet. 7. The radiation measurements are performed in X, Y, Z axis positioning. And found the Y axis positioning which it is worse case, only the test worst case mode is recorded in the report. 				
Test Instruments:	Refer to section 6.0 for details				
Test mode:	Refer to section 5.2 for details				
Test results:	Pass				

Measurement data:

All antennas have test, only the worst case ANT 1 report.

Test mode:	802.11b	Test channel:	Lowest
------------	---------	---------------	--------

Peak value:

Frequency (MHz)	Read Level (dBuV)	Antenna Factor (dB/m)	Cable Loss (dB)	Preamp Factor (dB)	Level (dBuV/m)	Limit Line (dBuV/m)	Over Limit (dB)	Polarization
2310.00	51.08	27.59	5.38	30.18	54.44	74.00	-19.56	Horizontal
2390.00	51.58	27.58	5.39	30.18	54.94	74.00	-19.06	Horizontal
2310.00	50.76	27.59	5.38	30.18	54.11	74.00	-19.89	Vertical
2390.00	49.91	27.58	5.39	30.18	53.26	74.00	-20.74	Vertical

Average value:

Frequency (MHz)	Read Level (dBuV)	Antenna Factor (dB/m)	Cable Loss (dB)	Preamp Factor (dB)	Level (dBuV/m)	Limit Line (dBuV/m)	Over Limit (dB)	Polarization
2310.00	36.95	27.59	5.38	30.18	40.15	54.00	-13.85	Horizontal
2390.00	40.29	27.58	5.39	30.18	43.53	54.00	-10.47	Horizontal
2310.00	36.64	27.59	5.38	30.18	39.84	54.00	-14.16	Vertical
2390.00	35.86	27.58	5.39	30.18	39.05	54.00	-14.95	Vertical

Test mode:	802.11b	Test channel:	Highest
------------	---------	---------------	---------

Peak value:

Frequency (MHz)	Read Level (dBuV)	Antenna Factor (dB/m)	Cable Loss (dB)	Preamp Factor (dB)	Level (dBuV/m)	Limit Line (dBuV/m)	Over Limit (dB)	Polarization
2483.50	50.76	27.53	5.47	29.93	54.39	74.00	-19.61	Horizontal
2500.00	51.97	27.55	5.49	29.93	55.66	74.00	-18.34	Horizontal
2483.50	51.17	27.53	5.47	29.93	54.81	74.00	-19.19	Vertical
2500.00	50.80	27.55	5.49	29.93	54.47	74.00	-19.53	Vertical

Average value:

Frequency (MHz)	Read Level (dBuV)	Antenna Factor (dB/m)	Cable Loss (dB)	Preamp Factor (dB)	Level (dBuV/m)	Limit Line (dBuV/m)	Over Limit (dB)	Polarization
2483.50	37.83	27.53	5.47	29.93	41.32	54.00	-12.68	Horizontal
2500.00	40.40	27.55	5.49	29.93	43.96	54.00	-10.04	Horizontal
2483.50	38.21	27.53	5.47	29.93	41.70	54.00	-12.30	Vertical
2500.00	36.77	27.55	5.49	29.93	40.29	54.00	-13.71	Vertical

Test mode:	802.11g	Test channel:	Lowest
------------	---------	---------------	--------

Peak value:

Frequency (MHz)	Read Level (dBuV)	Antenna Factor (dB/m)	Cable Loss (dB)	Preamp Factor (dB)	Level (dBuV/m)	Limit Line (dBuV/m)	Over Limit (dB)	Polarization
2310.00	50.48	27.59	5.38	30.18	53.27	74.00	-20.73	Horizontal
2390.00	51.90	27.58	5.39	30.18	54.69	74.00	-19.31	Horizontal
2310.00	50.99	27.59	5.38	30.18	53.78	74.00	-20.22	Vertical
2390.00	49.77	27.58	5.39	30.18	52.56	74.00	-21.44	Vertical

Average value:

Frequency (MHz)	Read Level (dBuV)	Antenna Factor (dB/m)	Cable Loss (dB)	Preamp Factor (dB)	Level (dBuV/m)	Limit Line (dBuV/m)	Over Limit (dB)	Polarization
2310.00	36.83	27.59	5.38	30.18	39.62	54.00	-14.38	Horizontal
2390.00	39.72	27.58	5.39	30.18	42.51	54.00	-11.49	Horizontal
2310.00	36.84	27.59	5.38	30.18	39.63	54.00	-14.37	Vertical
2390.00	36.37	27.58	5.39	30.18	39.16	54.00	-14.84	Vertical

Test mode:	802.11g	Test channel:	Highest
------------	---------	---------------	---------

Peak value:

Frequency (MHz)	Read Level (dBuV)	Antenna Factor (dB/m)	Cable Loss (dB)	Preamp Factor (dB)	Level (dBuV/m)	Limit Line (dBuV/m)	Over Limit (dB)	Polarization
2483.50	50.70	27.53	5.47	29.93	53.77	74.00	-20.23	Horizontal
2500.00	51.58	27.55	5.49	29.93	54.69	74.00	-19.31	Horizontal
2483.50	50.99	27.53	5.47	29.93	54.06	74.00	-19.94	Vertical
2500.00	51.17	27.55	5.49	29.93	54.28	74.00	-19.72	Vertical

Average value:

Frequency (MHz)	Read Level (dBuV)	Antenna Factor (dB/m)	Cable Loss (dB)	Preamp Factor (dB)	Level (dBuV/m)	Limit Line (dBuV/m)	Over Limit (dB)	Polarization
2483.50	37.94	27.53	5.47	29.93	41.01	54.00	-12.99	Horizontal
2500.00	40.10	27.55	5.49	29.93	43.21	54.00	-10.79	Horizontal
2483.50	38.05	27.53	5.47	29.93	41.12	54.00	-12.88	Vertical
2500.00	36.85	27.55	5.49	29.93	39.96	54.00	-14.04	Vertical

Remarks:

1. Only the worst case Main Antenna test data.
2. The pre-test were performed on lowest, middle and highest frequencies, only the worst case's (lowest and highest frequencies) data was showed.
3. Final Level = Receiver Read level + Antenna Factor + Cable Loss – Pre-amplifier Factor
The emission levels of other frequencies are very lower than the limit and not show in test report.

7.6 Spurious Emission

7.6.1 Conducted Emission Method

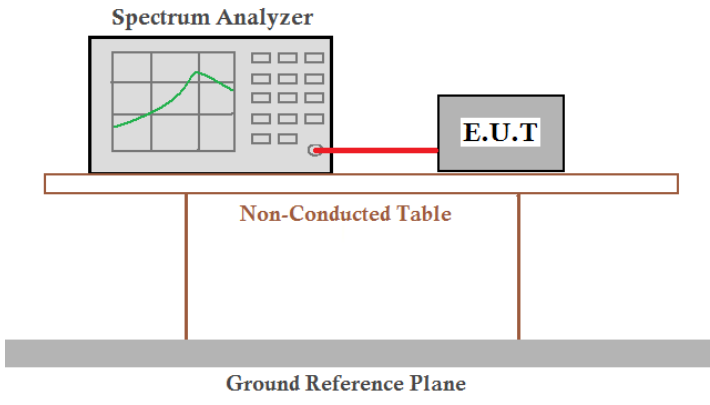
Test Requirement:	FCC Part15 C Section 15.247 (d)
Test Method:	KDB558074 D01 DTS Meas Guidance v05or02
Limit:	In any 100 kHz bandwidth outside the frequency band in which the spread spectrum intentional radiator is operating, the radio frequency power that is produced by the intentional radiator shall be at least 20 dB below that in the 100 kHz bandwidth within the band that contains the highest level of the desired power, based on either an RF conducted or a radiated measurement.
Test setup:	 <p>The diagram illustrates the test setup. A Spectrum Analyzer is connected to an E.U.T. (Equipment Under Test) via a red cable. Both are placed on a Non-Conducted Table, which is supported by two vertical legs. Below the table is a Ground Reference Plane.</p>
Test Instruments:	Refer to section 6.0 for details
Test mode:	Refer to section 5.2 for details
Test results:	<p>Pass</p> <p>we pretest all mode, the worst mode was 802.11b, and the data only show the worst mode data.</p>

Test plot as follows:

802.11b

Lowest channel

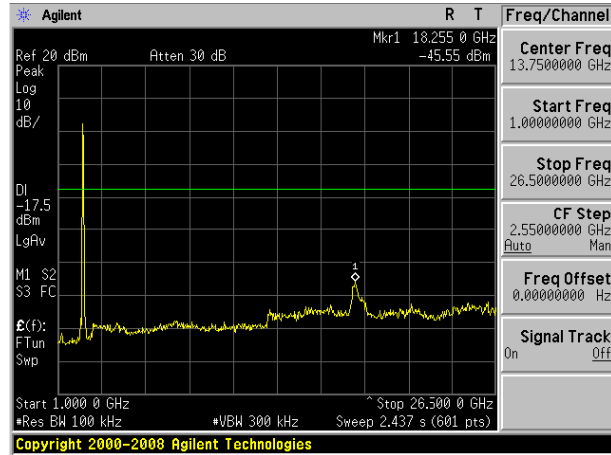
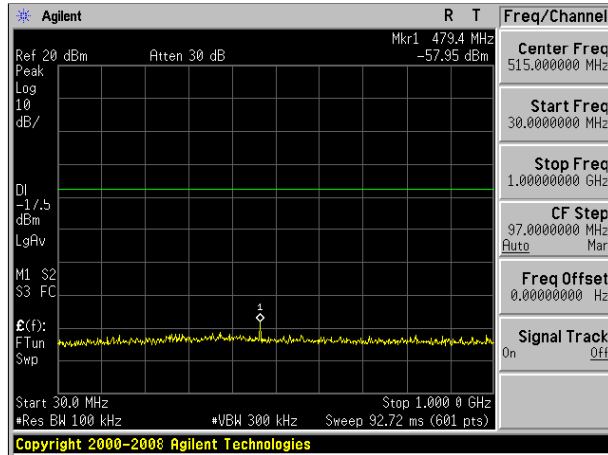

30MHz~25GHz

Middle channel

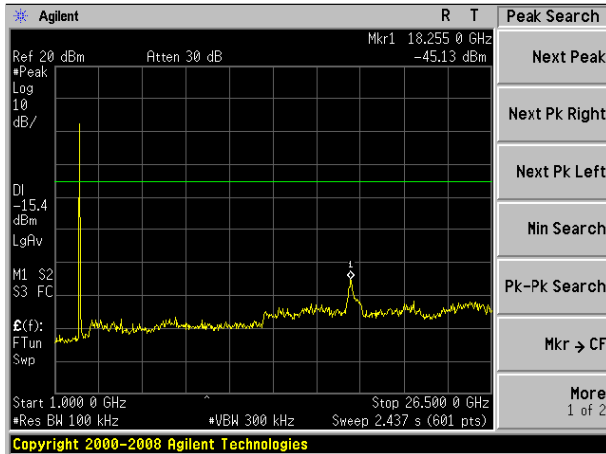
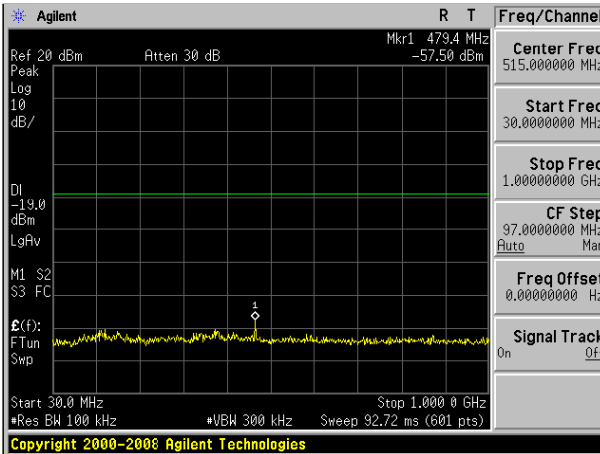

30MHz~25GHz

Highest channel

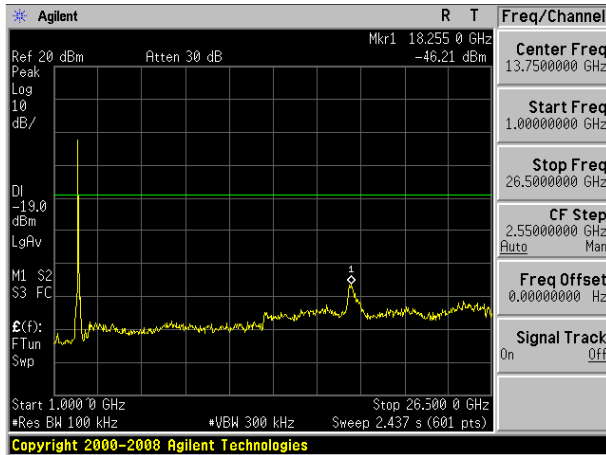
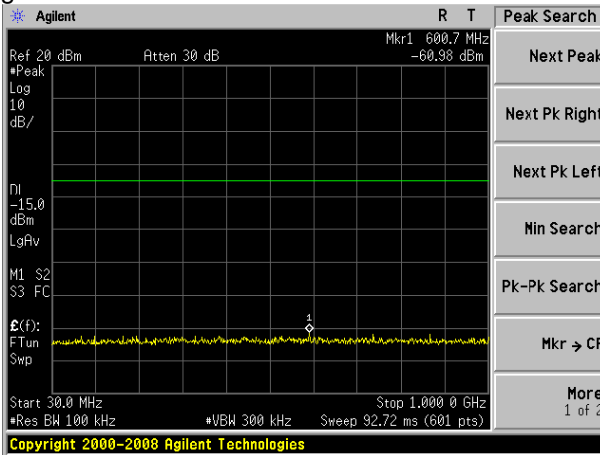

30MHz~25GHz

7.6.2 Radiated Emission Method

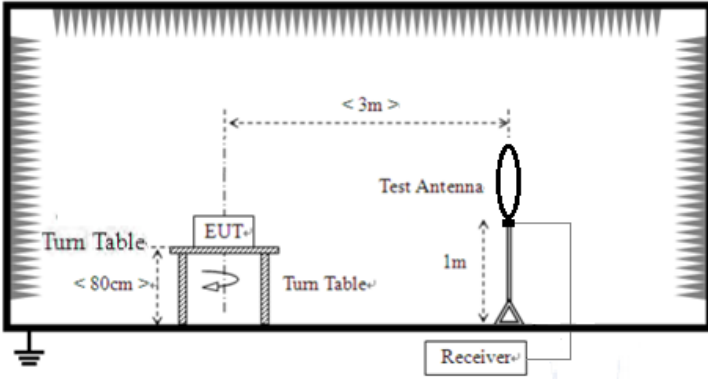
Test Requirement:	FCC Part15 C Section 15.209				
Test Method:	ANSI C63.10: 2013				
Test Frequency Range:	9kHz to 25GHz				
Test site:	Measurement Distance: 3m				
Receiver setup:	Frequency	Detector	RBW	VBW	Value
	9KHz-150KHz	Quasi-peak	200Hz	600Hz	Quasi-peak
	150KHz-30MHz	Quasi-peak	9KHz	30KHz	Quasi-peak
	30MHz-1GHz	Quasi-peak	100KHz	300KHz	Quasi-peak
	Above 1GHz	Peak	1MHz	3MHz	Peak
Peak		1MHz	10Hz	Average	
Limit:	Frequency	Limit (uV/m)	Value	Measurement Distance	
	0.009MHz-0.490MHz	2400/F(KHz)	QP	300m	
	0.490MHz-1.705MHz	24000/F(KHz)	QP	300m	
	1.705MHz-30MHz	30	QP	30m	
	30MHz-88MHz	100	QP	3m	
	88MHz-216MHz	150	QP		
	216MHz-960MHz	200	QP		
	960MHz-1GHz	500	QP		
	Above 1GHz	500	Average		
		5000	Peak		
Test setup:	For radiated emissions from 9kHz to 30MHz				
	 <p>The diagram illustrates the test setup for radiated emissions from 9kHz to 30MHz. It shows an Equipment Under Test (EUT) placed on a turn table. A test antenna is positioned 3m away from the EUT. The antenna is 1m high. The turn table is 80cm high. A receiver is connected to the antenna. The setup is shown within a shielded enclosure.</p>				
For radiated emissions from 30MHz to 1GHz					

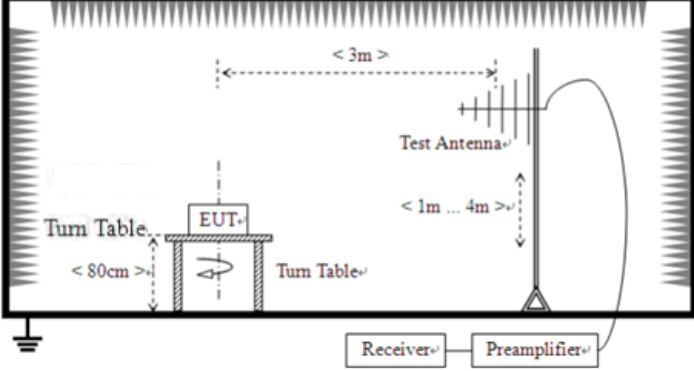
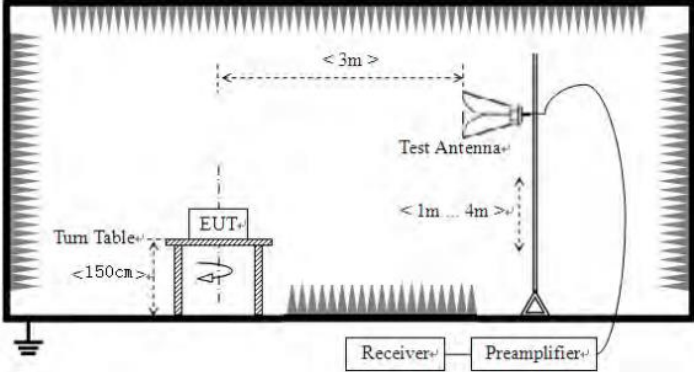
	 <p>For radiated emissions above 1GHz</p> 
<p>Test Procedure:</p>	<ol style="list-style-type: none"> 1. The EUT was placed on the top of a rotating table (0.8m for below 1G and 1.5m for above 1G) above the ground at a 3 meter camber. The table was rotated 360 degrees to determine the position of the highest radiation. 2. The EUT was set 3 meters away from the interference-receiving antenna, which was mounted on the top of a variable-height antenna tower. 3. The antenna height is varied from one meter to four meters above the ground to determine the maximum value of the field strength. Both horizontal and vertical polarizations of the antenna are set to make the measurement. 4. For each suspected emission, the EUT was arranged to its worst case and then the antenna was tuned to heights from 1 meter to 4 meters and the rota table was turned from 0 degrees to 360 degrees to find the maximum reading. 5. The test-receiver system was set to Peak Detect Function and Specified Bandwidth with Maximum Hold Mode. 6. If the emission level of the EUT in peak mode was 10dB lower than the limit specified, then testing could be stopped and the peak values of the EUT would be reported. Otherwise the emissions that did not have 10dB margin would be re-tested one by one using peak, quasi-peak or average method as specified and then reported in a data sheet.
<p>Test Instruments:</p>	<p>Refer to section 6.0 for details</p>

Test mode:	Refer to section 5.2 for details					
Test voltage:	AC120V 60Hz					
Test environment:	Temp.:	25 °C	Humid.:	52%	Press.:	1012mbar
Test voltage:	AC 120V, 60Hz					
Test results:	Pass					

Remarks:

1. *Only the worst case Main Antenna test data.*
2. *Pre-scan all kind of the place mode (X-axis, Y-axis, Z-axis), and found the Y-axis which it is worse case.*

Measurement data:

■ **9kHz~30MHz**

The emission from 9 kHz to 30MHz was pre-tested and found the result was 20dB lower than the limit, and according to 15.31(o) & RSS-Gen 6.13, the test result no need to reported.

■ Below 1GHz

Pre-scan all test modes, found worst case at 802.11b 2462MHz, and so only show the test result of 802.11b 2462MHz

Horizontal:

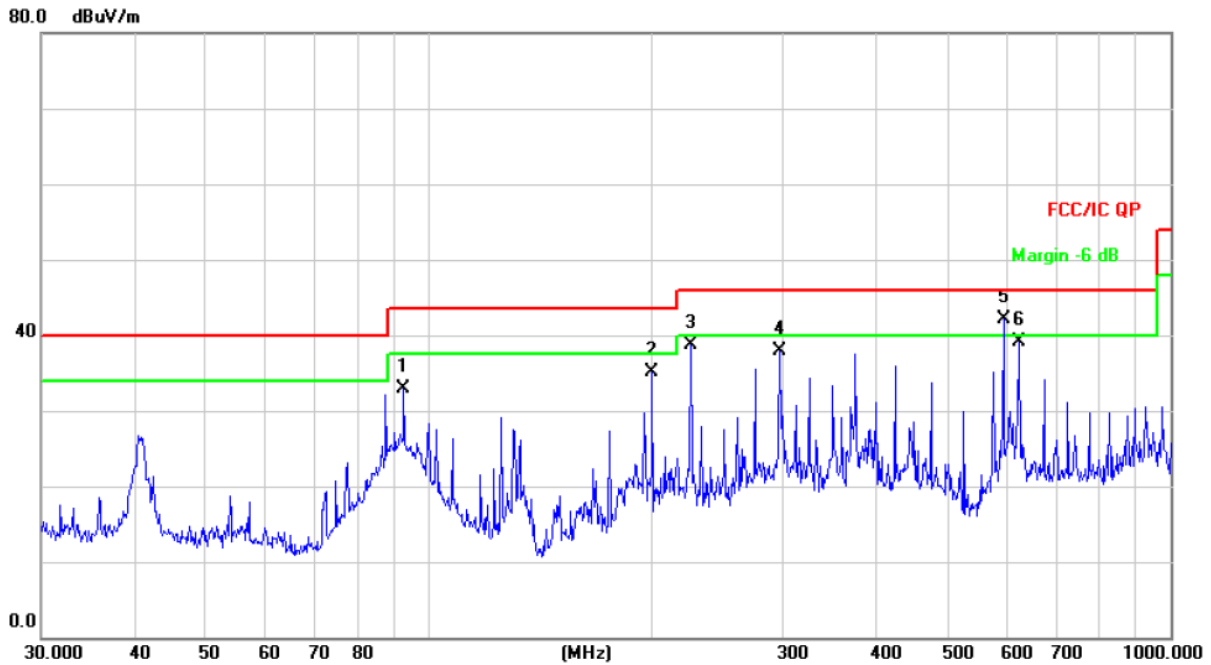

No.	Mk.	Freq. MHz	Reading Level dBuV	Correct Factor dB/m	Measure- ment dBuV/m	Limit dBuV/m	Over dB	Detector
1		92.4624	50.16	-17.26	32.90	43.50	-10.60	QP
2		199.9856	51.37	-16.20	35.17	43.50	-8.33	QP
3		225.3080	54.10	-15.32	38.78	46.00	-7.22	QP
4		297.2241	50.59	-12.66	37.93	46.00	-8.07	QP
5	*	595.1329	47.91	-5.83	42.08	46.00	-3.92	QP
6		625.0780	44.67	-5.52	39.15	46.00	-6.85	QP

Vertical:

80.0 dBuV/m

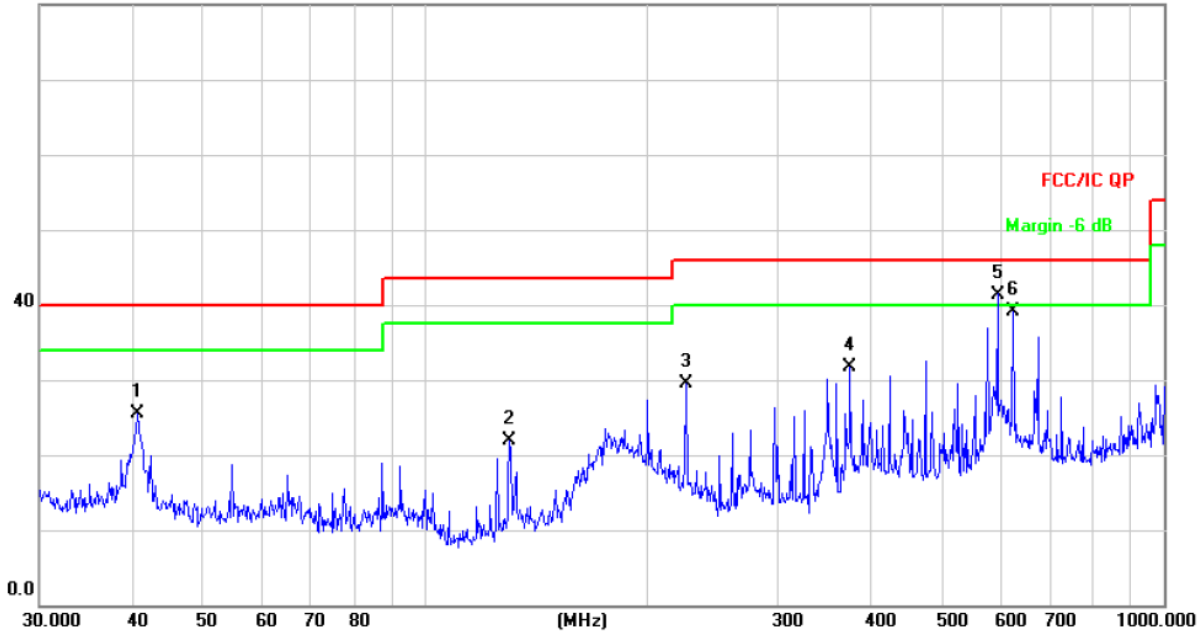

No.	Mk.	Freq. MHz	Reading Level dBuV	Correct Factor dB/m	Measure- ment dBuV/m	Limit dBuV/m	Over dB	Detector
1		40.7016	34.43	-8.94	25.49	40.00	-14.51	QP
2		129.9226	35.94	-14.11	21.83	43.50	-21.67	QP
3		225.3080	44.80	-15.32	29.48	46.00	-16.52	QP
4		375.9385	42.44	-10.77	31.67	46.00	-14.33	QP
5	*	595.1329	47.23	-5.83	41.40	46.00	-4.60	QP
6		625.0780	44.65	-5.52	39.13	46.00	-6.87	QP

■ 1-25GHz

Test mode:	802.11b	Test channel:	Lowest
------------	---------	---------------	--------

Peak value:

Frequency (MHz)	Read Level (dBuV)	Antenna Factor (dB/m)	Cable Loss (dB)	Preamp Factor (dB)	Level (dBuV/m)	Limit Line (dBuV/m)	Over Limit (dB)	polarization
4824	53.64	31.78	8.60	32.09	61.93	74.00	-12.07	Vertical
7236	46.63	38.14	11.65	32.00	64.42	74.00	-9.58	Vertical
9648	45.05	38.45	14.14	31.62	66.02	74.00	-7.98	Vertical
12060	*							Vertical
14472	*							Vertical
16884	*							Vertical
4824	54.14	29.65	8.60	32.09	60.30	74.00	-13.70	Horizontal
7236	47.10	35.62	11.65	32.00	62.37	74.00	-11.63	Horizontal
9648	36.82	42.58	14.14	31.62	61.92	74.00	-12.08	Horizontal
12060	*							Horizontal
14472	*							Horizontal
16884	*							Horizontal

Average value:

Frequency (MHz)	Read Level (dBuV)	Antenna Factor (dB/m)	Cable Loss (dB)	Preamp Factor (dB)	Level (dBuV/m)	Limit Line (dBuV/m)	Over Limit (dB)	polarization
4824	39.30	31.78	8.60	32.09	47.59	54.00	-6.41	Vertical
7236	32.00	36.15	11.65	32.00	47.80	54.00	-6.20	Vertical
9648	29.22	37.95	14.14	31.62	49.69	54.00	-4.31	Vertical
12060	*							Vertical
14472	*							Vertical
16884	*							Vertical
4824	36.43	31.78	8.60	32.09	44.72	54.00	-9.28	Horizontal
7236	31.80	36.15	11.65	32.00	47.60	54.00	-6.40	Horizontal
9648	26.92	37.95	14.14	31.62	47.39	54.00	-6.61	Horizontal
12060	*							Horizontal
14472	*							Horizontal
16884	*							Horizontal

Remark:

1. Final Level = Receiver Read level + Antenna Factor + Cable Loss – Preamplifier Factor
2. The emission levels of other frequencies are very lower than the limit and not show in test report.
3. “*”, means this data is the too weak instrument of signal is unable to test.

Test mode:	802.11b	Test channel:	Middle
------------	---------	---------------	--------

Peak value:

Frequency (MHz)	Read Level (dBuV)	Antenna Factor (dB/m)	Cable Loss (dB)	Preamp Factor (dB)	Level (dBuV/m)	Limit Line (dBuV/m)	Over Limit (dB)	polarization
4874	54.53	31.85	8.67	32.12	62.93	74.00	-11.07	Vertical
7311	43.84	36.37	11.72	31.89	60.04	74.00	-13.96	Vertical
9748	46.43	38.35	14.25	31.62	67.41	74.00	-6.59	Vertical
12185	*							Vertical
14622	*							Vertical
17059	*							Vertical
4874	52.91	31.85	8.67	32.12	61.31	74.00	-12.69	Horizontal
7311	46.44	36.37	11.72	31.89	62.64	74.00	-11.36	Horizontal
9748	37.84	38.35	14.25	31.62	58.82	74.00	-15.18	Horizontal
12185	*							Horizontal
14622	*							Horizontal
17059	*							Horizontal

Average value:

Frequency (MHz)	Read Level (dBuV)	Antenna Factor (dB/m)	Cable Loss (dB)	Preamp Factor (dB)	Level (dBuV/m)	Limit Line (dBuV/m)	Over Limit (dB)	polarization
4874	38.89	31.85	8.67	32.12	47.29	54.00	-6.71	Vertical
7311	33.03	36.37	11.72	31.89	49.23	54.00	-4.77	Vertical
9748	28.53	38.35	14.25	31.62	49.51	54.00	-4.49	Vertical
12185	*							Vertical
14622	*							Vertical
17059	*							Vertical
4874	35.17	31.85	8.67	32.12	43.57	54.00	-10.43	Horizontal
7311	31.80	36.37	11.72	31.89	48.00	54.00	-6.00	Horizontal
9748	24.09	38.35	14.25	31.62	45.07	54.00	-8.93	Horizontal
12185	*							Horizontal
14622	*							Horizontal
17059	*							Horizontal

Remark:

1. Final Level = Receiver Read level + Antenna Factor + Cable Loss – Pre-amplifier Factor
2. The emission levels of other frequencies are very lower than the limit and not show in test report.
3. “*”, means this data is the too weak instrument of signal is unable to test.

Test mode:	802.11b	Test channel:	Highest
------------	---------	---------------	---------

Peak value:

Frequency (MHz)	Read Level (dBuV)	Antenna Factor (dB/m)	Cable Loss (dB)	Preamp Factor (dB)	Level (dBuV/m)	Limit Line (dBuV/m)	Over Limit (dB)	polarization
4924	54.14	31.93	8.73	32.16	62.64	74.00	-11.36	Vertical
7386	45.05	36.59	11.79	31.78	61.65	74.00	-12.35	Vertical
9848	42.22	38.81	14.38	31.88	63.53	74.00	-10.47	Vertical
12310	*							Vertical
14772	*							Vertical
17234	*							Vertical
4924	54.34	31.93	8.73	32.16	62.84	74.00	-11.16	Horizontal
7386	46.96	36.59	11.79	31.78	63.56	74.00	-10.44	Horizontal
9848	36.44	38.81	14.38	31.88	57.75	74.00	-16.25	Horizontal
12310	*							Horizontal
14772	*							Horizontal
17234	*							Horizontal

Average value:

Frequency (MHz)	Read Level (dBuV)	Antenna Factor (dB/m)	Cable Loss (dB)	Preamp Factor (dB)	Level (dBuV/m)	Limit Line (dBuV/m)	Over Limit (dB)	polarization
4924	37.15	31.93	8.73	32.16	45.65	54.00	-8.35	Vertical
7386	29.79	36.59	11.79	31.78	46.39	54.00	-7.61	Vertical
9848	24.17	38.81	14.38	31.88	45.48	54.00	-8.52	Vertical
12310	*							Vertical
14772	*							Vertical
17234	*							Vertical
4924	35.24	31.93	8.73	32.16	43.74	54.00	-10.26	Horizontal
7386	29.72	36.59	11.79	31.78	46.32	54.00	-7.68	Horizontal
9848	25.67	38.81	14.38	31.88	46.98	54.00	-7.02	Horizontal
12310	*							Horizontal
14772	*							Horizontal
17234	*							Horizontal

Remark:

1. Final Level = Receiver Read level + Antenna Factor + Cable Loss – Pre-amplifier Factor
2. The emission levels of other frequencies are very lower than the limit and not show in test report.
3. “*”, means this data is the too weak instrument of signal is unable to test.

Test mode:	802.11g	Test channel:	lowest
------------	---------	---------------	--------

Peak value:

Frequency (MHz)	Read Level (dBuV)	Antenna Factor (dB/m)	Cable Loss (dB)	Preamp Factor (dB)	Level (dBuV/m)	Limit Line (dBuV/m)	Over Limit (dB)	polarization
4824	52.95	31.78	8.60	32.09	61.24	74.00	-12.76	Vertical
7236	46.21	38.14	11.65	32.00	64.00	74.00	-10.00	Vertical
9648	43.82	38.45	14.14	31.62	64.79	74.00	-9.21	Vertical
12060	*							Vertical
14472	*							Vertical
16884	*							Vertical
4824	52.99	29.65	8.60	32.09	59.15	74.00	-14.85	Horizontal
7236	45.84	35.62	11.65	32.00	61.11	74.00	-12.89	Horizontal
9648	35.48	42.58	14.14	31.62	60.58	74.00	-13.42	Horizontal
12060	*							Horizontal
14472	*							Horizontal
16884	*							Horizontal

Average value:

Frequency (MHz)	Read Level (dBuV)	Antenna Factor (dB/m)	Cable Loss (dB)	Preamp Factor (dB)	Level (dBuV/m)	Limit Line (dBuV/m)	Over Limit (dB)	polarization
4824	38.21	31.78	8.60	32.09	46.50	54.00	-7.50	Vertical
7236	30.88	36.15	11.65	32.00	46.68	54.00	-7.32	Vertical
9648	28.23	37.95	14.14	31.62	48.70	54.00	-5.30	Vertical
12060	*							Vertical
14472	*							Vertical
16884	*							Vertical
4824	34.79	31.78	8.60	32.09	43.08	54.00	-10.92	Horizontal
7236	31.02	36.15	11.65	32.00	46.82	54.00	-7.18	Horizontal
9648	26.12	37.95	14.14	31.62	46.59	54.00	-7.41	Horizontal
12060	*							Horizontal
14472	*							Horizontal
16884	*							Horizontal

Remark:

1. Final Level = Receiver Read level + Antenna Factor + Cable Loss – Pre-amplifier Factor
2. The emission levels of other frequencies are very lower than the limit and not show in test report.
3. “*”, means this data is the too weak instrument of signal is unable to test.

Test mode:	802.11g	Test channel:	Middle
------------	---------	---------------	--------

Peak value:

Frequency (MHz)	Read Level (dBuV)	Antenna Factor (dB/m)	Cable Loss (dB)	Preamp Factor (dB)	Level (dBuV/m)	Limit Line (dBuV/m)	Over Limit (dB)	polarization
4874	54.03	31.85	8.67	32.12	62.43	74.00	-11.57	Vertical
7311	43.98	36.37	11.72	31.89	60.18	74.00	-13.82	Vertical
9748	46.33	38.35	14.25	31.62	67.31	74.00	-6.69	Vertical
12185	*							Vertical
14622	*							Vertical
17059	*							Vertical
4874	52.56	31.85	8.67	32.12	60.96	74.00	-13.04	Horizontal
7311	45.85	36.37	11.72	31.89	62.05	74.00	-11.95	Horizontal
9748	38.13	38.35	14.25	31.62	59.11	74.00	-14.89	Horizontal
12185	*							Horizontal
14622	*							Horizontal
17059	*							Horizontal

Average value:

Frequency (MHz)	Read Level (dBuV)	Antenna Factor (dB/m)	Cable Loss (dB)	Preamp Factor (dB)	Level (dBuV/m)	Limit Line (dBuV/m)	Over Limit (dB)	polarization
4874	38.93	31.85	8.67	32.12	47.33	54.00	-6.67	Vertical
7311	32.79	36.37	11.72	31.89	48.99	54.00	-5.01	Vertical
9748	27.77	38.35	14.25	31.62	48.75	54.00	-5.25	Vertical
12185	*							Vertical
14622	*							Vertical
17059	*							Vertical
4874	34.97	31.85	8.67	32.12	43.37	54.00	-10.63	Horizontal
7311	31.76	36.37	11.72	31.89	47.96	54.00	-6.04	Horizontal
9748	24.58	38.35	14.25	31.62	45.56	54.00	-8.44	Horizontal
12185	*							Horizontal
14622	*							Horizontal
17059	*							Horizontal

Remark:

1. Final Level = Receiver Read level + Antenna Factor + Cable Loss – Pre-amplifier Factor
2. The emission levels of other frequencies are very lower than the limit and not show in test report.
3. “*”, means this data is the too weak instrument of signal is unable to test.

Test mode:	802.11g	Test channel:	Highest
------------	---------	---------------	---------

Peak value:

Frequency (MHz)	Read Level (dBuV)	Antenna Factor (dB/m)	Cable Loss (dB)	Preamp Factor (dB)	Level (dBuV/m)	Limit Line (dBuV/m)	Over Limit (dB)	polarization
4924	54.03	31.93	8.73	32.16	62.53	74.00	-11.47	Vertical
7386	44.72	36.59	11.79	31.78	61.32	74.00	-12.68	Vertical
9848	41.84	38.81	14.38	31.88	63.15	74.00	-10.85	Vertical
12310	*							Vertical
14772	*							Vertical
17234	*							Vertical
4924	53.49	31.93	8.73	32.16	61.99	74.00	-12.01	Horizontal
7386	46.62	36.59	11.79	31.78	63.22	74.00	-10.78	Horizontal
9848	36.44	38.81	14.38	31.88	57.75	74.00	-16.25	Horizontal
12310	*							Horizontal
14772	*							Horizontal
17234	*							Horizontal

Average value:

Frequency (MHz)	Read Level (dBuV)	Antenna Factor (dB/m)	Cable Loss (dB)	Preamp Factor (dB)	Level (dBuV/m)	Limit Line (dBuV/m)	Over Limit (dB)	polarization
4924	37.00	31.93	8.73	32.16	45.50	54.00	-8.50	Vertical
7386	30.03	36.59	11.79	31.78	46.63	54.00	-7.37	Vertical
9848	23.82	38.81	14.38	31.88	45.13	54.00	-8.87	Vertical
12310	*							Vertical
14772	*							Vertical
17234	*							Vertical
4924	35.15	31.93	8.73	32.16	43.65	54.00	-10.35	Horizontal
7386	30.04	36.59	11.79	31.78	46.64	54.00	-7.36	Horizontal
9848	24.80	38.81	14.38	31.88	46.11	54.00	-7.89	Horizontal
12310	*							Horizontal
14772	*							Horizontal
17234	*							Horizontal

Remark:

1. Final Level = Receiver Read level + Antenna Factor + Cable Loss – Preamplifier Factor
2. The emission levels of other frequencies are very lower than the limit and not show in test report.
3. “*”, means this data is the too weak instrument of signal is unable to test.

8 Test Setup Photo

Reference to the **appendix I** for details.

9 EUT Constructional Details

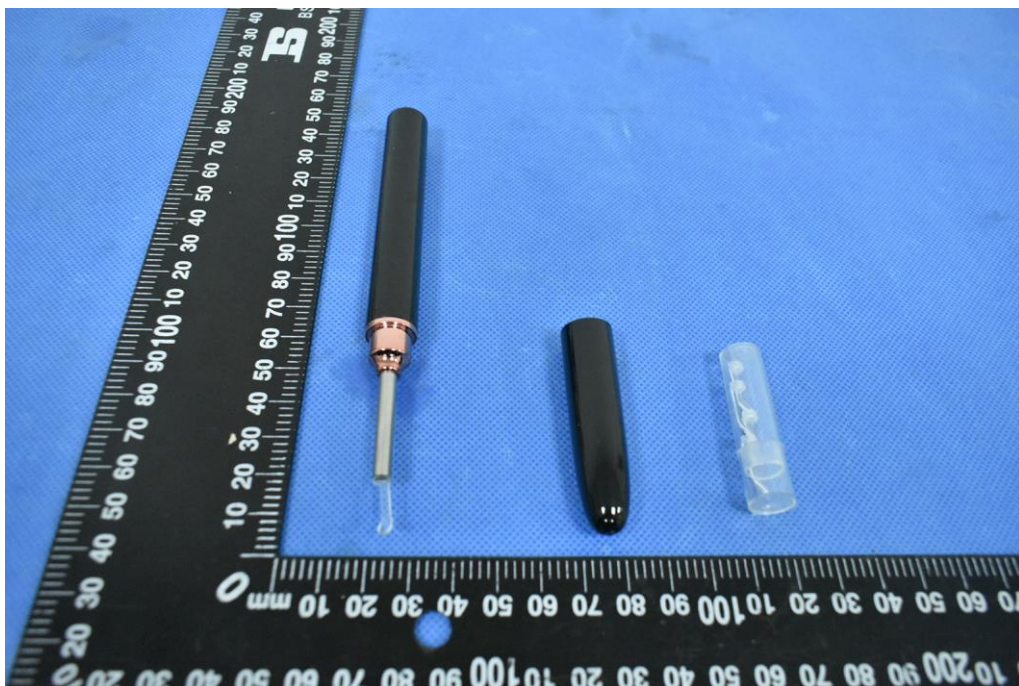

-----End-----