

# TEST REPORT

Report No.: BCTC2403182176-2E

---

Applicant: REOLINK INNOVATION LIMITED

---

Product Name: WiFi IP Camera

---

Test Model: RLC-510WA

---

Tested Date: 2024-03-07 to 2024-03-29

---

Issued Date: 2024-03-29

---

**Shenzhen BCTC Testing Co., Ltd.**



# FCC ID: 2AYHE-2402C

Product Name: WiFi IP Camera

Trademark: 

Model/Type reference: RLC-510WA  
W320,B500W

Prepared For: REOLINK INNOVATION LIMITED

Address: FLAT/RM 705 7/F FA YUEN COMMERCIAL BUILDING 75-77 FA YUEN STREET MONG KOK KL HONG KONG

Manufacturer: REOLINK INNOVATION LIMITED

Address: FLAT/RM 705 7/F FA YUEN COMMERCIAL BUILDING 75-77 FA YUEN STREET MONG KOK KL HONG KONG

Factory: Shenzhen Reolink Technology Co., Ltd.

Address: 2-4th Floor, Building 2, YuanLing Industrial Park, ShangWu, Shiyan Street, Bao'an District, Shenzhen, China

Prepared By: Shenzhen BCTC Testing Co., Ltd.

Address: 1-2/F., Building B, Pengzhou Industrial Park, No.158, Fuyuan 1st Road, Zhancheng, Fuhai Subdistrict, Bao'an District, Shenzhen, Guangdong, China

Sample Received Date: 2024-03-07

Sample tested Date: 2024-03-07 to 2024-03-29

Issue Date: 2024-03-29

Report No.: BCTC2403182176-2E

Test Standards: FCC Part15 15.407  
ANSI C63.10-2013  
KDB 662911 D01 v02r01  
KDB 789033 D02 v02r01

Test Results: PASS

Tested by:

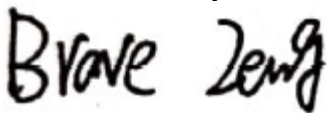

Brave Zeng/ Project Handler

Approved by:



Zero Zhou/Reviewer

The test report is effective only with both signature and specialized stamp. This result(s) shown in this report refer only to the sample(s) tested. Without written approval of Shenzhen BCTC Testing Co., Ltd, this report can't be reproduced except in full. The tested sample(s) and the sample information are provided by the client.

## Table Of Content

|   | Page |
|---|------|
| Test Report Declaration                               |      |
| 1. Version .....                                      | 5    |
| 2. Test Summary .....                                 | 6    |
| 3. Measurement Uncertainty .....                      | 7    |
| 4. Product Information And Test Setup .....           | 8    |
| 4.1 Product Information.....                          | 8    |
| 4.2 Test Setup Configuration .....                    | 9    |
| 4.3 Support Equipment .....                           | 9    |
| 4.4 Channel List .....                                | 10   |
| 4.5 Test Mode .....                                   | 11   |
| 4.6 Table Of Parameters Of Text Software Setting..... | 11   |
| 4.7 Antenna.....                                      | 11   |
| 5. Test Facility And Test Instrument Used.....        | 12   |
| 5.1 Test Facility.....                                | 12   |
| 5.2 Test Instrument Used.....                         | 12   |
| 6. Conducted Emissions.....                           | 14   |
| 6.1 Block Diagram Of Test Setup.....                  | 14   |
| 6.2 Limit .....                                       | 14   |
| 6.3 Test Procedure .....                              | 14   |
| 6.4 EUT Operating Conditions .....                    | 14   |
| 6.5 Test Result.....                                  | 15   |
| 7. Radiated Emissions.....                            | 17   |
| 7.1 Block Diagram Of Test Setup.....                  | 17   |
| 7.2 Limit .....                                       | 18   |
| 7.3 Test Procedure .....                              | 19   |
| 7.4 EUT Operating Conditions .....                    | 20   |
| 7.5 Test Result.....                                  | 20   |
| 8. Power Spectral Density Test .....                  | 47   |
| 8.1 Block Diagram Of Test Setup.....                  | 47   |
| 8.2 Limit .....                                       | 47   |
| 8.3 Test Procedure .....                              | 48   |
| 8.4 EUT Operating Conditions .....                    | 48   |
| 8.5 Test Result.....                                  | 49   |
| 9. 26dB & 6dB & 99% Emission Bandwidth .....          | 82   |
| 9.1 Block Diagram Of Test Setup.....                  | 82   |
| 9.2 Limit .....                                       | 82   |
| 9.3 Test Procedure .....                              | 82   |
| 9.4 EUT Operating Conditions .....                    | 83   |
| 9.5 Test Result.....                                  | 84   |
| 10. Maximum Conducted Output Power.....               | 146  |
| 10.1 Block Diagram Of Test Setup.....                 | 146  |
| 10.2 Limit .....                                      | 146  |
| 10.3 Test Procedure .....                             | 146  |
| 10.4 EUT Operating Conditions .....                   | 147  |

|      |                                       |     |
|------|---------------------------------------|-----|
| 10.5 | Test Result.....                      | 148 |
| 11.  | Out Of Band Emissions .....           | 152 |
| 11.1 | Block Diagram Of Test Setup.....      | 152 |
| 11.2 | Limit .....                           | 152 |
| 11.3 | Test Procedure .....                  | 152 |
| 11.4 | EUT Operating Conditions .....        | 152 |
| 11.5 | Test Result.....                      | 153 |
| 12.  | Spurious RF Conducted Emissions.....  | 176 |
| 12.1 | Block Diagram Of Test Setup.....      | 176 |
| 12.2 | Limit .....                           | 176 |
| 12.3 | Test Procedure .....                  | 176 |
| 12.4 | Test Result.....                      | 176 |
| 13.  | Frequency Stability Measurement ..... | 206 |
| 13.1 | Block Diagram Of Test Setup.....      | 206 |
| 13.2 | Limit .....                           | 206 |
| 13.3 | Test Procedure .....                  | 206 |
| 13.4 | Test Result.....                      | 207 |
| 14.  | Duty Cycle Of Test Signal .....       | 219 |
| 14.1 | Standard Requirement.....             | 219 |
| 14.2 | Formula.....                          | 219 |
| 14.3 | Test Procedure .....                  | 219 |
| 14.4 | Test Result.....                      | 220 |
| 15.  | Antenna Requirement .....             | 253 |
| 15.1 | Limit .....                           | 253 |
| 15.2 | Test Result.....                      | 253 |
| 16.  | EUT Photographs.....                  | 254 |
| 17.  | EUT Test Setup Photographs.....       | 255 |

(Note: N/A Means Not Applicable)

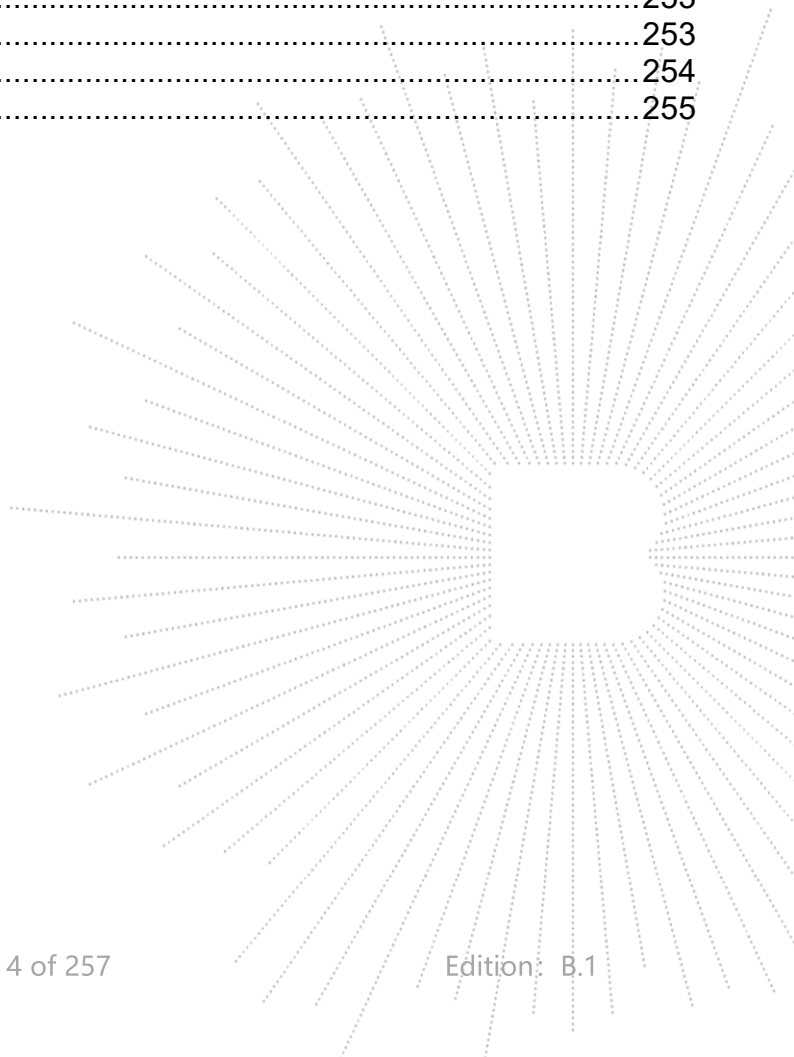

**1. Version**

| <b>Report No.</b> | <b>Issue Date</b> | <b>Description</b> | <b>Approved</b> |
|-------------------|-------------------|--------------------|-----------------|
| BCTC2403182176-2E | 2024-03-29        | Original           | Valid           |
|                   |                   |                    |                 |

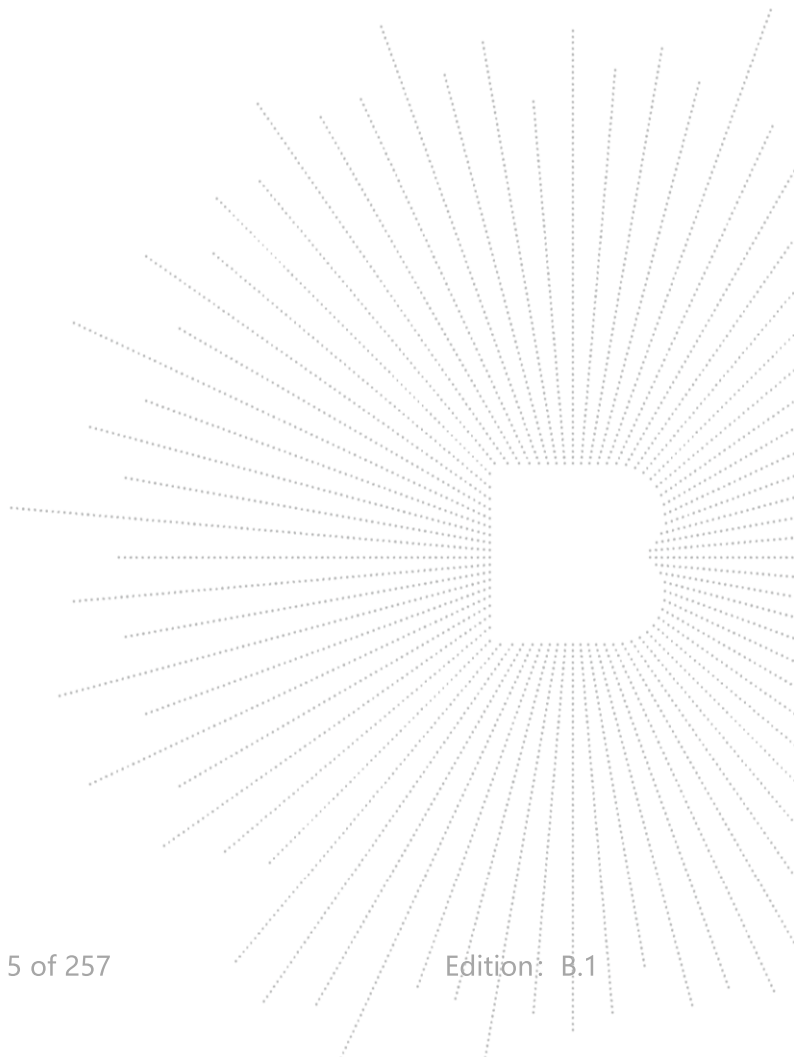

## 2. Test Summary

The Product has been tested according to the following specifications:

| No. | Test Parameter                          | Clause No.              | Results |
|-----|---|-------------------------|---------|
| 1   | Spurious Radiated Emissions             | 15.209(a)<br>15.407 (b) | PASS    |
| 2   | Conducted Emission                      | 15.207                  | PASS    |
| 3   | 26 dB and 99% Emission Bandwidth        | 15.407 a<br>15.1049     | PASS    |
| 4   | Minimum 6 dB bandwidth                  | 15.407(e)               | PASS    |
| 5   | Maximum Conducted Output Power          | 15.407 a                | PASS    |
| 6   | Band Edge                               | 15.407 b                | PASS    |
| 7   | Power Spectral Density                  | 15.407 a                | PASS    |
| 8   | Spurious Emissions at Antenna Terminals | 15.407 b                | PASS    |
| 9   | Antenna Requirement                     | 15.203                  | PASS    |

Note: The device shall automatically discontinue transmission in case of either absence of information to transmit or operational failure.

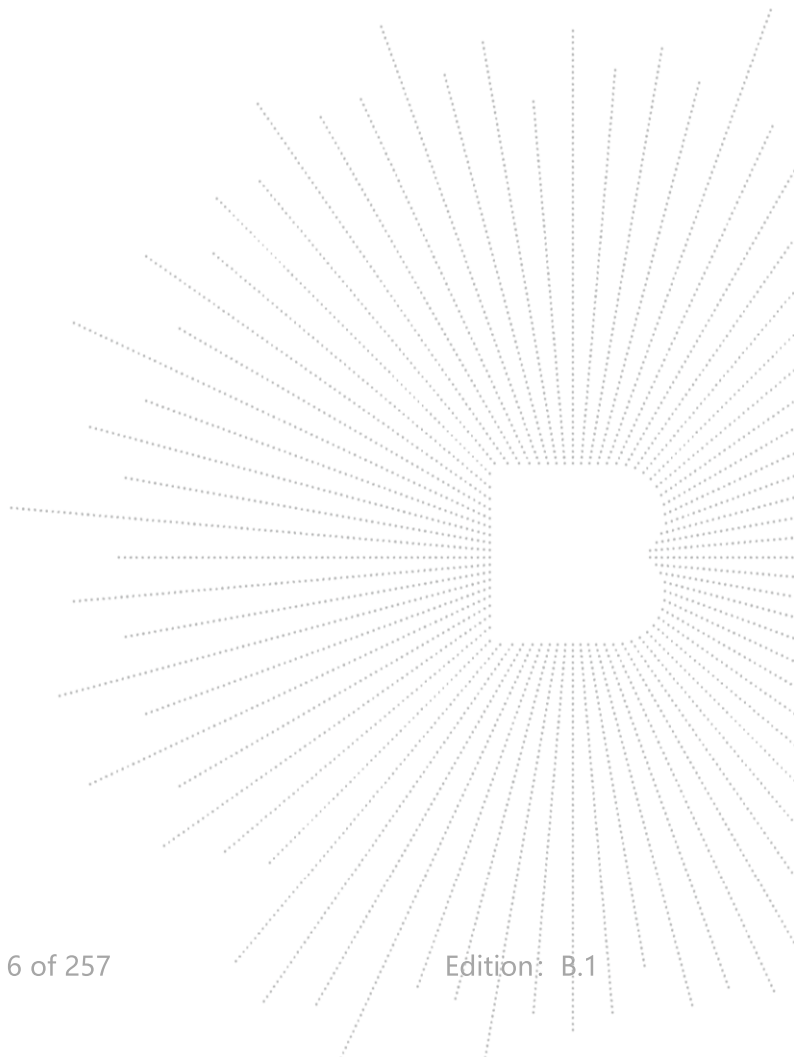

### 3. Measurement Uncertainty

Where relevant, the following measurement uncertainty levels have been estimated for tests performed on the Product as specified in CISPR 16-4-2. This uncertainty represents an expanded uncertainty expressed at approximately the 95% confidence level using a coverage factor of k=2.

| No. | Item   | Uncertainty |
|-----|--|-------------|
| 1   | 3m chamber Radiated spurious emission(9kHz-30MHz)  | U=3.7dB     |
| 2   | 3m chamber Radiated spurious emission(30MHz-1GHz)  | U=4.3dB     |
| 3   | 3m chamber Radiated spurious emission(1GHz-18GHz)  | U=4.5dB     |
| 4   | 3m chamber Radiated spurious emission(18GHz-40GHz) | U=3.34dB    |
| 5   | Conducted Emission(150kHz-30MHz)                   | U=3.20dB    |
| 6   | Conducted Adjacent channel power                   | U=1.38dB    |
| 7   | Conducted output power uncertainty Above 1G        | U=1.576dB   |
| 8   | Conducted output power uncertainty below 1G        | U=1.28dB    |
| 9   | humidity uncertainty                               | U=5.3%      |
| 10  | Temperature uncertainty                            | U=0.59°C    |

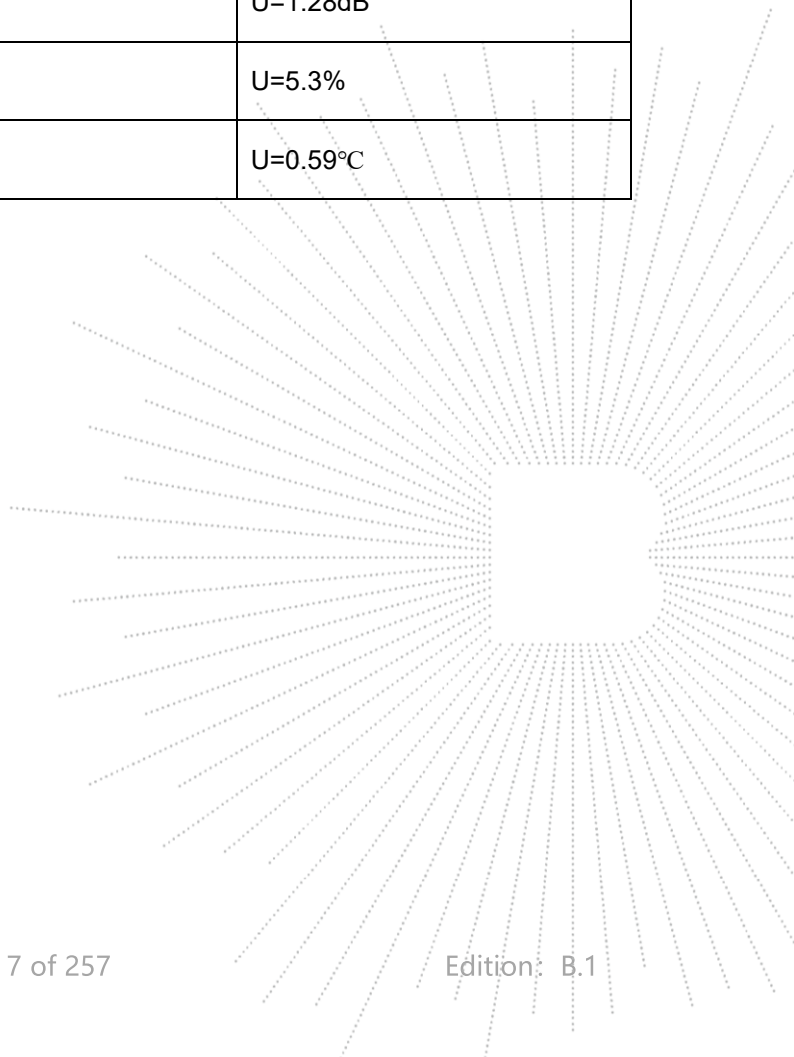

## 4. Product Information And Test Setup

### 4.1 Product Information

|                                 |   |
|---------------------------------|---|
| Model/Type reference:           | RLC-510WA<br>W320,B500W   |
| Model differences:              | All the model are the same circuit and RF module, except model names.   |
| Hardware Version:               | N/A   |
| Software Version:               | N/A   |
| IEEE 802.11 WLAN Mode Supported | 802.11a/n/ac(20MHz channel bandwidth)<br>802.11n/ac(40MHz channel bandwidth)<br>802.11ac(80MHz channel bandwidth)<br>5180-5240MHz for 802.11a/n/ac(HT20);<br>5190-5230MHz for 802.11n/ac(HT40);<br>5210MHz for 802.11 ac80;<br>5260-5320MHz for 802.11a/n/ac(HT20);<br>5270-5310MHz for 802.11n/ac(HT40);<br>5290MHz for 802.11 ac80;                 |
| Operation Frequency:            | 5500-5700MHz for 802.11a/n/ac(HT20);<br>5410-5670MHz for 802.11n/ac(HT40);<br>5530MHz for 802.11 ac80;<br>5745-5825 MHz for 802.11a/n/ac(HT20);<br>5755-5795 MHz for 802.11n/ac(HT40);<br>5775MHz for 802.11 ac80   |
| Data Rate                       | 802.11a: 6,9,12,18,24,36,48,54Mbps;<br>802.11n(HT20/HT40):MCS0-MCS15;<br>802.11ac(VHT20): NSS1, MCS0-MCS8<br>802.11ac(VHT40/VHT80):NSS1, MCS0-MCS9  |
| Type of Modulation:             | OFDM with BPSK/QPSK/16QAM/64QAM/256QAM for 802.11a/n/ac;  |
| Antenna installation:           | External antenna*2<br>5G: Antenna A & B: 2.55 dBi   |
| Antenna Gain:                   | Remark:<br><input checked="" type="checkbox"/> The antenna gain of the product comes from the antenna report provided by the customer, and the test data is affected by the customer information.<br><input type="checkbox"/> The antenna gain of the product is provided by the customer, and the test data is affected by the customer information. |
| Ratings:                        | AC 120V/60Hz  |
| Adapter Information:            | Model: DCT12W120100US-B0<br>Input: 100-240V~50/60Hz 0.3A max.<br>Output: DC 12.0V 1.0A  |



## 4.2 Test Setup Configuration

See test photographs attached in *EUT TEST SETUP PHOTOGRAPHS* for the actual connections between Product and support equipment.

## 4.3 Support Equipment

| No. | Device Type    | Brand   | Model                 | Series No. | Note      |
|-----|----------------|---|-----------------------|------------|-----------|
| E-1 | WiFi IP Camera |  | RLC-510WA             | N/A        | EUT       |
| E-2 | Adapter        | N/A   | DCT12W12010<br>0US-B0 | N/A        | Auxiliary |
| E-3 | Router         | N/A   | N/A                   | N/A        | Auxiliary |
| E-4 | laptop         | N/A   | N/A                   | N/A        | Auxiliary |

| Item | Shielded Type | Ferrite Core | Length | Note                |
|------|---------------|--------------|--------|---------------------|
| C-1  | N/A           | N/A          | 3M     | DC cable unshielded |

### Notes:

1. All the equipment/cables were placed in the worst-case configuration to maximize the emission during the test.
2. Grounding was established in accordance with the manufacturer's requirements and conditions for the intended use.

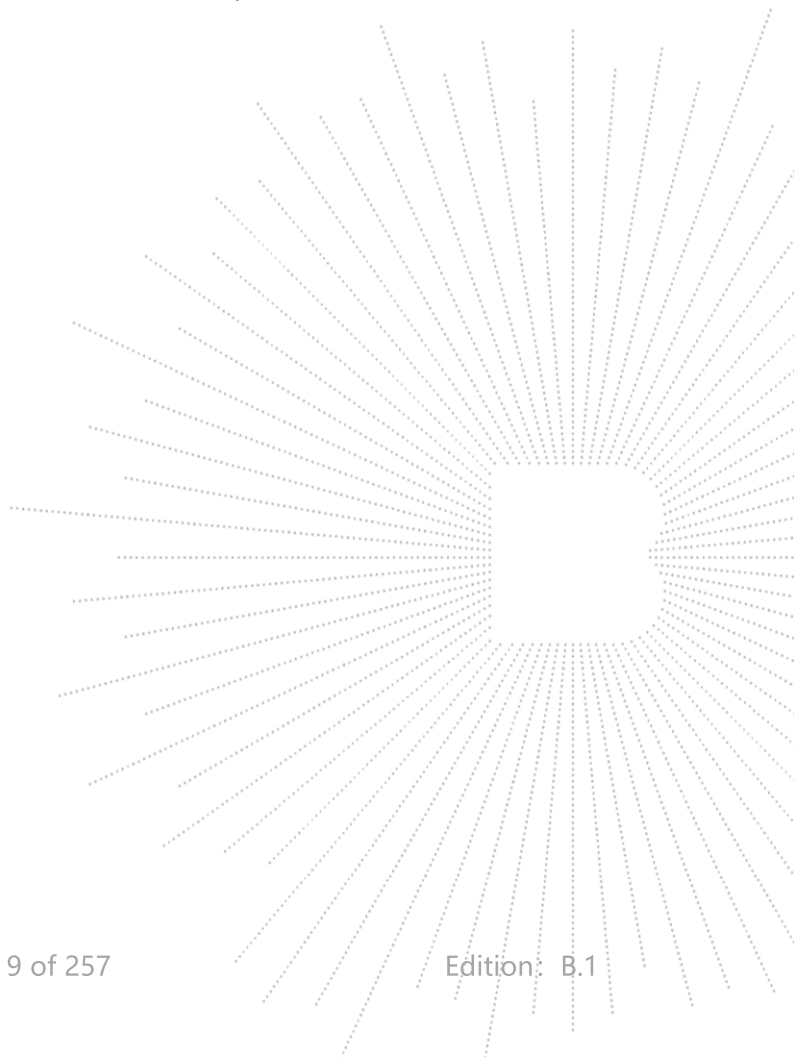

## 4.4 Channel List

| <b>(U-NII-1) 5180MHz-5240MHz</b>  |                |                        |                |                  |
|-----------------------------------|----------------|------------------------|----------------|------------------|
| <b>Bandwidth</b>                  | <b>Channel</b> | <b>Frequency (MHz)</b> | <b>Channel</b> | <b>Frequency</b> |
| 20MHz                             | 36             | 5180                   | 40             | 5200             |
|                                   | 44             | 5220                   | 48             | 5240             |
| 40MHz                             | 38             | 5190                   | 46             | 5230             |
| 80MHz                             | 42             | 5210                   |                |                  |
| <b>(U-NII-2A) 5260MHz-5320MHz</b> |                |                        |                |                  |
| <b>Bandwidth</b>                  | <b>Channel</b> | <b>Frequency (MHz)</b> | <b>Channel</b> | <b>Frequency</b> |
| 20MHz                             | 52             | 5260                   | 56             | 5280             |
|                                   | 60             | 5300                   | 64             | 5320             |
| 40MHz                             | 54             | 5270                   | 62             | 5310             |
| 80MHz                             | 58             | 5290                   |                |                  |
| <b>(U-NII-2C) 5500MHz-5700MHz</b> |                |                        |                |                  |
| <b>Bandwidth</b>                  | <b>Channel</b> | <b>Frequency (MHz)</b> | <b>Channel</b> | <b>Frequency</b> |
| 20MHz                             | 100            | 5500                   | 105            | 5520             |
|                                   | 108            | 5540                   | 112            | 5560             |
|                                   | 116            | 5580                   | 132            | 5660             |
|                                   | 136            | 5680                   | 140            | 5700             |
| 40MHz                             | 102            | 5510                   | 110            | 5550             |
|                                   | 134            | 5670                   | 142            | 5710             |
| 80MHz                             | 106            | 5530                   |                |                  |
| <b>(U-NII-3) 5745MHz-5825MHz</b>  |                |                        |                |                  |
| <b>Bandwidth</b>                  | <b>Channel</b> | <b>Frequency (MHz)</b> | <b>Channel</b> | <b>Frequency</b> |
| 20MHz                             | 149            | 5745                   | 153            | 5765             |
|                                   | 157            | 5785                   | 161            | 5805             |
|                                   | 165            | 5825                   |                |                  |
| 40MHz                             | 151            | 5775                   | 159            | 5795             |
| 80MHz                             | 155            | 5775                   |                |                  |

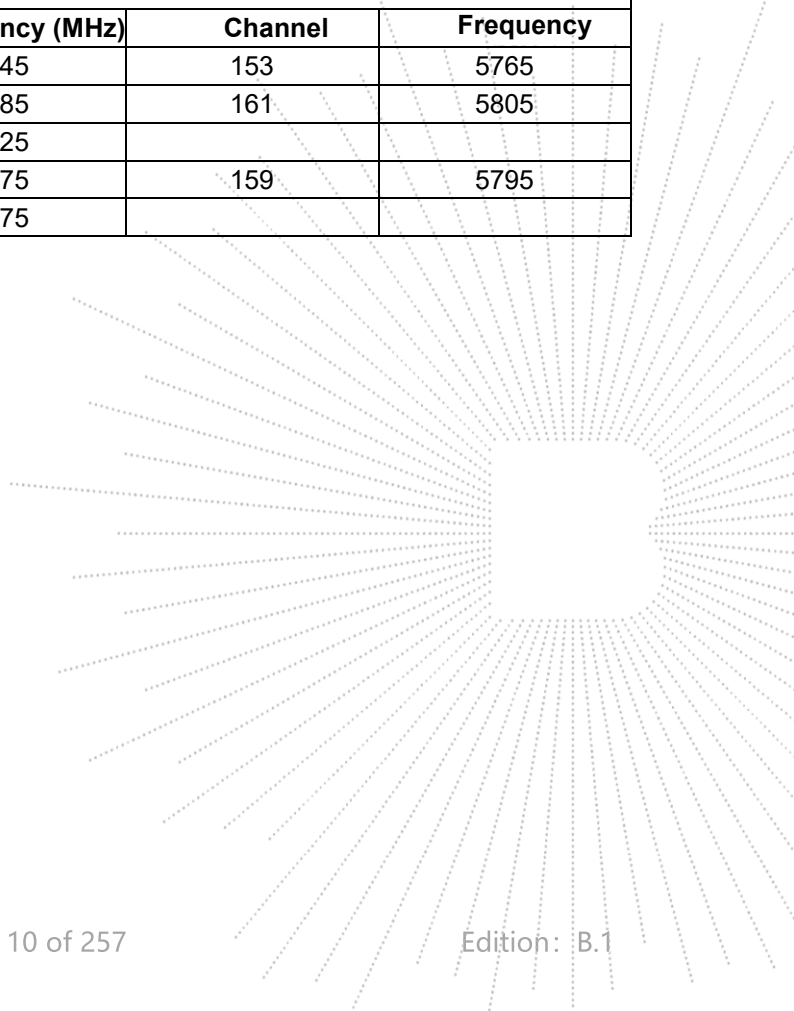

#### 4.5 Test Mode

To investigate the maximum EMI emission characteristics generates from EUT, the test system was pre-scanning tested base on the consideration of following EUT operation mode or test configuration mode which possible have effect on EMI emission level. Each of these EUT operation mode(s) or test configuration mode(s) mentioned above was evaluated respectively.

| Pretest Mode | Description   |
|--------------|---|
| Mode 1       | 802.11a / n/ ac 20 CH36/ CH40/ CH 48<br>802.11a / n/ ac 20 CH52/ CH56/ CH 64<br>802.11a / n/ ac 20 CH100/ CH116/ CH 140<br>802.11a /n/ ac 20 CH149/ CH157/ CH 165 |
| Mode 2       | 802.11n/ ac40 CH38/ CH 46<br>802.11n/ ac40 CH54/ CH 62<br>802.11n/ ac40 CH102/ CH 110/CH134<br>802.11n/ ac40 CH 151 / CH 159                                      |
| Mode 3       | 802.11 ac80 CH 42/ CH 58/ CH 106/ CH 155  |
| Mode 4       | Link Mode   |

Note:

(1) The measurements are performed at all Bit Rate of Transmitter, the worst data was reported.

#### 4.6 Table Of Parameters Of Text Software Setting

During testing channel & power controlling software provided by the customer was used to control the operating channel as well as the output power level. The RF output power selection is for the setting of RF output power expected by the customer and is going to be fixed on the firmware of the final end product power parameters

| Test software Version | CMD |     |     |
|-----------------------|-----|-----|-----|
| Parameters            | DEF | DEF | DEF |

#### 4.7 Antenna

##### 5.1G&5.3G&5.6G&5.8G

| Ant. | Brand | Model Name | Antenna Type     | Gain (dBi) | NOTE |
|------|-------|------------|------------------|------------|------|
| A    | N/A   | N/A        | External antenna | 2.55       | N/A  |
| B    | N/A   | N/A        | External antenna | 2.55       | N/A  |

EUT has two External antenna with Max gain GANT 2.55 dBi on every antenna, CDD device with one spatial streams, also can operat with one spatial streams according to KDB662911 D01 v02r01, Directional gain= GANT + Array Gain, where Array Gain is as follows.

- 1)For power spectral density(PSD) measurements,  
 $\text{Array Gain} = 10\log(\text{NANT}/\text{NSS})\text{dB} = 10\log(2/1) = 3.01 \text{ dBi}$ ,  
 So the directional gain for PSD is 5.56 dBi
- 2)For power measurements,  
 The Array gain=0 for  $\text{NANT} \leq 4$ ,  
 So the directional gain for Power measurements is 2.55 dBi

## 5. Test Facility And Test Instrument Used

### 5.1 Test Facility

All measurement facilities used to collect the measurement data are located at Shenzhen BCTC Testing Co., Ltd. Address: 1-2/F., Building B, Pengzhou Industrial Park, No.158, Fuyuan 1st Road, Zhancheng, Fuhai Subdistrict, Bao'an District, Shenzhen, Guangdong, China. The site and apparatus are constructed in conformance with the requirements of ANSI C63.4 and CISPR 16-1-1 other equivalent standards.

FCC Test Firm Registration Number: 712850

A2LA certificate registration number is: CN1212

ISED Registered No.: 23583

ISED CAB identifier: CN0017

### 5.2 Test Instrument Used

| Conducted Emissions Test |              |            |             |                |                |
|--------------------------|--------------|------------|-------------|----------------|----------------|
| Equipment                | Manufacturer | Model#     | Serial#     | Last Cal.      | Next Cal.      |
| Receiver                 | R&S          | ESR3       | 102075      | May 15, 2023   | May 14, 2024   |
| LISN                     | R&S          | ENV216     | 101375      | May 15, 2023   | May 14, 2024   |
| Software                 | Frad         | EZ-EMC     | EMC-CON 3A1 | \              | \              |
| Pulse limiter            | Schwarzbeck  | VTSD9561-F | 01323       | Sept. 22, 2023 | Sept. 21, 2024 |

| RF Conducted Test            |              |             |            |              |              |
|------------------------------|--------------|-------------|------------|--------------|--------------|
| Equipment                    | Manufacturer | Model#      | Serial#    | Last Cal.    | Next Cal.    |
| Power meter                  | Keysight     | E4419       | \          | May 15, 2023 | May 14, 2024 |
| Power Sensor (AV)            | Keysight     | E9300A      | \          | May 15, 2023 | May 14, 2024 |
| Signal Analyzer20kHz-26.5GHz | Keysight     | N9020A      | MY49100060 | May 15, 2023 | May 14, 2024 |
| Spectrum Analyzer9kHz-40GHz  | R&S          | FSP40       | 100363     | May 15, 2023 | May 14, 2024 |
| Radio frequency control box  | MAIWEI       | MW100-RFC B | \          | \            | \            |
| Software                     | MAIWEI       | MTS 8310    | \          | \            | \            |

| Radiated Emissions Test (966 Chamber01) |              |                   |              |              |              |
|---|--------------|-------------------|--------------|--------------|--------------|
| Equipment                               | Manufacturer | Model#            | Serial#      | Last Cal.    | Next Cal.    |
| 966 chamber                             | ChengYu      | 966 Room          | 966          | May 15, 2023 | May 14, 2026 |
| Receiver                                | R&S          | ESR3              | 102075       | May 15, 2023 | May 14, 2024 |
| Receiver                                | R&S          | ESRP              | 101154       | May 15, 2023 | May 14, 2024 |
| Amplifier                               | Schwarzbeck  | BBV9744           | 9744-0037    | May 15, 2023 | May 14, 2024 |
| TRILOG Broadband Antenna                | Schwarzbeck  | VULB9163          | 942          | May 29, 2023 | May 28, 2024 |
| Loop Antenna(9KHz -30MHz)               | Schwarzbeck  | FMZB1519B         | 00014        | May 31, 2023 | May 30, 2024 |
| Amplifier                               | SKET         | LAPA_01G18 G-45dB | SK2021040901 | May 15, 2023 | May 14, 2024 |
| Horn Antenna                            | Schwarzbeck  | BBHA9120D         | 1541         | May 31, 2023 | May 30, 2024 |
| Amplifier(18G Hz-40GHz)                 | MITEQ        | TTA1840-35-HG     | 2034381      | May 15, 2023 | May 14, 2024 |
| Horn Antenna(18G Hz-40GHz)              | Schwarzbeck  | BBHA9170          | 00822        | May 31, 2023 | May 30, 2024 |
| Spectrum Analyzer9kHz-40GHz             | R&S          | FSP40             | 100363       | May 15, 2023 | May 14, 2024 |
| Software                                | Frad         | EZ-EMC            | FA-03A2 RE   | \            | \            |

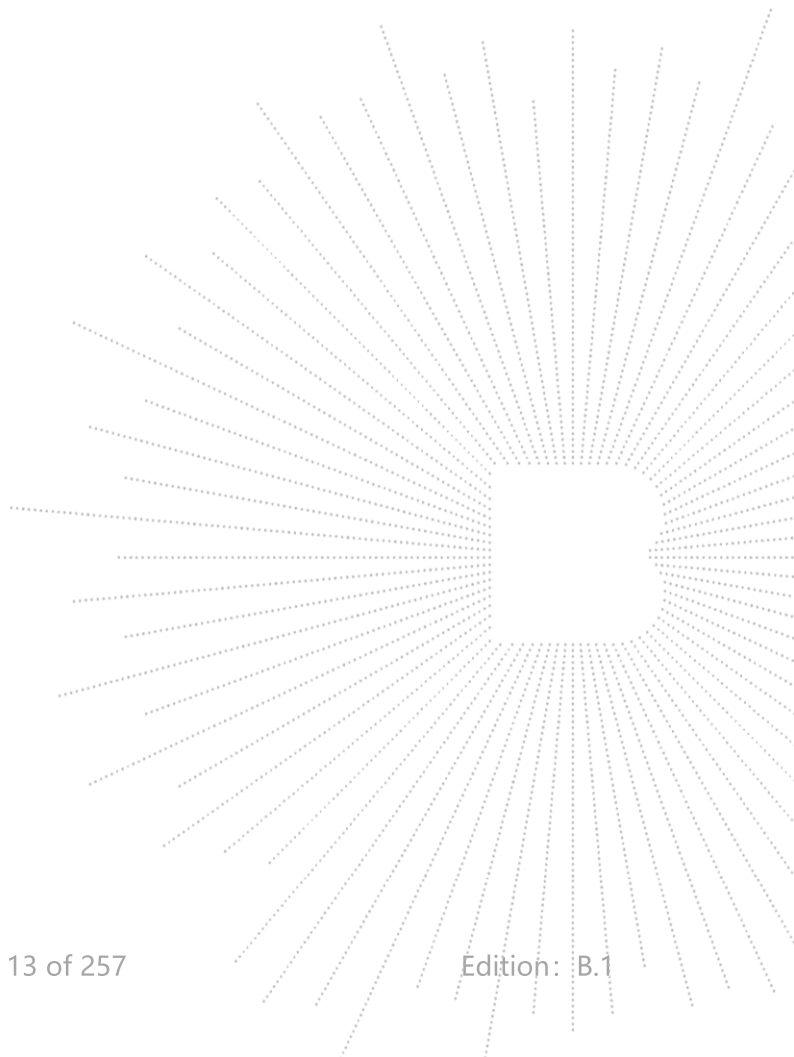

## 6. Conducted Emissions

### 6.1 Block Diagram Of Test Setup

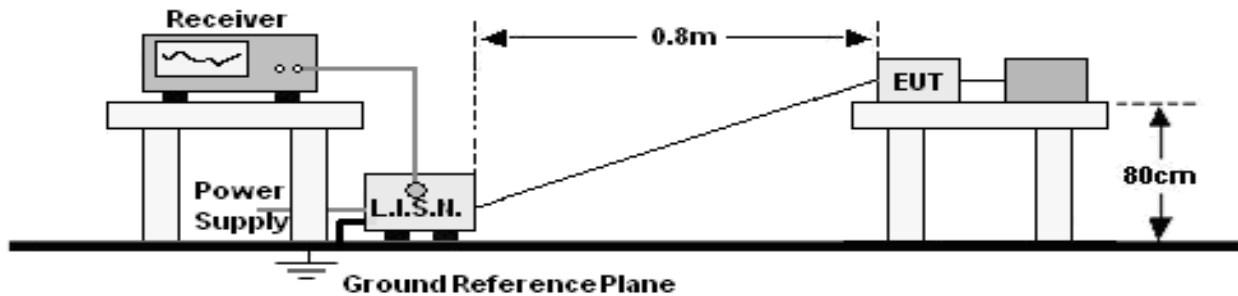

### 6.2 Limit

| Frequency (MHz) | Limit (dBuV) |           |
|-----------------|--------------|-----------|
|                 | Quas-peak    | Average   |
| 0.15 -0.5       | 66 - 56 *    | 56 - 46 * |
| 0.50 -5.0       | 56.00        | 46.00     |
| 5.0 -30.0       | 60.00        | 50.00     |

Notes:

- \*Decreasing linearly with logarithm of frequency.
- The lower limit shall apply at the transition frequencies.

### 6.3 Test Procedure

| Receiver Parameters | Setting  |
|---------------------|----------|
| Attenuation         | 10 dB    |
| Start Frequency     | 0.15 MHz |
| Stop Frequency      | 30 MHz   |
| IF Bandwidth        | 9 kHz    |

- The Product was placed on a nonconductive table 0.8 m above the horizontal ground reference plane, and 0.4 m from the vertical ground reference plane, and connected to the main through Line Impedance Stability Network (L.I.S.N).
- The RBW of the receiver was set at 9 kHz in 150 kHz ~ 30MHz with Peak and AVG detector in Max Hold mode. Run the receiver's pre-scan to record the maximum disturbance generated from Product in all power lines in the full band.
- For each frequency whose maximum record was higher or close to limit, measure its QP and AVG values and record.

### 6.4 EUT Operating Conditions

The EUT was configured for testing in a typical fashion (as a customer would normally use it). The EUT has been programmed to continuously transmit during test. This operating condition was tested and used to collect the included data.

### 6.5 Test Result

|              |        |                    |             |
|--------------|--------|--------------------|-------------|
| Temperature: | 26 °C  | Relative Humidity: | 54%         |
| Pressure:    | 101KPa | Test Voltage:      | AC120V/60Hz |
| Test Mode:   | Mode 4 | Polarization :     | L           |

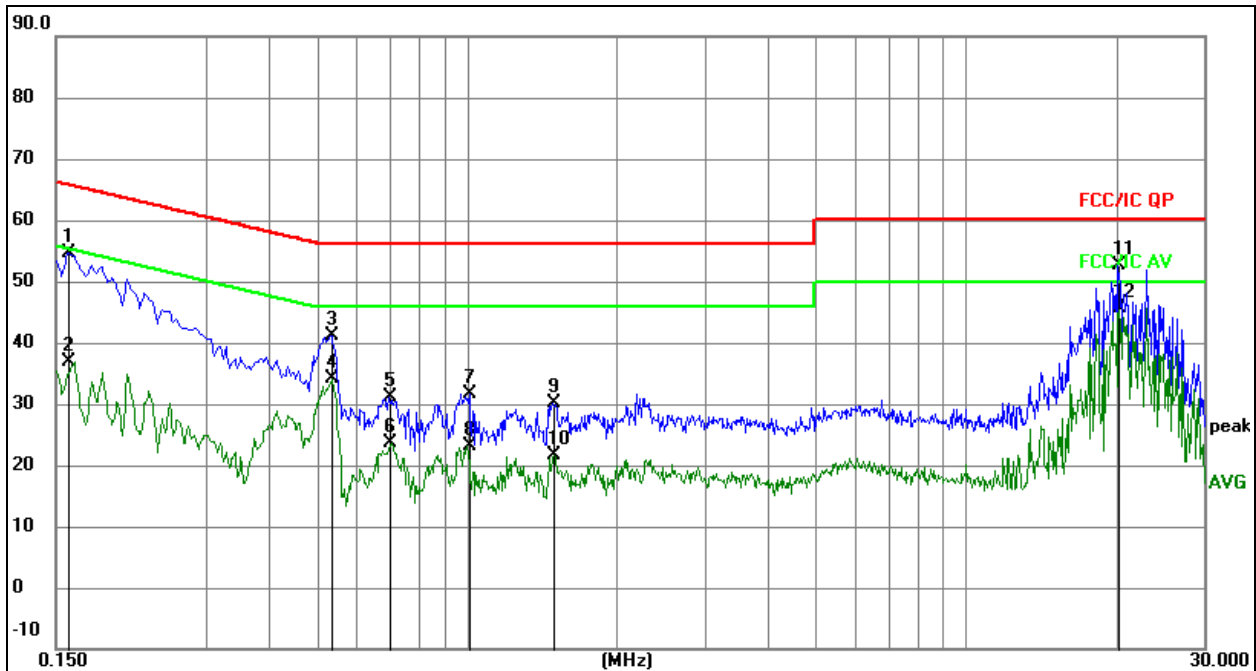

**Remark:**

1. All readings are Quasi-Peak and Average values.
2. Factor = Insertion Loss + Cable Loss.
3. Measurement = Reading Level + Correct Factor
4. Over = Measurement - Limit

| No. | Mk. | Freq.<br>MHz | Reading<br>Level | Correct<br>Factor<br>dB | Measure-<br>ment<br>dBuV | Limit<br>dBuV | Over<br>dB | Detector |
|-----|-----|--------------|------------------|-------------------------|--------------------------|---------------|------------|----------|
| 1   |     | 0.1590       | 34.90            | 19.75                   | 54.65                    | 65.52         | -10.87     | QP       |
| 2   |     | 0.1590       | 17.12            | 19.75                   | 36.87                    | 55.52         | -18.65     | AVG      |
| 3   |     | 0.5370       | 21.40            | 19.84                   | 41.24                    | 56.00         | -14.76     | QP       |
| 4   |     | 0.5370       | 14.17            | 19.84                   | 34.01                    | 46.00         | -11.99     | AVG      |
| 5   |     | 0.6990       | 11.20            | 19.84                   | 31.04                    | 56.00         | -24.96     | QP       |
| 6   |     | 0.6990       | 3.85             | 19.84                   | 23.69                    | 46.00         | -22.31     | AVG      |
| 7   |     | 1.0140       | 11.78            | 19.95                   | 31.73                    | 56.00         | -24.27     | QP       |
| 8   |     | 1.0140       | 3.21             | 19.95                   | 23.16                    | 46.00         | -22.84     | AVG      |
| 9   |     | 1.4910       | 10.24            | 19.95                   | 30.19                    | 56.00         | -25.81     | QP       |
| 10  |     | 1.4910       | 1.56             | 19.95                   | 21.51                    | 46.00         | -24.49     | AVG      |
| 11  |     | 20.2560      | 32.69            | 19.99                   | 52.68                    | 60.00         | -7.32      | QP       |
| 12  | *   | 20.2560      | 25.65            | 19.99                   | 45.64                    | 50.00         | -4.36      | AVG      |

|              |        |                    |             |
|--------------|--------|--------------------|-------------|
| Temperature: | 26 °C  | Relative Humidity: | 54%         |
| Pressure:    | 101KPa | Test Voltage:      | AC120V/60Hz |
| Test Mode:   | Mode 4 | Polarization :     | N           |

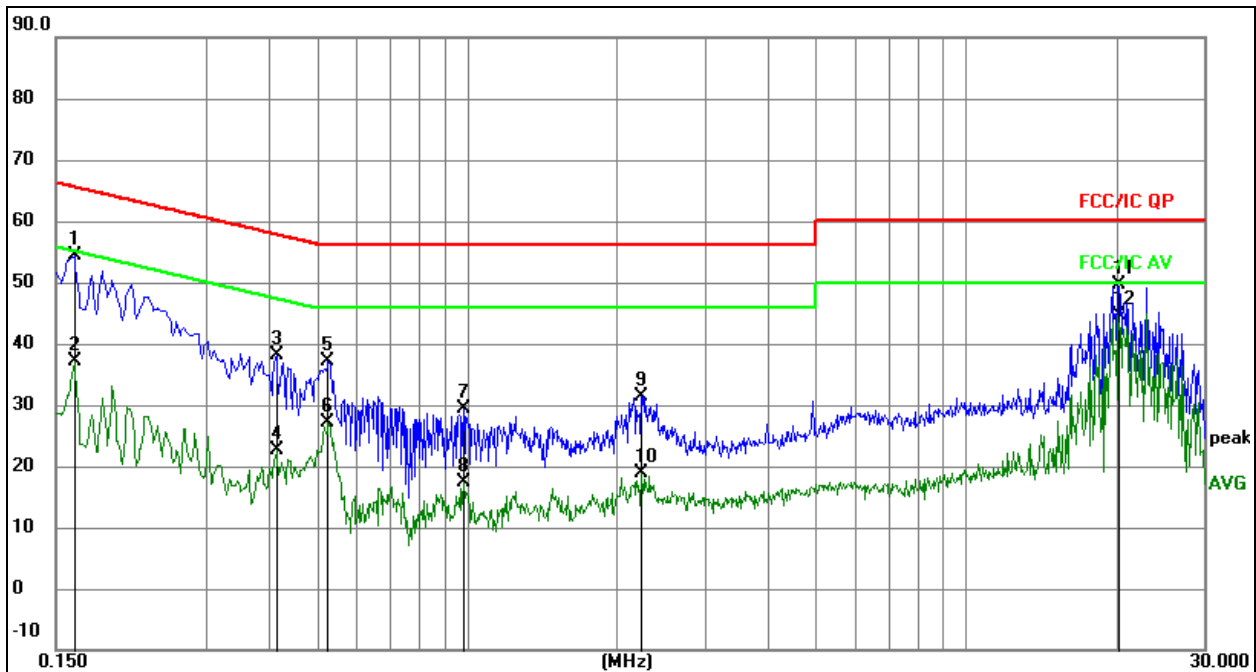
**Remark:**

1. All readings are Quasi-Peak and Average values.
2. Factor = Insertion Loss + Cable Loss.
3. Measurement = Reading Level + Correct Factor
4. Over = Measurement - Limit

| No. | Mk. | Freq.<br>MHz | Reading<br>Level | Correct<br>Factor<br>dB | Measure-<br>ment<br>dBuV | Limit<br>dBuV | Over<br>dB | Detector |
|-----|-----|--------------|------------------|-------------------------|--------------------------|---------------|------------|----------|
| 1   |     | 0.1633       | 34.61            | 19.76                   | 54.37                    | 65.29         | -10.92     | QP       |
| 2   |     | 0.1633       | 17.48            | 19.76                   | 37.24                    | 55.29         | -18.05     | AVG      |
| 3   |     | 0.4148       | 18.38            | 19.84                   | 38.22                    | 57.55         | -19.33     | QP       |
| 4   |     | 0.4148       | 2.85             | 19.84                   | 22.69                    | 47.55         | -24.86     | AVG      |
| 5   |     | 0.5265       | 17.18            | 19.84                   | 37.02                    | 56.00         | -18.98     | QP       |
| 6   |     | 0.5265       | 7.26             | 19.84                   | 27.10                    | 46.00         | -18.90     | AVG      |
| 7   |     | 0.9839       | 9.40             | 19.94                   | 29.34                    | 56.00         | -26.66     | QP       |
| 8   |     | 0.9839       | -2.53            | 19.94                   | 17.41                    | 46.00         | -28.59     | AVG      |
| 9   |     | 2.2367       | 11.34            | 20.03                   | 31.37                    | 56.00         | -24.63     | QP       |
| 10  |     | 2.2367       | -1.22            | 20.03                   | 18.81                    | 46.00         | -27.19     | AVG      |
| 11  |     | 20.1625      | 29.63            | 19.99                   | 49.62                    | 60.00         | -10.38     | QP       |
| 12  | *   | 20.1625      | 24.55            | 19.99                   | 44.54                    | 50.00         | -5.46      | AVG      |



## 7. Radiated Emissions

### 7.1 Block Diagram Of Test Setup

(A) Radiated Emission Test-Up Frequency Below 30MHz

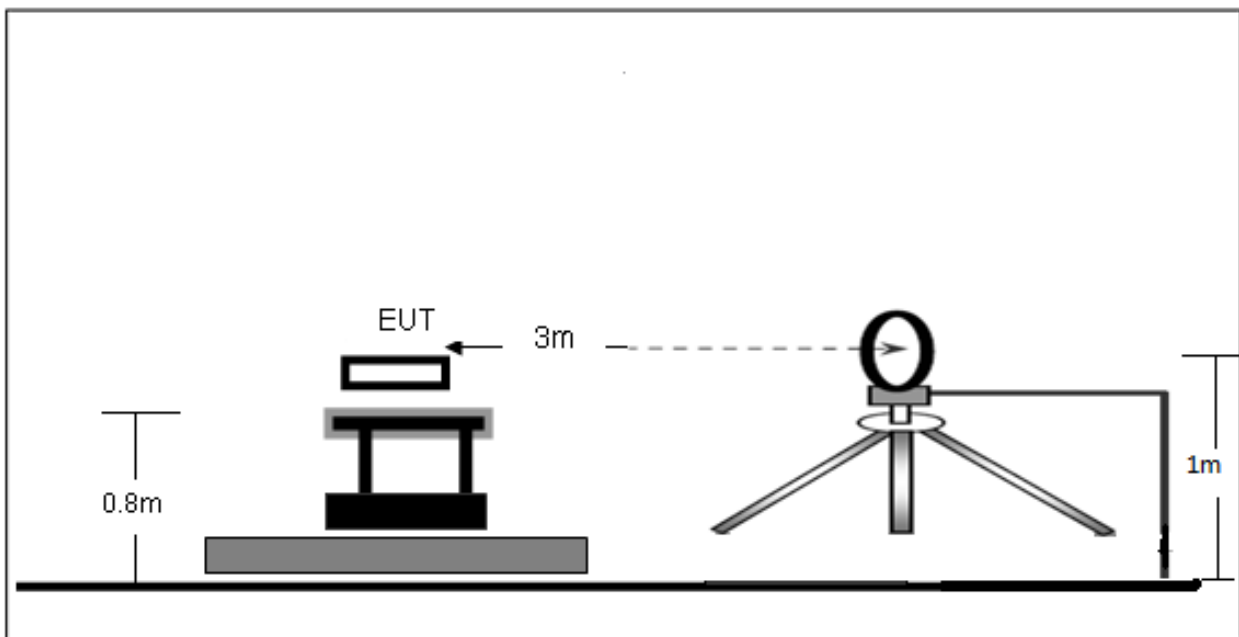

(B) Radiated Emission Test-Up Frequency 30MHz~1GHz

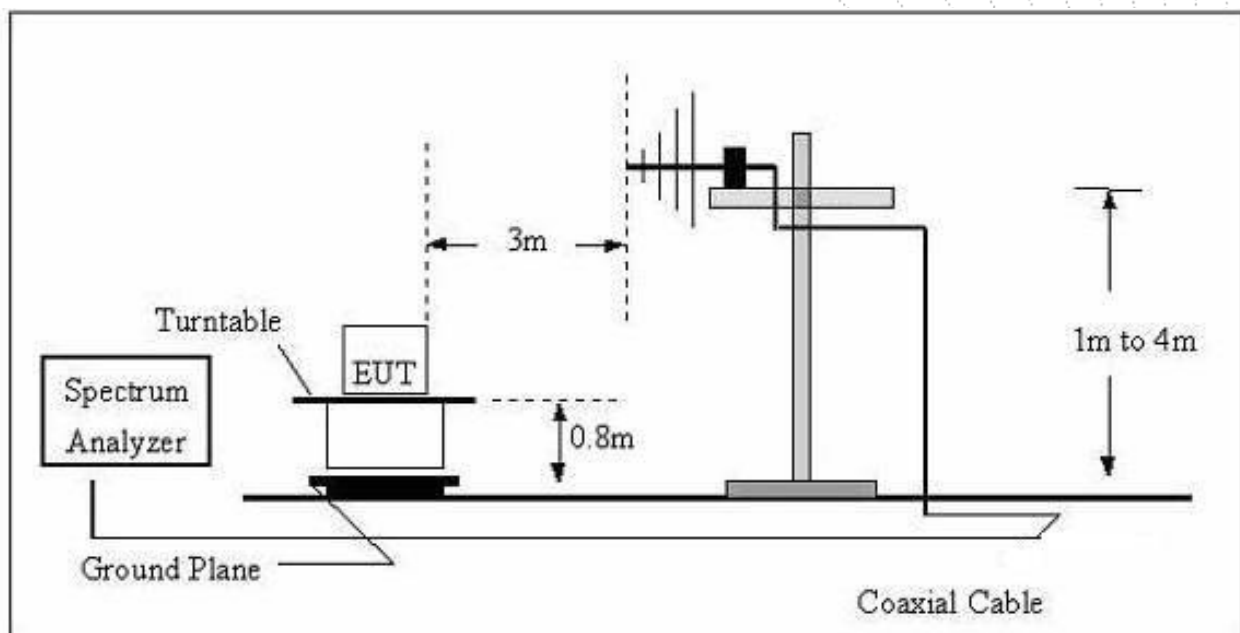

## (C) Radiated Emission Test-Up Frequency Above 1GHz

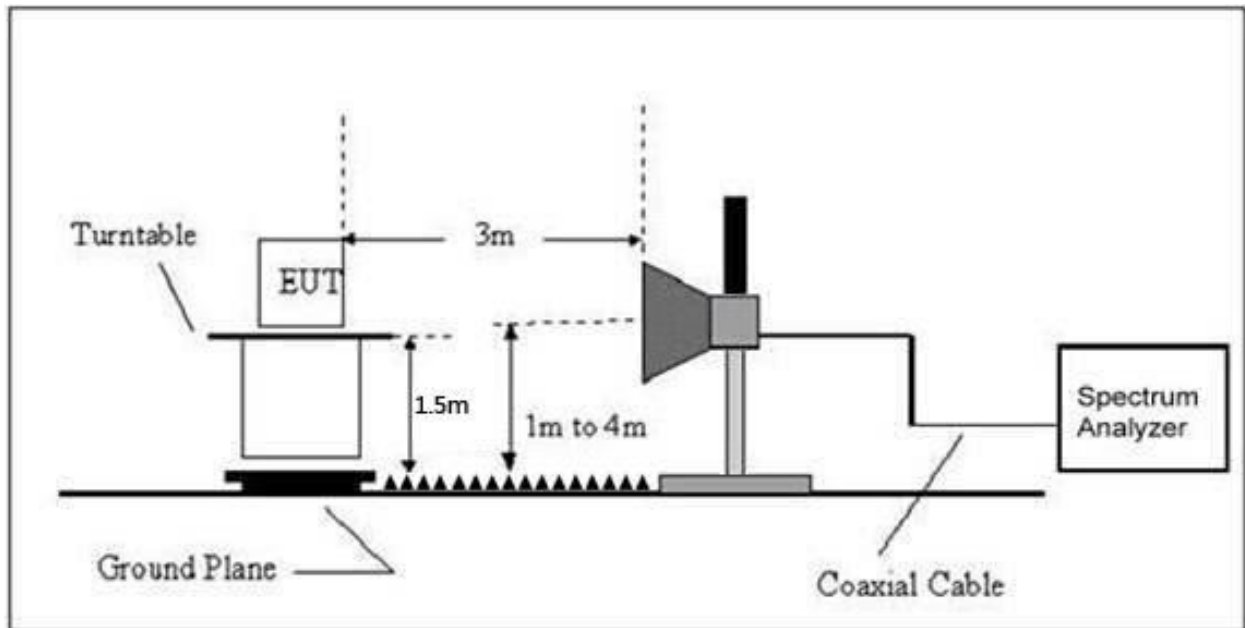

## 7.2 Limit

20dBc in any 100 kHz bandwidth outside the operating frequency band. In case the emission fall within the restricted band specified on 15.205(a), then the 15.209(a) limit in the table below has to be followed.

| Frequency<br>(MHz) | Field Strength<br>uV/m | Distance<br>(m) | Field Strength Limit at 3m Distance |                                      |
|--------------------|------------------------|-----------------|-------------------------------------|--------------------------------------|
|                    |                        |                 | uV/m                                | dBuV/m                               |
| 0.009 ~ 0.490      | 2400/F(kHz)            | 300             | 10000 * 2400/F(kHz)                 | 20log <sup>(2400/F(kHz))</sup> + 80  |
| 0.490 ~ 1.705      | 24000/F(kHz)           | 30              | 100 * 24000/F(kHz)                  | 20log <sup>(24000/F(kHz))</sup> + 40 |
| 1.705 ~ 30         | 30                     | 30              | 100 * 30                            | 20log <sup>(30)</sup> + 40           |
| 30 ~ 88            | 100                    | 3               | 100                                 | 20log <sup>(100)</sup>               |
| 88 ~ 216           | 150                    | 3               | 150                                 | 20log <sup>(150)</sup>               |
| 216 ~ 960          | 200                    | 3               | 200                                 | 20log <sup>(200)</sup>               |
| Above 960          | 500                    | 3               | 500                                 | 20log <sup>(500)</sup>               |

## Limits Of Radiated Emission Measurement (Above 1000MHz)

| Frequency (MHz) | Limit (dBuV/m) (at 3M) |         |
|-----------------|------------------------|---------|
|                 | Peak                   | Average |
| Above 1000      | 74                     | 54      |

## Notes:

- (1)The limit for radiated test was performed according to FCC PART 15C.
- (2)The tighter limit applies at the band edges.
- (3) Emission level (dBuV/m)=20log Emission level (uV/m).

### 7.3 Test Procedure

The test site semi-anechoic chamber has met the requirement of NSA tolerance 4 dB according to the standards: ANSI C63.10-2013. The test distance is 3m. The setup is according to the requirements in Section 13.1.4.1 of ANSI C63.10-2013 and CAN/CSA-CEI/IEC CISPR 22.

This test is required for any spurious emission that falls in a Restricted Band, as defined in Section 15.205.

It must be performed with the highest gain of each type of antenna proposed for use with the EUT. Use the following spectrum analyzer settings:

| Spectrum Parameter                    | Setting  |
|---------------------------------------|--|
| Attenuation                           | Auto   |
| Start Frequency                       | 1000 MHz   |
| Stop Frequency                        | 10th carrier harmonic                            |
| RB / VB (emission in restricted band) | 1 MHz / 1 MHz for Peak, 1 MHz / 10Hz for Average |

| Receiver Parameter     | Setting                          |
|------------------------|----------------------------------|
| Attenuation            | Auto                             |
| Start ~ Stop Frequency | 9kHz~150kHz / RB 200Hz for QP    |
| Start ~ Stop Frequency | 150kHz~30MHz / RB 9kHz for QP    |
| Start ~ Stop Frequency | 30MHz~1000MHz / RB 120kHz for QP |

- The measuring distance of at 3 m shall be used for measurements at frequency up to 1GHz. For frequencies above 1GHz, any suitable measuring distance may be used.
- The EUT was placed on the top of a rotating table 0.8 m for below 1GHz and 1.5m for above 1GHz the ground at a 3 meter. The table was rotated 360 degrees to determine the position of the highest radiation.
- The height of the equipment or of the substitution antenna shall be 0.8 m for below 1GHz and 1.5m for above 1GHz; the height of the test antenna shall vary between 1 m to 4 m. Both horizontal and vertical polarizations of the antenna are set to make the measurement.
- The initial step in collecting conducted emission data is a spectrum analyzer peak detector mode pre-scanning the measurement frequency range. Significant peaks are then marked and then Quasi Peak detector mode re-measured.
- If the Peak Mode measured value compliance with and lower than Quasi Peak Mode Limit, the EUT shall be deemed to meet QP Limits and then no additional QP Mode measurement performed.
- For the actual test configuration, please refer to the related Item –EUT Test Photos.

Note:

Both horizontal and vertical antenna polarities were tested and performed pretest to three orthogonal axis. The worst case emissions were reported

During the radiated emission test, the Spectrum Analyzer was set with the following configurations:

| Frequency Band (MHz) | Function | Resolution bandwidth | Video Bandwidth |
|----------------------|----------|----------------------|-----------------|
| 30 to 1000           | QP       | 120 kHz              | 300 kHz         |
| Above 1000           | Peak     | 1 MHz                | 1 MHz           |
|                      | Average  | 1 MHz                | 10 Hz           |

Note: for the frequency ranges below 30 MHz, a narrower RBW is used for these ranges but the measured value should add a RBW correction factor (RBWCF) where  $RBWCF [dB] = 10 \cdot \lg(100 [kHz] / \text{narrower RBW [kHz]})$ . , the narrower RBW is 1 kHz and RBWCF is 20 dB for the frequency 9 kHz to 150 kHz, and the narrower RBW is 10 kHz and RBWCF is 10 dB for the frequency 150 kHz to 30 MHz.

## 7.4 EUT Operating Conditions

The EUT was configured for testing in a typical fashion (as a customer would normally use it). The EUT has been programmed to continuously transmit during test. This operating condition was tested and used to collect the included data.

## 7.5 Test Result

Below 30MHz

|              |         |                    |              |
|--------------|---------|--------------------|--------------|
| Temperature: | 26°C    | Relative Humidity: | 24%          |
| Pressure:    | 101 kPa | Test Voltage :     | AC 120V/60Hz |
| Test Mode:   | Mode 4  | Polarization:      | --           |

| Freq.<br>(MHz) | Reading<br>(dBuV/m) | Limit<br>(dBuV/m) | Margin<br>(dB) | State<br>P/F |
|----------------|---------------------|-------------------|----------------|--------------|
| --             | --                  | --                | --             | PASS         |
| --             | --                  | --                | --             | PASS         |

**Note:**

The amplitude of spurious emissions which are attenuated by more than 20dB below the permissible value has no need to be reported.

Distance extrapolation factor =  $40 \log(\text{specific distance/test distance})(\text{dB})$ ;

Limit line = specific limits(dBuv) + distance extrapolation factor.

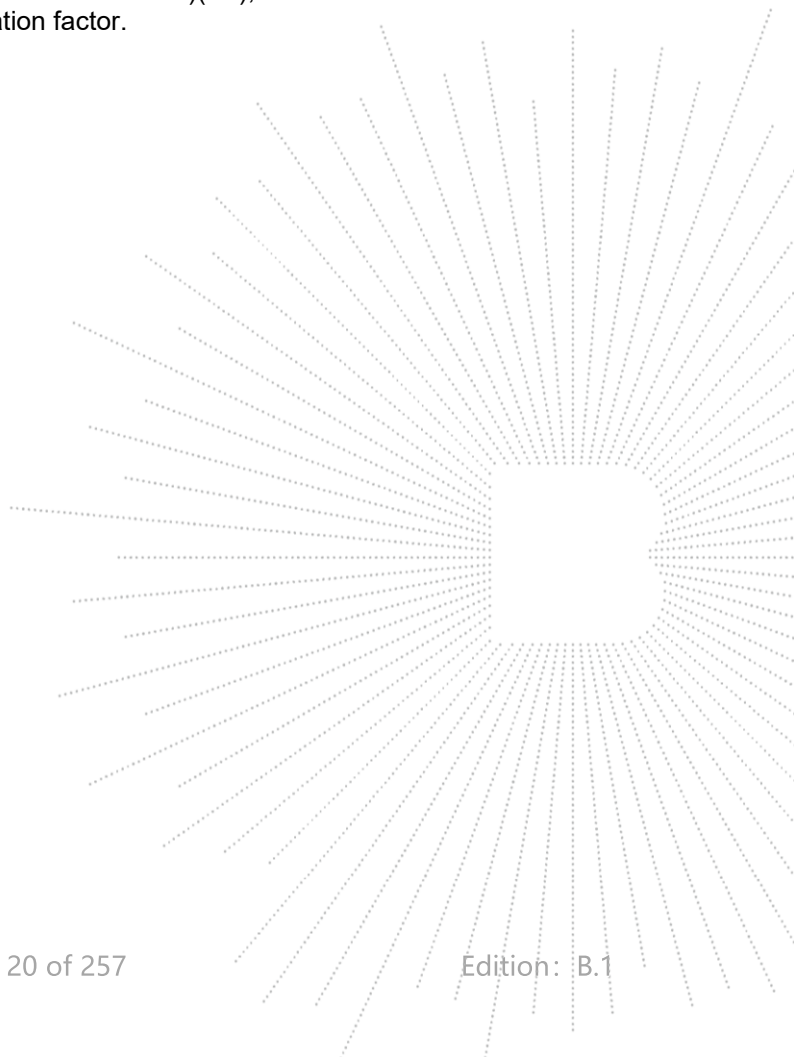

Between 30MHz – 1GHz

|              |        |                    |             |
|--------------|--------|--------------------|-------------|
| Temperature: | 26 °C  | Relative Humidity: | 54%         |
| Pressure:    | 101KPa | Test Voltage:      | AC120V/60Hz |
| Test Mode:   | Mode 4 | Polarization :     | Horizontal  |

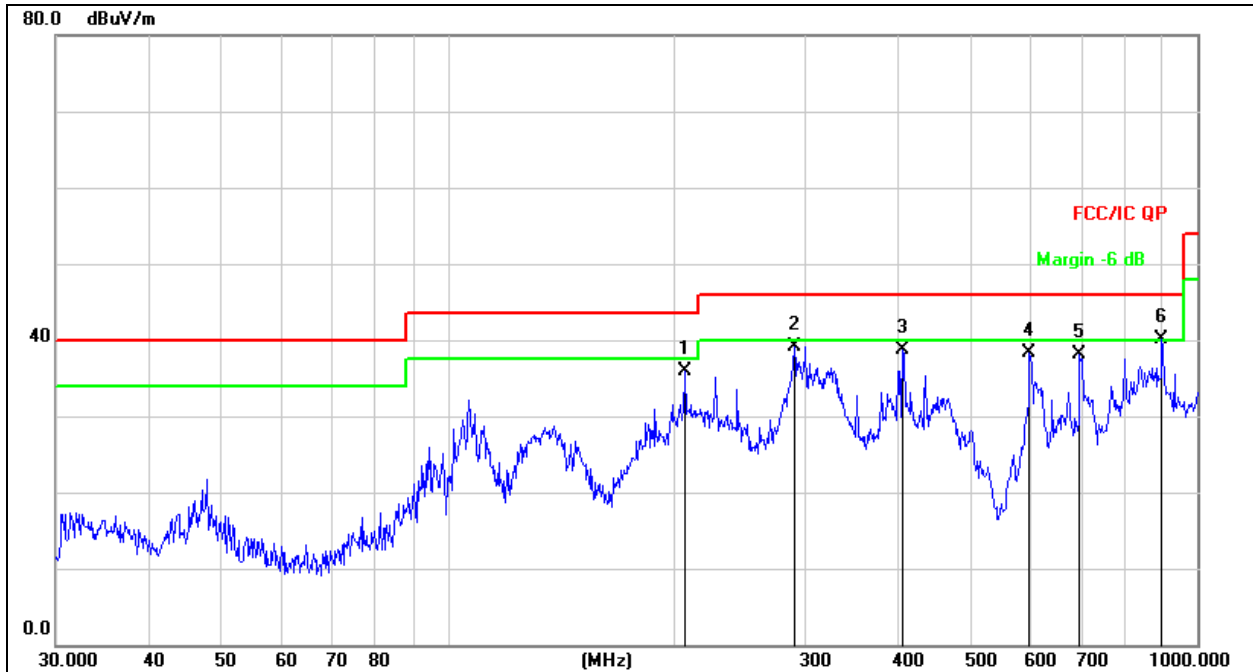

Remark:

1. Factor = Antenna Factor + Cable Loss – Pre-amplifier.
2. Measurement = Reading Level + Correct Factor
3. Over = Measurement - Limit

| No. | Mk. | Freq.<br>MHz | Reading<br>Level<br>dBuV | Correct<br>Factor<br>dB | Measure-<br>ment<br>dBuV/m | Limit<br>dB/m | Over<br>dB | Detector |
|-----|-----|--------------|--------------------------|-------------------------|----------------------------|---------------|------------|----------|
| 1   |     | 207.1226     | 51.49                    | -15.52                  | 35.97                      | 43.50         | -7.53      | QP       |
| 2   |     | 290.0172     | 52.63                    | -13.45                  | 39.18                      | 46.00         | -6.82      | QP       |
| 3   |     | 404.6665     | 49.51                    | -10.75                  | 38.76                      | 46.00         | -7.24      | QP       |
| 4   |     | 597.2234     | 45.46                    | -7.21                   | 38.25                      | 46.00         | -7.75      | QP       |
| 5   |     | 696.8567     | 43.85                    | -5.74                   | 38.11                      | 46.00         | -7.89      | QP       |
| 6   | *   | 896.9965     | 43.24                    | -3.17                   | 40.07                      | 46.00         | -5.93      | QP       |

|              |        |                    |             |
|--------------|--------|--------------------|-------------|
| Temperature: | 26 °C  | Relative Humidity: | 54%         |
| Pressure:    | 101KPa | Test Voltage:      | AC120V/60Hz |
| Test Mode:   | Mode 4 | Polarization :     | Vertical    |

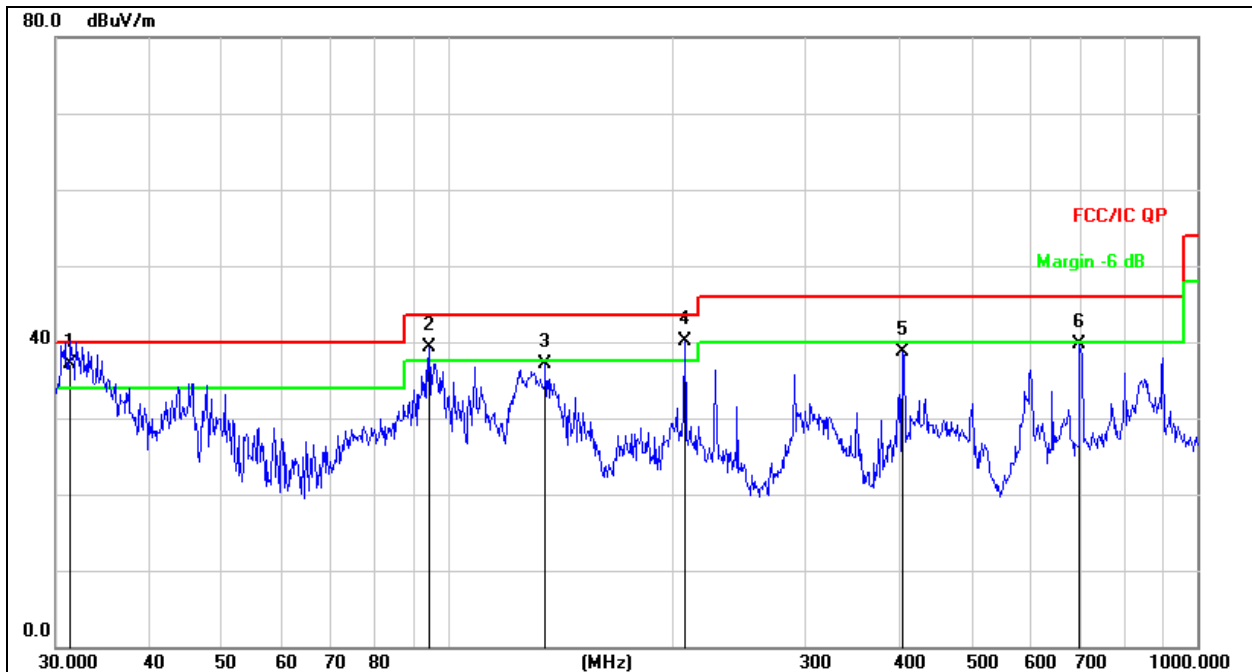
**Remark:**

1. Factor = Antenna Factor + Cable Loss – Pre-amplifier.
2. Measurement = Reading Level + Correct Factor
3. Over = Measurement - Limit

| No. | Mk. | Freq.<br>MHz | Reading<br>Level<br>dBuV | Correct<br>Factor<br>dB | Measure-<br>ment<br>dBuV/m | Limit<br>dB/m | Over<br>dB | Detector |
|-----|-----|--------------|--------------------------|-------------------------|----------------------------|---------------|------------|----------|
| 1   | *   | 31.3992      | 53.54                    | -16.38                  | 37.16                      | 40.00         | -2.84      | QP       |
| 2   | !   | 94.4284      | 56.09                    | -16.75                  | 39.34                      | 43.50         | -4.16      | QP       |
| 3   |     | 135.0319     | 55.51                    | -18.38                  | 37.13                      | 43.50         | -6.37      | QP       |
| 4   | !   | 207.1226     | 55.53                    | -15.52                  | 40.01                      | 43.50         | -3.49      | QP       |
| 5   |     | 404.6665     | 49.53                    | -10.75                  | 38.78                      | 46.00         | -7.22      | QP       |
| 6   |     | 696.8567     | 45.35                    | -5.74                   | 39.61                      | 46.00         | -6.39      | QP       |

|            |                    |
|------------|--------------------|
| Test Mode: | TX(5.1G) - 802.11a |
|------------|--------------------|

| Polar<br>(H/V)                     | Fre-<br>quency<br>(MHz) | Reading<br>Level<br>(dBuV/m) | Correct<br>Factor<br>(dB) | Measure-<br>ment<br>(dBuV/m) | Limits<br>(dBuV/m) | Over<br>(dB) | Detector<br>Type |
|------------------------------------|-------------------------|------------------------------|---------------------------|------------------------------|--------------------|--------------|------------------|
| Low Channel (5180 MHz)-Above 1G    |                         |                              |                           |                              |                    |              |                  |
| Vertical                           | 4434.15                 | 74.29                        | -20.73                    | 53.56                        | 68.20              | -14.64       | PK               |
| Vertical                           | 4434.15                 | 59.74                        | -20.73                    | 39.01                        | 54.00              | -14.99       | AV               |
| Vertical                           | 10360.01                | 63.13                        | -9.36                     | 53.77                        | 68.20              | -14.43       | PK               |
| Vertical                           | 10360.01                | 49.96                        | -9.36                     | 40.60                        | 54.00              | -13.40       | AV               |
| Vertical                           | 15540.20                | 63.59                        | -7.84                     | 55.75                        | 74.00              | -18.25       | PK               |
| Vertical                           | 15540.20                | 49.72                        | -7.84                     | 41.88                        | 54.00              | -12.12       | AV               |
| Horizontal                         | 4434.07                 | 71.17                        | -20.73                    | 50.44                        | 68.20              | -17.76       | PK               |
| Horizontal                         | 4434.07                 | 59.15                        | -20.73                    | 38.42                        | 54.00              | -15.58       | AV               |
| Horizontal                         | 10360.15                | 64.52                        | -9.36                     | 55.16                        | 68.20              | -13.04       | PK               |
| Horizontal                         | 10360.15                | 49.66                        | -9.36                     | 40.30                        | 54.00              | -13.70       | AV               |
| Horizontal                         | 15540.08                | 61.68                        | -7.84                     | 53.84                        | 74.00              | -20.16       | PK               |
| Horizontal                         | 15540.08                | 49.63                        | -7.84                     | 41.79                        | 54.00              | -12.21       | AV               |
| middle Channel (5200 MHz)-Above 1G |                         |                              |                           |                              |                    |              |                  |
| Vertical                           | 4592.08                 | 73.32                        | -20.42                    | 52.91                        | 74.00              | -21.09       | PK               |
| Vertical                           | 4592.08                 | 59.83                        | -20.42                    | 39.41                        | 54.00              | -14.59       | AV               |
| Vertical                           | 10400.16                | 64.85                        | -9.30                     | 55.55                        | 68.20              | -12.65       | PK               |
| Vertical                           | 10400.16                | 49.45                        | -9.30                     | 40.15                        | 54.00              | -13.85       | AV               |
| Vertical                           | 15600.13                | 61.60                        | -7.82                     | 53.78                        | 74.00              | -20.22       | PK               |
| Vertical                           | 15600.13                | 49.59                        | -7.82                     | 41.77                        | 54.00              | -12.23       | AV               |
| Horizontal                         | 4592.05                 | 74.24                        | -20.42                    | 53.82                        | 74.00              | -20.18       | PK               |
| Horizontal                         | 4592.05                 | 59.54                        | -20.42                    | 39.12                        | 54.00              | -14.88       | AV               |
| Horizontal                         | 10400.11                | 61.02                        | -9.30                     | 51.72                        | 68.20              | -16.48       | PK               |
| Horizontal                         | 10400.11                | 49.51                        | -9.30                     | 40.21                        | 54.00              | -13.79       | AV               |
| Horizontal                         | 15600.04                | 60.88                        | -7.82                     | 53.06                        | 74.00              | -20.94       | PK               |
| Horizontal                         | 15600.04                | 49.78                        | -7.82                     | 41.96                        | 54.00              | -12.04       | AV               |
| High Channel (5240 MHz)-Above 1G   |                         |                              |                           |                              |                    |              |                  |
| Vertical                           | 4739.06                 | 74.36                        | -20.12                    | 54.23                        | 74.00              | -19.77       | PK               |
| Vertical                           | 4739.06                 | 59.94                        | -20.12                    | 39.82                        | 54.00              | -14.18       | AV               |
| Vertical                           | 10480.15                | 63.66                        | -9.18                     | 54.48                        | 68.20              | -13.72       | PK               |
| Vertical                           | 10480.15                | 49.25                        | -9.18                     | 40.07                        | 54.00              | -13.93       | AV               |
| Vertical                           | 15720.11                | 63.52                        | -7.78                     | 55.74                        | 74.00              | -18.26       | PK               |
| Vertical                           | 15720.11                | 49.37                        | -7.78                     | 41.59                        | 54.00              | -12.41       | AV               |
| Horizontal                         | 4739.12                 | 71.21                        | -20.12                    | 51.09                        | 74.00              | -22.91       | PK               |
| Horizontal                         | 4739.12                 | 59.19                        | -20.12                    | 39.07                        | 54.00              | -14.93       | AV               |
| Horizontal                         | 10480.05                | 60.79                        | -9.18                     | 51.61                        | 68.20              | -16.59       | PK               |
| Horizontal                         | 10480.05                | 49.35                        | -9.18                     | 40.17                        | 54.00              | -13.83       | AV               |
| Horizontal                         | 15720.11                | 62.86                        | -7.78                     | 55.08                        | 74.00              | -18.92       | PK               |
| Horizontal                         | 15720.11                | 49.20                        | -7.78                     | 41.42                        | 54.00              | -12.58       | AV               |

Note: PK value is lower than the Average value limit, So average didn't record.

The 26.5-40G amplitude of spurious emissions that are attenuated by more than 20dB below the permissible value has no need to be reported.

Emission level (dBuV/m) = 20 log Emission level (uV/m).

Corrected Reading: Antenna Factor + Cable Loss + Read Level - Preamp Factor = Level.

The worst case is Antenna A.

|            |                         |
|------------|-------------------------|
| Test Mode: | TX(5.1G) - 802.11n-HT20 |
|------------|-------------------------|

| Polar<br>(H/V)                     | Fre-<br>quency<br>(MHz) | Reading<br>Level<br>(dBuV/m) | Correct<br>Factor<br>(dB) | Measure-<br>ment<br>(dBuV/m) | Limits<br>(dBuV/m) | Over<br>(dB) | Detector<br>Type |
|------------------------------------|-------------------------|------------------------------|---------------------------|------------------------------|--------------------|--------------|------------------|
| Low Channel (5180 MHz)-Above 1G    |                         |                              |                           |                              |                    |              |                  |
| Vertical                           | 4434.17                 | 73.73                        | -20.73                    | 52.99                        | 68.20              | -15.21       | PK               |
| Vertical                           | 4434.17                 | 59.85                        | -20.73                    | 39.12                        | 54.00              | -14.88       | AV               |
| Vertical                           | 10360.06                | 61.30                        | -9.36                     | 51.94                        | 68.20              | -16.26       | PK               |
| Vertical                           | 10360.06                | 49.60                        | -9.36                     | 40.24                        | 54.00              | -13.76       | AV               |
| Vertical                           | 15540.04                | 61.65                        | -7.84                     | 53.81                        | 74.00              | -20.19       | PK               |
| Vertical                           | 15540.04                | 49.63                        | -7.84                     | 41.79                        | 54.00              | -12.21       | AV               |
| Horizontal                         | 4434.11                 | 73.15                        | -20.73                    | 52.42                        | 68.20              | -15.78       | PK               |
| Horizontal                         | 4434.11                 | 59.93                        | -20.73                    | 39.20                        | 54.00              | -14.80       | AV               |
| Horizontal                         | 10360.03                | 64.53                        | -9.36                     | 55.17                        | 68.20              | -13.03       | PK               |
| Horizontal                         | 10360.03                | 49.41                        | -9.36                     | 40.05                        | 54.00              | -13.95       | AV               |
| Horizontal                         | 15540.10                | 60.60                        | -7.84                     | 52.76                        | 74.00              | -21.24       | PK               |
| Horizontal                         | 15540.10                | 49.20                        | -7.84                     | 41.36                        | 54.00              | -12.64       | AV               |
| middle Channel (5200 MHz)-Above 1G |                         |                              |                           |                              |                    |              |                  |
| Vertical                           | 4592.14                 | 70.76                        | -20.42                    | 50.35                        | 74.00              | -23.65       | PK               |
| Vertical                           | 4592.14                 | 59.23                        | -20.42                    | 38.81                        | 54.00              | -15.19       | AV               |
| Vertical                           | 10400.08                | 63.59                        | -9.30                     | 54.29                        | 68.20              | -13.91       | PK               |
| Vertical                           | 10400.08                | 49.22                        | -9.30                     | 39.92                        | 54.00              | -14.08       | AV               |
| Vertical                           | 15600.07                | 64.98                        | -7.82                     | 57.16                        | 74.00              | -16.84       | PK               |
| Vertical                           | 15600.07                | 49.47                        | -7.82                     | 41.65                        | 54.00              | -12.35       | AV               |
| Horizontal                         | 4592.14                 | 71.62                        | -20.42                    | 51.20                        | 74.00              | -22.80       | PK               |
| Horizontal                         | 4592.14                 | 59.77                        | -20.42                    | 39.35                        | 54.00              | -14.65       | AV               |
| Horizontal                         | 10400.17                | 61.65                        | -9.30                     | 52.35                        | 68.20              | -15.85       | PK               |
| Horizontal                         | 10400.17                | 49.35                        | -9.30                     | 40.05                        | 54.00              | -13.95       | AV               |
| Horizontal                         | 15600.00                | 64.81                        | -7.82                     | 56.99                        | 74.00              | -17.01       | PK               |
| Horizontal                         | 15600.00                | 49.21                        | -7.82                     | 41.39                        | 54.00              | -12.61       | AV               |
| High Channel (5240 MHz)-Above 1G   |                         |                              |                           |                              |                    |              |                  |
| Vertical                           | 4739.15                 | 73.74                        | -20.12                    | 53.62                        | 74.00              | -20.38       | PK               |
| Vertical                           | 4739.15                 | 59.90                        | -20.12                    | 39.78                        | 54.00              | -14.22       | AV               |
| Vertical                           | 10480.17                | 64.55                        | -9.18                     | 55.37                        | 68.20              | -12.83       | PK               |
| Vertical                           | 10480.17                | 49.94                        | -9.18                     | 40.76                        | 54.00              | -13.24       | AV               |
| Vertical                           | 15720.07                | 60.16                        | -7.78                     | 52.38                        | 74.00              | -21.62       | PK               |
| Vertical                           | 15720.07                | 49.65                        | -7.78                     | 41.87                        | 54.00              | -12.13       | AV               |
| Horizontal                         | 4739.14                 | 74.00                        | -20.12                    | 53.88                        | 74.00              | -20.12       | PK               |
| Horizontal                         | 4739.14                 | 59.96                        | -20.12                    | 39.84                        | 54.00              | -14.16       | AV               |
| Horizontal                         | 10480.13                | 63.02                        | -9.18                     | 53.84                        | 68.20              | -14.36       | PK               |
| Horizontal                         | 10480.13                | 49.67                        | -9.18                     | 40.49                        | 54.00              | -13.51       | AV               |
| Horizontal                         | 15720.11                | 63.01                        | -7.78                     | 55.23                        | 74.00              | -18.77       | PK               |
| Horizontal                         | 15720.11                | 49.08                        | -7.78                     | 41.30                        | 54.00              | -12.70       | AV               |

Note: PK value is lower than the Average value limit, So average didn't record.  
 The 26.5-40G amplitude of spurious emissions that are attenuated by more than 20dB below the permissible value has no need to be reported.  
 Emission level (dBuV/m) = 20 log Emission level (uV/m).  
 Corrected Reading: Antenna Factor + Cable Loss + Read Level - Preamp Factor = Level.  
 Test Mode is MIMO Mode.



|            |                         |
|------------|-------------------------|
| Test Mode: | TX(5.1G) - 802.11n-HT40 |
|------------|-------------------------|

| Polar (H/V)                      | Frequency (MHz) | Reading Level (dBuV/m) | Correct Factor (dB) | Measurement (dBuV/m) | Limits (dBuV/m) | Over (dB) | Detector Type |
|----------------------------------|-----------------|------------------------|---------------------|----------------------|-----------------|-----------|---------------|
| Low Channel (5190 MHz)-Above 1G  |                 |                        |                     |                      |                 |           |               |
| Vertical                         | 4434.11         | 70.24                  | -20.73              | 49.51                | 68.20           | -18.69    | PK            |
| Vertical                         | 4434.11         | 59.78                  | -20.73              | 39.05                | 54.00           | -14.95    | AV            |
| Vertical                         | 10380.14        | 64.00                  | -9.33               | 54.67                | 68.20           | -13.53    | PK            |
| Vertical                         | 10380.14        | 49.07                  | -9.33               | 39.74                | 54.00           | -14.26    | AV            |
| Vertical                         | 15570.03        | 61.54                  | -7.83               | 53.71                | 74.00           | -20.29    | PK            |
| Vertical                         | 15570.03        | 49.91                  | -7.83               | 42.08                | 54.00           | -11.92    | AV            |
| Horizontal                       | 4434.03         | 72.09                  | -20.73              | 51.36                | 74.00           | -22.64    | PK            |
| Horizontal                       | 4434.03         | 59.16                  | -20.73              | 38.42                | 54.00           | -15.58    | AV            |
| Horizontal                       | 10380.10        | 61.99                  | -9.33               | 52.66                | 68.20           | -15.54    | PK            |
| Horizontal                       | 10380.10        | 49.33                  | -9.33               | 40.00                | 54.00           | -14.00    | AV            |
| Horizontal                       | 15570.03        | 60.97                  | -7.83               | 53.14                | 74.00           | -20.86    | PK            |
| Horizontal                       | 15570.03        | 49.17                  | -7.83               | 41.34                | 54.00           | -12.66    | AV            |
| High Channel (5230 MHz)-Above 1G |                 |                        |                     |                      |                 |           |               |
| Vertical                         | 4739.07         | 73.20                  | -20.12              | 53.08                | 68.20           | -15.12    | PK            |
| Vertical                         | 4739.07         | 59.95                  | -20.12              | 39.83                | 54.00           | -14.17    | AV            |
| Vertical                         | 10460.07        | 60.07                  | -9.21               | 50.86                | 68.20           | -17.34    | PK            |
| Vertical                         | 10460.07        | 49.40                  | -9.21               | 40.19                | 54.00           | -13.81    | AV            |
| Vertical                         | 15690.14        | 61.44                  | -7.79               | 53.65                | 74.00           | -20.35    | PK            |
| Vertical                         | 15690.14        | 49.29                  | -7.79               | 41.50                | 54.00           | -12.50    | AV            |
| Horizontal                       | 4739.18         | 72.33                  | -20.12              | 52.21                | 68.20           | -15.99    | PK            |
| Horizontal                       | 4739.18         | 59.70                  | -20.12              | 39.58                | 54.00           | -14.42    | AV            |
| Horizontal                       | 10460.20        | 61.22                  | -9.21               | 52.01                | 68.20           | -16.19    | PK            |
| Horizontal                       | 10460.20        | 49.01                  | -9.21               | 39.80                | 54.00           | -14.20    | AV            |
| Horizontal                       | 15690.02        | 64.13                  | -7.79               | 56.34                | 74.00           | -17.66    | PK            |
| Horizontal                       | 15690.02        | 49.51                  | -7.79               | 41.72                | 54.00           | -12.28    | AV            |

Note: PK value is lower than the Average value limit, So average didn't record.  
 The 26.5-40G amplitude of spurious emissions that are attenuated by more than 20dB below the permissible value has no need to be reported.  
 Emission level (dBuV/m) = 20 log Emission level (uV/m).  
 Corrected Reading: Antenna Factor + Cable Loss + Read Level - Preamp Factor = Level.  
 Test Mode is MIMO Mode.

|            |                          |
|------------|--------------------------|
| Test Mode: | TX(5.1G) - 802.11ac-HT20 |
|------------|--------------------------|

| Polar<br>(H/V)                     | Fre-<br>quency<br>(MHz) | Reading<br>Level<br>(dBuV/m) | Correct<br>Factor<br>(dB) | Measure-<br>ment<br>(dBuV/m) | Limits<br>(dBuV/m) | Over<br>(dB) | Detector<br>Type |
|------------------------------------|-------------------------|------------------------------|---------------------------|------------------------------|--------------------|--------------|------------------|
| Low Channel (5180 MHz)-Above 1G    |                         |                              |                           |                              |                    |              |                  |
| Vertical                           | 4434.04                 | 74.18                        | -20.73                    | 53.45                        | 68.20              | -14.75       | PK               |
| Vertical                           | 4434.04                 | 59.57                        | -20.73                    | 38.84                        | 54.00              | -15.16       | AV               |
| Vertical                           | 10360.04                | 63.89                        | -9.36                     | 54.53                        | 68.20              | -13.67       | PK               |
| Vertical                           | 10360.04                | 49.47                        | -9.36                     | 40.11                        | 54.00              | -13.89       | AV               |
| Vertical                           | 15540.17                | 61.63                        | -7.84                     | 53.79                        | 74.00              | -20.21       | PK               |
| Vertical                           | 15540.17                | 49.79                        | -7.84                     | 41.95                        | 54.00              | -12.05       | AV               |
| Horizontal                         | 4434.05                 | 74.18                        | -20.73                    | 53.44                        | 68.20              | -14.76       | PK               |
| Horizontal                         | 4434.05                 | 59.93                        | -20.73                    | 39.20                        | 54.00              | -14.80       | AV               |
| Horizontal                         | 10360.15                | 63.39                        | -9.36                     | 54.03                        | 68.20              | -14.17       | PK               |
| Horizontal                         | 10360.15                | 49.56                        | -9.36                     | 40.20                        | 54.00              | -13.80       | AV               |
| Horizontal                         | 15540.09                | 61.04                        | -7.84                     | 53.20                        | 74.00              | -20.80       | PK               |
| Horizontal                         | 15540.09                | 49.61                        | -7.84                     | 41.77                        | 54.00              | -12.23       | AV               |
| middle Channel (5200 MHz)-Above 1G |                         |                              |                           |                              |                    |              |                  |
| Vertical                           | 4592.19                 | 71.31                        | -20.42                    | 50.89                        | 74.00              | -23.11       | PK               |
| Vertical                           | 4592.19                 | 59.36                        | -20.42                    | 38.95                        | 54.00              | -15.05       | AV               |
| Vertical                           | 10400.00                | 60.53                        | -9.30                     | 51.23                        | 68.20              | -16.97       | PK               |
| Vertical                           | 10400.00                | 49.65                        | -9.30                     | 40.35                        | 54.00              | -13.65       | AV               |
| Vertical                           | 15600.07                | 60.04                        | -7.82                     | 52.22                        | 74.00              | -21.78       | PK               |
| Vertical                           | 15600.07                | 49.78                        | -7.82                     | 41.96                        | 54.00              | -12.04       | AV               |
| Horizontal                         | 4592.14                 | 70.97                        | -20.42                    | 50.55                        | 74.00              | -23.45       | PK               |
| Horizontal                         | 4592.14                 | 59.89                        | -20.42                    | 39.47                        | 54.00              | -14.53       | AV               |
| Horizontal                         | 10400.16                | 63.77                        | -9.30                     | 54.47                        | 68.20              | -13.73       | PK               |
| Horizontal                         | 10400.16                | 49.06                        | -9.30                     | 39.76                        | 54.00              | -14.24       | AV               |
| Horizontal                         | 15600.02                | 64.92                        | -7.82                     | 57.10                        | 74.00              | -16.90       | PK               |
| Horizontal                         | 15600.02                | 49.15                        | -7.82                     | 41.33                        | 54.00              | -12.67       | AV               |
| High Channel (5240 MHz)-Above 1G   |                         |                              |                           |                              |                    |              |                  |
| Vertical                           | 4739.16                 | 70.25                        | -20.12                    | 50.13                        | 74.00              | -23.87       | PK               |
| Vertical                           | 4739.16                 | 59.05                        | -20.12                    | 38.93                        | 54.00              | -15.07       | AV               |
| Vertical                           | 10480.15                | 60.80                        | -9.18                     | 51.62                        | 68.20              | -16.58       | PK               |
| Vertical                           | 10480.15                | 49.64                        | -9.18                     | 40.46                        | 54.00              | -13.54       | AV               |
| Vertical                           | 15720.12                | 63.30                        | -7.78                     | 55.52                        | 74.00              | -18.48       | PK               |
| Vertical                           | 15720.12                | 49.65                        | -7.78                     | 41.87                        | 54.00              | -12.13       | AV               |
| Horizontal                         | 4739.15                 | 74.02                        | -20.12                    | 53.90                        | 74.00              | -20.10       | PK               |
| Horizontal                         | 4739.15                 | 59.52                        | -20.12                    | 39.39                        | 54.00              | -14.61       | AV               |
| Horizontal                         | 10480.00                | 62.51                        | -9.18                     | 53.33                        | 68.20              | -14.87       | PK               |
| Horizontal                         | 10480.00                | 49.88                        | -9.18                     | 40.70                        | 54.00              | -13.30       | AV               |
| Horizontal                         | 15720.03                | 63.45                        | -7.78                     | 55.67                        | 74.00              | -18.33       | PK               |
| Horizontal                         | 15720.03                | 49.59                        | -7.78                     | 41.81                        | 54.00              | -12.19       | AV               |

Note: PK value is lower than the Average value limit, So average didn't record.  
 The 26.5-40G amplitude of spurious emissions that are attenuated by more than 20dB below the permissible value has no need to be reported.  
 Emission level (dBuV/m) = 20 log Emission level (uV/m).  
 Corrected Reading: Antenna Factor + Cable Loss + Read Level - Preamp Factor = Level.  
 Test Mode is MIMO Mode.

|            |                          |
|------------|--------------------------|
| Test Mode: | TX(5.1G) - 802.11ac-HT40 |
|------------|--------------------------|

| Polar<br>(H/V)                   | Fre-<br>quency<br>(MHz) | Reading<br>Level<br>(dBuV/m) | Correct<br>Factor<br>(dB) | Measure-<br>ment<br>(dBuV/m) | Limits<br>(dBuV/m) | Over<br>(dB) | Detector<br>Type |
|----------------------------------|-------------------------|------------------------------|---------------------------|------------------------------|--------------------|--------------|------------------|
| Low Channel (5190 MHz)-Above 1G  |                         |                              |                           |                              |                    |              |                  |
| Vertical                         | 4434.02                 | 72.22                        | -20.73                    | 51.49                        | 68.20              | -16.71       | PK               |
| Vertical                         | 4434.02                 | 59.73                        | -20.73                    | 38.99                        | 54.00              | -15.01       | AV               |
| Vertical                         | 10380.18                | 61.06                        | -9.33                     | 51.73                        | 68.20              | -16.47       | PK               |
| Vertical                         | 10380.18                | 49.17                        | -9.33                     | 39.84                        | 54.00              | -14.16       | AV               |
| Vertical                         | 15570.02                | 62.27                        | -7.83                     | 54.44                        | 74.00              | -19.56       | PK               |
| Vertical                         | 15570.02                | 49.86                        | -7.83                     | 42.03                        | 54.00              | -11.97       | AV               |
| Horizontal                       | 4434.09                 | 73.11                        | -20.73                    | 52.38                        | 74.00              | -21.62       | PK               |
| Horizontal                       | 4434.09                 | 59.89                        | -20.73                    | 39.15                        | 54.00              | -14.85       | AV               |
| Horizontal                       | 10380.02                | 64.85                        | -9.33                     | 55.52                        | 68.20              | -12.68       | PK               |
| Horizontal                       | 10380.02                | 49.85                        | -9.33                     | 40.52                        | 54.00              | -13.48       | AV               |
| Horizontal                       | 15570.11                | 63.67                        | -7.83                     | 55.84                        | 74.00              | -18.16       | PK               |
| Horizontal                       | 15570.11                | 49.45                        | -7.83                     | 41.62                        | 54.00              | -12.38       | AV               |
| High Channel (5230 MHz)-Above 1G |                         |                              |                           |                              |                    |              |                  |
| Vertical                         | 4739.11                 | 74.65                        | -20.12                    | 54.52                        | 68.20              | -13.68       | PK               |
| Vertical                         | 4739.11                 | 59.04                        | -20.12                    | 38.92                        | 54.00              | -15.08       | AV               |
| Vertical                         | 10460.20                | 62.80                        | -9.21                     | 53.59                        | 68.20              | -14.61       | PK               |
| Vertical                         | 10460.20                | 49.45                        | -9.21                     | 40.24                        | 54.00              | -13.76       | AV               |
| Vertical                         | 15690.03                | 64.58                        | -7.79                     | 56.79                        | 74.00              | -17.21       | PK               |
| Vertical                         | 15690.03                | 49.78                        | -7.79                     | 41.99                        | 54.00              | -12.01       | AV               |
| Horizontal                       | 4739.18                 | 73.70                        | -20.12                    | 53.58                        | 68.20              | -14.62       | PK               |
| Horizontal                       | 4739.18                 | 59.21                        | -20.12                    | 39.09                        | 54.00              | -14.91       | AV               |
| Horizontal                       | 10460.16                | 62.52                        | -9.21                     | 53.31                        | 68.20              | -14.89       | PK               |
| Horizontal                       | 10460.16                | 49.26                        | -9.21                     | 40.05                        | 54.00              | -13.95       | AV               |
| Horizontal                       | 15690.18                | 63.66                        | -7.79                     | 55.87                        | 74.00              | -18.13       | PK               |
| Horizontal                       | 15690.18                | 49.06                        | -7.79                     | 41.27                        | 54.00              | -12.73       | AV               |

Note: PK value is lower than the Average value limit, So average didn't record.  
 The 26.5-40G amplitude of spurious emissions that are attenuated by more than 20dB below the permissible value has no need to be reported.  
 Emission level (dBuV/m) = 20 log Emission level (uV/m).  
 Corrected Reading: Antenna Factor + Cable Loss + Read Level - Preamp Factor = Level.  
 Test Mode is MIMO Mode.

|            |                          |
|------------|--------------------------|
| Test Mode: | TX(5.1G) - 802.11ac-HT80 |
|------------|--------------------------|

| Polar<br>(H/V)      | Fre-<br>quency<br>(MHz) | Reading<br>Level<br>(dBuV/m) | Correct<br>Factor<br>(dB) | Measure-<br>ment<br>(dBuV/m) | Limits<br>(dBuV/m) | Over<br>(dB) | Detector<br>Type |
|---------------------|-------------------------|------------------------------|---------------------------|------------------------------|--------------------|--------------|------------------|
| (5210 MHz)-Above 1G |                         |                              |                           |                              |                    |              |                  |
| Vertical            | 4434.06                 | 72.71                        | -20.73                    | 51.98                        | 68.20              | -16.22       | PK               |
| Vertical            | 4434.06                 | 59.72                        | -20.73                    | 38.99                        | 54.00              | -15.01       | AV               |
| Vertical            | 10420.06                | 63.89                        | -9.27                     | 54.62                        | 68.20              | -13.58       | PK               |
| Vertical            | 10420.06                | 49.37                        | -9.27                     | 40.10                        | 54.00              | -13.90       | AV               |
| Vertical            | 15630.17                | 61.73                        | -7.81                     | 53.92                        | 74.00              | -20.08       | PK               |
| Vertical            | 15630.17                | 49.32                        | -7.81                     | 41.51                        | 54.00              | -12.49       | AV               |
| Horizontal          | 4434.14                 | 73.38                        | -20.73                    | 52.65                        | 68.20              | -15.55       | PK               |
| Horizontal          | 4434.14                 | 49.76                        | -20.73                    | 29.02                        | 54.00              | -24.98       | AV               |
| Horizontal          | 10420.20                | 44.63                        | 9.27                      | 53.90                        | 68.20              | -14.30       | PK               |
| Horizontal          | 10420.20                | 29.62                        | 9.27                      | 38.89                        | 54.00              | -15.11       | AV               |
| Horizontal          | 15630.12                | 62.63                        | -7.81                     | 54.82                        | 74.00              | -19.18       | PK               |
| Horizontal          | 15630.12                | 49.35                        | -7.81                     | 41.54                        | 54.00              | -12.46       | AV               |

Note: PK value is lower than the Average value limit, So average didn't record.  
 The 26.5-40G amplitude of spurious emissions that are attenuated by more than 20dB below the permissible value has no need to be reported.  
 Emission level (dBuV/m) = 20 log Emission level (uV/m).  
 Corrected Reading: Antenna Factor + Cable Loss + Read Level - Preamp Factor = Level.  
 Test Mode is MIMO Mode.

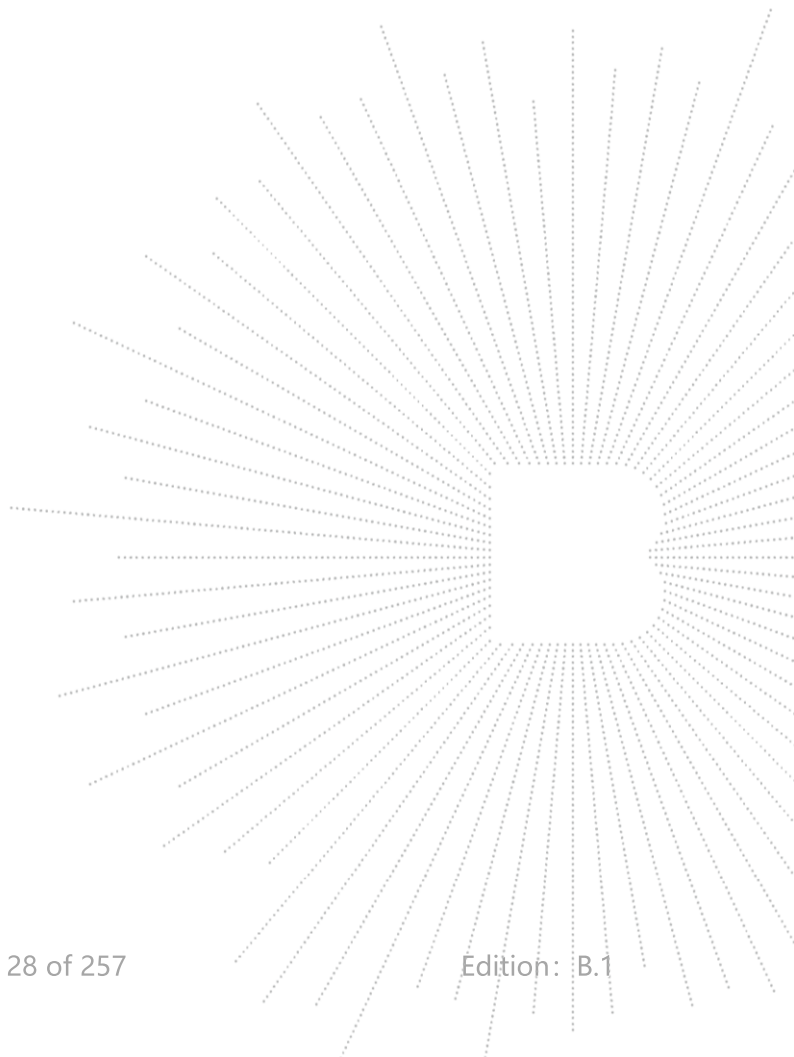

|            |                    |
|------------|--------------------|
| Test Mode: | TX(5.3G) - 802.11a |
|------------|--------------------|

| Polar<br>(H/V)                     | Fre-<br>quency<br>(MHz) | Reading<br>Level<br>(dBuV/m) | Correct<br>Factor<br>(dB) | Measure-<br>ment<br>(dBuV/m) | Limits<br>(dBuV/m) | Over<br>(dB) | Detector<br>Type |
|------------------------------------|-------------------------|------------------------------|---------------------------|------------------------------|--------------------|--------------|------------------|
| Low Channel (5260 MHz)-Above 1G    |                         |                              |                           |                              |                    |              |                  |
| Vertical                           | 4434.20                 | 71.32                        | -20.73                    | 50.59                        | 68.20              | -17.61       | PK               |
| Vertical                           | 4434.20                 | 59.20                        | -20.73                    | 38.46                        | 54.00              | -15.54       | AV               |
| Vertical                           | 10520.05                | 62.86                        | -9.12                     | 53.74                        | 68.20              | -14.46       | PK               |
| Vertical                           | 10520.05                | 49.73                        | -9.12                     | 40.61                        | 54.00              | -13.39       | AV               |
| Vertical                           | 15780.18                | 61.01                        | -7.77                     | 53.24                        | 74.00              | -20.76       | PK               |
| Vertical                           | 15780.18                | 49.33                        | -7.77                     | 41.56                        | 54.00              | -12.44       | AV               |
| Horizontal                         | 4434.16                 | 74.09                        | -20.73                    | 53.36                        | 68.20              | -14.84       | PK               |
| Horizontal                         | 4434.16                 | 59.00                        | -20.73                    | 38.27                        | 54.00              | -15.73       | AV               |
| Horizontal                         | 10520.03                | 61.91                        | -9.12                     | 52.79                        | 68.20              | -15.41       | PK               |
| Horizontal                         | 10520.03                | 49.56                        | -9.12                     | 40.44                        | 54.00              | -13.56       | AV               |
| Horizontal                         | 15780.17                | 61.66                        | -7.77                     | 53.89                        | 74.00              | -20.11       | PK               |
| Horizontal                         | 15780.17                | 49.74                        | -7.77                     | 41.97                        | 54.00              | -12.03       | AV               |
| middle Channel (5280 MHz)-Above 1G |                         |                              |                           |                              |                    |              |                  |
| Vertical                           | 4592.00                 | 73.43                        | -20.42                    | 53.02                        | 74.00              | -20.98       | PK               |
| Vertical                           | 4592.00                 | 59.80                        | -20.42                    | 39.38                        | 54.00              | -14.62       | AV               |
| Vertical                           | 10560.02                | 60.92                        | -9.06                     | 51.86                        | 68.20              | -16.34       | PK               |
| Vertical                           | 10560.02                | 49.35                        | -9.06                     | 40.29                        | 54.00              | -13.71       | AV               |
| Vertical                           | 15840.14                | 63.62                        | -7.75                     | 55.87                        | 74.00              | -18.13       | PK               |
| Vertical                           | 15840.14                | 49.37                        | -7.75                     | 41.62                        | 54.00              | -12.38       | AV               |
| Horizontal                         | 4592.19                 | 70.66                        | -20.42                    | 50.25                        | 74.00              | -23.75       | PK               |
| Horizontal                         | 4592.19                 | 59.20                        | -20.42                    | 38.78                        | 54.00              | -15.22       | AV               |
| Horizontal                         | 10560.00                | 64.82                        | -9.06                     | 55.76                        | 68.20              | -12.44       | PK               |
| Horizontal                         | 10560.00                | 49.58                        | -9.06                     | 40.52                        | 54.00              | -13.48       | AV               |
| Horizontal                         | 15840.03                | 63.24                        | -7.75                     | 55.49                        | 74.00              | -18.51       | PK               |
| Horizontal                         | 15840.03                | 49.58                        | -7.75                     | 41.83                        | 54.00              | -12.17       | AV               |
| High Channel (5320 MHz)-Above 1G   |                         |                              |                           |                              |                    |              |                  |
| Vertical                           | 4739.15                 | 72.40                        | -20.12                    | 52.28                        | 74.00              | -21.72       | PK               |
| Vertical                           | 4739.15                 | 59.01                        | -20.12                    | 38.89                        | 54.00              | -15.11       | AV               |
| Vertical                           | 10640.20                | 62.30                        | -8.94                     | 53.36                        | 68.20              | -14.84       | PK               |
| Vertical                           | 10640.20                | 49.81                        | -8.94                     | 40.87                        | 54.00              | -13.13       | AV               |
| Vertical                           | 15960.10                | 63.05                        | -7.71                     | 55.34                        | 74.00              | -18.66       | PK               |
| Vertical                           | 15960.10                | 49.09                        | -7.71                     | 41.38                        | 54.00              | -12.62       | AV               |
| Horizontal                         | 4739.05                 | 70.77                        | -20.12                    | 50.64                        | 74.00              | -23.36       | PK               |
| Horizontal                         | 4739.05                 | 59.77                        | -20.12                    | 39.65                        | 54.00              | -14.35       | AV               |
| Horizontal                         | 10640.18                | 64.39                        | -8.94                     | 55.45                        | 68.20              | -12.75       | PK               |
| Horizontal                         | 10640.18                | 49.69                        | -8.94                     | 40.75                        | 54.00              | -13.25       | AV               |
| Horizontal                         | 15960.14                | 63.96                        | -7.71                     | 56.25                        | 74.00              | -17.75       | PK               |
| Horizontal                         | 15960.14                | 49.73                        | -7.71                     | 42.02                        | 54.00              | -11.98       | AV               |

Note: PK value is lower than the Average value limit, So average didn't record.  
 The 26.5-40G amplitude of spurious emissions that are attenuated by more than 20dB below the permissible value has no need to be reported.  
 Emission level (dBuV/m) = 20 log Emission level (uV/m).  
 Corrected Reading: Antenna Factor + Cable Loss + Read Level - Preamp Factor = Level.  
 The worst case is Antenna A.

|            |                         |
|------------|-------------------------|
| Test Mode: | TX(5.3G) - 802.11n-HT20 |
|------------|-------------------------|

| Polar<br>(H/V)                     | Fre-<br>quency<br>(MHz) | Reading<br>Level<br>(dBuV/m) | Correct<br>Factor<br>(dB) | Measure-<br>ment<br>(dBuV/m) | Limits<br>(dBuV/m) | Over<br>(dB) | Detector<br>Type |
|------------------------------------|-------------------------|------------------------------|---------------------------|------------------------------|--------------------|--------------|------------------|
| Low Channel (5260 MHz)-Above 1G    |                         |                              |                           |                              |                    |              |                  |
| Vertical                           | 4434.01                 | 71.64                        | -20.73                    | 50.90                        | 68.20              | -17.30       | PK               |
| Vertical                           | 4434.01                 | 59.75                        | -20.73                    | 39.02                        | 54.00              | -14.98       | AV               |
| Vertical                           | 10520.19                | 63.48                        | -9.12                     | 54.36                        | 68.20              | -13.84       | PK               |
| Vertical                           | 10520.19                | 49.61                        | -9.12                     | 40.49                        | 54.00              | -13.51       | AV               |
| Vertical                           | 15780.18                | 63.06                        | -7.77                     | 55.29                        | 74.00              | -18.71       | PK               |
| Vertical                           | 15780.18                | 49.08                        | -7.77                     | 41.31                        | 54.00              | -12.69       | AV               |
| Horizontal                         | 4434.03                 | 73.67                        | -20.73                    | 52.94                        | 68.20              | -15.26       | PK               |
| Horizontal                         | 4434.03                 | 59.23                        | -20.73                    | 38.50                        | 54.00              | -15.50       | AV               |
| Horizontal                         | 10520.03                | 63.76                        | -9.12                     | 54.64                        | 68.20              | -13.56       | PK               |
| Horizontal                         | 10520.03                | 49.89                        | -9.12                     | 40.77                        | 54.00              | -13.23       | AV               |
| Horizontal                         | 15780.02                | 60.74                        | -7.77                     | 52.97                        | 74.00              | -21.03       | PK               |
| Horizontal                         | 15780.02                | 49.12                        | -7.77                     | 41.35                        | 54.00              | -12.65       | AV               |
| middle Channel (5280 MHz)-Above 1G |                         |                              |                           |                              |                    |              |                  |
| Vertical                           | 4592.02                 | 72.72                        | -20.42                    | 52.31                        | 74.00              | -21.69       | PK               |
| Vertical                           | 4592.02                 | 59.43                        | -20.42                    | 39.02                        | 54.00              | -14.98       | AV               |
| Vertical                           | 10560.13                | 62.43                        | -9.06                     | 53.37                        | 68.20              | -14.83       | PK               |
| Vertical                           | 10560.13                | 49.09                        | -9.06                     | 40.03                        | 54.00              | -13.97       | AV               |
| Vertical                           | 15840.02                | 62.18                        | -7.75                     | 54.43                        | 74.00              | -19.57       | PK               |
| Vertical                           | 15840.02                | 49.61                        | -7.75                     | 41.86                        | 54.00              | -12.14       | AV               |
| Horizontal                         | 4592.18                 | 71.47                        | -20.42                    | 51.06                        | 74.00              | -22.94       | PK               |
| Horizontal                         | 4592.18                 | 59.88                        | -20.42                    | 39.47                        | 54.00              | -14.53       | AV               |
| Horizontal                         | 10560.10                | 62.85                        | -9.06                     | 53.79                        | 68.20              | -14.41       | PK               |
| Horizontal                         | 10560.10                | 49.81                        | -9.06                     | 40.75                        | 54.00              | -13.25       | AV               |
| Horizontal                         | 15840.04                | 60.26                        | -7.75                     | 52.51                        | 74.00              | -21.49       | PK               |
| Horizontal                         | 15840.04                | 49.41                        | -7.75                     | 41.66                        | 54.00              | -12.34       | AV               |
| High Channel (5320 MHz)-Above 1G   |                         |                              |                           |                              |                    |              |                  |
| Vertical                           | 4739.20                 | 73.92                        | -20.12                    | 53.80                        | 74.00              | -20.20       | PK               |
| Vertical                           | 4739.20                 | 59.10                        | -20.12                    | 38.97                        | 54.00              | -15.03       | AV               |
| Vertical                           | 10640.16                | 62.81                        | -8.94                     | 53.87                        | 68.20              | -14.33       | PK               |
| Vertical                           | 10640.16                | 49.73                        | -8.94                     | 40.79                        | 54.00              | -13.21       | AV               |
| Vertical                           | 15960.09                | 62.02                        | -7.71                     | 54.31                        | 74.00              | -19.69       | PK               |
| Vertical                           | 15960.09                | 49.08                        | -7.71                     | 41.37                        | 54.00              | -12.63       | AV               |
| Horizontal                         | 4739.11                 | 73.94                        | -20.12                    | 53.82                        | 74.00              | -20.18       | PK               |
| Horizontal                         | 4739.11                 | 59.53                        | -20.12                    | 39.41                        | 54.00              | -14.59       | AV               |
| Horizontal                         | 10640.19                | 63.77                        | -8.94                     | 54.83                        | 68.20              | -13.37       | PK               |
| Horizontal                         | 10640.19                | 49.17                        | -8.94                     | 40.23                        | 54.00              | -13.77       | AV               |
| Horizontal                         | 15960.05                | 63.59                        | -7.71                     | 55.88                        | 74.00              | -18.12       | PK               |
| Horizontal                         | 15960.05                | 49.37                        | -7.71                     | 41.66                        | 54.00              | -12.34       | AV               |

Note: PK value is lower than the Average value limit, So average didn't record.  
 The 26.5-40G amplitude of spurious emissions that are attenuated by more than 20dB below the permissible value has no need to be reported.  
 Emission level (dBuV/m) = 20 log Emission level (uV/m).  
 Corrected Reading: Antenna Factor + Cable Loss + Read Level - Preamp Factor = Level.  
 Test Mode is MIMO Mode.

|            |                         |
|------------|-------------------------|
| Test Mode: | TX(5.3G) - 802.11n-HT40 |
|------------|-------------------------|

| Polar<br>(H/V)                   | Fre-<br>quency<br>(MHz) | Reading<br>Level<br>(dBuV/m) | Correct<br>Factor<br>(dB) | Measure-<br>ment<br>(dBuV/m) | Limits<br>(dBuV/m) | Over<br>(dB) | Detector<br>Type |
|----------------------------------|-------------------------|------------------------------|---------------------------|------------------------------|--------------------|--------------|------------------|
| Low Channel (5270 MHz)-Above 1G  |                         |                              |                           |                              |                    |              |                  |
| Vertical                         | 4434.15                 | 74.97                        | -20.73                    | 54.24                        | 68.20              | -13.96       | PK               |
| Vertical                         | 4434.15                 | 59.19                        | -20.73                    | 38.46                        | 54.00              | -15.54       | AV               |
| Vertical                         | 10540.08                | 61.46                        | -9.09                     | 52.37                        | 68.20              | -15.83       | PK               |
| Vertical                         | 10540.08                | 49.15                        | -9.09                     | 40.06                        | 54.00              | -13.94       | AV               |
| Vertical                         | 15810.07                | 64.92                        | -7.76                     | 57.16                        | 74.00              | -16.84       | PK               |
| Vertical                         | 15810.07                | 49.62                        | -7.76                     | 41.86                        | 54.00              | -12.14       | AV               |
| Horizontal                       | 4434.04                 | 74.98                        | -20.73                    | 54.25                        | 74.00              | -19.75       | PK               |
| Horizontal                       | 4434.04                 | 59.43                        | -20.73                    | 38.70                        | 54.00              | -15.30       | AV               |
| Horizontal                       | 10540.18                | 60.69                        | -9.09                     | 51.60                        | 68.20              | -16.60       | PK               |
| Horizontal                       | 10540.18                | 49.41                        | -9.09                     | 40.32                        | 54.00              | -13.68       | AV               |
| Horizontal                       | 15810.00                | 61.52                        | -7.76                     | 53.76                        | 74.00              | -20.24       | PK               |
| Horizontal                       | 15810.00                | 49.53                        | -7.76                     | 41.77                        | 54.00              | -12.23       | AV               |
| High Channel (5310 MHz)-Above 1G |                         |                              |                           |                              |                    |              |                  |
| Vertical                         | 4739.02                 | 72.99                        | -20.12                    | 52.87                        | 68.20              | -15.33       | PK               |
| Vertical                         | 4739.02                 | 59.96                        | -20.12                    | 39.83                        | 54.00              | -14.17       | AV               |
| Vertical                         | 10620.04                | 64.97                        | -8.97                     | 56.00                        | 68.20              | -12.20       | PK               |
| Vertical                         | 10620.04                | 49.86                        | -8.97                     | 40.89                        | 54.00              | -13.11       | AV               |
| Vertical                         | 15930.13                | 64.55                        | -7.72                     | 56.83                        | 74.00              | -17.17       | PK               |
| Vertical                         | 15930.13                | 49.99                        | -7.72                     | 42.27                        | 54.00              | -11.73       | AV               |
| Horizontal                       | 4739.06                 | 71.52                        | -20.12                    | 51.40                        | 68.20              | -16.80       | PK               |
| Horizontal                       | 4739.06                 | 59.23                        | -20.12                    | 39.11                        | 54.00              | -14.89       | AV               |
| Horizontal                       | 10620.13                | 64.01                        | -8.97                     | 55.04                        | 68.20              | -13.16       | PK               |
| Horizontal                       | 10620.13                | 49.30                        | -8.97                     | 40.33                        | 54.00              | -13.67       | AV               |
| Horizontal                       | 15930.13                | 63.39                        | -7.72                     | 55.67                        | 74.00              | -18.33       | PK               |
| Horizontal                       | 15930.13                | 49.35                        | -7.72                     | 41.63                        | 54.00              | -12.37       | AV               |

Note: PK value is lower than the Average value limit, So average didn't record.  
 The 26.5-40G amplitude of spurious emissions that are attenuated by more than 20dB below the permissible value has no need to be reported.  
 Emission level (dBuV/m) = 20 log Emission level (uV/m).  
 Corrected Reading: Antenna Factor + Cable Loss + Read Level - Preamp Factor = Level.  
 Test Mode is MIMO Mode.

|            |                          |
|------------|--------------------------|
| Test Mode: | TX(5.3G) - 802.11ac-HT20 |
|------------|--------------------------|

| Polar<br>(H/V)                     | Fre-<br>quency<br>(MHz) | Reading<br>Level<br>(dBuV/m) | Correct<br>Factor<br>(dB) | Measure-<br>ment<br>(dBuV/m) | Limits<br>(dBuV/m) | Over<br>(dB) | Detector<br>Type |
|------------------------------------|-------------------------|------------------------------|---------------------------|------------------------------|--------------------|--------------|------------------|
| Low Channel (5260 MHz)-Above 1G    |                         |                              |                           |                              |                    |              |                  |
| Vertical                           | 4434.16                 | 72.88                        | -20.73                    | 52.15                        | 68.20              | -16.05       | PK               |
| Vertical                           | 4434.16                 | 59.96                        | -20.73                    | 39.23                        | 54.00              | -14.77       | AV               |
| Vertical                           | 10520.16                | 60.55                        | -9.12                     | 51.43                        | 68.20              | -16.77       | PK               |
| Vertical                           | 10520.16                | 49.58                        | -9.12                     | 40.46                        | 54.00              | -13.54       | AV               |
| Vertical                           | 15780.16                | 64.65                        | -7.77                     | 56.88                        | 74.00              | -17.12       | PK               |
| Vertical                           | 15780.16                | 49.93                        | -7.77                     | 42.16                        | 54.00              | -11.84       | AV               |
| Horizontal                         | 4434.06                 | 70.21                        | -20.73                    | 49.48                        | 68.20              | -18.72       | PK               |
| Horizontal                         | 4434.06                 | 59.48                        | -20.73                    | 38.74                        | 54.00              | -15.26       | AV               |
| Horizontal                         | 10520.17                | 61.35                        | -9.12                     | 52.23                        | 68.20              | -15.97       | PK               |
| Horizontal                         | 10520.17                | 49.49                        | -9.12                     | 40.37                        | 54.00              | -13.63       | AV               |
| Horizontal                         | 15780.01                | 60.71                        | -7.77                     | 52.94                        | 74.00              | -21.06       | PK               |
| Horizontal                         | 15780.01                | 49.02                        | -7.77                     | 41.25                        | 54.00              | -12.75       | AV               |
| middle Channel (5280 MHz)-Above 1G |                         |                              |                           |                              |                    |              |                  |
| Vertical                           | 4592.01                 | 72.38                        | -20.42                    | 51.96                        | 74.00              | -22.04       | PK               |
| Vertical                           | 4592.01                 | 59.49                        | -20.42                    | 39.08                        | 54.00              | -14.92       | AV               |
| Vertical                           | 10560.06                | 63.41                        | -9.06                     | 54.35                        | 68.20              | -13.85       | PK               |
| Vertical                           | 10560.06                | 49.15                        | -9.06                     | 40.09                        | 54.00              | -13.91       | AV               |
| Vertical                           | 15840.12                | 62.87                        | -7.75                     | 55.12                        | 74.00              | -18.88       | PK               |
| Vertical                           | 15840.12                | 49.26                        | -7.75                     | 41.51                        | 54.00              | -12.49       | AV               |
| Horizontal                         | 4592.13                 | 71.06                        | -20.42                    | 50.65                        | 74.00              | -23.35       | PK               |
| Horizontal                         | 4592.13                 | 59.23                        | -20.42                    | 38.81                        | 54.00              | -15.19       | AV               |
| Horizontal                         | 10560.05                | 61.62                        | -9.06                     | 52.56                        | 68.20              | -15.64       | PK               |
| Horizontal                         | 10560.05                | 49.37                        | -9.06                     | 40.31                        | 54.00              | -13.69       | AV               |
| Horizontal                         | 15840.05                | 62.45                        | -7.75                     | 54.70                        | 74.00              | -19.30       | PK               |
| Horizontal                         | 15840.05                | 49.34                        | -7.75                     | 41.59                        | 54.00              | -12.41       | AV               |
| High Channel (5320 MHz)-Above 1G   |                         |                              |                           |                              |                    |              |                  |
| Vertical                           | 4739.07                 | 73.03                        | -20.12                    | 52.91                        | 74.00              | -21.09       | PK               |
| Vertical                           | 4739.07                 | 59.39                        | -20.12                    | 39.27                        | 54.00              | -14.73       | AV               |
| Vertical                           | 10640.14                | 60.28                        | -8.94                     | 51.34                        | 68.20              | -16.86       | PK               |
| Vertical                           | 10640.14                | 49.21                        | -8.94                     | 40.27                        | 54.00              | -13.73       | AV               |
| Vertical                           | 15960.10                | 64.83                        | -7.71                     | 57.12                        | 74.00              | -16.88       | PK               |
| Vertical                           | 15960.10                | 49.79                        | -7.71                     | 42.08                        | 54.00              | -11.92       | AV               |
| Horizontal                         | 4739.12                 | 74.40                        | -20.12                    | 54.27                        | 74.00              | -19.73       | PK               |
| Horizontal                         | 4739.12                 | 59.57                        | -20.12                    | 39.45                        | 54.00              | -14.55       | AV               |
| Horizontal                         | 10640.15                | 60.08                        | -8.94                     | 51.14                        | 68.20              | -17.06       | PK               |
| Horizontal                         | 10640.15                | 49.21                        | -8.94                     | 40.27                        | 54.00              | -13.73       | AV               |
| Horizontal                         | 15960.07                | 62.91                        | -7.71                     | 55.20                        | 74.00              | -18.80       | PK               |
| Horizontal                         | 15960.07                | 49.13                        | -7.71                     | 41.42                        | 54.00              | -12.58       | AV               |

Note: PK value is lower than the Average value limit, So average didn't record.  
 The 26.5-40G amplitude of spurious emissions that are attenuated by more than 20dB below the permissible value has no need to be reported.  
 Emission level (dBuV/m) = 20 log Emission level (uV/m).  
 Corrected Reading: Antenna Factor + Cable Loss + Read Level - Preamp Factor = Level.  
 Test Mode is MIMO Mode.



|            |                          |
|------------|--------------------------|
| Test Mode: | TX(5.3G) - 802.11ac-HT40 |
|------------|--------------------------|

| Polar<br>(H/V)                   | Fre-<br>quency<br>(MHz) | Reading<br>Level<br>(dBuV/m) | Correct<br>Factor<br>(dB) | Measure-<br>ment<br>(dBuV/m) | Limits<br>(dBuV/m) | Over<br>(dB) | Detector<br>Type |
|----------------------------------|-------------------------|------------------------------|---------------------------|------------------------------|--------------------|--------------|------------------|
| Low Channel (5270 MHz)-Above 1G  |                         |                              |                           |                              |                    |              |                  |
| Vertical                         | 4434.17                 | 72.01                        | -20.73                    | 51.27                        | 68.20              | -16.93       | PK               |
| Vertical                         | 4434.17                 | 59.58                        | -20.73                    | 38.85                        | 54.00              | -15.15       | AV               |
| Vertical                         | 10540.09                | 62.72                        | -9.09                     | 53.63                        | 68.20              | -14.57       | PK               |
| Vertical                         | 10540.09                | 49.09                        | -9.09                     | 40.00                        | 54.00              | -14.00       | AV               |
| Vertical                         | 15810.11                | 64.36                        | -7.76                     | 56.60                        | 74.00              | -17.40       | PK               |
| Vertical                         | 15810.11                | 49.66                        | -7.76                     | 41.90                        | 54.00              | -12.10       | AV               |
| Horizontal                       | 4434.01                 | 73.36                        | -20.73                    | 52.63                        | 74.00              | -21.37       | PK               |
| Horizontal                       | 4434.01                 | 59.90                        | -20.73                    | 39.17                        | 54.00              | -14.83       | AV               |
| Horizontal                       | 10540.11                | 60.77                        | -9.09                     | 51.68                        | 68.20              | -16.52       | PK               |
| Horizontal                       | 10540.11                | 49.51                        | -9.09                     | 40.42                        | 54.00              | -13.58       | AV               |
| Horizontal                       | 15810.19                | 60.05                        | -7.76                     | 52.29                        | 74.00              | -21.71       | PK               |
| Horizontal                       | 15810.19                | 49.07                        | -7.76                     | 41.31                        | 54.00              | -12.69       | AV               |
| High Channel (5310 MHz)-Above 1G |                         |                              |                           |                              |                    |              |                  |
| Vertical                         | 4739.10                 | 72.35                        | -20.12                    | 52.23                        | 68.20              | -15.97       | PK               |
| Vertical                         | 4739.10                 | 59.83                        | -20.12                    | 39.71                        | 54.00              | -14.29       | AV               |
| Vertical                         | 10620.10                | 63.14                        | -8.97                     | 54.17                        | 68.20              | -14.03       | PK               |
| Vertical                         | 10620.10                | 49.04                        | -8.97                     | 40.07                        | 54.00              | -13.93       | AV               |
| Vertical                         | 15930.07                | 62.81                        | -7.72                     | 55.09                        | 74.00              | -18.91       | PK               |
| Vertical                         | 15930.07                | 49.82                        | -7.72                     | 42.10                        | 54.00              | -11.90       | AV               |
| Horizontal                       | 4739.14                 | 71.63                        | -20.12                    | 51.51                        | 68.20              | -16.69       | PK               |
| Horizontal                       | 4739.14                 | 59.85                        | -20.12                    | 39.72                        | 54.00              | -14.28       | AV               |
| Horizontal                       | 10620.19                | 61.62                        | -8.97                     | 52.65                        | 68.20              | -15.55       | PK               |
| Horizontal                       | 10620.19                | 49.90                        | -8.97                     | 40.93                        | 54.00              | -13.07       | AV               |
| Horizontal                       | 15930.19                | 61.70                        | -7.72                     | 53.98                        | 74.00              | -20.02       | PK               |
| Horizontal                       | 15930.19                | 49.35                        | -7.72                     | 41.63                        | 54.00              | -12.37       | AV               |

Note: PK value is lower than the Average value limit, So average didn't record.  
 The 26.5-40G amplitude of spurious emissions that are attenuated by more than 20dB below the permissible value has no need to be reported.  
 Emission level (dBuV/m) = 20 log Emission level (uV/m).  
 Corrected Reading: Antenna Factor + Cable Loss + Read Level - Preamp Factor = Level.  
 Test Mode is MIMO Mode.

|            |                          |
|------------|--------------------------|
| Test Mode: | TX(5.3G) - 802.11ac-HT80 |
|------------|--------------------------|

| Polar<br>(H/V)      | Fre-<br>quency<br>(MHz) | Reading<br>Level<br>(dBuV/m) | Correct<br>Factor<br>(dB) | Measure-<br>ment<br>(dBuV/m) | Limits<br>(dBuV/m) | Over<br>(dB) | Detector<br>Type |
|---------------------|-------------------------|------------------------------|---------------------------|------------------------------|--------------------|--------------|------------------|
| (5290 MHz)-Above 1G |                         |                              |                           |                              |                    |              |                  |
| Vertical            | 4434.10                 | 73.36                        | -20.73                    | 52.63                        | 68.20              | -15.57       | PK               |
| Vertical            | 4434.10                 | 59.86                        | -20.73                    | 39.13                        | 54.00              | -14.87       | AV               |
| Vertical            | 10580.10                | 60.69                        | -9.03                     | 51.66                        | 68.20              | -16.54       | PK               |
| Vertical            | 10580.10                | 49.46                        | -9.03                     | 40.43                        | 54.00              | -13.57       | AV               |
| Vertical            | 15870.18                | 61.62                        | -7.74                     | 53.88                        | 74.00              | -20.12       | PK               |
| Vertical            | 15870.18                | 49.12                        | -7.74                     | 41.38                        | 54.00              | -12.62       | AV               |
| Horizontal          | 4434.02                 | 70.16                        | -20.73                    | 49.43                        | 68.20              | -18.77       | PK               |
| Horizontal          | 4434.02                 | 59.10                        | -20.73                    | 38.37                        | 54.00              | -15.63       | AV               |
| Horizontal          | 10580.19                | 62.64                        | -9.03                     | 53.61                        | 68.20              | -14.59       | PK               |
| Horizontal          | 10580.19                | 49.05                        | -9.03                     | 40.02                        | 54.00              | -13.98       | AV               |
| Horizontal          | 15870.06                | 60.40                        | -7.74                     | 52.66                        | 74.00              | -21.34       | PK               |
| Horizontal          | 15870.06                | 49.72                        | -7.74                     | 41.98                        | 54.00              | -12.02       | AV               |

Note: PK value is lower than the Average value limit, So average didn't record.  
 The 26.5-40G amplitude of spurious emissions that are attenuated by more than 20dB below the permissible value has no need to be reported.  
 Emission level (dBuV/m) = 20 log Emission level (uV/m).  
 Corrected Reading: Antenna Factor + Cable Loss + Read Level - Preamp Factor = Level.  
 Test Mode is MIMO Mode.

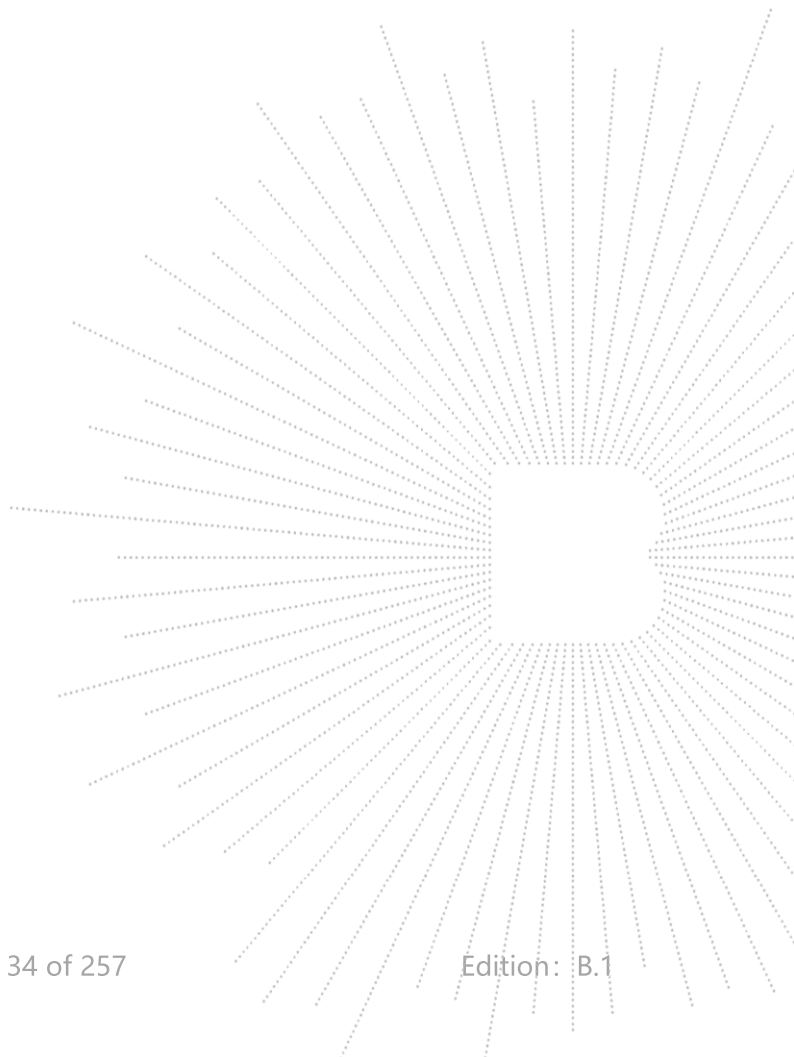

|            |                    |
|------------|--------------------|
| Test Mode: | TX(5.6G) - 802.11a |
|------------|--------------------|

| Polar<br>(H/V)                     | Fre-<br>quency<br>(MHz) | Reading<br>Level<br>(dBuV/m) | Correct<br>Factor<br>(dB) | Measure-<br>ment<br>(dBuV/m) | Limits<br>(dBuV/m) | Over<br>(dB) | Detector<br>Type |
|------------------------------------|-------------------------|------------------------------|---------------------------|------------------------------|--------------------|--------------|------------------|
| Low Channel (5500 MHz)-Above 1G    |                         |                              |                           |                              |                    |              |                  |
| Vertical                           | 4434.08                 | 70.30                        | -20.73                    | 49.57                        | 68.20              | -18.63       | PK               |
| Vertical                           | 4434.08                 | 59.08                        | -20.73                    | 38.34                        | 54.00              | -15.66       | AV               |
| Vertical                           | 11000.16                | 64.44                        | -8.40                     | 56.04                        | 68.20              | -12.16       | PK               |
| Vertical                           | 11000.16                | 49.16                        | -8.40                     | 40.76                        | 54.00              | -13.24       | AV               |
| Vertical                           | 16500.18                | 64.03                        | -6.09                     | 57.94                        | 74.00              | -16.06       | PK               |
| Vertical                           | 16500.18                | 49.11                        | -6.09                     | 43.02                        | 54.00              | -10.98       | AV               |
| Horizontal                         | 4434.18                 | 72.12                        | -20.73                    | 51.39                        | 68.20              | -16.81       | PK               |
| Horizontal                         | 4434.18                 | 59.76                        | -20.73                    | 39.03                        | 54.00              | -14.97       | AV               |
| Horizontal                         | 11000.17                | 61.60                        | -8.40                     | 53.20                        | 68.20              | -15.00       | PK               |
| Horizontal                         | 11000.17                | 49.93                        | -8.40                     | 41.53                        | 54.00              | -12.47       | AV               |
| Horizontal                         | 16500.01                | 60.67                        | -6.09                     | 54.58                        | 74.00              | -19.42       | PK               |
| Horizontal                         | 16500.01                | 49.18                        | -6.09                     | 43.09                        | 54.00              | -10.91       | AV               |
| middle Channel (5580 MHz)-Above 1G |                         |                              |                           |                              |                    |              |                  |
| Vertical                           | 4592.16                 | 70.03                        | -20.42                    | 49.61                        | 74.00              | -24.39       | PK               |
| Vertical                           | 4592.16                 | 59.74                        | -20.42                    | 39.32                        | 54.00              | -14.68       | AV               |
| Vertical                           | 11160.18                | 60.62                        | -8.53                     | 52.09                        | 68.20              | -16.11       | PK               |
| Vertical                           | 11160.18                | 49.15                        | -8.53                     | 40.62                        | 54.00              | -13.38       | AV               |
| Vertical                           | 16740.06                | 63.73                        | -5.31                     | 58.42                        | 74.00              | -15.58       | PK               |
| Vertical                           | 16740.06                | 49.07                        | -5.31                     | 43.76                        | 54.00              | -10.24       | AV               |
| Horizontal                         | 4592.15                 | 72.58                        | -20.42                    | 52.17                        | 74.00              | -21.83       | PK               |
| Horizontal                         | 4592.15                 | 59.64                        | -20.42                    | 39.22                        | 54.00              | -14.78       | AV               |
| Horizontal                         | 11160.04                | 60.31                        | -8.53                     | 51.78                        | 68.20              | -16.42       | PK               |
| Horizontal                         | 11160.04                | 49.74                        | -8.53                     | 41.21                        | 54.00              | -12.79       | AV               |
| Horizontal                         | 16740.07                | 63.97                        | -5.31                     | 58.66                        | 74.00              | -15.34       | PK               |
| Horizontal                         | 16740.07                | 49.65                        | -5.31                     | 44.34                        | 54.00              | -9.66        | AV               |
| High Channel (5700 MHz)-Above 1G   |                         |                              |                           |                              |                    |              |                  |
| Vertical                           | 4739.07                 | 74.13                        | -20.12                    | 54.01                        | 74.00              | -19.99       | PK               |
| Vertical                           | 4739.07                 | 59.60                        | -20.12                    | 39.48                        | 54.00              | -14.52       | AV               |
| Vertical                           | 11400.06                | 64.21                        | -8.72                     | 55.49                        | 68.20              | -12.71       | PK               |
| Vertical                           | 11400.06                | 49.78                        | -8.72                     | 41.06                        | 54.00              | -12.94       | AV               |
| Vertical                           | 17100.06                | 62.77                        | -3.92                     | 58.85                        | 74.00              | -15.15       | PK               |
| Vertical                           | 17100.06                | 49.75                        | -3.92                     | 45.83                        | 54.00              | -8.17        | AV               |
| Horizontal                         | 4739.09                 | 71.41                        | -20.12                    | 51.29                        | 74.00              | -22.71       | PK               |
| Horizontal                         | 4739.09                 | 59.83                        | -20.12                    | 39.71                        | 54.00              | -14.29       | AV               |
| Horizontal                         | 11400.15                | 64.74                        | -8.72                     | 56.02                        | 68.20              | -12.18       | PK               |
| Horizontal                         | 11400.15                | 49.94                        | -8.72                     | 41.22                        | 54.00              | -12.78       | AV               |
| Horizontal                         | 17100.08                | 60.69                        | -3.92                     | 56.77                        | 74.00              | -17.23       | PK               |
| Horizontal                         | 17100.08                | 49.02                        | -3.92                     | 45.10                        | 54.00              | -8.90        | AV               |

Note: PK value is lower than the Average value limit, So average didn't record.  
 The 26.5-40G amplitude of spurious emissions that are attenuated by more than 20dB below the permissible value has no need to be reported.  
 Emission level (dBuV/m) = 20 log Emission level (uV/m).  
 Corrected Reading: Antenna Factor + Cable Loss + Read Level - Preamp Factor = Level.  
 The worst case is Antenna A.

|            |                         |
|------------|-------------------------|
| Test Mode: | TX(5.6G) - 802.11n-HT20 |
|------------|-------------------------|

| Polar<br>(H/V)                     | Fre-<br>quency<br>(MHz) | Reading<br>Level<br>(dBuV/m) | Correct<br>Factor<br>(dB) | Measure-<br>ment<br>(dBuV/m) | Limits<br>(dBuV/m) | Over<br>(dB) | Detector<br>Type |
|------------------------------------|-------------------------|------------------------------|---------------------------|------------------------------|--------------------|--------------|------------------|
| Low Channel (5500 MHz)-Above 1G    |                         |                              |                           |                              |                    |              |                  |
| Vertical                           | 4434.14                 | 70.30                        | -20.73                    | 49.57                        | 68.20              | -18.63       | PK               |
| Vertical                           | 4434.14                 | 59.55                        | -20.73                    | 38.82                        | 54.00              | -15.18       | AV               |
| Vertical                           | 11000.02                | 63.61                        | -8.40                     | 55.21                        | 68.20              | -12.99       | PK               |
| Vertical                           | 11000.02                | 49.87                        | -8.40                     | 41.47                        | 54.00              | -12.53       | AV               |
| Vertical                           | 16500.17                | 63.80                        | -6.09                     | 57.71                        | 74.00              | -16.29       | PK               |
| Vertical                           | 16500.17                | 49.37                        | -6.09                     | 43.28                        | 54.00              | -10.72       | AV               |
| Horizontal                         | 4434.15                 | 72.39                        | -20.73                    | 51.66                        | 68.20              | -16.54       | PK               |
| Horizontal                         | 4434.15                 | 60.00                        | -20.73                    | 39.27                        | 54.00              | -14.73       | AV               |
| Horizontal                         | 11000.20                | 60.32                        | -8.40                     | 51.92                        | 68.20              | -16.28       | PK               |
| Horizontal                         | 11000.20                | 50.00                        | -8.40                     | 41.60                        | 54.00              | -12.40       | AV               |
| Horizontal                         | 16500.10                | 60.42                        | -6.09                     | 54.33                        | 74.00              | -19.67       | PK               |
| Horizontal                         | 16500.10                | 49.75                        | -6.09                     | 43.66                        | 54.00              | -10.34       | AV               |
| middle Channel (5580 MHz)-Above 1G |                         |                              |                           |                              |                    |              |                  |
| Vertical                           | 4592.19                 | 71.46                        | -20.42                    | 51.04                        | 74.00              | -22.96       | PK               |
| Vertical                           | 4592.19                 | 59.93                        | -20.42                    | 39.52                        | 54.00              | -14.48       | AV               |
| Vertical                           | 11160.08                | 63.44                        | -8.53                     | 54.91                        | 68.20              | -13.29       | PK               |
| Vertical                           | 11160.08                | 49.92                        | -8.53                     | 41.39                        | 54.00              | -12.61       | AV               |
| Vertical                           | 16740.11                | 62.88                        | -5.31                     | 57.57                        | 74.00              | -16.43       | PK               |
| Vertical                           | 16740.11                | 49.34                        | -5.31                     | 44.03                        | 54.00              | -9.97        | AV               |
| Horizontal                         | 4592.08                 | 71.79                        | -20.42                    | 51.37                        | 74.00              | -22.63       | PK               |
| Horizontal                         | 4592.08                 | 59.32                        | -20.42                    | 38.90                        | 54.00              | -15.10       | AV               |
| Horizontal                         | 11160.05                | 60.30                        | -8.53                     | 51.77                        | 68.20              | -16.43       | PK               |
| Horizontal                         | 11160.05                | 49.18                        | -8.53                     | 40.65                        | 54.00              | -13.35       | AV               |
| Horizontal                         | 16740.16                | 62.92                        | -5.31                     | 57.61                        | 74.00              | -16.39       | PK               |
| Horizontal                         | 16740.16                | 49.83                        | -5.31                     | 44.52                        | 54.00              | -9.48        | AV               |
| High Channel (5700 MHz)-Above 1G   |                         |                              |                           |                              |                    |              |                  |
| Vertical                           | 4739.06                 | 70.87                        | -20.12                    | 50.74                        | 74.00              | -23.26       | PK               |
| Vertical                           | 4739.06                 | 59.84                        | -20.12                    | 39.72                        | 54.00              | -14.28       | AV               |
| Vertical                           | 11400.00                | 62.18                        | -8.72                     | 53.46                        | 68.20              | -14.74       | PK               |
| Vertical                           | 11400.00                | 49.22                        | -8.72                     | 40.50                        | 54.00              | -13.50       | AV               |
| Vertical                           | 17100.09                | 64.82                        | -3.92                     | 60.90                        | 74.00              | -13.10       | PK               |
| Vertical                           | 17100.09                | 49.74                        | -3.92                     | 45.82                        | 54.00              | -8.18        | AV               |
| Horizontal                         | 4739.12                 | 73.16                        | -20.12                    | 53.04                        | 74.00              | -20.96       | PK               |
| Horizontal                         | 4739.12                 | 59.92                        | -20.12                    | 39.80                        | 54.00              | -14.20       | AV               |
| Horizontal                         | 11400.15                | 60.66                        | -8.72                     | 51.94                        | 68.20              | -16.26       | PK               |
| Horizontal                         | 11400.15                | 49.48                        | -8.72                     | 40.76                        | 54.00              | -13.24       | AV               |
| Horizontal                         | 17100.17                | 60.83                        | -3.92                     | 56.91                        | 74.00              | -17.09       | PK               |
| Horizontal                         | 17100.17                | 49.60                        | -3.92                     | 45.68                        | 54.00              | -8.32        | AV               |

Note: PK value is lower than the Average value limit, So average didn't record.  
 The 26.5-40G amplitude of spurious emissions that are attenuated by more than 20dB below the permissible value has no need to be reported.  
 Emission level (dBuV/m) = 20 log Emission level (uV/m).  
 Corrected Reading: Antenna Factor + Cable Loss + Read Level - Preamp Factor = Level.  
 Test Mode is MIMO Mode.

|            |                         |
|------------|-------------------------|
| Test Mode: | TX(5.6G) - 802.11n-HT40 |
|------------|-------------------------|

| Polar<br>(H/V)                     | Fre-<br>quency<br>(MHz) | Reading<br>Level<br>(dBuV/m) | Correct<br>Factor<br>(dB) | Measure-<br>ment<br>(dBuV/m) | Limits<br>(dBuV/m) | Over<br>(dB) | Detector<br>Type |
|------------------------------------|-------------------------|------------------------------|---------------------------|------------------------------|--------------------|--------------|------------------|
| Low Channel (5510 MHz)-Above 1G    |                         |                              |                           |                              |                    |              |                  |
| Vertical                           | 4434.08                 | 61.96                        | -20.73                    | 41.23                        | 68.20              | -26.97       | PK               |
| Vertical                           | 4434.08                 | 43.80                        | -20.73                    | 23.07                        | 54.00              | -30.93       | AV               |
| Vertical                           | 11020.19                | 62.82                        | -8.42                     | 54.40                        | 68.20              | -13.80       | PK               |
| Vertical                           | 11020.19                | 43.32                        | -8.42                     | 34.90                        | 54.00              | -19.10       | AV               |
| Vertical                           | 16530.07                | 62.00                        | -5.99                     | 56.01                        | 74.00              | -17.99       | PK               |
| Vertical                           | 16530.07                | 43.93                        | -5.99                     | 37.94                        | 54.00              | -16.06       | AV               |
| Horizontal                         | 4434.19                 | 64.11                        | -20.73                    | 43.38                        | 74.00              | -30.62       | PK               |
| Horizontal                         | 4434.19                 | 43.23                        | -20.73                    | 22.50                        | 54.00              | -31.50       | AV               |
| Horizontal                         | 11020.18                | 52.01                        | -8.42                     | 43.59                        | 68.20              | -24.61       | PK               |
| Horizontal                         | 11020.18                | 42.00                        | -8.42                     | 33.58                        | 54.00              | -20.42       | AV               |
| Horizontal                         | 16530.01                | 52.64                        | -5.99                     | 46.65                        | 74.00              | -27.35       | PK               |
| Horizontal                         | 16530.01                | 43.96                        | -5.99                     | 37.97                        | 54.00              | -16.03       | AV               |
| middle Channel (5550 MHz)-Above 1G |                         |                              |                           |                              |                    |              |                  |
| Vertical                           | 4592.09                 | 63.35                        | -20.42                    | 42.93                        | 74.00              | -31.07       | PK               |
| Vertical                           | 4592.09                 | 43.04                        | -20.42                    | 22.63                        | 54.00              | -31.37       | AV               |
| Vertical                           | 11100.01                | 62.44                        | -8.40                     | 54.04                        | 68.20              | -14.16       | PK               |
| Vertical                           | 11100.01                | 43.73                        | -8.40                     | 35.33                        | 54.00              | -18.67       | AV               |
| Vertical                           | 16650.10                | 64.05                        | -5.60                     | 58.45                        | 74.00              | -15.55       | PK               |
| Vertical                           | 16650.10                | 43.41                        | -5.60                     | 37.81                        | 54.00              | -16.19       | AV               |
| Horizontal                         | 4592.03                 | 63.98                        | -20.42                    | 43.56                        | 74.00              | -30.44       | PK               |
| Horizontal                         | 4592.03                 | 43.31                        | -20.42                    | 22.89                        | 54.00              | -31.11       | AV               |
| Horizontal                         | 11100.04                | 51.78                        | -8.40                     | 43.38                        | 68.20              | -24.82       | PK               |
| Horizontal                         | 11100.04                | 40.63                        | -8.40                     | 32.23                        | 54.00              | -21.77       | AV               |
| Horizontal                         | 16650.09                | 50.56                        | -5.60                     | 44.96                        | 74.00              | -29.04       | PK               |
| Horizontal                         | 16650.09                | 44.89                        | -5.60                     | 39.29                        | 54.00              | -14.71       | AV               |
| High Channel (5670 MHz)-Above 1G   |                         |                              |                           |                              |                    |              |                  |
| Vertical                           | 4739.04                 | 63.09                        | -20.12                    | 42.97                        | 68.20              | -25.23       | PK               |
| Vertical                           | 4739.04                 | 43.37                        | -20.12                    | 23.25                        | 54.00              | -30.75       | AV               |
| Vertical                           | 11340.03                | 63.83                        | -8.67                     | 55.16                        | 68.20              | -13.04       | PK               |
| Vertical                           | 11340.03                | 43.62                        | -8.67                     | 34.95                        | 54.00              | -19.05       | AV               |
| Vertical                           | 17010.01                | 62.65                        | -4.41                     | 58.24                        | 74.00              | -15.76       | PK               |
| Vertical                           | 17010.01                | 43.64                        | -4.41                     | 39.23                        | 54.00              | -14.77       | AV               |
| Horizontal                         | 4739.03                 | 62.58                        | -20.12                    | 42.46                        | 68.20              | -25.74       | PK               |
| Horizontal                         | 4739.03                 | 43.13                        | -20.12                    | 23.00                        | 54.00              | -31.00       | AV               |
| Horizontal                         | 11340.10                | 52.10                        | -8.67                     | 43.43                        | 68.20              | -24.77       | PK               |
| Horizontal                         | 11340.10                | 40.05                        | -8.67                     | 31.38                        | 54.00              | -22.62       | AV               |
| Horizontal                         | 17010.20                | 51.27                        | -4.41                     | 46.86                        | 74.00              | -27.14       | PK               |
| Horizontal                         | 17010.20                | 42.02                        | -4.41                     | 37.61                        | 54.00              | -16.39       | AV               |

Note: PK value is lower than the Average value limit, So average didn't record.  
 The 26.5-40G amplitude of spurious emissions that are attenuated by more than 20dB below the permissible value has no need to be reported.  
 Emission level (dBuV/m) = 20 log Emission level (uV/m).  
 Corrected Reading: Antenna Factor + Cable Loss + Read Level - Preamp Factor = Level.  
 Test Mode is MIMO Mode.

|            |                          |
|------------|--------------------------|
| Test Mode: | TX(5.6G) - 802.11ac-HT20 |
|------------|--------------------------|

| Polar<br>(H/V)                     | Fre-<br>quency<br>(MHz) | Reading<br>Level<br>(dBuV/m) | Correct<br>Factor<br>(dB) | Measure-<br>ment<br>(dBuV/m) | Limits<br>(dBuV/m) | Over<br>(dB) | Detector<br>Type |
|------------------------------------|-------------------------|------------------------------|---------------------------|------------------------------|--------------------|--------------|------------------|
| Low Channel (5500 MHz)-Above 1G    |                         |                              |                           |                              |                    |              |                  |
| Vertical                           | 4434.07                 | 72.19                        | -20.73                    | 51.45                        | 68.20              | -16.75       | PK               |
| Vertical                           | 4434.07                 | 59.47                        | -20.73                    | 38.74                        | 54.00              | -15.26       | AV               |
| Vertical                           | 11000.15                | 60.41                        | -8.40                     | 52.01                        | 68.20              | -16.19       | PK               |
| Vertical                           | 11000.15                | 49.21                        | -8.40                     | 40.81                        | 54.00              | -13.19       | AV               |
| Vertical                           | 16500.19                | 61.05                        | -6.09                     | 54.96                        | 74.00              | -19.04       | PK               |
| Vertical                           | 16500.19                | 49.08                        | -6.09                     | 42.99                        | 54.00              | -11.01       | AV               |
| Horizontal                         | 4434.16                 | 73.15                        | -20.73                    | 52.42                        | 68.20              | -15.78       | PK               |
| Horizontal                         | 4434.16                 | 59.16                        | -20.73                    | 38.43                        | 54.00              | -15.57       | AV               |
| Horizontal                         | 11000.06                | 61.35                        | -8.40                     | 52.95                        | 68.20              | -15.25       | PK               |
| Horizontal                         | 11000.06                | 49.57                        | -8.40                     | 41.17                        | 54.00              | -12.83       | AV               |
| Horizontal                         | 16500.04                | 62.64                        | -6.09                     | 56.55                        | 74.00              | -17.45       | PK               |
| Horizontal                         | 16500.04                | 49.65                        | -6.09                     | 43.56                        | 54.00              | -10.44       | AV               |
| middle Channel (5580 MHz)-Above 1G |                         |                              |                           |                              |                    |              |                  |
| Vertical                           | 4592.19                 | 70.45                        | -20.42                    | 50.03                        | 74.00              | -23.97       | PK               |
| Vertical                           | 4592.19                 | 59.26                        | -20.42                    | 38.85                        | 54.00              | -15.15       | AV               |
| Vertical                           | 11160.08                | 62.97                        | -8.53                     | 54.44                        | 68.20              | -13.76       | PK               |
| Vertical                           | 11160.08                | 49.25                        | -8.53                     | 40.72                        | 54.00              | -13.28       | AV               |
| Vertical                           | 16740.06                | 62.31                        | -5.31                     | 57.00                        | 74.00              | -17.00       | PK               |
| Vertical                           | 16740.06                | 49.14                        | -5.31                     | 43.83                        | 54.00              | -10.17       | AV               |
| Horizontal                         | 4592.06                 | 70.46                        | -20.42                    | 50.05                        | 74.00              | -23.95       | PK               |
| Horizontal                         | 4592.06                 | 59.03                        | -20.42                    | 38.61                        | 54.00              | -15.39       | AV               |
| Horizontal                         | 11160.00                | 63.72                        | -8.53                     | 55.19                        | 68.20              | -13.01       | PK               |
| Horizontal                         | 11160.00                | 49.95                        | -8.53                     | 41.42                        | 54.00              | -12.58       | AV               |
| Horizontal                         | 16740.06                | 60.95                        | -5.31                     | 55.64                        | 74.00              | -18.36       | PK               |
| Horizontal                         | 16740.06                | 49.77                        | -5.31                     | 44.46                        | 54.00              | -9.54        | AV               |
| High Channel (5700 MHz)-Above 1G   |                         |                              |                           |                              |                    |              |                  |
| Vertical                           | 4739.13                 | 70.57                        | -20.12                    | 50.45                        | 74.00              | -23.55       | PK               |
| Vertical                           | 4739.13                 | 59.79                        | -20.12                    | 39.67                        | 54.00              | -14.33       | AV               |
| Vertical                           | 11400.20                | 64.80                        | -8.72                     | 56.08                        | 68.20              | -12.12       | PK               |
| Vertical                           | 11400.20                | 49.51                        | -8.72                     | 40.79                        | 54.00              | -13.21       | AV               |
| Vertical                           | 17100.03                | 64.13                        | -3.92                     | 60.21                        | 74.00              | -13.79       | PK               |
| Vertical                           | 17100.03                | 49.70                        | -3.92                     | 45.78                        | 54.00              | -8.22        | AV               |
| Horizontal                         | 4739.05                 | 71.52                        | -20.12                    | 51.39                        | 74.00              | -22.61       | PK               |
| Horizontal                         | 4739.05                 | 59.07                        | -20.12                    | 38.95                        | 54.00              | -15.05       | AV               |
| Horizontal                         | 11400.00                | 64.77                        | -8.72                     | 56.05                        | 68.20              | -12.15       | PK               |
| Horizontal                         | 11400.00                | 49.73                        | -8.72                     | 41.01                        | 54.00              | -12.99       | AV               |
| Horizontal                         | 17100.13                | 61.85                        | -3.92                     | 57.93                        | 74.00              | -16.07       | PK               |
| Horizontal                         | 17100.13                | 49.05                        | -3.92                     | 45.13                        | 54.00              | -8.87        | AV               |

Note: PK value is lower than the Average value limit, So average didn't record.

The 26.5-40G amplitude of spurious emissions that are attenuated by more than 20dB below the permissible value has no need to be reported.

Emission level (dBuV/m) = 20 log Emission level (uV/m).

Corrected Reading: Antenna Factor + Cable Loss + Read Level - Preamp Factor = Level.

Test Mode is MIMO Mode.

|            |                          |
|------------|--------------------------|
| Test Mode: | TX(5.6G) - 802.11ac-HT40 |
|------------|--------------------------|

| Polar                              | Fre-<br>quency | Reading<br>Level | Correct<br>Factor | Measure-<br>ment | Limits   | Over   | Detector<br>Type |
|------------------------------------|----------------|------------------|-------------------|------------------|----------|--------|------------------|
| (H/V)                              | (MHz)          | (dBuV/m)         | (dB)              | (dBuV/m)         | (dBuV/m) | (dB)   |                  |
| Low Channel (5510 MHz)-Above 1G    |                |                  |                   |                  |          |        |                  |
| Vertical                           | 4434.16        | 63.38            | -20.73            | 42.65            | 68.20    | -25.55 | PK               |
| Vertical                           | 4434.16        | 44.00            | -20.73            | 23.27            | 54.00    | -30.73 | AV               |
| Vertical                           | 11020.07       | 62.99            | -8.42             | 54.57            | 68.20    | -13.63 | PK               |
| Vertical                           | 11020.07       | 43.15            | -8.42             | 34.73            | 54.00    | -19.27 | AV               |
| Vertical                           | 16530.01       | 64.62            | -5.99             | 58.63            | 74.00    | -15.37 | PK               |
| Vertical                           | 16530.01       | 43.29            | -5.99             | 37.30            | 54.00    | -16.70 | AV               |
| Horizontal                         | 4434.09        | 63.61            | -20.73            | 42.88            | 74.00    | -31.12 | PK               |
| Horizontal                         | 4434.09        | 43.08            | -20.73            | 22.34            | 54.00    | -31.66 | AV               |
| Horizontal                         | 11020.05       | 53.98            | -8.42             | 45.56            | 68.20    | -22.64 | PK               |
| Horizontal                         | 11020.05       | 42.97            | -8.42             | 34.55            | 54.00    | -19.45 | AV               |
| Horizontal                         | 16530.20       | 52.70            | -5.99             | 46.71            | 74.00    | -27.29 | PK               |
| Horizontal                         | 16530.20       | 43.27            | -5.99             | 37.28            | 54.00    | -16.72 | AV               |
| middle Channel (5550 MHz)-Above 1G |                |                  |                   |                  |          |        |                  |
| Vertical                           | 4592.15        | 61.27            | -20.42            | 40.86            | 74.00    | -33.14 | PK               |
| Vertical                           | 4592.15        | 43.79            | -20.42            | 23.38            | 54.00    | -30.62 | AV               |
| Vertical                           | 11100.16       | 60.95            | -8.40             | 52.55            | 68.20    | -15.65 | PK               |
| Vertical                           | 11100.16       | 43.53            | -8.40             | 35.13            | 54.00    | -18.87 | AV               |
| Vertical                           | 16650.19       | 61.52            | -5.60             | 55.92            | 74.00    | -18.08 | PK               |
| Vertical                           | 16650.19       | 43.57            | -5.60             | 37.97            | 54.00    | -16.03 | AV               |
| Horizontal                         | 4592.07        | 63.70            | -20.42            | 43.29            | 74.00    | -30.71 | PK               |
| Horizontal                         | 4592.07        | 43.86            | -20.42            | 23.45            | 54.00    | -30.55 | AV               |
| Horizontal                         | 11100.04       | 50.42            | -8.40             | 42.02            | 68.20    | -26.18 | PK               |
| Horizontal                         | 11100.04       | 44.99            | -8.40             | 36.59            | 54.00    | -17.41 | AV               |
| Horizontal                         | 16650.04       | 54.28            | -5.60             | 48.68            | 74.00    | -25.32 | PK               |
| Horizontal                         | 16650.04       | 44.41            | -5.60             | 38.81            | 54.00    | -15.19 | AV               |
| High Channel (5670 MHz)-Above 1G   |                |                  |                   |                  |          |        |                  |
| Vertical                           | 4739.18        | 62.82            | -20.12            | 42.70            | 68.20    | -25.50 | PK               |
| Vertical                           | 4739.18        | 43.32            | -20.12            | 23.20            | 54.00    | -30.80 | AV               |
| Vertical                           | 11340.01       | 62.18            | -8.67             | 53.51            | 68.20    | -14.69 | PK               |
| Vertical                           | 11340.01       | 43.61            | -8.67             | 34.94            | 54.00    | -19.06 | AV               |
| Vertical                           | 17010.09       | 64.96            | -4.41             | 60.55            | 74.00    | -13.45 | PK               |
| Vertical                           | 17010.09       | 43.03            | -4.41             | 38.62            | 54.00    | -15.38 | AV               |
| Horizontal                         | 4739.12        | 64.93            | -20.12            | 44.81            | 68.20    | -23.39 | PK               |
| Horizontal                         | 4739.12        | 43.49            | -20.12            | 23.36            | 54.00    | -30.64 | AV               |
| Horizontal                         | 11340.13       | 52.17            | -8.67             | 43.50            | 68.20    | -24.70 | PK               |
| Horizontal                         | 11340.13       | 44.84            | -8.67             | 36.17            | 54.00    | -17.83 | AV               |
| Horizontal                         | 17010.16       | 52.34            | -4.41             | 47.93            | 74.00    | -26.07 | PK               |
| Horizontal                         | 17010.16       | 42.39            | -4.41             | 37.98            | 54.00    | -16.02 | AV               |

Note: PK value is lower than the Average value limit, So average didn't record.

The 26.5-40G amplitude of spurious emissions that are attenuated by more than 20dB below the permissible value has no need to be reported.

Emission level (dBuV/m) = 20 log Emission level (uV/m).

Corrected Reading: Antenna Factor + Cable Loss + Read Level - Preamp Factor = Level.

Test Mode is MIMO Mode.

|            |                          |
|------------|--------------------------|
| Test Mode: | TX(5.6G) - 802.11ac-HT80 |
|------------|--------------------------|

| Polar<br>(H/V)      | Fre-<br>quency<br>(MHz) | Reading<br>Level<br>(dBuV/m) | Correct<br>Factor<br>(dB) | Measure-<br>ment<br>(dBuV/m) | Limits<br>(dBuV/m) | Over<br>(dB) | Detector<br>Type |
|---------------------|-------------------------|------------------------------|---------------------------|------------------------------|--------------------|--------------|------------------|
| (5530 MHz)-Above 1G |                         |                              |                           |                              |                    |              |                  |
| Vertical            | 4434.05                 | 64.82                        | -20.73                    | 44.09                        | 68.20              | -24.11       | PK               |
| Vertical            | 4434.05                 | 43.23                        | -20.73                    | 22.49                        | 54.00              | -31.51       | AV               |
| Vertical            | 11060.07                | 61.43                        | -8.45                     | 52.98                        | 68.20              | -15.22       | PK               |
| Vertical            | 11060.07                | 43.17                        | -8.45                     | 34.72                        | 54.00              | -19.28       | AV               |
| Vertical            | 16590.19                | 64.87                        | -5.79                     | 59.08                        | 74.00              | -14.92       | PK               |
| Vertical            | 16590.19                | 43.90                        | -5.79                     | 38.11                        | 54.00              | -15.89       | AV               |
| Horizontal          | 4434.05                 | 61.32                        | -20.73                    | 40.59                        | 68.20              | -27.61       | PK               |
| Horizontal          | 4434.05                 | 43.92                        | -20.73                    | 23.19                        | 54.00              | -30.81       | AV               |
| Horizontal          | 11060.01                | 52.18                        | -8.45                     | 43.73                        | 68.20              | -24.47       | PK               |
| Horizontal          | 11060.01                | 44.46                        | -8.45                     | 36.01                        | 54.00              | -17.99       | AV               |
| Horizontal          | 16590.03                | 50.57                        | -5.79                     | 44.78                        | 74.00              | -29.22       | PK               |
| Horizontal          | 16590.03                | 44.71                        | -5.79                     | 38.92                        | 54.00              | -15.08       | AV               |

Note: PK value is lower than the Average value limit, So average didn't record.

The 26.5-40G amplitude of spurious emissions that are attenuated by more than 20dB below the permissible value has no need to be reported.

Emission level (dBuV/m) = 20 log Emission level (uV/m).

Corrected Reading: Antenna Factor + Cable Loss + Read Level - Preamp Factor = Level.

Test Mode is MIMO Mode.

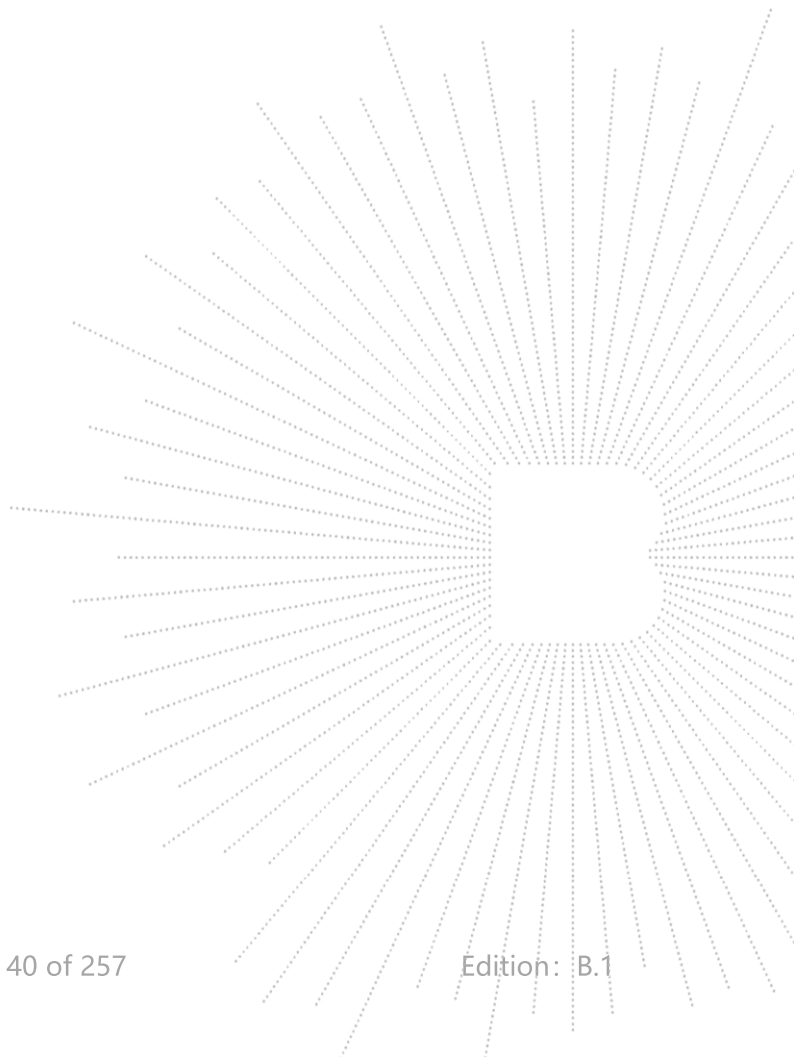



|            |                    |
|------------|--------------------|
| Test Mode: | TX(5.8G) - 802.11a |
|------------|--------------------|

| Polar<br>(H/V)                     | Fre-<br>quency<br>(MHz) | Reading<br>Level<br>(dBuV/m) | Correct<br>Factor<br>(dB) | Measure-<br>ment<br>(dBuV/m) | Limits<br>(dBuV/m) | Over<br>(dB) | Detector<br>Type |
|------------------------------------|-------------------------|------------------------------|---------------------------|------------------------------|--------------------|--------------|------------------|
| Low Channel (5745 MHz)-Above 1G    |                         |                              |                           |                              |                    |              |                  |
| Vertical                           | 4679.07                 | 71.40                        | -20.24                    | 51.16                        | 74.00              | -22.84       | PK               |
| Vertical                           | 4679.07                 | 59.79                        | -20.24                    | 39.55                        | 54.00              | -14.45       | AV               |
| Vertical                           | 11490.08                | 62.32                        | -8.79                     | 53.53                        | 68.20              | -14.67       | PK               |
| Vertical                           | 11490.08                | 49.96                        | -8.79                     | 41.17                        | 54.00              | -12.83       | AV               |
| Vertical                           | 17235.00                | 58.23                        | -3.18                     | 55.05                        | 68.20              | -13.15       | PK               |
| Vertical                           | 17235.00                | 44.35                        | -3.18                     | 41.17                        | 54.00              | -12.83       | AV               |
| Horizontal                         | 4679.11                 | 71.49                        | -20.73                    | 50.76                        | 74.00              | -23.24       | PK               |
| Horizontal                         | 4679.11                 | 59.38                        | -20.73                    | 38.65                        | 54.00              | -15.35       | AV               |
| Horizontal                         | 11490.19                | 62.48                        | -8.79                     | 53.69                        | 68.20              | -14.51       | PK               |
| Horizontal                         | 11490.19                | 49.73                        | -8.79                     | 40.94                        | 54.00              | -13.06       | AV               |
| Horizontal                         | 17235.09                | 57.96                        | -3.18                     | 54.78                        | 68.20              | -13.42       | PK               |
| Horizontal                         | 17235.09                | 44.57                        | -3.18                     | 41.39                        | 54.00              | -12.61       | AV               |
| middle Channel (5785 MHz)-Above 1G |                         |                              |                           |                              |                    |              |                  |
| Vertical                           | 4592.01                 | 72.21                        | -20.42                    | 51.79                        | 74.00              | -22.21       | PK               |
| Vertical                           | 4592.01                 | 59.05                        | -20.42                    | 38.64                        | 54.00              | -15.36       | AV               |
| Vertical                           | 11570.10                | 63.22                        | -8.86                     | 54.36                        | 68.20              | -13.84       | PK               |
| Vertical                           | 11570.10                | 49.94                        | -8.86                     | 41.08                        | 54.00              | -12.92       | AV               |
| Vertical                           | 17355.13                | 56.15                        | -2.52                     | 53.63                        | 68.20              | -14.57       | PK               |
| Vertical                           | 17355.13                | 44.63                        | -2.52                     | 42.11                        | 54.00              | -11.89       | AV               |
| Horizontal                         | 4592.03                 | 70.42                        | -20.42                    | 50.01                        | 74.00              | -23.99       | PK               |
| Horizontal                         | 4592.03                 | 59.49                        | -20.42                    | 39.08                        | 54.00              | -14.92       | AV               |
| Horizontal                         | 11570.04                | 61.28                        | -8.86                     | 52.42                        | 68.20              | -15.78       | PK               |
| Horizontal                         | 11570.04                | 49.28                        | -8.86                     | 40.42                        | 54.00              | -13.58       | AV               |
| Horizontal                         | 17355.06                | 57.44                        | -2.52                     | 54.92                        | 68.20              | -13.28       | PK               |
| Horizontal                         | 17355.06                | 44.38                        | -2.52                     | 41.86                        | 54.00              | -12.14       | AV               |
| High Channel (5825 MHz)-Above 1G   |                         |                              |                           |                              |                    |              |                  |
| Vertical                           | 6039.07                 | 71.26                        | -18.93                    | 52.32                        | 68.20              | -15.88       | PK               |
| Vertical                           | 6039.07                 | 59.35                        | -18.93                    | 40.42                        | 54.00              | -13.58       | AV               |
| Vertical                           | 11650.04                | 64.13                        | -8.92                     | 55.21                        | 74.00              | -18.79       | PK               |
| Vertical                           | 11650.04                | 49.42                        | -8.92                     | 40.50                        | 54.00              | -13.50       | AV               |
| Vertical                           | 17475.16                | 59.17                        | -1.86                     | 57.31                        | 68.20              | -10.89       | PK               |
| Vertical                           | 17475.16                | 44.25                        | -1.86                     | 42.39                        | 54.00              | -11.61       | AV               |
| Horizontal                         | 6039.09                 | 72.92                        | -18.93                    | 53.99                        | 68.20              | -14.21       | PK               |
| Horizontal                         | 6039.09                 | 59.78                        | -18.93                    | 40.84                        | 54.00              | -13.16       | AV               |
| Horizontal                         | 11650.16                | 63.34                        | -8.92                     | 54.42                        | 74.00              | -19.58       | PK               |
| Horizontal                         | 11650.16                | 49.48                        | -8.92                     | 40.56                        | 54.00              | -13.44       | AV               |
| Horizontal                         | 17475.13                | 55.07                        | -1.86                     | 53.21                        | 68.20              | -14.99       | PK               |
| Horizontal                         | 17475.13                | 44.79                        | -1.86                     | 42.93                        | 54.00              | -11.07       | AV               |

Note: PK value is lower than the Average value limit, So average didn't record.  
 The 26.5-40G amplitude of spurious emissions that are attenuated by more than 20dB below the permissible value has no need to be reported.  
 Emission level (dBuV/m) = 20 log Emission level (uV/m).  
 Corrected Reading: Antenna Factor + Cable Loss + Read Level - Preamp Factor = Level.  
 The worst case is Antenna A.

|            |                         |
|------------|-------------------------|
| Test Mode: | TX(5.8G) - 802.11n-HT20 |
|------------|-------------------------|

| Polar<br>(H/V)                     | Fre-<br>quency<br>(MHz) | Reading<br>Level<br>(dBuV/m) | Correct<br>Factor<br>(dB) | Measure-<br>ment<br>(dBuV/m) | Limits<br>(dBuV/m) | Over<br>(dB) | Detector<br>Type |
|------------------------------------|-------------------------|------------------------------|---------------------------|------------------------------|--------------------|--------------|------------------|
| Low Channel (5745 MHz)-Above 1G    |                         |                              |                           |                              |                    |              |                  |
| Vertical                           | 4679.16                 | 72.49                        | -20.24                    | 52.25                        | 74.00              | -21.75       | PK               |
| Vertical                           | 4679.16                 | 59.68                        | -20.24                    | 39.44                        | 54.00              | -14.56       | AV               |
| Vertical                           | 11490.08                | 62.50                        | -8.79                     | 53.71                        | 68.20              | -14.49       | PK               |
| Vertical                           | 11490.08                | 49.35                        | -8.79                     | 40.56                        | 54.00              | -13.44       | AV               |
| Vertical                           | 17235.05                | 57.28                        | -3.18                     | 54.10                        | 68.20              | -14.10       | PK               |
| Vertical                           | 17235.05                | 44.05                        | -3.18                     | 40.87                        | 54.00              | -13.13       | AV               |
| Horizontal                         | 4679.16                 | 70.44                        | -20.24                    | 50.20                        | 74.00              | -23.80       | PK               |
| Horizontal                         | 4679.16                 | 59.74                        | -20.24                    | 39.50                        | 54.00              | -14.50       | AV               |
| Horizontal                         | 11490.01                | 61.53                        | -8.79                     | 52.74                        | 68.20              | -15.46       | PK               |
| Horizontal                         | 11490.01                | 49.82                        | -8.79                     | 41.03                        | 54.00              | -12.97       | AV               |
| Horizontal                         | 17235.16                | 59.62                        | -3.18                     | 56.44                        | 68.20              | -11.76       | PK               |
| Horizontal                         | 17235.16                | 44.75                        | -3.18                     | 41.57                        | 54.00              | -12.43       | AV               |
| middle Channel (5785 MHz)-Above 1G |                         |                              |                           |                              |                    |              |                  |
| Vertical                           | 4592.15                 | 73.14                        | -20.42                    | 52.72                        | 74.00              | -21.28       | PK               |
| Vertical                           | 4592.15                 | 59.74                        | -20.42                    | 39.32                        | 54.00              | -14.68       | AV               |
| Vertical                           | 11570.09                | 61.57                        | -8.86                     | 52.71                        | 68.20              | -15.49       | PK               |
| Vertical                           | 11570.09                | 49.09                        | -8.86                     | 40.23                        | 54.00              | -13.77       | AV               |
| Vertical                           | 17355.03                | 57.77                        | -2.52                     | 55.25                        | 68.20              | -12.95       | PK               |
| Vertical                           | 17355.03                | 44.19                        | -2.52                     | 41.67                        | 54.00              | -12.33       | AV               |
| Horizontal                         | 4592.20                 | 73.86                        | -20.42                    | 53.44                        | 74.00              | -20.56       | PK               |
| Horizontal                         | 4592.20                 | 59.10                        | -20.42                    | 38.68                        | 54.00              | -15.32       | AV               |
| Horizontal                         | 11570.19                | 64.62                        | -8.86                     | 55.76                        | 68.20              | -12.44       | PK               |
| Horizontal                         | 11570.19                | 49.85                        | -8.86                     | 40.99                        | 54.00              | -13.01       | AV               |
| Horizontal                         | 17355.01                | 55.41                        | -2.52                     | 52.89                        | 68.20              | -15.31       | PK               |
| Horizontal                         | 17355.01                | 44.08                        | -2.52                     | 41.56                        | 54.00              | -12.44       | AV               |
| High Channel (5825 MHz)-Above 1G   |                         |                              |                           |                              |                    |              |                  |
| Vertical                           | 6039.20                 | 71.30                        | -18.93                    | 52.37                        | 68.20              | -15.83       | PK               |
| Vertical                           | 6039.20                 | 59.60                        | -18.93                    | 40.67                        | 54.00              | -13.33       | AV               |
| Vertical                           | 11650.15                | 61.80                        | -8.92                     | 52.88                        | 74.00              | -21.12       | PK               |
| Vertical                           | 11650.15                | 49.16                        | -8.92                     | 40.24                        | 54.00              | -13.76       | AV               |
| Vertical                           | 17475.10                | 58.53                        | -1.86                     | 56.67                        | 68.20              | -11.53       | PK               |
| Vertical                           | 17475.10                | 44.56                        | -1.86                     | 42.70                        | 54.00              | -11.30       | AV               |
| Horizontal                         | 6039.16                 | 71.66                        | -18.93                    | 52.73                        | 68.20              | -15.47       | PK               |
| Horizontal                         | 6039.16                 | 59.85                        | -18.93                    | 40.92                        | 54.00              | -13.08       | AV               |
| Horizontal                         | 11650.05                | 62.94                        | -8.92                     | 54.02                        | 74.00              | -19.98       | PK               |
| Horizontal                         | 11650.05                | 49.64                        | -8.92                     | 40.72                        | 54.00              | -13.28       | AV               |
| Horizontal                         | 17475.04                | 57.95                        | -1.86                     | 56.09                        | 68.20              | -12.11       | PK               |
| Horizontal                         | 17475.04                | 44.93                        | -1.86                     | 43.07                        | 54.00              | -10.93       | AV               |

Note: PK value is lower than the Average value limit, So average didn't record.  
 The 26.5-40G amplitude of spurious emissions that are attenuated by more than 20dB below the permissible value has no need to be reported.  
 Emission level (dBuV/m) = 20 log Emission level (uV/m).  
 Corrected Reading: Antenna Factor + Cable Loss + Read Level - Preamp Factor = Level.  
 Test Mode is MIMO Mode.

|            |                         |
|------------|-------------------------|
| Test Mode: | TX(5.8G) - 802.11n-HT40 |
|------------|-------------------------|

| Polar                            | Fre-<br>quency | Reading<br>Level | Correct<br>Factor | Measure-<br>ment | Limits   | Over   | Detector<br>Type |
|----------------------------------|----------------|------------------|-------------------|------------------|----------|--------|------------------|
| (H/V)                            | (MHz)          | (dBuV/m)         | (dB)              | (dBuV/m)         | (dBuV/m) | (dB)   |                  |
| Low Channel (5755 MHz)-Above 1G  |                |                  |                   |                  |          |        |                  |
| Vertical                         | 4679.02        | 73.47            | -20.24            | 53.23            | 74.00    | -20.77 | PK               |
| Vertical                         | 4679.02        | 59.41            | -20.24            | 39.17            | 54.00    | -14.83 | AV               |
| Vertical                         | 11510.14       | 60.73            | -8.81             | 51.92            | 74.00    | -22.08 | PK               |
| Vertical                         | 11510.14       | 49.43            | -8.81             | 40.62            | 54.00    | -13.38 | AV               |
| Vertical                         | 17265.15       | 57.73            | -3.01             | 54.72            | 68.20    | -13.48 | PK               |
| Vertical                         | 17265.15       | 44.46            | -3.01             | 41.45            | 54.00    | -12.55 | AV               |
| Horizontal                       | 4679.06        | 73.35            | -20.24            | 53.11            | 74.00    | -20.89 | PK               |
| Horizontal                       | 4679.06        | 59.15            | -20.24            | 38.91            | 54.00    | -15.09 | AV               |
| Horizontal                       | 11510.04       | 60.87            | -8.81             | 52.06            | 74.00    | -21.94 | PK               |
| Horizontal                       | 11510.04       | 49.71            | -8.81             | 40.90            | 54.00    | -13.10 | AV               |
| Horizontal                       | 17265.18       | 56.60            | -3.01             | 53.59            | 68.20    | -14.61 | PK               |
| Horizontal                       | 17265.18       | 44.60            | -3.01             | 41.59            | 54.00    | -12.41 | AV               |
| High Channel (5795 MHz)-Above 1G |                |                  |                   |                  |          |        |                  |
| Vertical                         | 6039.10        | 72.80            | -18.93            | 53.87            | 68.20    | -14.33 | PK               |
| Vertical                         | 6039.10        | 59.45            | -18.93            | 40.52            | 54.00    | -13.48 | AV               |
| Vertical                         | 11590.09       | 64.18            | -8.87             | 55.31            | 74.00    | -18.69 | PK               |
| Vertical                         | 11590.09       | 49.50            | -8.87             | 40.63            | 54.00    | -13.37 | AV               |
| Vertical                         | 17385.14       | 59.64            | -2.35             | 57.29            | 68.20    | -10.91 | PK               |
| Vertical                         | 17385.14       | 44.46            | -2.35             | 42.11            | 54.00    | -11.89 | AV               |
| Horizontal                       | 6039.14        | 71.17            | -18.93            | 52.24            | 68.20    | -15.96 | PK               |
| Horizontal                       | 6039.14        | 59.27            | -18.93            | 40.34            | 54.00    | -13.66 | AV               |
| Horizontal                       | 11590.11       | 61.61            | -8.87             | 52.74            | 74.00    | -21.26 | PK               |
| Horizontal                       | 11590.11       | 49.34            | -8.87             | 40.47            | 54.00    | -13.53 | AV               |
| Horizontal                       | 17385.02       | 55.14            | -2.35             | 52.79            | 68.20    | -15.41 | PK               |
| Horizontal                       | 17385.02       | 44.98            | -2.35             | 42.63            | 54.00    | -11.37 | AV               |

Note: PK value is lower than the Average value limit, So average didn't record.

The 26.5-40G amplitude of spurious emissions that are attenuated by more than 20dB below the permissible value has no need to be reported.

Emission level (dBuV/m) = 20 log Emission level (uV/m).

Corrected Reading: Antenna Factor + Cable Loss + Read Level - Preamp Factor = Level.

Test Mode is MIMO Mode.

|            |                          |
|------------|--------------------------|
| Test Mode: | TX(5.8G) - 802.11ac-HT20 |
|------------|--------------------------|

| Polar<br>(H/V)                     | Fre-<br>quency<br>(MHz) | Reading<br>Level<br>(dBuV/m) | Correct<br>Factor<br>(dB) | Measure-<br>ment<br>(dBuV/m) | Limits<br>(dBuV/m) | Over<br>(dB) | Detector<br>Type |
|------------------------------------|-------------------------|------------------------------|---------------------------|------------------------------|--------------------|--------------|------------------|
| Low Channel (5745 MHz)-Above 1G    |                         |                              |                           |                              |                    |              |                  |
| Vertical                           | 4679.18                 | 74.87                        | -20.24                    | 54.63                        | 74.00              | -19.37       | PK               |
| Vertical                           | 4679.18                 | 59.94                        | -20.24                    | 39.70                        | 54.00              | -14.30       | AV               |
| Vertical                           | 11490.18                | 61.59                        | -8.79                     | 52.80                        | 68.20              | -15.40       | PK               |
| Vertical                           | 11490.18                | 49.06                        | -8.79                     | 40.27                        | 54.00              | -13.73       | AV               |
| Vertical                           | 17235.09                | 58.37                        | -3.18                     | 55.19                        | 68.20              | -13.01       | PK               |
| Vertical                           | 17235.09                | 44.35                        | -3.18                     | 41.17                        | 54.00              | -12.83       | AV               |
| Horizontal                         | 4679.18                 | 74.47                        | -20.24                    | 54.23                        | 74.00              | -19.77       | PK               |
| Horizontal                         | 4679.18                 | 59.12                        | -20.24                    | 38.88                        | 54.00              | -15.12       | AV               |
| Horizontal                         | 11490.13                | 63.78                        | -8.79                     | 54.99                        | 68.20              | -13.21       | PK               |
| Horizontal                         | 11490.13                | 49.59                        | -8.79                     | 40.80                        | 54.00              | -13.20       | AV               |
| Horizontal                         | 17235.08                | 59.61                        | -3.18                     | 56.43                        | 68.20              | -11.77       | PK               |
| Horizontal                         | 17235.08                | 44.38                        | -3.18                     | 41.20                        | 54.00              | -12.80       | AV               |
| middle Channel (5785 MHz)-Above 1G |                         |                              |                           |                              |                    |              |                  |
| Vertical                           | 4592.17                 | 73.18                        | -20.42                    | 52.77                        | 74.00              | -21.23       | PK               |
| Vertical                           | 4592.17                 | 59.99                        | -20.42                    | 39.57                        | 54.00              | -14.43       | AV               |
| Vertical                           | 11570.05                | 64.09                        | -8.86                     | 55.23                        | 68.20              | -12.97       | PK               |
| Vertical                           | 11570.05                | 49.06                        | -8.86                     | 40.20                        | 54.00              | -13.80       | AV               |
| Vertical                           | 17355.19                | 57.08                        | -2.52                     | 54.56                        | 68.20              | -13.64       | PK               |
| Vertical                           | 17355.19                | 44.35                        | -2.52                     | 41.83                        | 54.00              | -12.17       | AV               |
| Horizontal                         | 4592.01                 | 74.30                        | -20.42                    | 53.88                        | 74.00              | -20.12       | PK               |
| Horizontal                         | 4592.01                 | 59.41                        | -20.42                    | 38.99                        | 54.00              | -15.01       | AV               |
| Horizontal                         | 11570.16                | 63.94                        | -8.86                     | 55.08                        | 68.20              | -13.12       | PK               |
| Horizontal                         | 11570.16                | 49.83                        | -8.86                     | 40.97                        | 54.00              | -13.03       | AV               |
| Horizontal                         | 17355.00                | 57.69                        | -2.52                     | 55.17                        | 68.20              | -13.03       | PK               |
| Horizontal                         | 17355.00                | 44.61                        | -2.52                     | 42.09                        | 54.00              | -11.91       | AV               |
| High Channel (5825 MHz)-Above 1G   |                         |                              |                           |                              |                    |              |                  |
| Vertical                           | 6039.16                 | 71.98                        | -18.93                    | 53.05                        | 68.20              | -15.15       | PK               |
| Vertical                           | 6039.16                 | 60.00                        | -18.93                    | 41.07                        | 54.00              | -12.93       | AV               |
| Vertical                           | 11650.10                | 61.65                        | -8.92                     | 52.73                        | 74.00              | -21.27       | PK               |
| Vertical                           | 11650.10                | 49.90                        | -8.92                     | 40.98                        | 54.00              | -13.02       | AV               |
| Vertical                           | 17475.08                | 55.43                        | -1.86                     | 53.57                        | 68.20              | -14.63       | PK               |
| Vertical                           | 17475.08                | 44.88                        | -1.86                     | 43.02                        | 54.00              | -10.98       | AV               |
| Horizontal                         | 6039.10                 | 70.93                        | -18.93                    | 52.00                        | 68.20              | -16.20       | PK               |
| Horizontal                         | 6039.10                 | 59.94                        | -18.93                    | 41.01                        | 54.00              | -12.99       | AV               |
| Horizontal                         | 11650.00                | 62.82                        | -8.92                     | 53.90                        | 74.00              | -20.10       | PK               |
| Horizontal                         | 11650.00                | 49.51                        | -8.92                     | 40.59                        | 54.00              | -13.41       | AV               |
| Horizontal                         | 17475.11                | 58.53                        | -1.86                     | 56.67                        | 68.20              | -11.53       | PK               |
| Horizontal                         | 17475.11                | 44.24                        | -1.86                     | 42.38                        | 54.00              | -11.62       | AV               |

Note: PK value is lower than the Average value limit, So average didn't record.

The 26.5-40G amplitude of spurious emissions that are attenuated by more than 20dB below the permissible value has no need to be reported.

Emission level (dBuV/m) = 20 log Emission level (uV/m).

Corrected Reading: Antenna Factor + Cable Loss + Read Level - Preamp Factor = Level.

Test Mode is MIMO Mode.

|            |                          |
|------------|--------------------------|
| Test Mode: | TX(5.8G) - 802.11ac-HT40 |
|------------|--------------------------|

| Polar                            | Fre-<br>quency | Reading<br>Level | Correct<br>Factor | Measure-<br>ment | Limits   | Over   | Detector<br>Type |
|----------------------------------|----------------|------------------|-------------------|------------------|----------|--------|------------------|
| (H/V)                            | (MHz)          | (dBuV/m)         | (dB)              | (dBuV/m)         | (dBuV/m) | (dB)   |                  |
| Low Channel (5755 MHz)-Above 1G  |                |                  |                   |                  |          |        |                  |
| Vertical                         | 4679.18        | 71.60            | -20.24            | 51.36            | 74.00    | -22.64 | PK               |
| Vertical                         | 4679.18        | 59.40            | -20.24            | 39.16            | 54.00    | -14.84 | AV               |
| Vertical                         | 11510.16       | 60.89            | -8.81             | 52.08            | 74.00    | -21.92 | PK               |
| Vertical                         | 11510.16       | 49.34            | -8.81             | 40.53            | 54.00    | -13.47 | AV               |
| Vertical                         | 17265.06       | 56.81            | -3.01             | 53.80            | 68.20    | -14.40 | PK               |
| Vertical                         | 17265.06       | 44.02            | -3.01             | 41.01            | 54.00    | -12.99 | AV               |
| Horizontal                       | 4679.00        | 71.31            | -20.24            | 51.06            | 74.00    | -22.94 | PK               |
| Horizontal                       | 4679.00        | 59.64            | -20.24            | 39.40            | 54.00    | -14.60 | AV               |
| Horizontal                       | 11510.01       | 60.16            | -8.81             | 51.35            | 74.00    | -22.65 | PK               |
| Horizontal                       | 11510.01       | 49.80            | -8.81             | 40.99            | 54.00    | -13.01 | AV               |
| Horizontal                       | 17265.11       | 58.82            | -3.01             | 55.81            | 68.20    | -12.39 | PK               |
| Horizontal                       | 17265.11       | 44.07            | -3.01             | 41.06            | 54.00    | -12.94 | AV               |
| High Channel (5795 MHz)-Above 1G |                |                  |                   |                  |          |        |                  |
| Vertical                         | 6039.07        | 70.90            | -18.93            | 51.97            | 68.20    | -16.23 | PK               |
| Vertical                         | 6039.07        | 59.62            | -18.93            | 40.68            | 54.00    | -13.32 | AV               |
| Vertical                         | 11590.12       | 64.66            | -8.87             | 55.79            | 74.00    | -18.21 | PK               |
| Vertical                         | 11590.12       | 49.18            | -8.87             | 40.31            | 54.00    | -13.69 | AV               |
| Vertical                         | 17385.09       | 58.37            | -2.35             | 56.02            | 68.20    | -12.18 | PK               |
| Vertical                         | 17385.09       | 44.68            | -2.35             | 42.33            | 54.00    | -11.67 | AV               |
| Horizontal                       | 6039.06        | 73.38            | -18.93            | 54.44            | 68.20    | -13.76 | PK               |
| Horizontal                       | 6039.06        | 59.36            | -18.93            | 40.42            | 54.00    | -13.58 | AV               |
| Horizontal                       | 11590.01       | 63.81            | -8.87             | 54.94            | 74.00    | -19.06 | PK               |
| Horizontal                       | 11590.01       | 49.17            | -8.87             | 40.30            | 54.00    | -13.70 | AV               |
| Horizontal                       | 17385.16       | 59.73            | -2.35             | 57.38            | 68.20    | -10.82 | PK               |
| Horizontal                       | 17385.16       | 44.74            | -2.35             | 42.39            | 54.00    | -11.61 | AV               |

Note: PK value is lower than the Average value limit, So average didn't record.

The 26.5-40G amplitude of spurious emissions that are attenuated by more than 20dB below the permissible value has no need to be reported.

Emission level (dBuV/m) = 20 log Emission level (uV/m).

Corrected Reading: Antenna Factor + Cable Loss + Read Level - Preamp Factor = Level.

Test Mode is MIMO Mode.

|            |                          |
|------------|--------------------------|
| Test Mode: | TX(5.8G) - 802.11ac-HT80 |
|------------|--------------------------|

| Polar<br>(H/V)      | Fre-<br>quency<br>(MHz) | Reading<br>Level<br>(dBuV/m) | Correct<br>Factor<br>(dB) | Measure-<br>ment<br>(dBuV/m) | Limits<br>(dBuV/m) | Over<br>(dB) | Detector<br>Type |
|---------------------|-------------------------|------------------------------|---------------------------|------------------------------|--------------------|--------------|------------------|
| (5775 MHz)-Above 1G |                         |                              |                           |                              |                    |              |                  |
| Vertical            | 4679.08                 | 70.20                        | -20.24                    | 49.96                        | 74.00              | -24.04       | PK               |
| Vertical            | 4679.08                 | 59.17                        | -20.24                    | 38.93                        | 54.00              | -15.07       | AV               |
| Vertical            | 11550.16                | 64.72                        | -8.84                     | 55.88                        | 74.00              | -18.12       | PK               |
| Vertical            | 11550.16                | 49.43                        | -8.84                     | 40.59                        | 54.00              | -13.41       | AV               |
| Vertical            | 17325.12                | 59.03                        | -2.68                     | 56.35                        | 68.20              | -11.85       | PK               |
| Vertical            | 17325.12                | 44.99                        | -2.68                     | 42.31                        | 54.00              | -11.69       | AV               |
| Horizontal          | 4679.06                 | 70.81                        | -20.24                    | 50.57                        | 74.00              | -23.43       | PK               |
| Horizontal          | 4679.06                 | 59.40                        | -20.24                    | 39.15                        | 54.00              | -14.85       | AV               |
| Horizontal          | 11550.12                | 64.12                        | -8.84                     | 55.28                        | 74.00              | -18.72       | PK               |
| Horizontal          | 11550.12                | 49.29                        | -8.84                     | 40.45                        | 54.00              | -13.55       | AV               |
| Horizontal          | 17325.09                | 58.97                        | -2.68                     | 56.29                        | 68.20              | -11.91       | PK               |
| Horizontal          | 17325.09                | 44.84                        | -2.68                     | 42.16                        | 54.00              | -11.84       | AV               |

Note: PK value is lower than the Average value limit, So average didn't record.  
 The 26.5-40G amplitude of spurious emissions that are attenuated by more than 20dB below the permissible value has no need to be reported.  
 Emission level (dBuV/m) = 20 log Emission level (uV/m).  
 Corrected Reading: Antenna Factor + Cable Loss + Read Level - Preamp Factor = Level.  
 Test Mode is MIMO Mode.

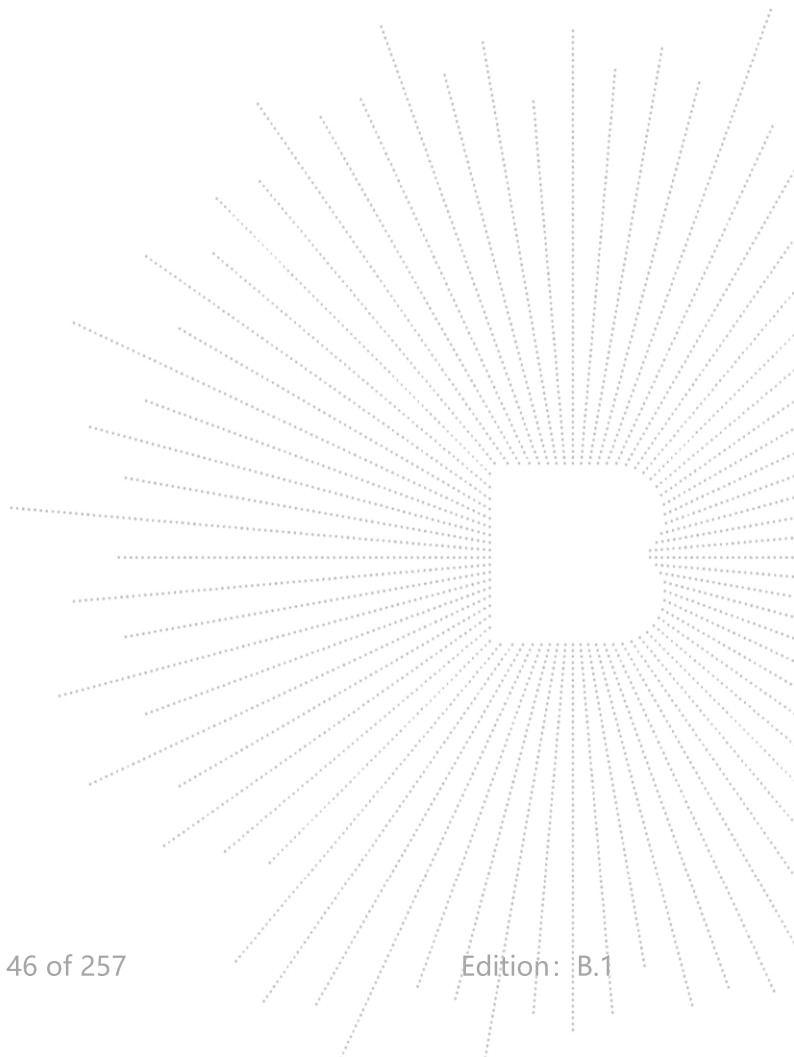

## 8. Power Spectral Density Test

### 8.1 Block Diagram Of Test Setup



### 8.2 Limit

For the band 5.15-5.25 GHz,

(i) For an outdoor access point operating in the band 5.15-5.25 GHz, the maximum power spectral density shall not exceed 17 dBm in any 1 megahertz band. If transmitting antennas of directional gain greater than 6 dBi are used, both the maximum conducted output power and the maximum power spectral density shall be reduced by the amount in dB that the directional gain of the antenna exceeds 6 dBi. The maximum e.i.r.p. at any elevation angle above 30 degrees as measured from the horizon must not exceed 125 mW (21 dBm).

(ii) For an indoor access point operating in the band 5.15-5.25 GHz, the maximum power spectral density shall not exceed 17 dBm in any 1 megahertz band. If transmitting antennas of directional gain greater than 6 dBi are used, both the maximum conducted output power and the maximum power spectral density shall be reduced by the amount in dB that the directional gain of the antenna exceeds 6 dBi.

(iii) For fixed point-to-point access points operating in the band 5.15-5.25 GHz, the maximum power spectral density shall not exceed 17 dBm in any 1 megahertz band. Fixed point-to-point U-NII devices may employ antennas with directional gain up to 23 dBi without any corresponding reduction in the maximum conducted output power or maximum power spectral density. For fixed point-to-point transmitters that employ a directional antenna gain greater than 23 dBi, a 1 dB reduction in maximum conducted output power and maximum power spectral density is required for each 1 dB of antenna gain in excess of 23 dBi. Fixed, point-to-point operations exclude the use of point-to-multipoint systems, omnidirectional applications, and multiple collocated transmitters transmitting the same information. The operator of the U-NII device, or if the equipment is professionally installed, the installer, is responsible for ensuring that systems employing high gain directional antennas are used exclusively for fixed, point-to-point operations.

(iv) For client devices in the 5.15-5.25 GHz band, the maximum power spectral density shall not exceed 11 dBm in any 1 megahertz band. If transmitting antennas of directional gain greater than 6 dBi are used, both the maximum conducted output power and the maximum power spectral density shall be reduced by the amount in dB that the directional gain of the antenna exceeds 6 dBi.

For the band 5.725-5.85 GHz

For the 5.25-5.35 GHz and 5.47-5.725 GHz bands

(b) (2) The maximum conducted output power over the frequency bands of operation shall not exceed the lesser of 250 mW or  $11 \text{ dBm} + 10 \log B$ , where B is the 26 dB emission bandwidth in megahertz. In addition, the maximum power spectral density shall not exceed 11 dBm in any 1 megahertz band. If transmitting antennas of directional gain greater than 6 dBi are used, both the maximum conducted output power and the maximum power spectral density shall be reduced by the amount in dB that the directional gain of the antenna exceeds 6 dBi.

(3) For the band 5.725-5.85 GHz, the maximum power spectral density shall not exceed 30 dBm in any 500-kHz band. If transmitting antennas of directional gain greater than 6 dBi are used, both the maximum conducted output power and the maximum power spectral density shall be reduced by the amount in dB that the directional gain of the antenna exceeds 6 dBi.

### 8.3 Test Procedure

For devices operating in the bands 5.15-5.25 GHz, 5.25-5.35 GHz, and 5.47-5.725 GHz, the above procedures make use of 1 MHz RBW to satisfy directly the 1 MHz reference bandwidth specified in § 15.407(a)(5). For devices operating in the band 5.725-5.85 GHz, the rules specify a measurement bandwidth of 500 kHz. Many spectrum analyzers do not have 500 kHz RBW, thus a narrower RBW may need to be used. The rules permit the use of a RBWs less than 1 MHz, or 500 kHz, "provided that the measured power is integrated over the full reference bandwidth" to show the total power over the specified measurement bandwidth (i.e., 1 MHz, or 500 kHz). If measurements are performed using a reduced resolution bandwidth (< 1 MHz, or < 500 kHz) and integrated over 1 MHz, or 500 kHz bandwidth, the following adjustments to the procedures apply:

- a) Set  $RBW \geq 1/T$ , where T is defined in section II.B.I.a).
- b) Set  $VBW \geq 3 RBW$ .
- c) If measurement bandwidth of Maximum PSD is specified in 500 kHz, add  $10\log(500\text{kHz}/RBW)$  to the measured result, whereas  $RBW (< 500 \text{ KHz})$  is the reduced resolution bandwidth of the spectrum analyzer set during measurement.
- d) If measurement bandwidth of Maximum PSD is specified in 1 MHz, add  $10\log(1\text{MHz}/RBW)$  to the measured result, whereas  $RBW (< 1 \text{ MHz})$  is the reduced resolution bandwidth of spectrum analyzer set during measurement.
- e) Care must be taken to ensure that the measurements are performed during a period of continuous transmission or are corrected upward for duty cycle.

Note: As a practical matter, it is recommended to use reduced RBW of 100 KHz for the sections 5.c) and 5.d) above, since  $RBW=100 \text{ KHz}$  is available on nearly all spectrum analyzers.

### 8.4 EUT Operating Conditions

The EUT was configured for testing in a typical fashion (as a customer would normally use it). The EUT has been programmed to continuously transmit during test. This operating condition was tested and used to collect the included data.



## 8.5 Test Result

|              |                |                    |              |
|--------------|----------------|--------------------|--------------|
| Temperature: | 26 °C          | Relative Humidity: | 54%          |
| Pressure:    | 101KPa         | Test Voltage:      | AC 120V/60Hz |
| Test Mode:   | (5180-5240MHz) |                    |              |

| Condition | Mode | Frequency (MHz) | Conducted PSD (dBm/MHz) |       | Total (dBm/MHz) | Limit (dBm/MHz) | Verdict |
|-----------|------|-----------------|-------------------------|-------|-----------------|-----------------|---------|
|           |      |                 | Ant A                   | Ant B |                 |                 |         |
| NVNT      | a    | 5180            | 0.88                    | 0.59  | /               | 11              | Pass    |
| NVNT      | a    | 5200            | 0.45                    | 0.1   | /               | 11              | Pass    |
| NVNT      | a    | 5240            | <b>1.42</b>             | -0.38 | /               | 11              | Pass    |
| NVNT      | n20  | 5180            | 0.05                    | -0.99 | 2.57            | 11              | Pass    |
| NVNT      | n20  | 5200            | -0.27                   | -1.02 | 2.38            | 11              | Pass    |
| NVNT      | n20  | 5240            | 0.53                    | -1.49 | 2.65            | 11              | Pass    |
| NVNT      | n40  | 5190            | -3.12                   | -5.35 | -1.08           | 11              | Pass    |
| NVNT      | n40  | 5230            | -3.45                   | -4.7  | -1.02           | 11              | Pass    |
| NVNT      | ac20 | 5180            | -0.24                   | -1.21 | 2.31            | 11              | Pass    |
| NVNT      | ac20 | 5200            | -0.26                   | -1.25 | 2.28            | 11              | Pass    |
| NVNT      | ac20 | 5240            | 0.06                    | -1.92 | 2.19            | 11              | Pass    |
| NVNT      | ac40 | 5190            | -4.22                   | -5.55 | -1.82           | 11              | Pass    |
| NVNT      | ac40 | 5230            | -3.27                   | -5.96 | -1.40           | 11              | Pass    |
| NVNT      | ac80 | 5210            | -7.48                   | -9.26 | -5.27           | 11              | Pass    |

## Note:

Antenna A gain:2.55 dBi, Antenna B gain: 2.55 dBi, Directional gain=[ GainANT + 10 log(NANT/NSS) dBi]  
 =5.56 dBi<6dBi  
 EIRP Limit=11 dBi

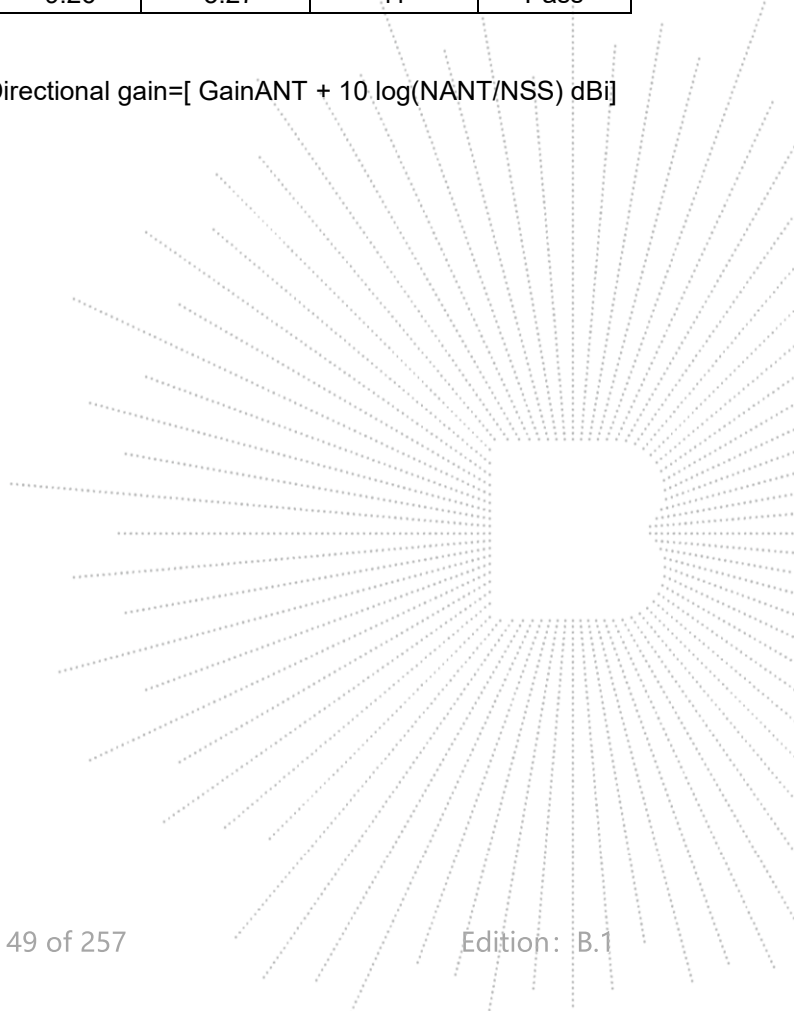

Note: A(B) Represent the value of antenna A and B, The worst data is Antenna A, only shown Antenna A Plot.

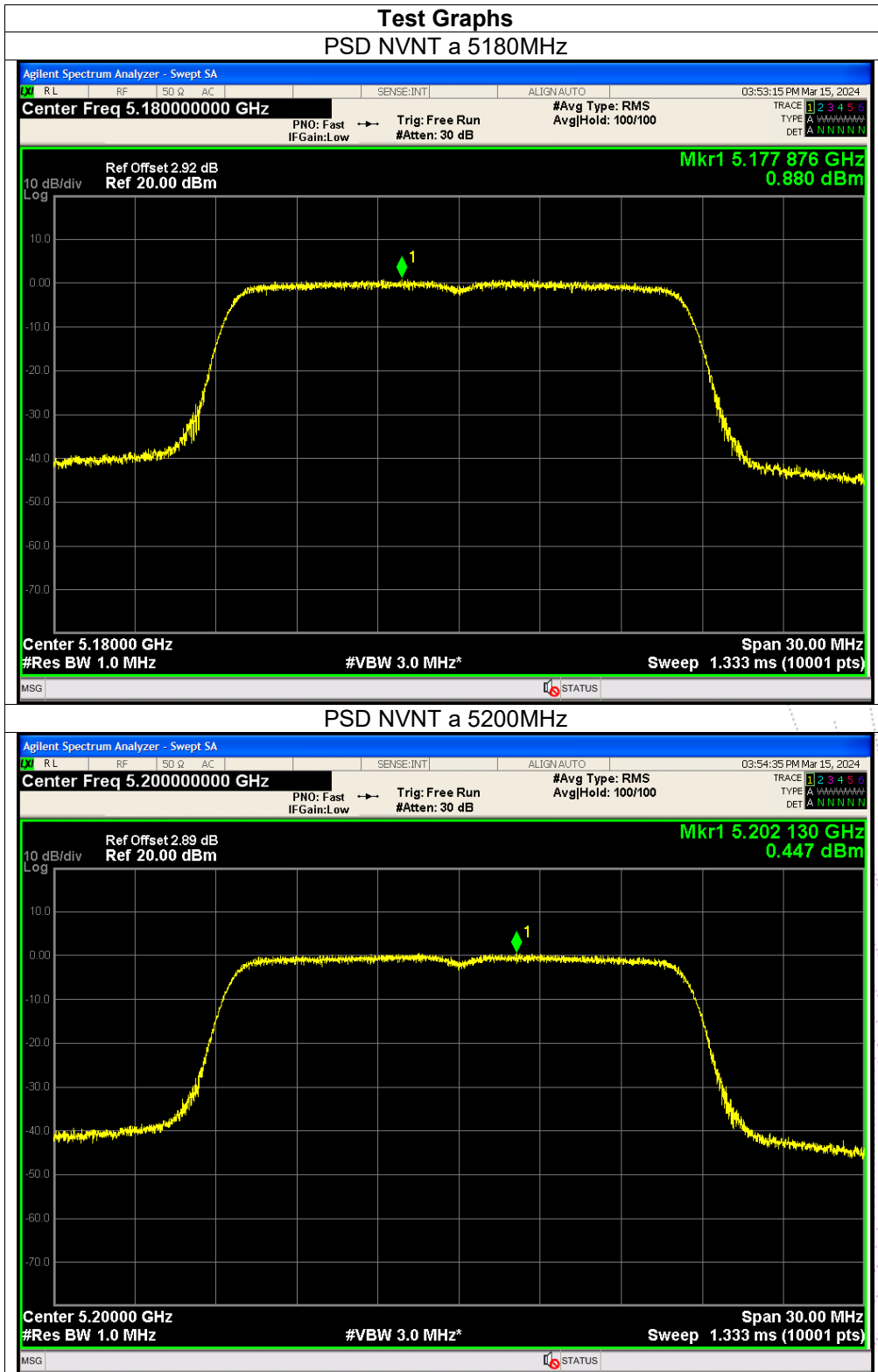

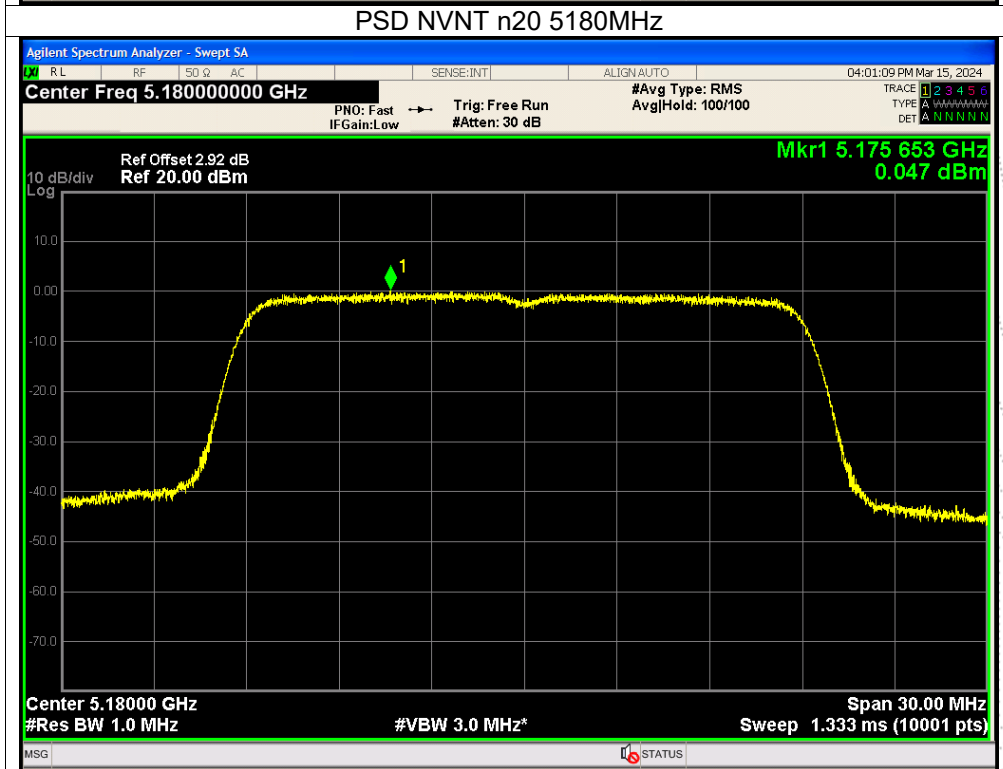
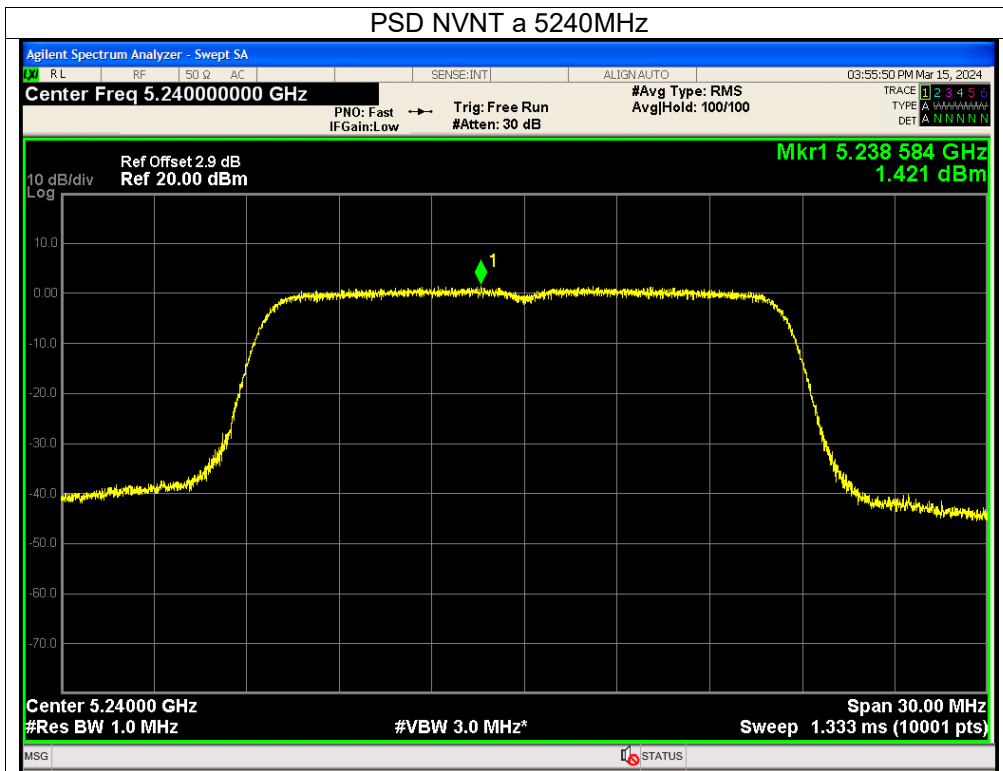

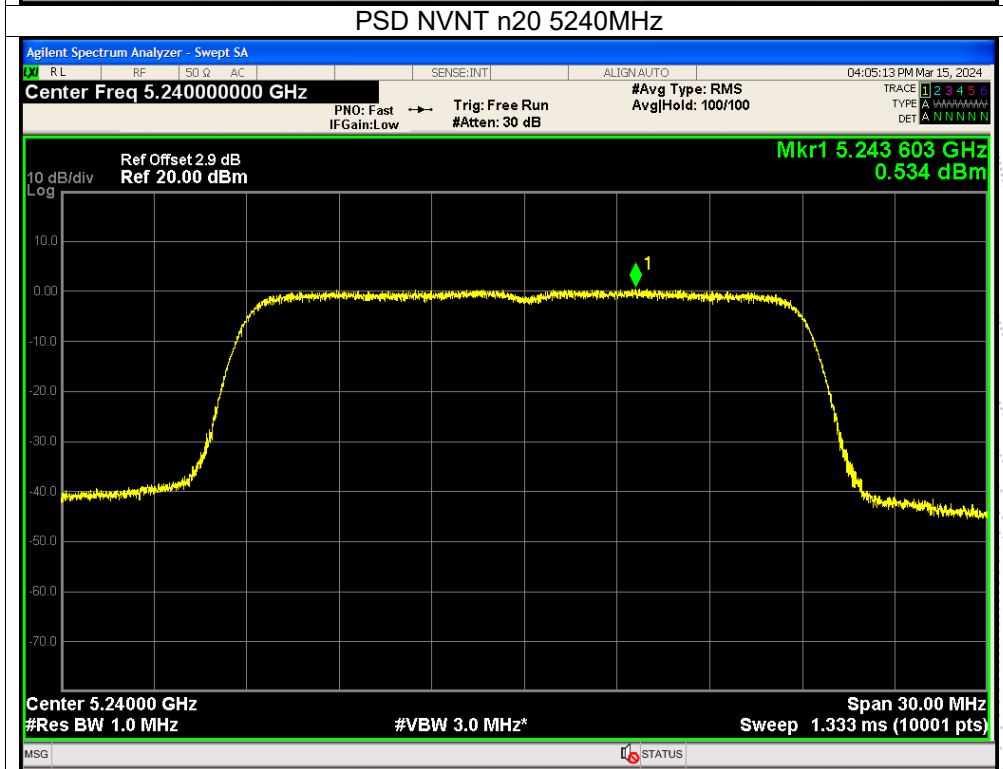
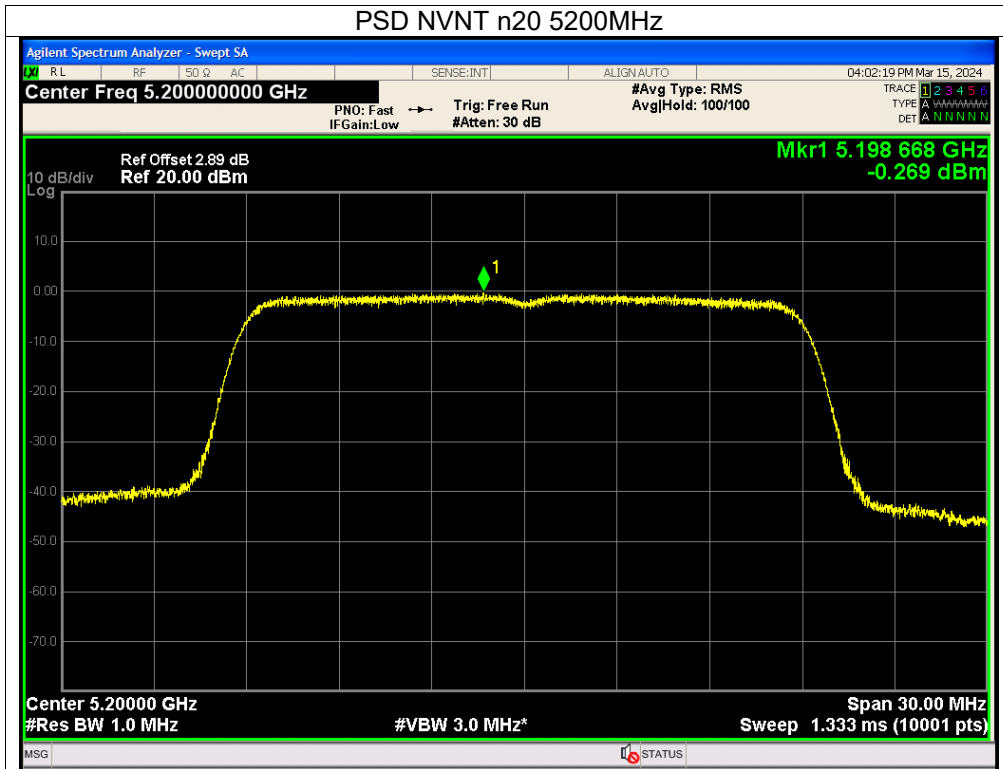

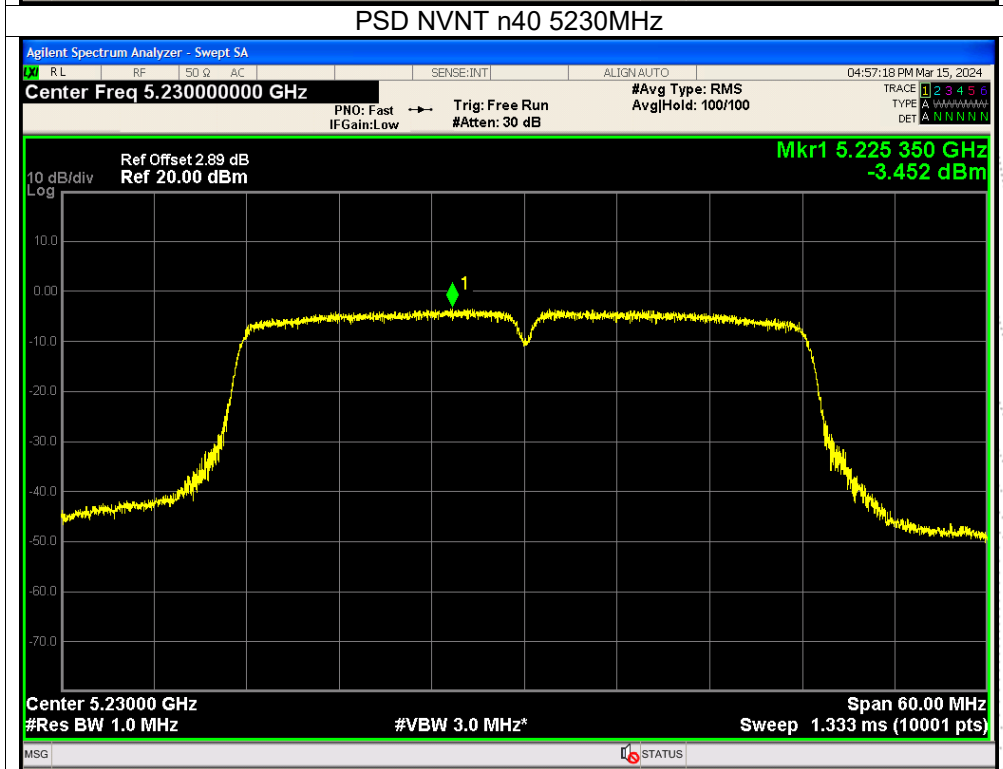
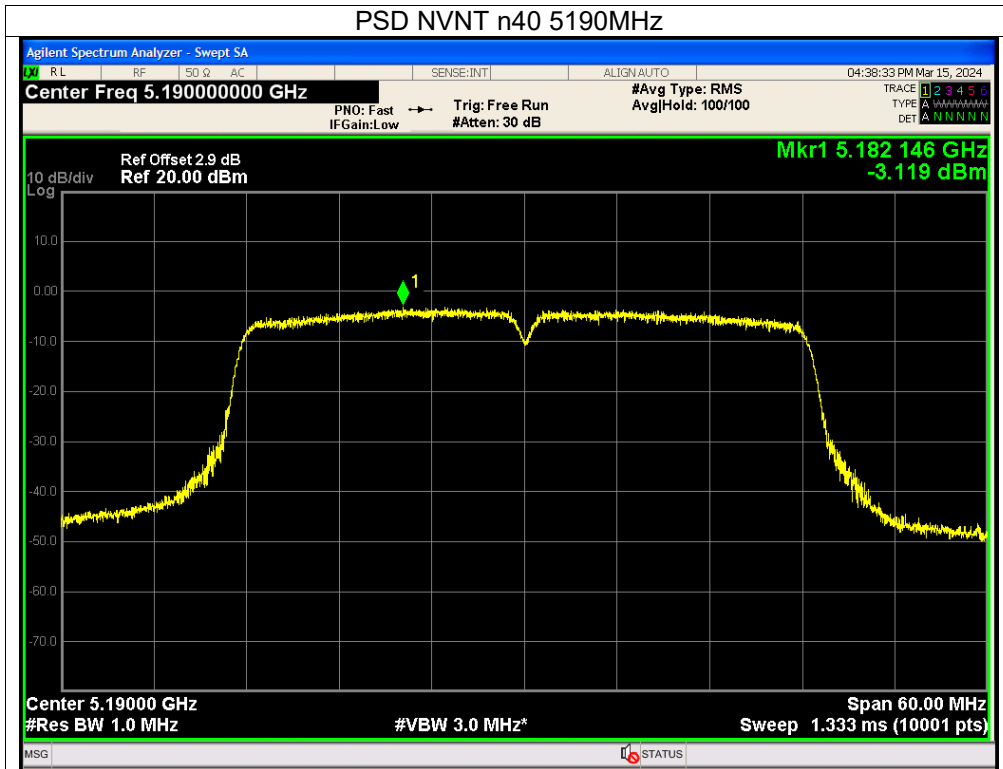

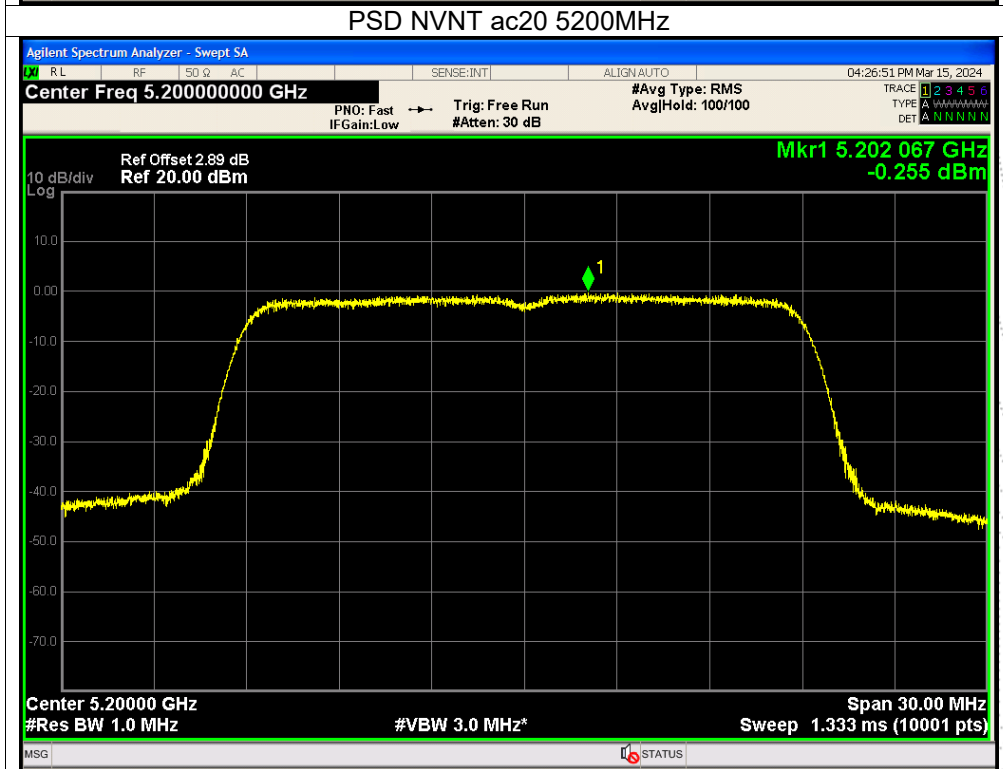
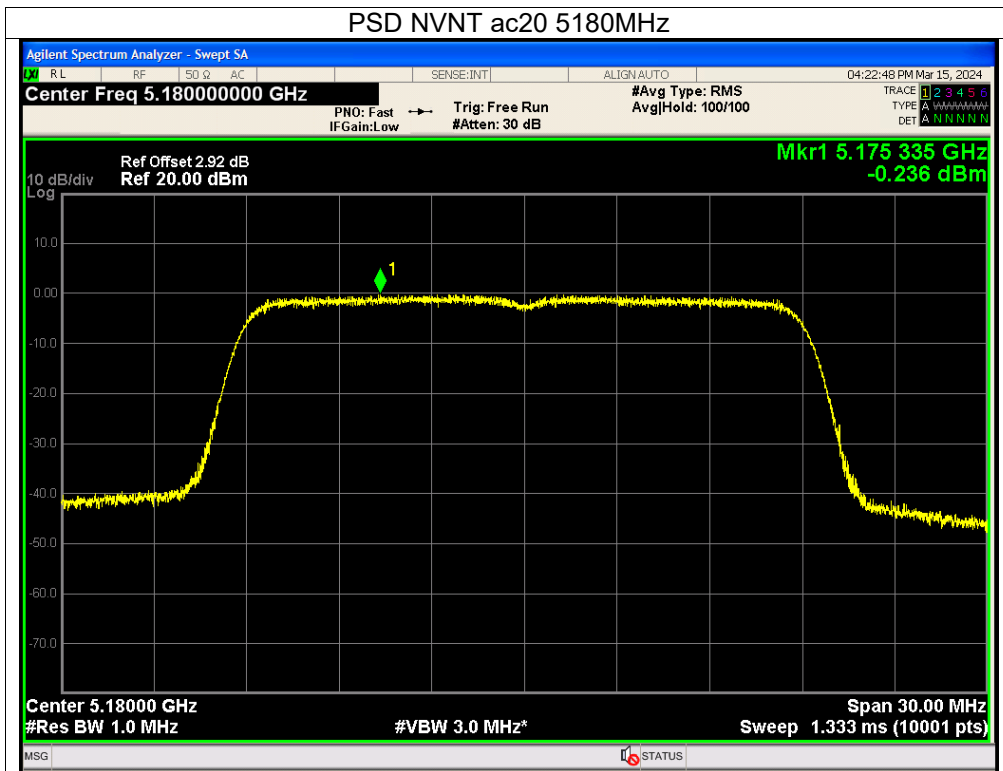

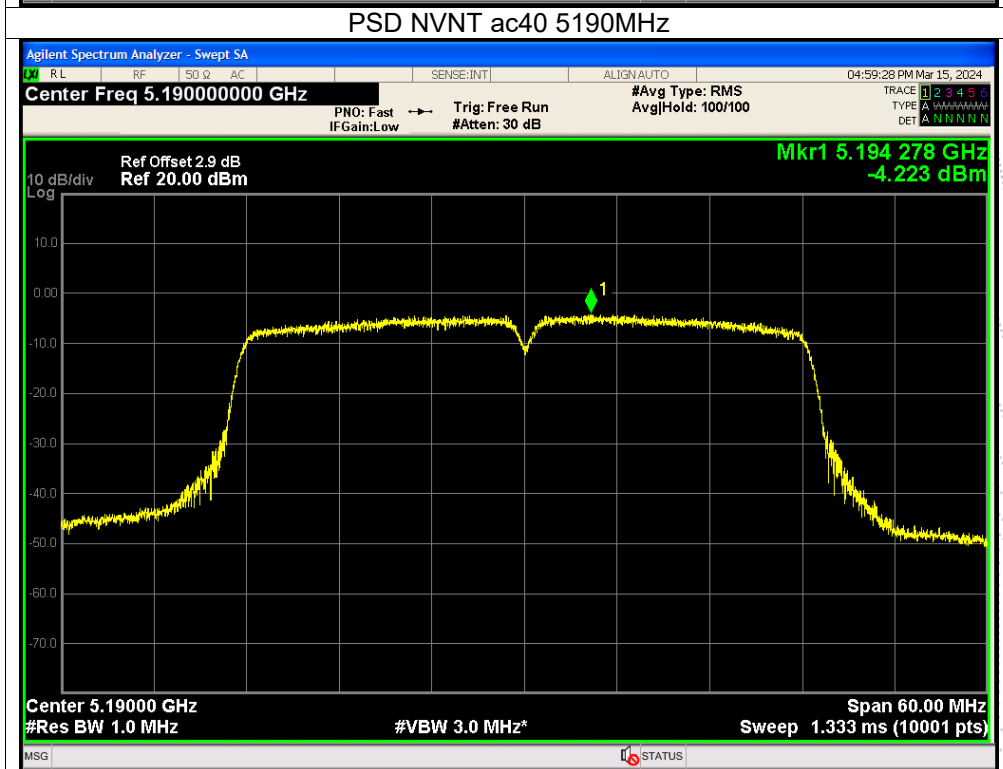
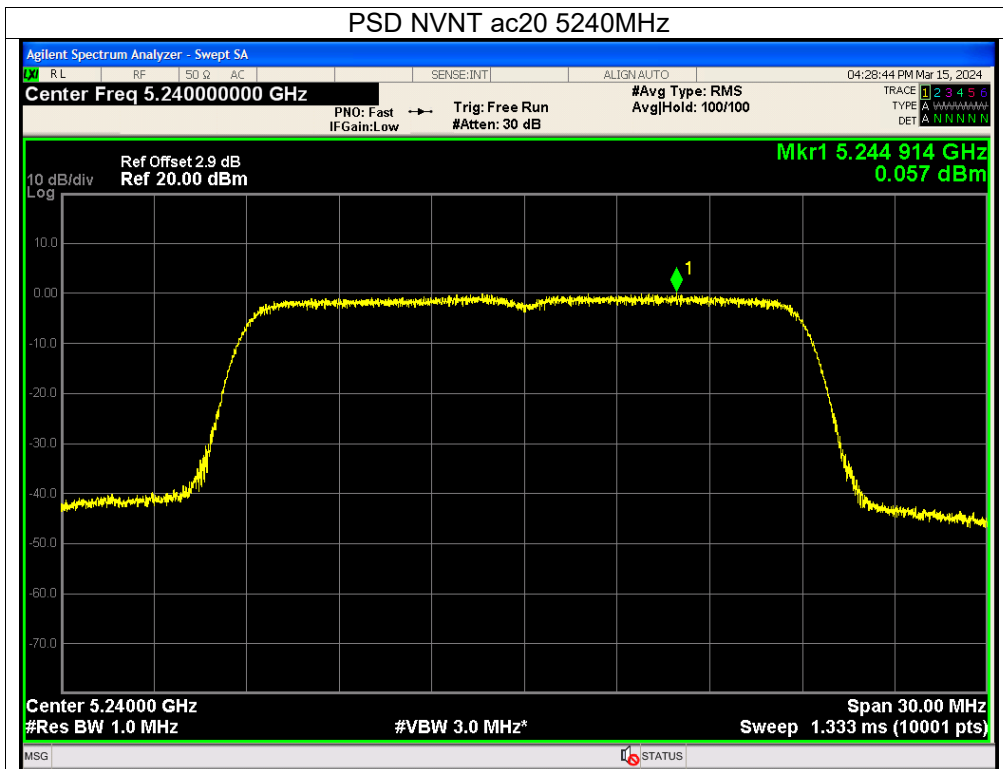

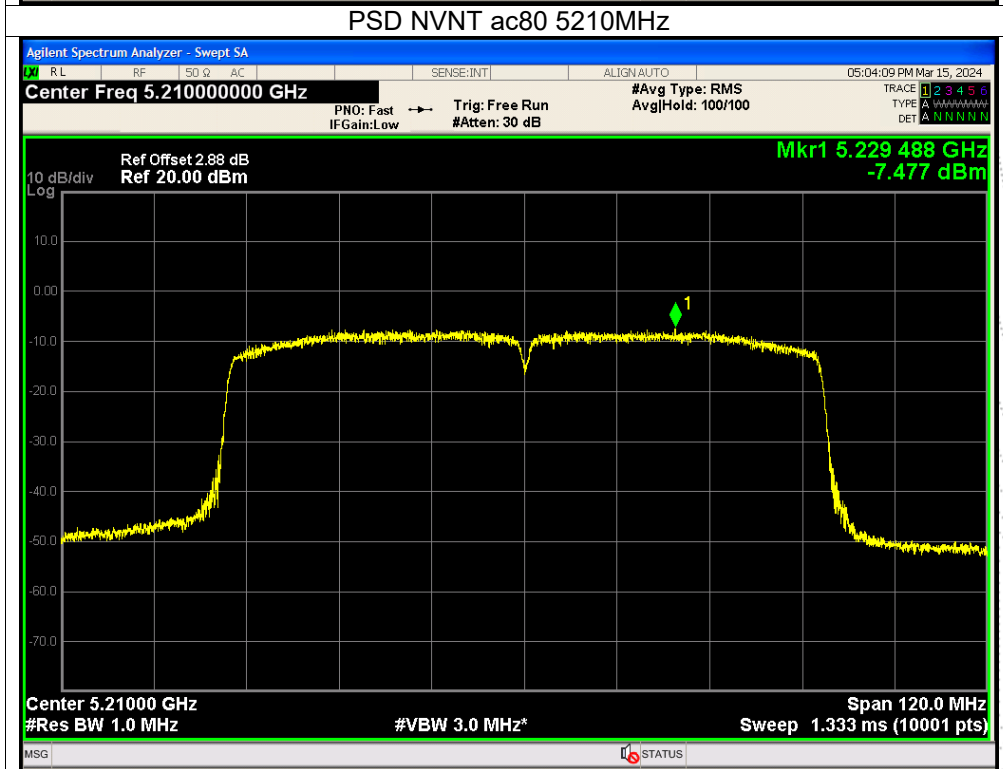
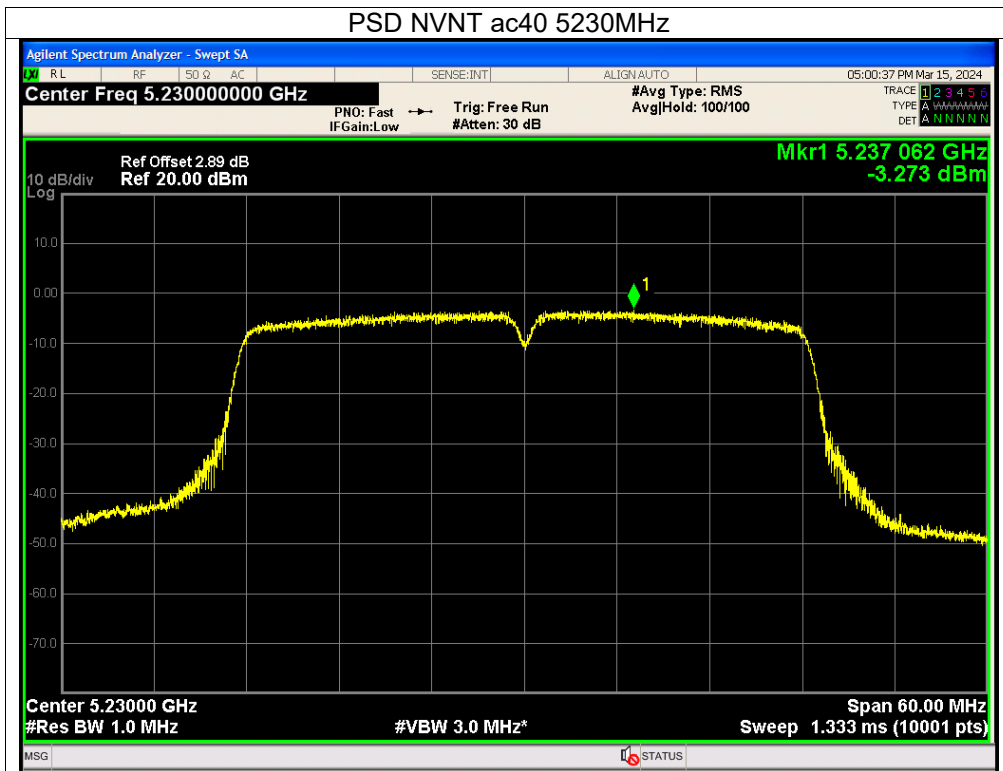



|              |                |                    |              |
|--------------|----------------|--------------------|--------------|
| Temperature: | 26 °C          | Relative Humidity: | 54%          |
| Pressure:    | 101KPa         | Test Voltage:      | AC 120V/60Hz |
| Test Mode:   | (5260-5320MHz) |                    |              |

| Condition | Mode | Frequency (MHz) | Conducted PSD (dBm/MHz) |        | Total (dBm/MHz) | Limit (dBm/MHz) | Verdict |
|-----------|------|-----------------|-------------------------|--------|-----------------|-----------------|---------|
|           |      |                 | Ant A                   | Ant B  |                 |                 |         |
| NVNT      | a    | 5260            | -1.18                   | -1.31  | /               | 11              | Pass    |
| NVNT      | a    | 5280            | <b>-0.81</b>            | -1.78  | /               | 11              | Pass    |
| NVNT      | a    | 5320            | -2.07                   | -2.25  | /               | 11              | Pass    |
| NVNT      | n20  | 5260            | -2.59                   | -1.99  | 0.73            | 11              | Pass    |
| NVNT      | n20  | 5280            | -2.69                   | -2.61  | 0.36            | 11              | Pass    |
| NVNT      | n20  | 5320            | -4.59                   | -2.31  | -0.29           | 11              | Pass    |
| NVNT      | n40  | 5270            | -7.17                   | -7.27  | -4.21           | 11              | Pass    |
| NVNT      | n40  | 5310            | -8.27                   | -6.62  | -4.36           | 11              | Pass    |
| NVNT      | ac20 | 5260            | -2.88                   | -3.39  | -0.12           | 11              | Pass    |
| NVNT      | ac20 | 5280            | -2.72                   | -2.9   | 0.20            | 11              | Pass    |
| NVNT      | ac20 | 5320            | -4.36                   | -2.27  | -0.18           | 11              | Pass    |
| NVNT      | ac40 | 5270            | -7.37                   | -7.28  | -4.31           | 11              | Pass    |
| NVNT      | ac40 | 5310            | -8.74                   | -6.27  | -4.32           | 11              | Pass    |
| NVNT      | ac80 | 5290            | -11.46                  | -11.09 | -8.26           | 11              | Pass    |

**Note:**

Antenna A gain: 2.55 dBi, Antenna B gain: 2.55 dBi, Directional gain=[ GainANT + 10 log(NANT/NSS) dBi]  
 =5.56 dBi<6dBi  
 Limit=11 dBi

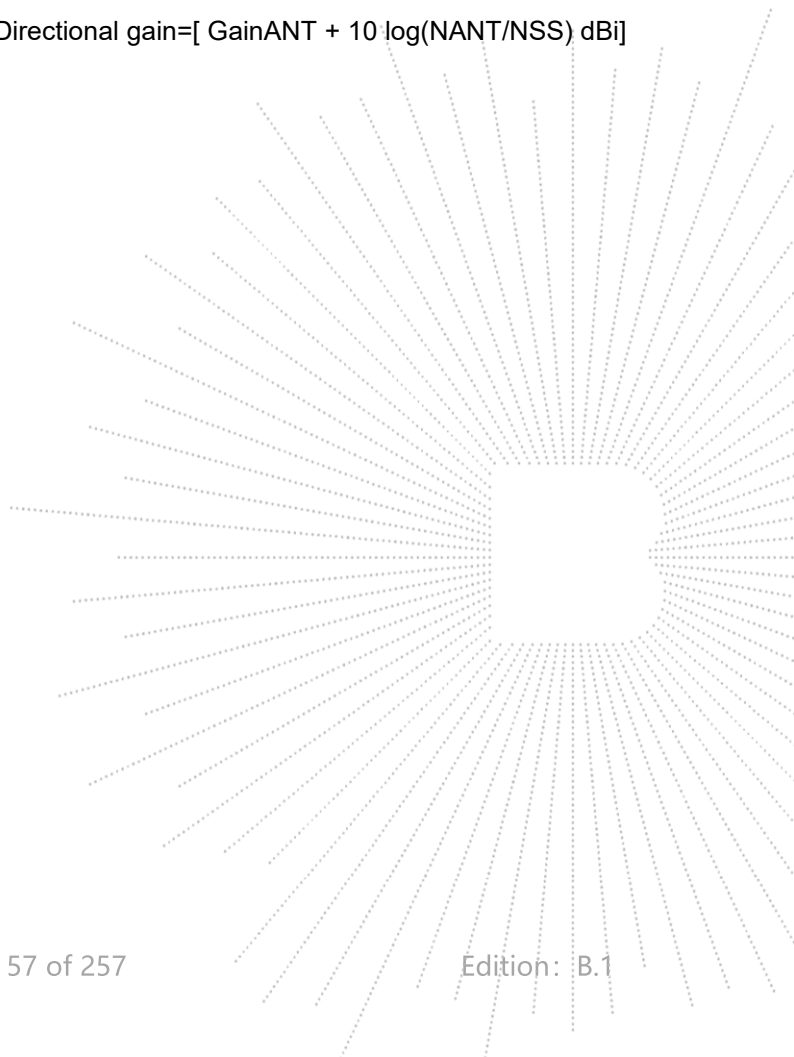

Note: A(B) Represent the value of antenna A and B, The worst data is Antenna A, only shown Antenna A Plot.

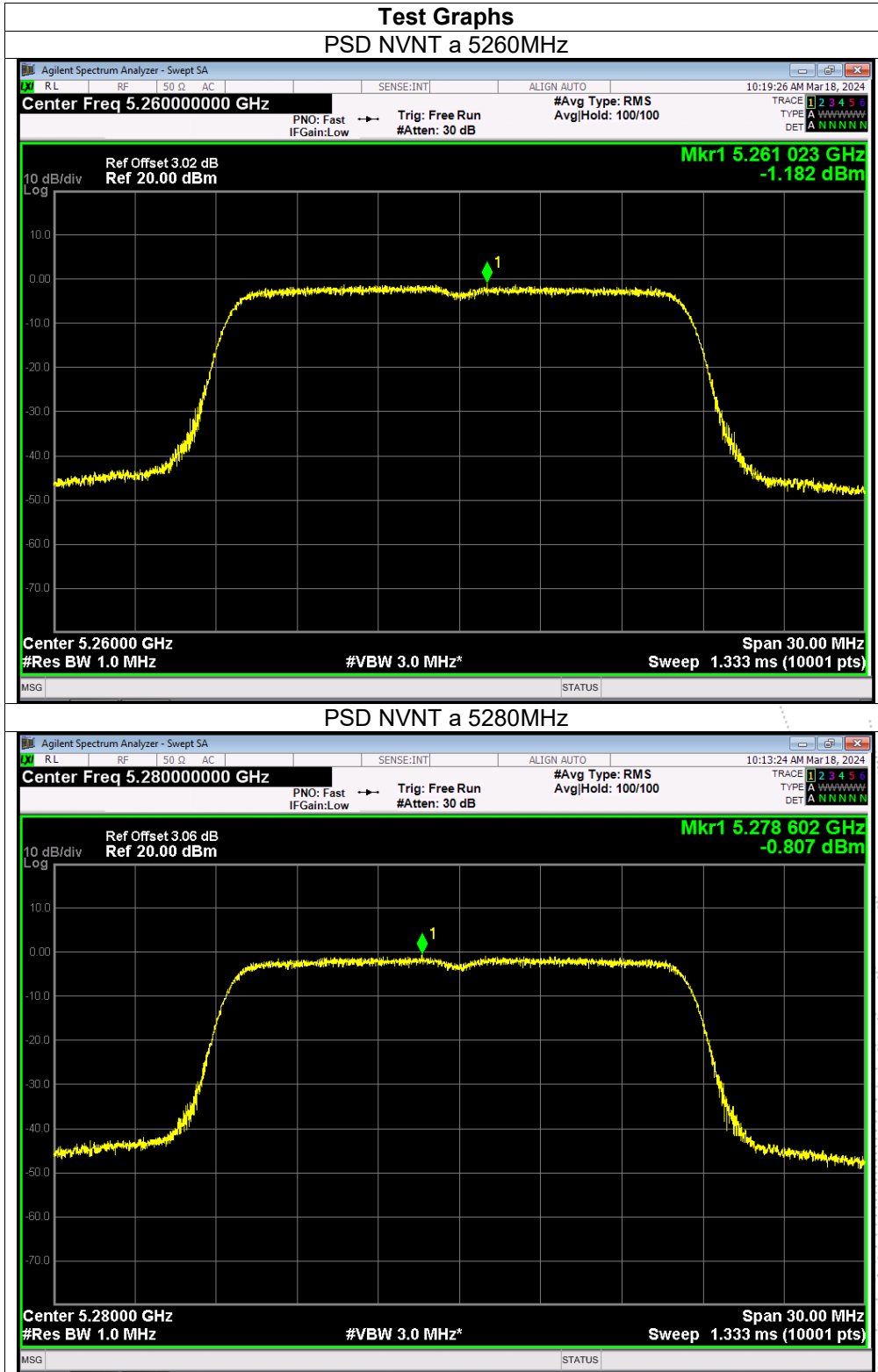

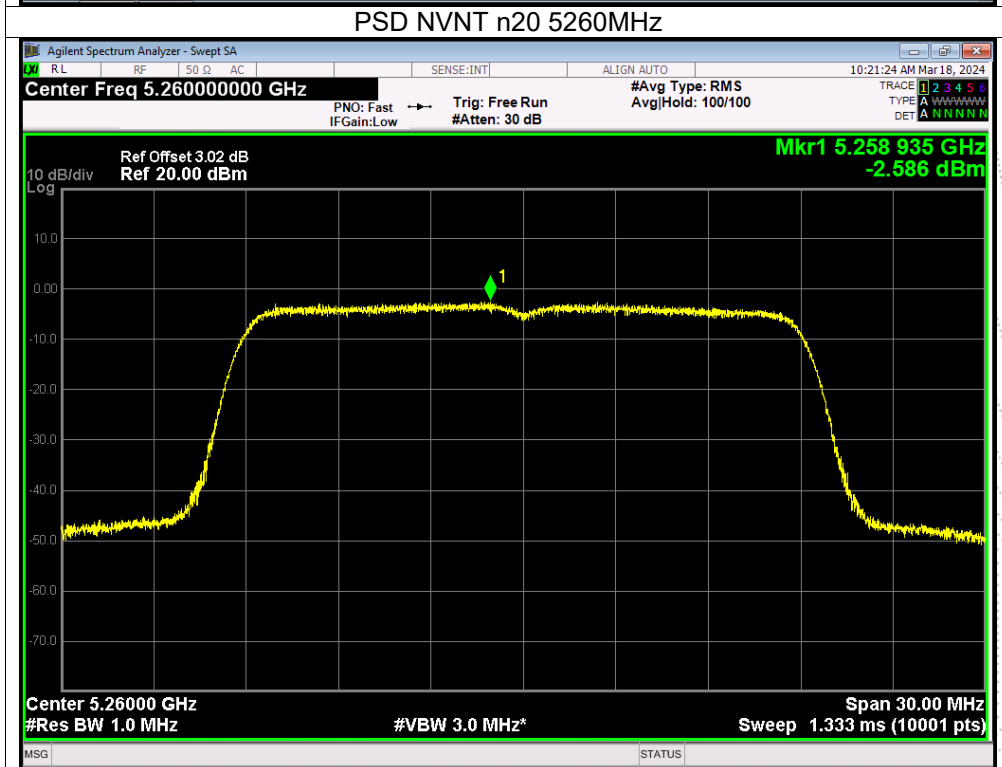
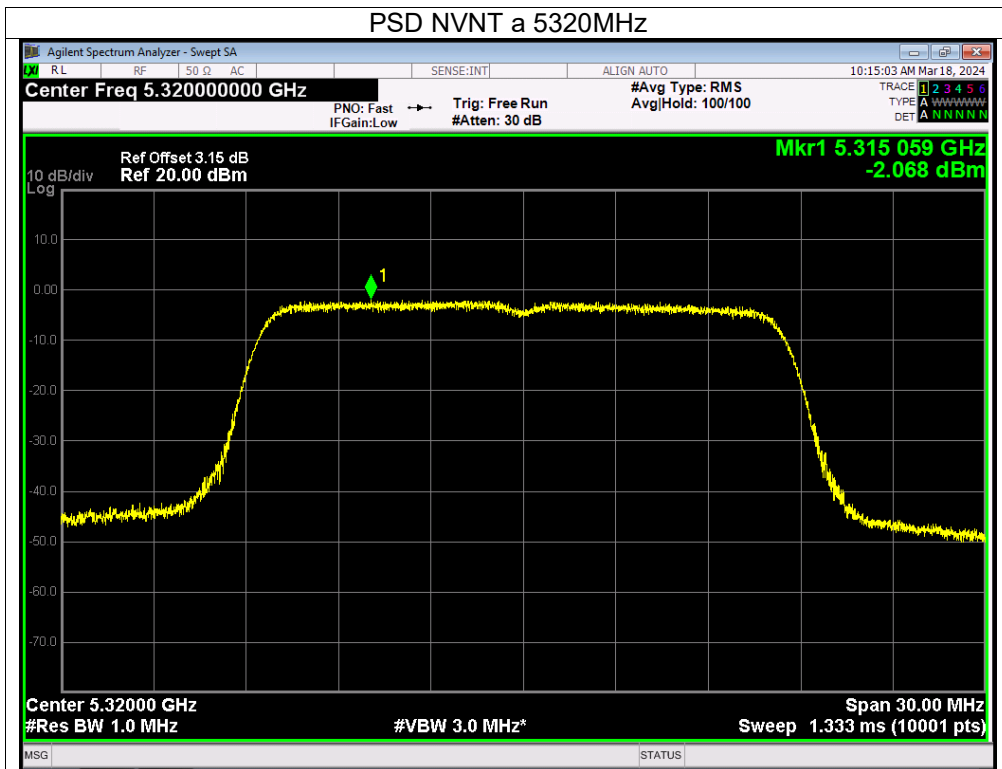

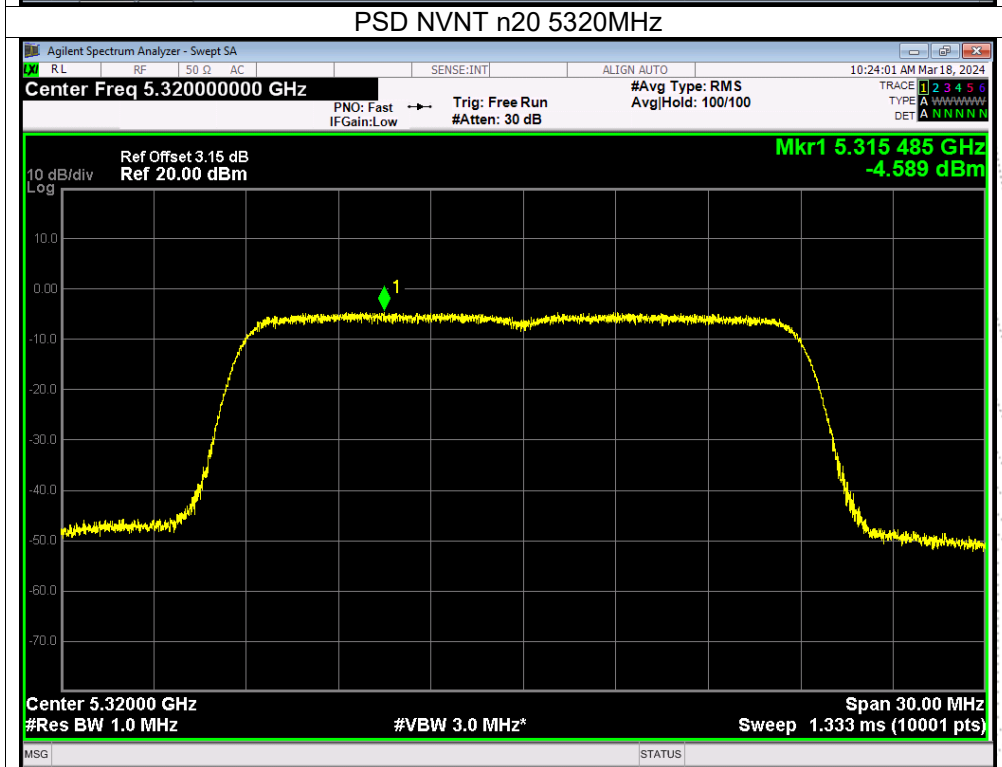
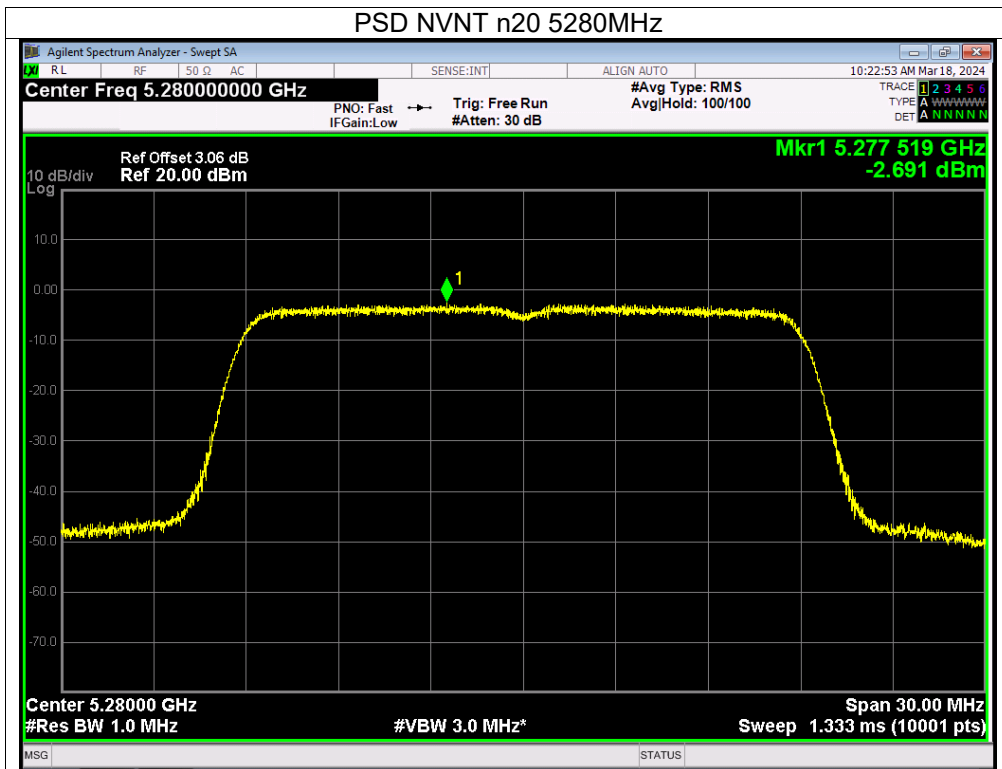

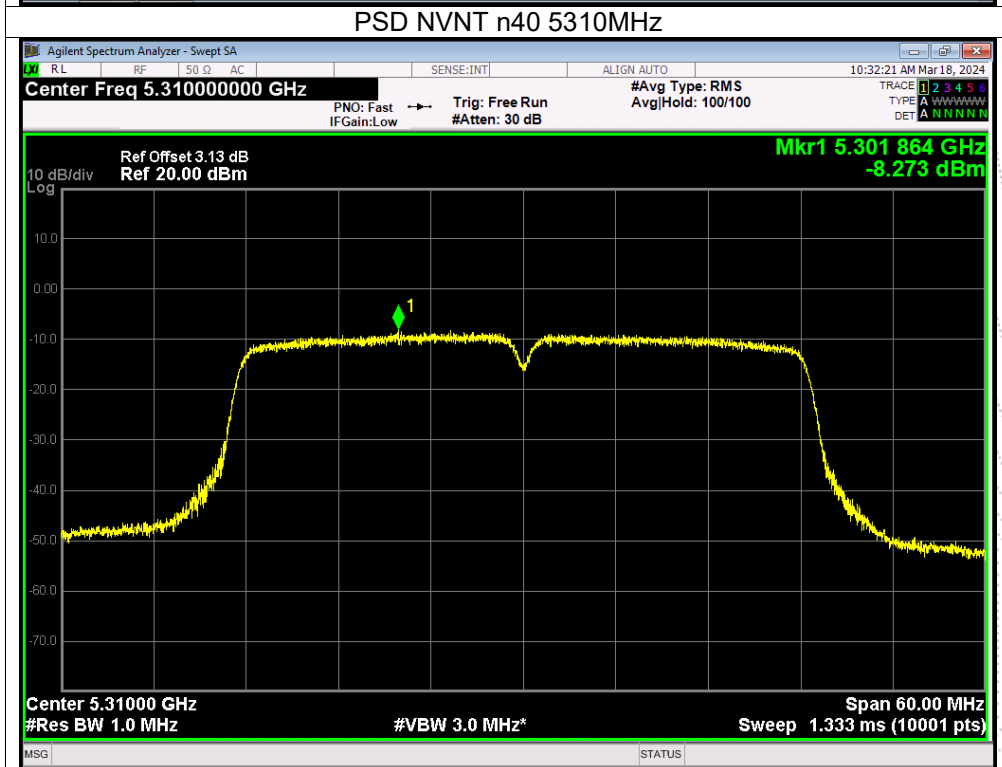
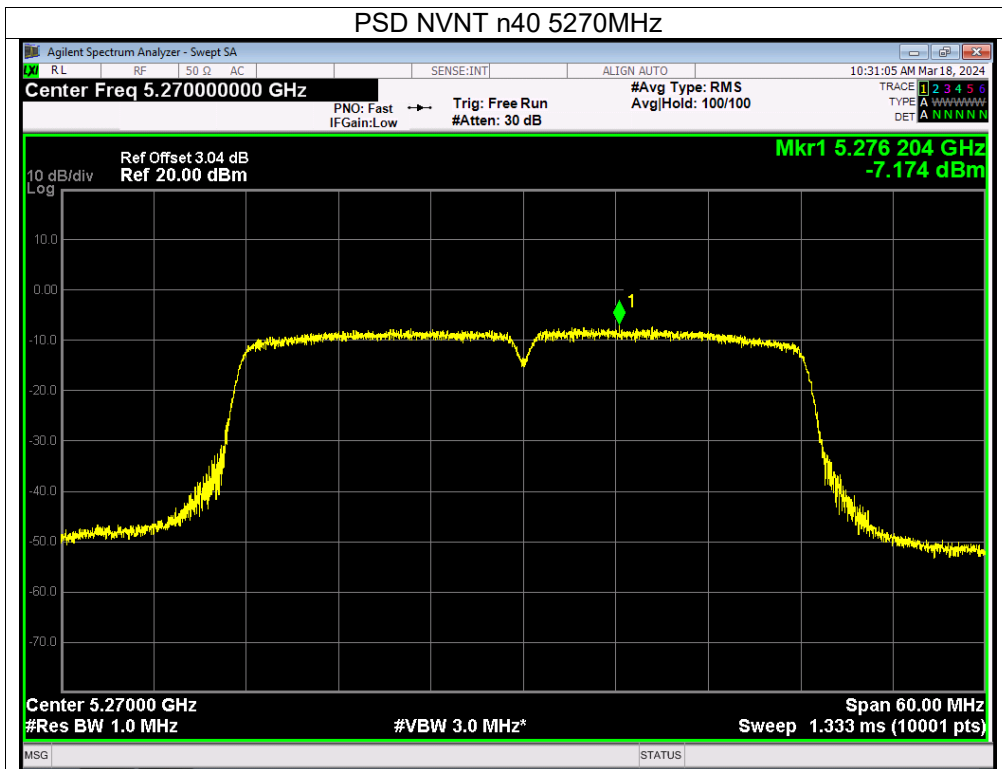

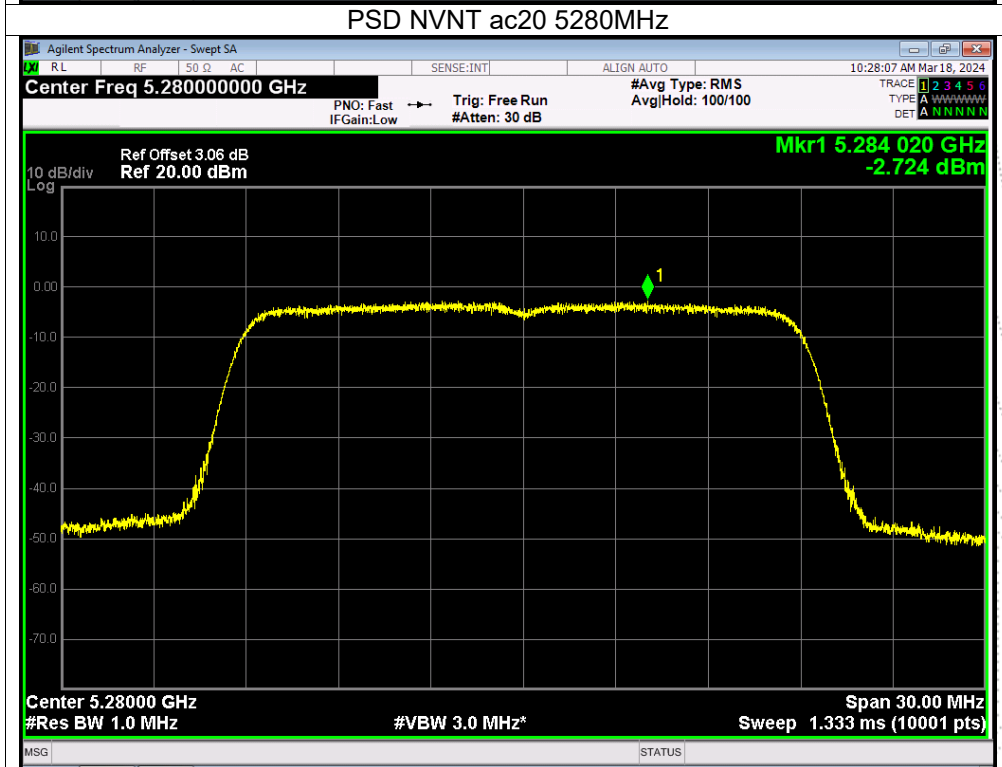
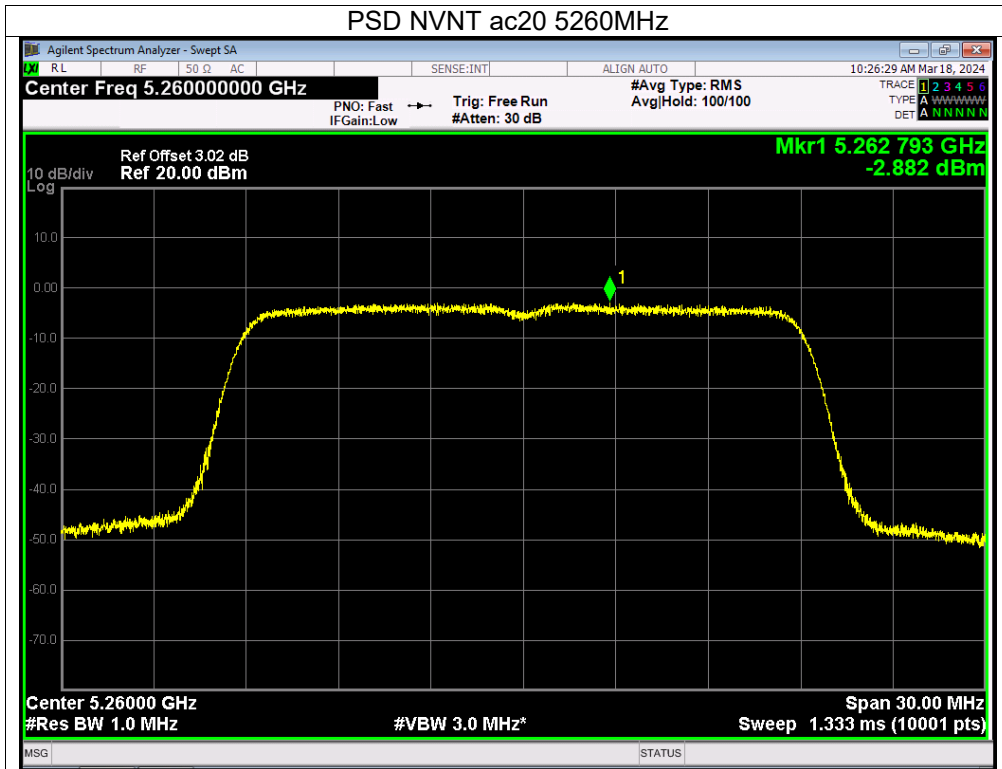

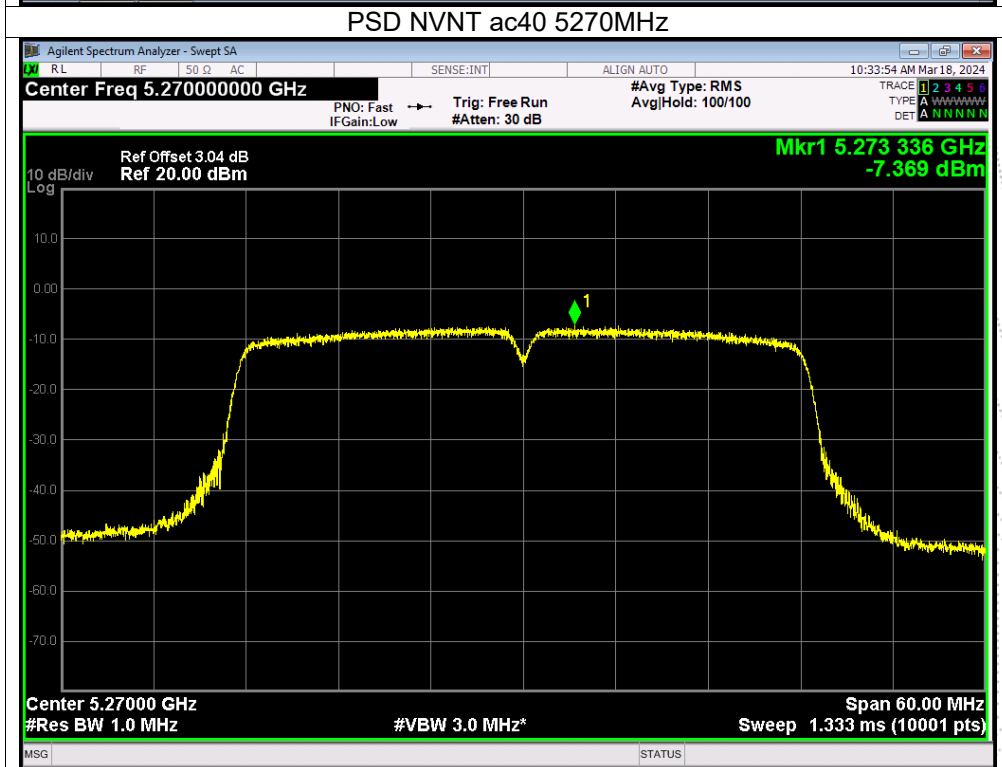
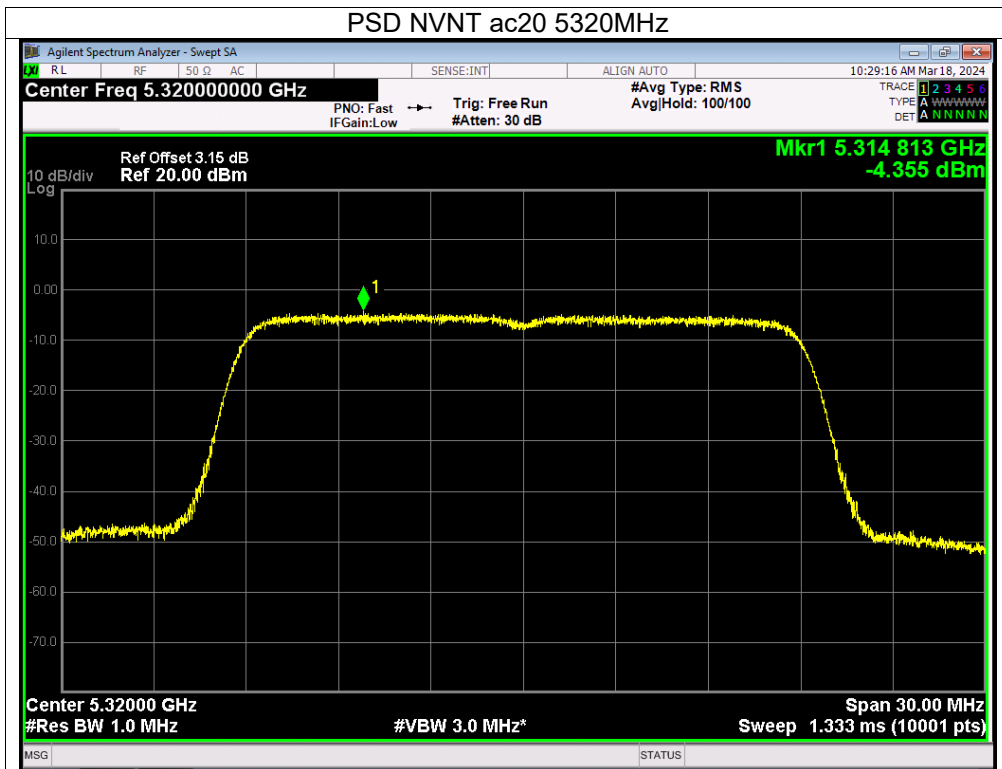

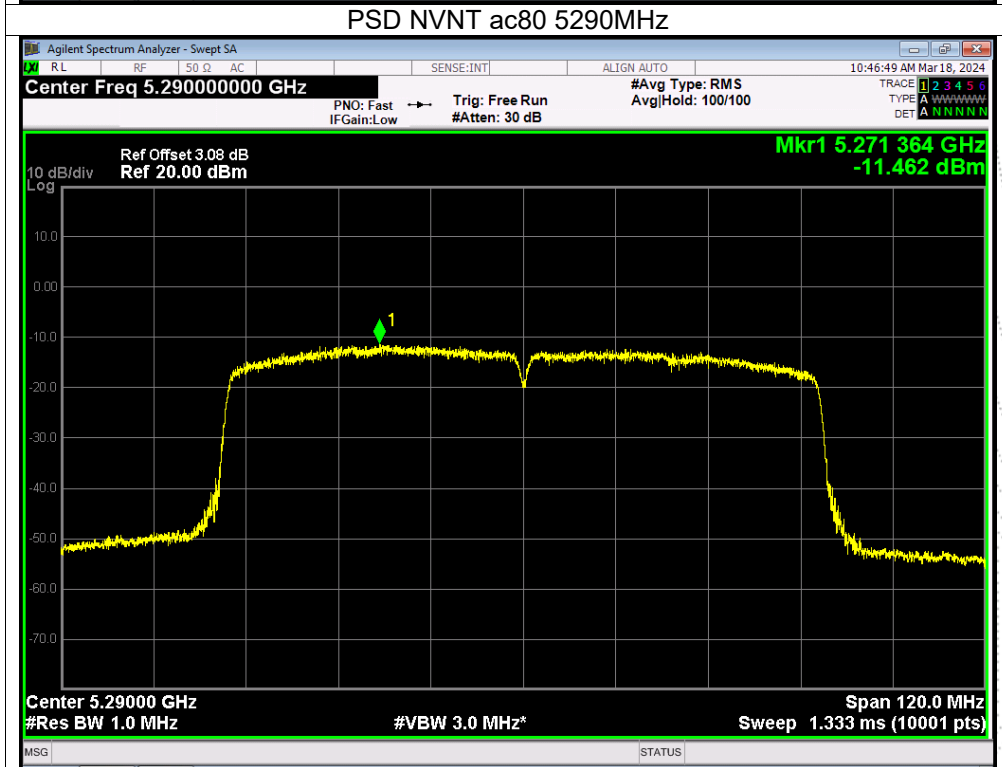
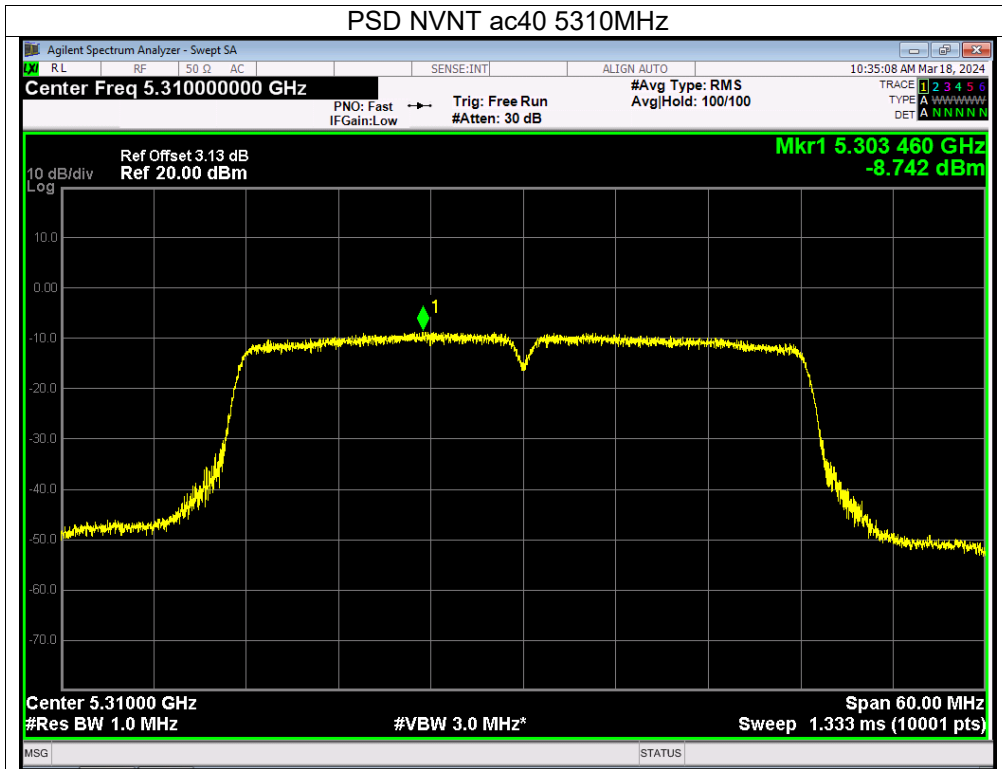



|              |                |                    |              |
|--------------|----------------|--------------------|--------------|
| Temperature: | 26 °C          | Relative Humidity: | 54%          |
| Pressure:    | 101KPa         | Test Voltage:      | AC 120V/60Hz |
| Test Mode:   | (5500-5700MHz) |                    |              |

| Condition | Mode | Frequency (MHz) | Conducted PSD (dBm/MHz) |             | Total (dBm/MHz) | Limit (dBm/MHz) | Verdict |
|-----------|------|-----------------|-------------------------|-------------|-----------------|-----------------|---------|
|           |      |                 | Ant A                   | Ant B       |                 |                 |         |
| NVNT      | a    | 5500            | -3.89                   | -2.97       | /               | 11              | Pass    |
| NVNT      | a    | 5580            | -0.95                   | -0.71       | /               | 11              | Pass    |
| NVNT      | a    | 5700            | -0.27                   | <b>0.54</b> | /               | 11              | Pass    |
| NVNT      | n20  | 5500            | -5.03                   | -4.3        | -1.64           | 11              | Pass    |
| NVNT      | n20  | 5580            | -2.37                   | -1.99       | 0.83            | 11              | Pass    |
| NVNT      | n20  | 5700            | -1.54                   | -1.01       | 1.74            | 11              | Pass    |
| NVNT      | n40  | 5510            | -8.23                   | -7.73       | -4.96           | 11              | Pass    |
| NVNT      | n40  | 5550            | -6.9                    | -6.88       | -3.88           | 11              | Pass    |
| NVNT      | n40  | 5670            | -4.94                   | -4.36       | -1.63           | 11              | Pass    |
| NVNT      | ac20 | 5500            | -5.26                   | -4.5        | -1.85           | 11              | Pass    |
| NVNT      | ac20 | 5580            | -2.5                    | -2.13       | 0.70            | 11              | Pass    |
| NVNT      | ac20 | 5700            | -1.53                   | -1          | 1.75            | 11              | Pass    |
| NVNT      | ac40 | 5510            | -8.15                   | -7.61       | -4.86           | 11              | Pass    |
| NVNT      | ac40 | 5550            | -7.16                   | -6.86       | -4.00           | 11              | Pass    |
| NVNT      | ac40 | 5670            | -5.1                    | -4.1        | -1.56           | 11              | Pass    |
| NVNT      | ac80 | 5530            | -9.99                   | -8.4        | -6.11           | 11              | Pass    |

**Note:**

Antenna A gain: 2.55 dBi, Antenna B gain: 2.55 dBi, Directional gain=[ GainANT + 10 log(NANT/NSS) dBi]  
 =5.56 dBi<6dBi

Limit=11 dBi

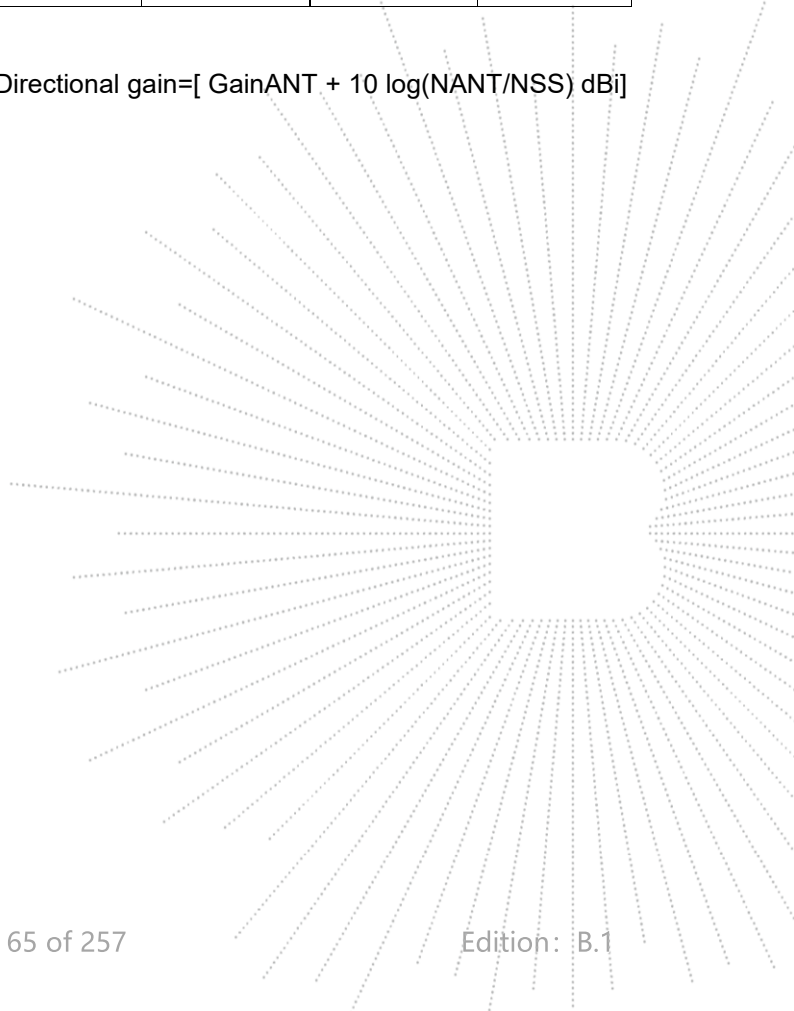

Note: A(B) Represent the value of antenna A and B, The worst data is Antenna B, only shown Antenna B Plot. Note:

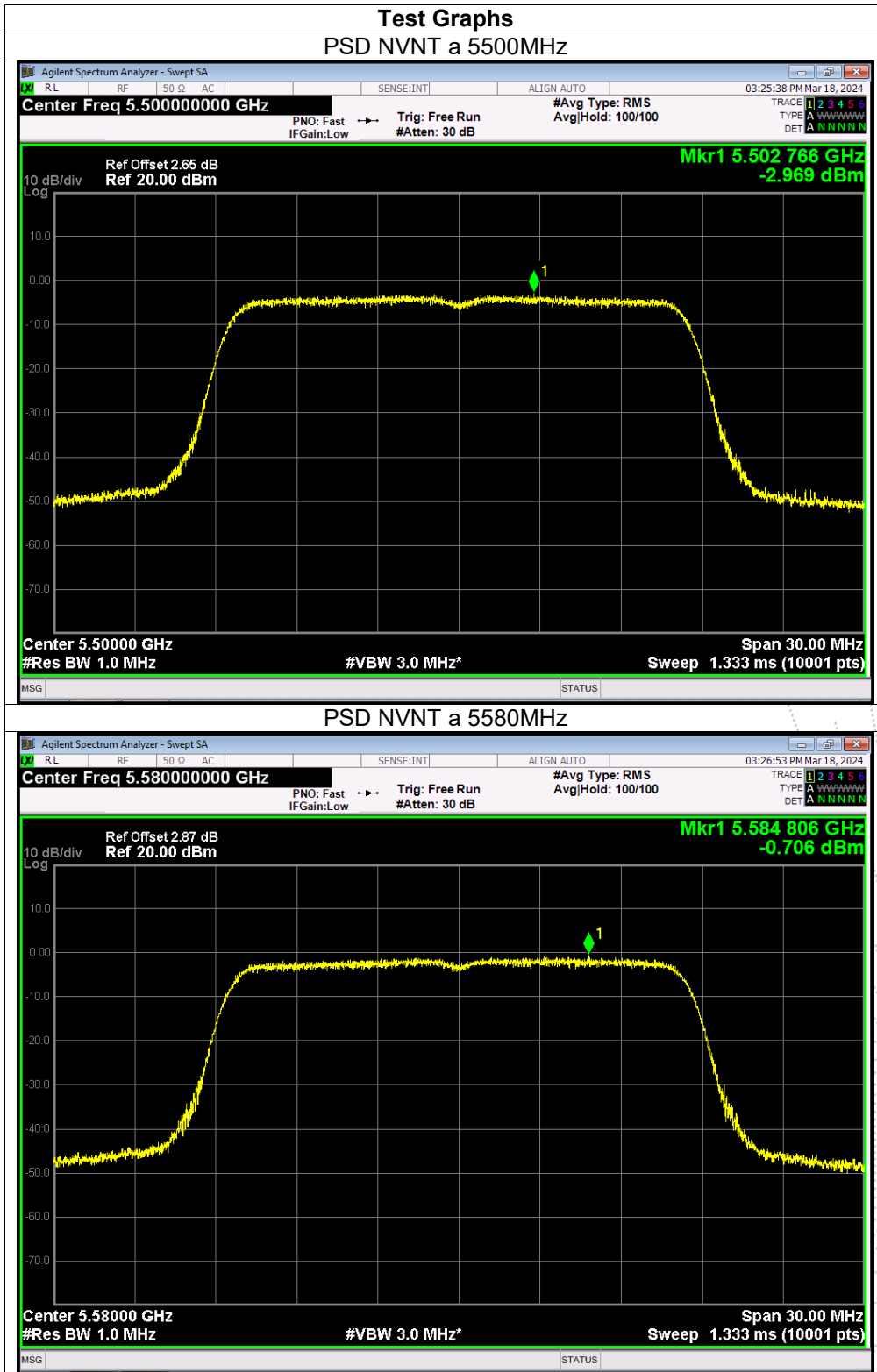

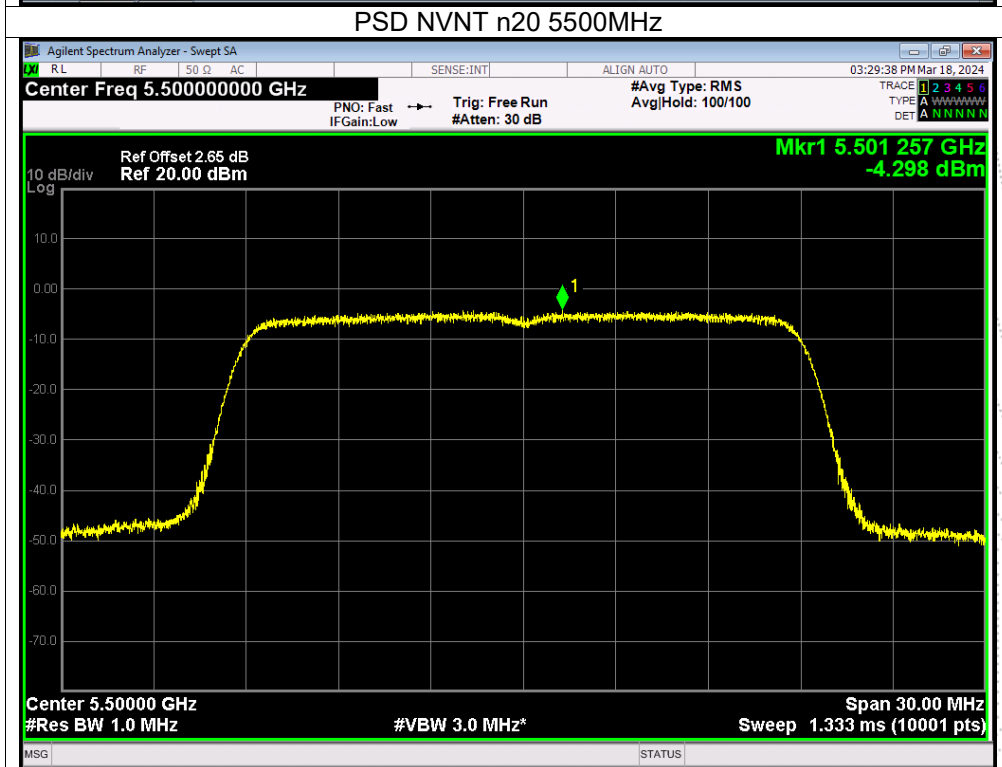
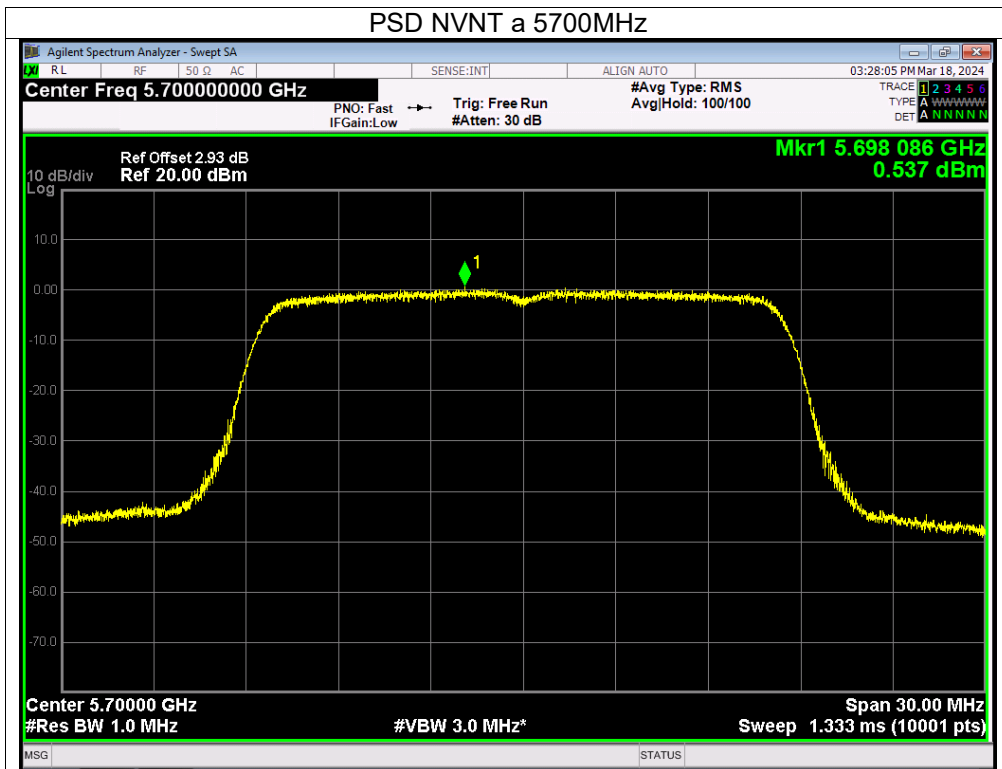

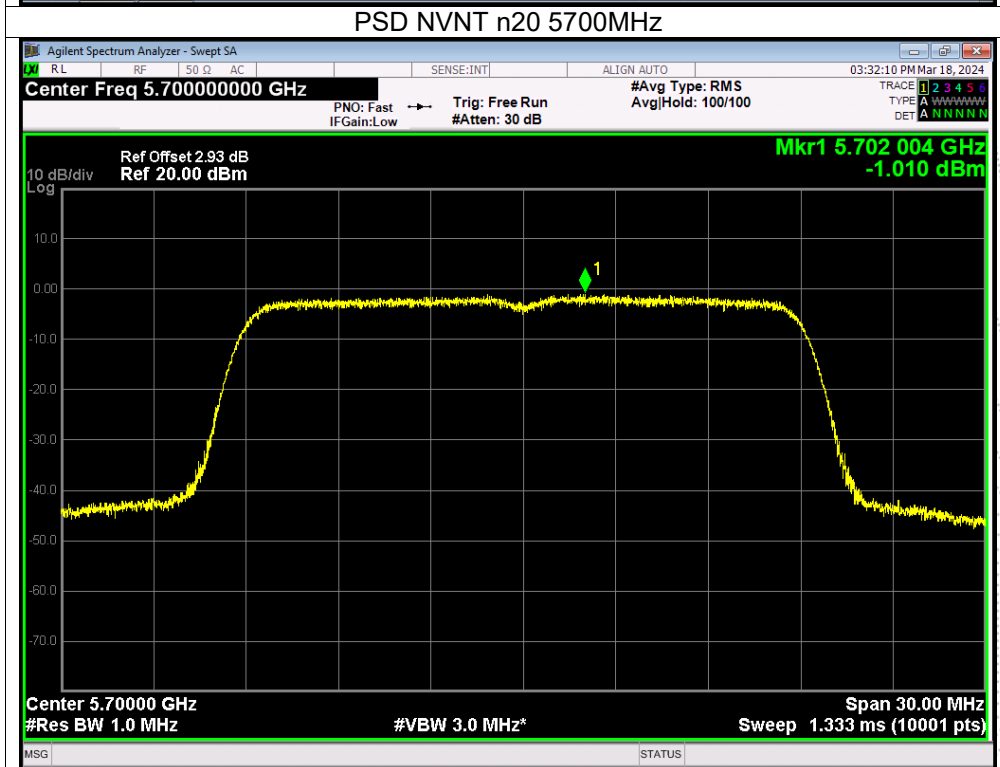
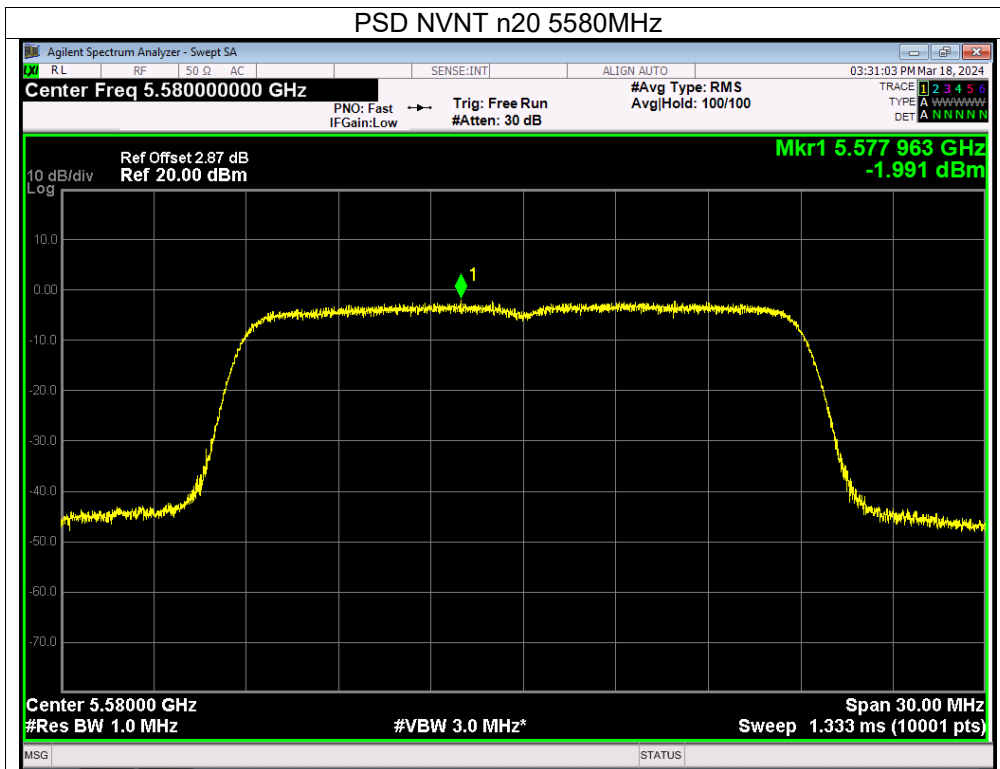

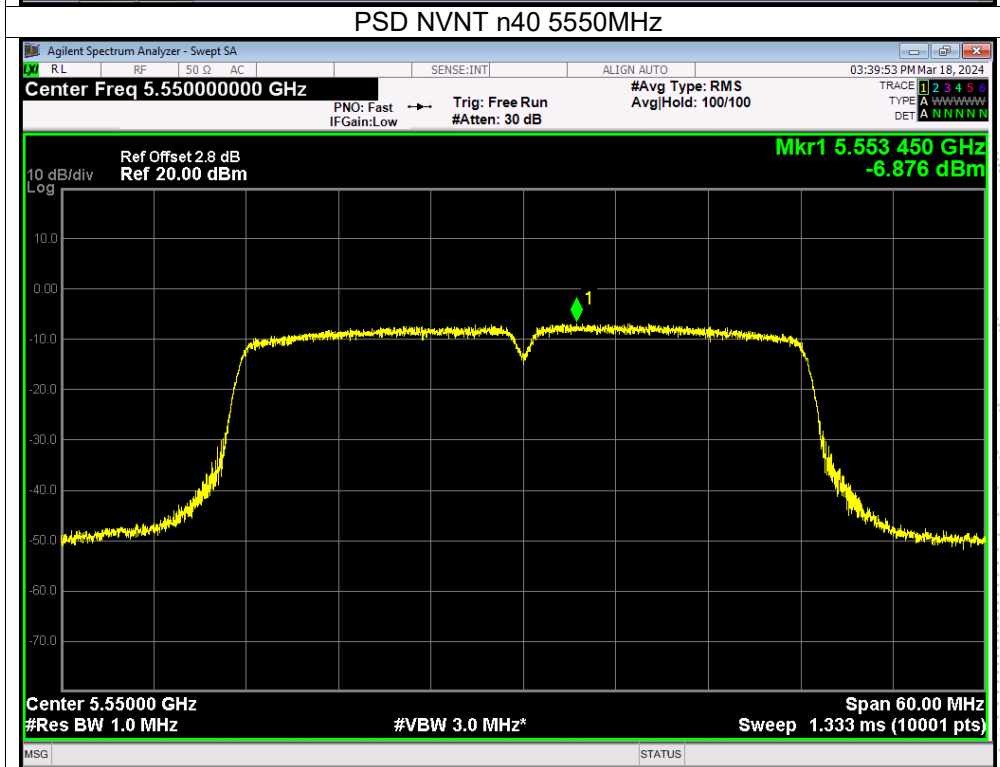
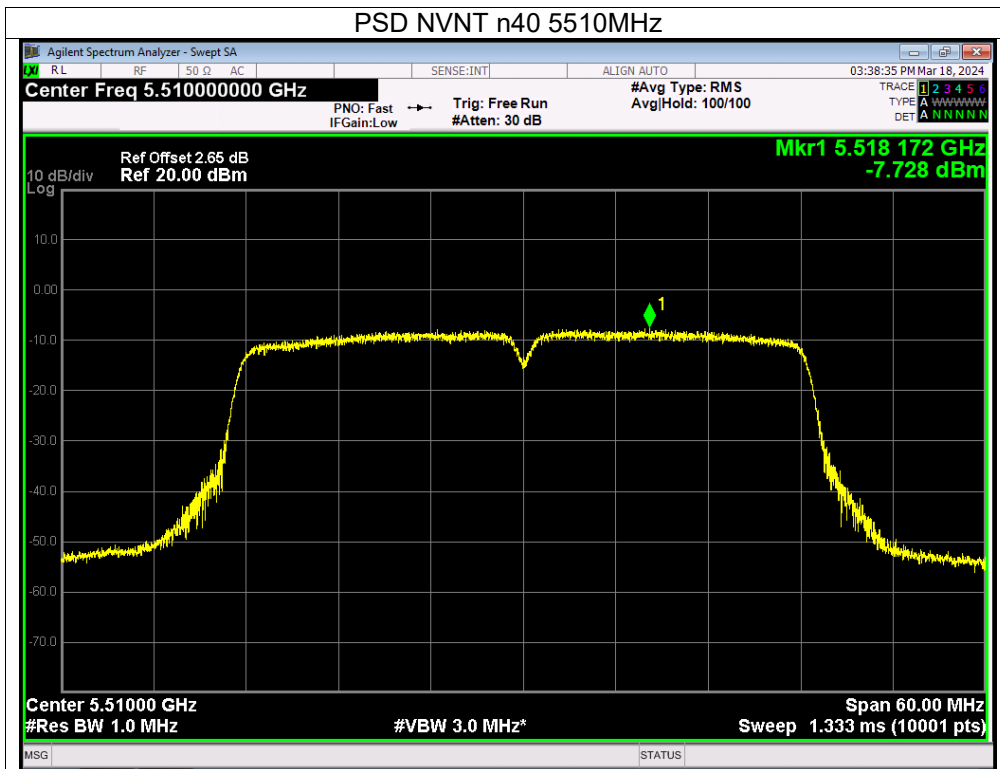

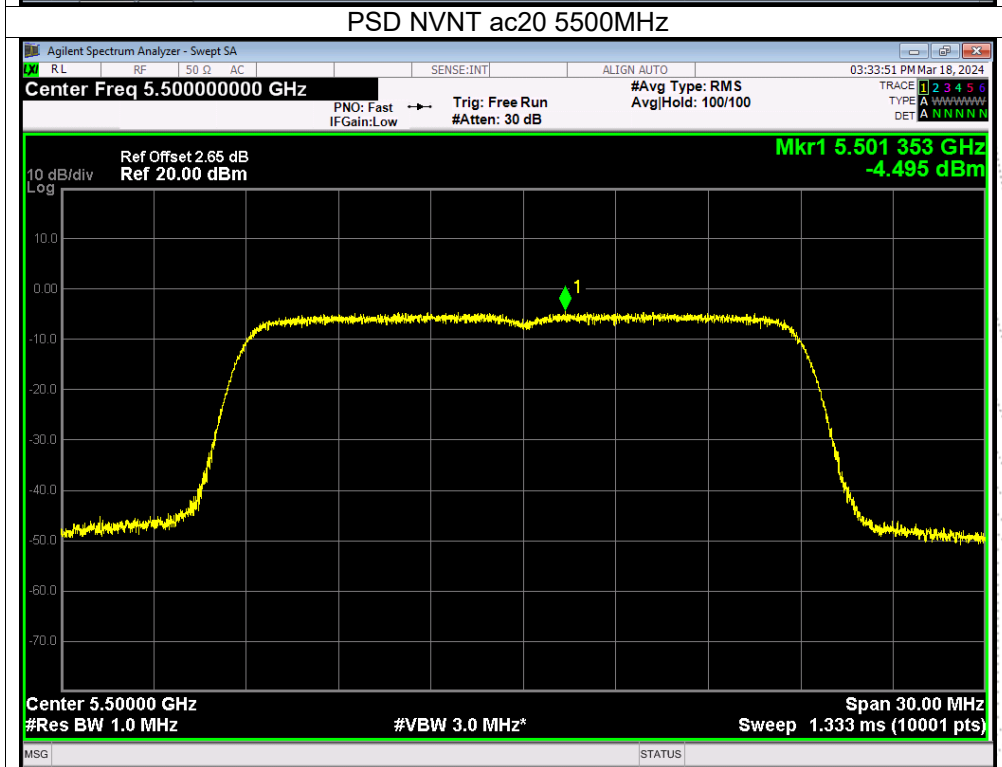
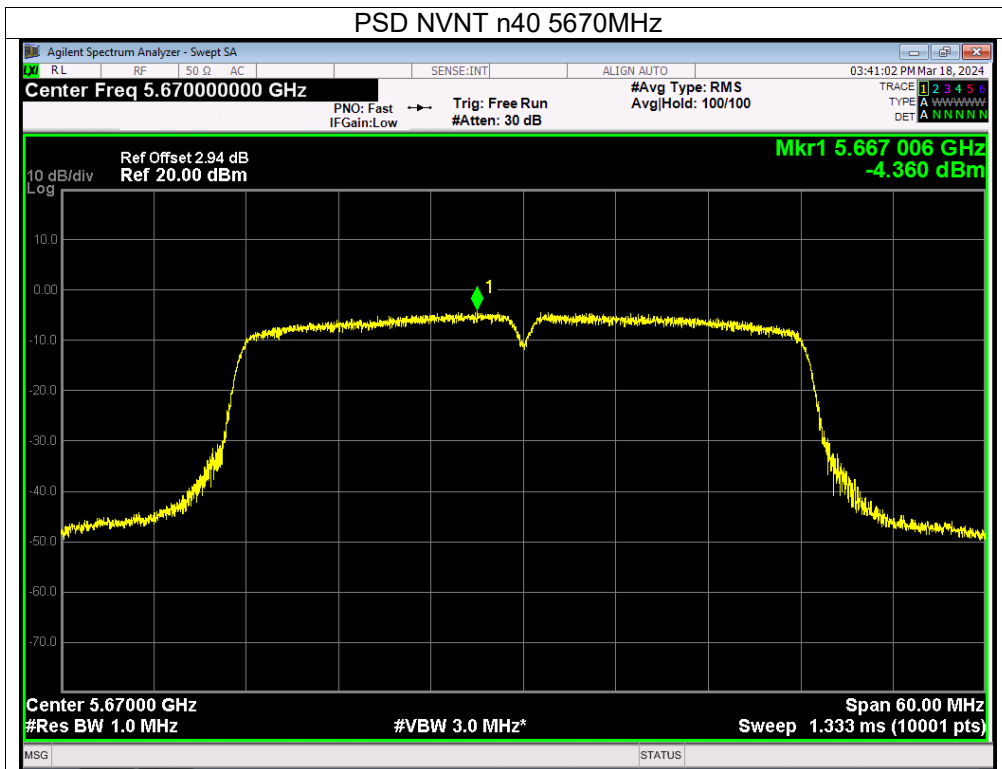

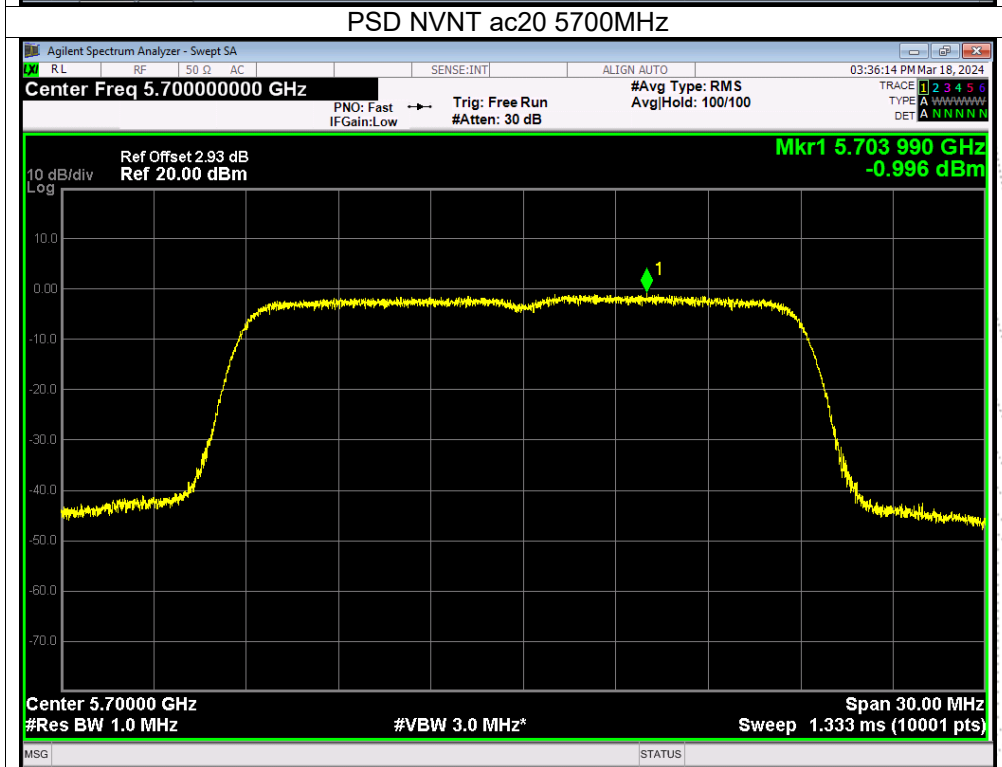
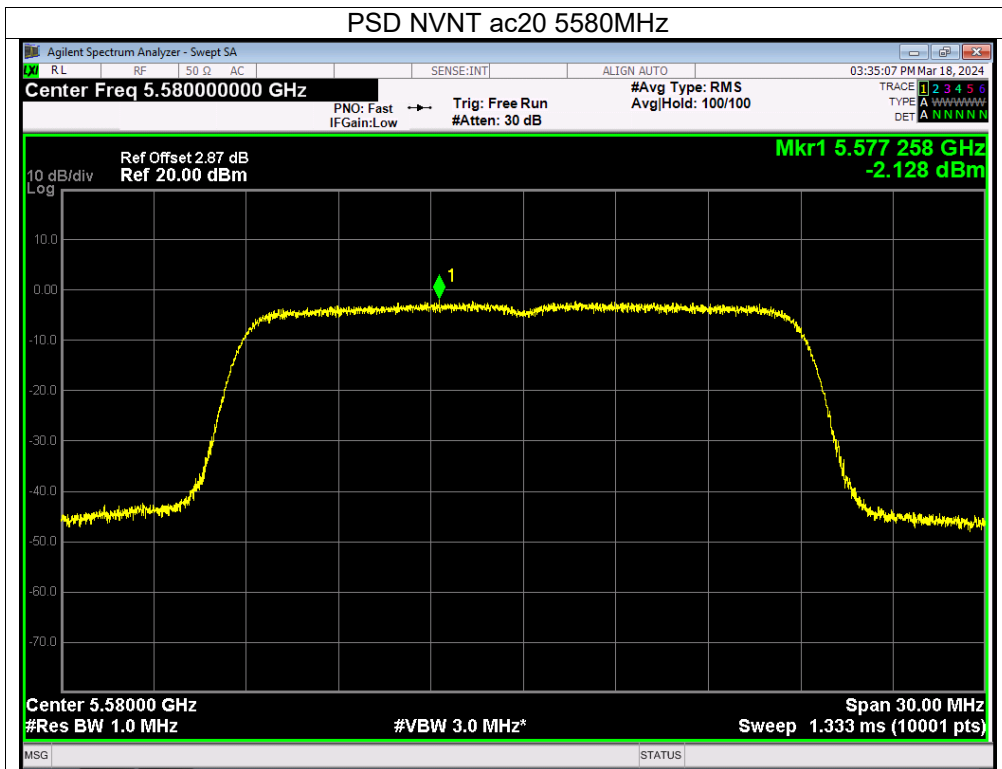

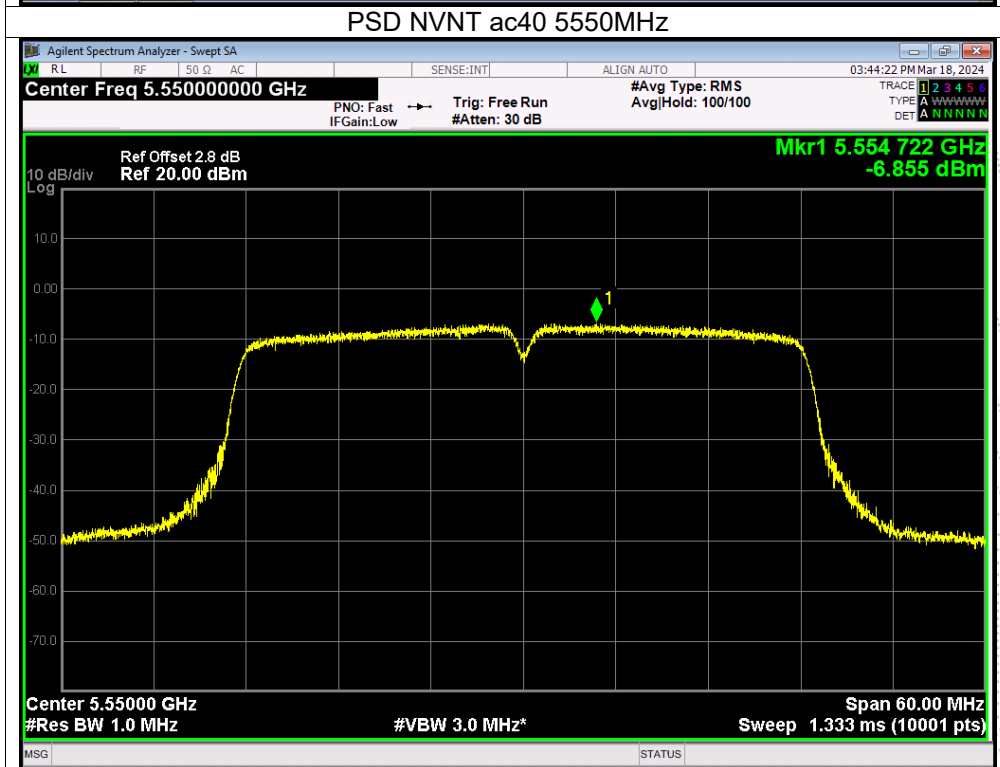
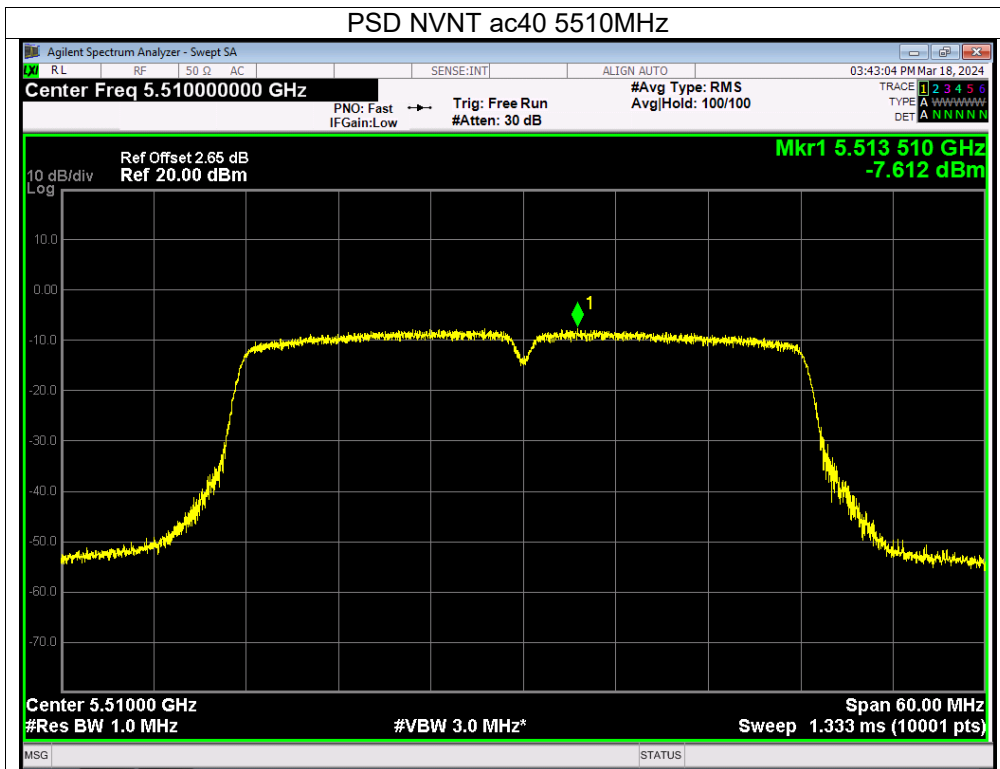



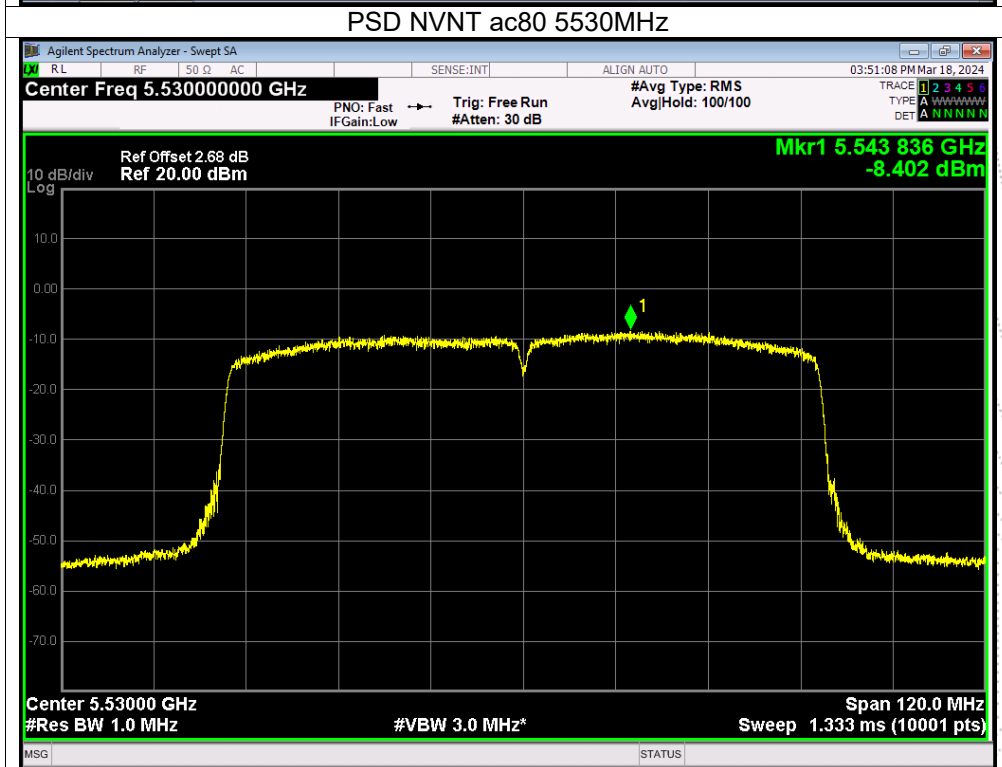
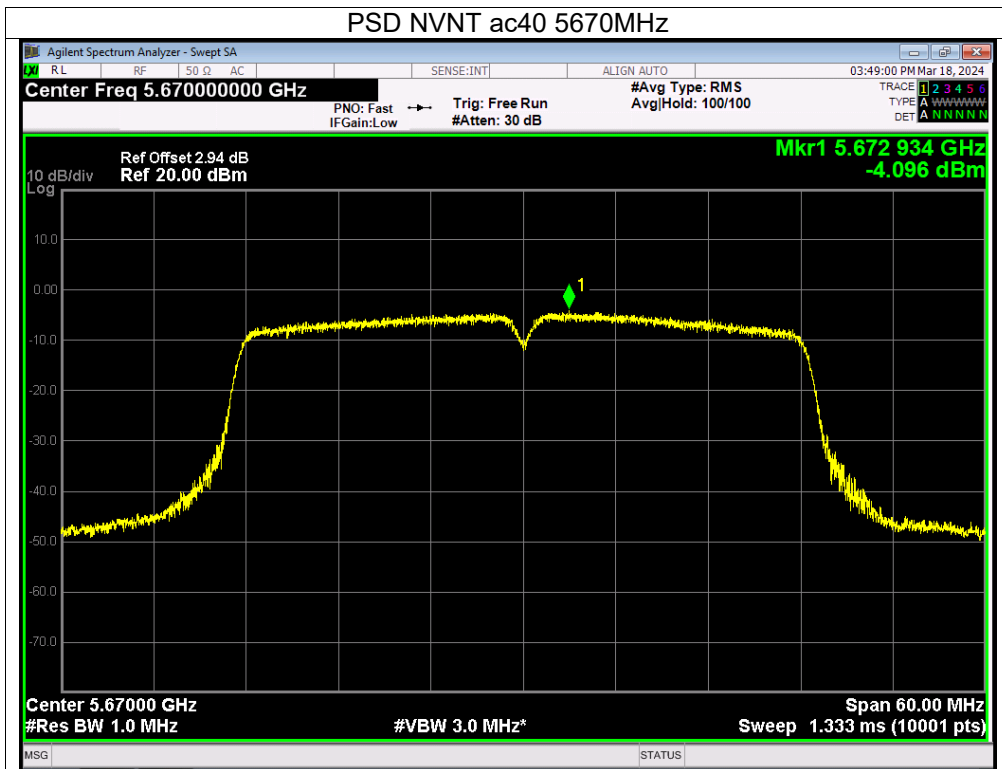

|              |                |                    |              |
|--------------|----------------|--------------------|--------------|
| Temperature: | 26 °C          | Relative Humidity: | 54%          |
| Pressure:    | 101KPa         | Test Voltage:      | AC 120V/60Hz |
| Test Mode:   | (5745-5825MHz) |                    |              |

| Condition | Mode | Fre-<br>quency<br>(MHz) | Conducted PSD<br>(dBm/510KHz) |              | Conducted<br>PSD<br>(dBm/500KHz) |         | Total<br>(dBm/<br>500KHz) | Limit<br>(dBm/<br>500KHz) | Verdict |
|-----------|------|-------------------------|-------------------------------|--------------|----------------------------------|---------|---------------------------|---------------------------|---------|
|           |      |                         | Ant A                         | Ant B        | Ant A                            | Ant B   |                           |                           |         |
| NVNT      | a    | 5745                    | -3.31                         | <b>-3.02</b> | -3.396                           | -3.106  | /                         | 30                        | Pass    |
| NVNT      | a    | 5785                    | -3.61                         | -3.72        | -3.696                           | -3.806  | /                         | 30                        | Pass    |
| NVNT      | a    | 5825                    | -4.19                         | -3.96        | -4.276                           | -4.046  | /                         | 30                        | Pass    |
| NVNT      | n20  | 5745                    | -5.19                         | -5.09        | -5.276                           | -5.176  | -2.22                     | 30                        | Pass    |
| NVNT      | n20  | 5785                    | -5.06                         | -5.39        | -5.146                           | -5.476  | -2.30                     | 30                        | Pass    |
| NVNT      | n20  | 5825                    | -6                            | -5.66        | -6.086                           | -5.746  | -2.90                     | 30                        | Pass    |
| NVNT      | n40  | 5755                    | -9.22                         | -9.18        | -9.306                           | -9.266  | -6.28                     | 30                        | Pass    |
| NVNT      | n40  | 5795                    | -9.86                         | -9.28        | -9.946                           | -9.366  | -6.64                     | 30                        | Pass    |
| NVNT      | ac20 | 5745                    | -5.19                         | -5.28        | -5.276                           | -5.366  | -2.31                     | 30                        | Pass    |
| NVNT      | ac20 | 5785                    | -5.27                         | -5.31        | -5.356                           | -5.396  | -2.37                     | 30                        | Pass    |
| NVNT      | ac20 | 5825                    | -6.19                         | -5.8         | -6.276                           | -5.886  | -3.07                     | 30                        | Pass    |
| NVNT      | ac40 | 5755                    | -9.15                         | -9.3         | -9.236                           | -9.386  | -6.30                     | 30                        | Pass    |
| NVNT      | ac40 | 5795                    | -9.56                         | -9.49        | -9.646                           | -9.576  | -6.60                     | 30                        | Pass    |
| NVNT      | ac80 | 5775                    | -13.12                        | -12.54       | -13.206                          | -12.626 | -9.90                     | 30                        | Pass    |

Note: Correction Factor =  $10\log(500\text{KHz}/\text{RBW in measurement}) = -0.086$

**Note:**

Antenna A gain: 2.55 dBi, Antenna B gain: 2.55 dBi, Directional gain = [GainANT + 10 log(NANT/NSS) dBi]  
 = 5.56 dBi < 6 dBi  
 EIRP Limit = 30 dBi

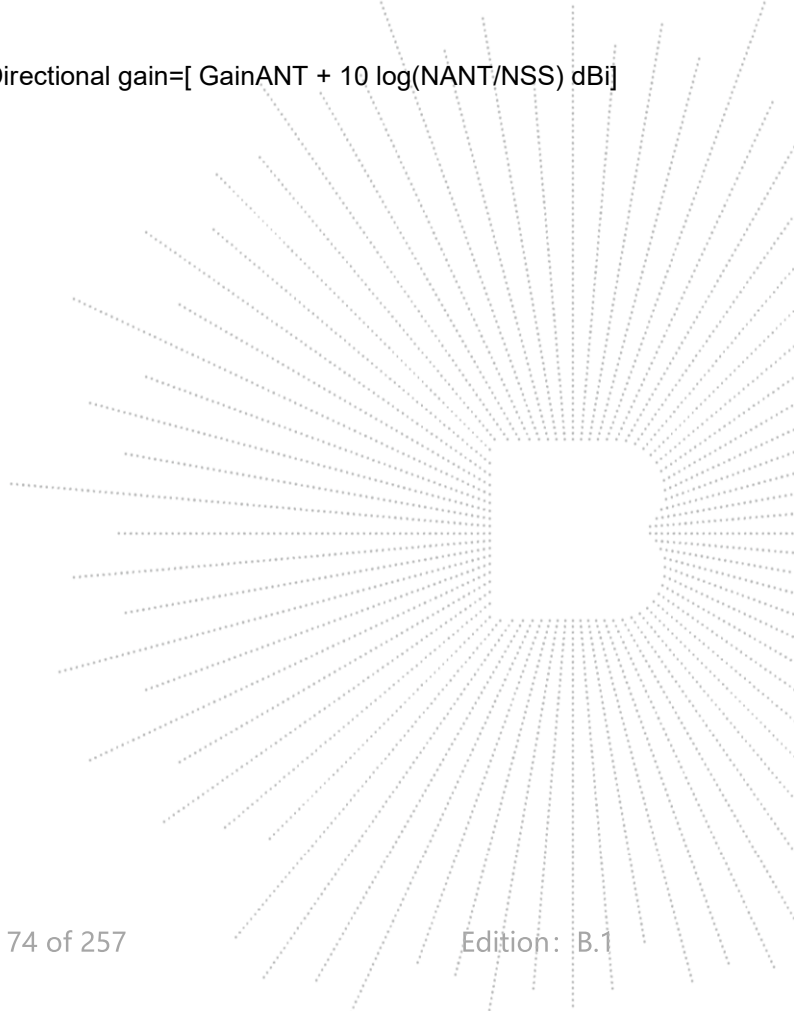

Note: A(B) Represent the value of antenna A and B, The worst data is Antenna B, only shown Antenna B Plot.

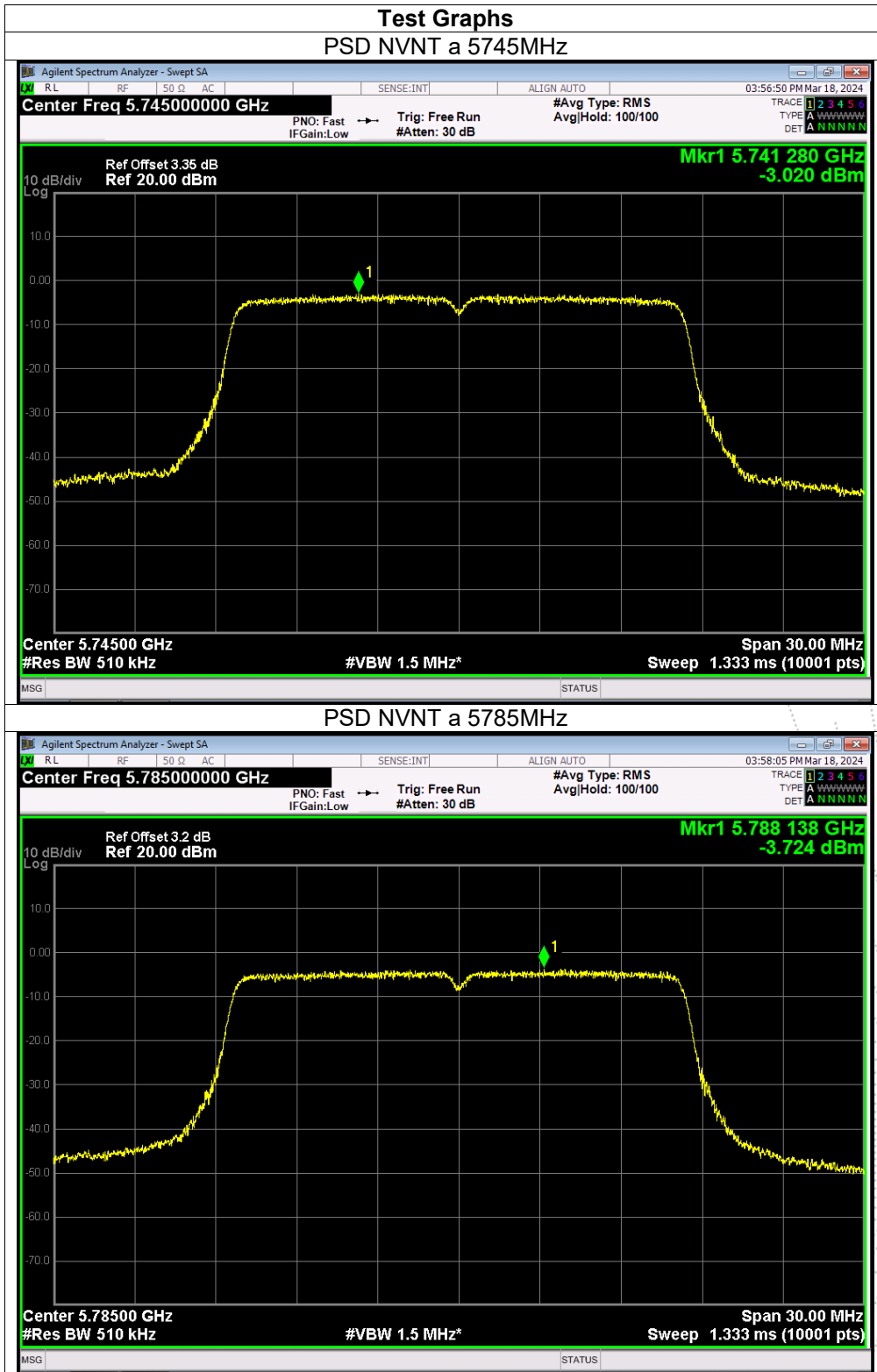

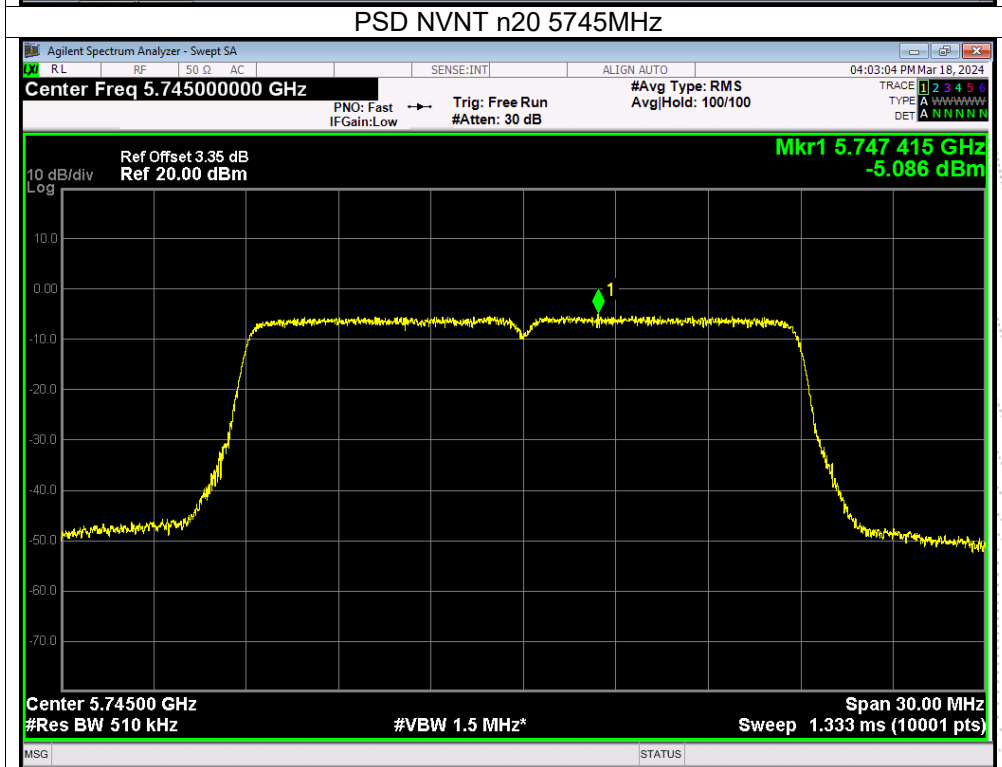
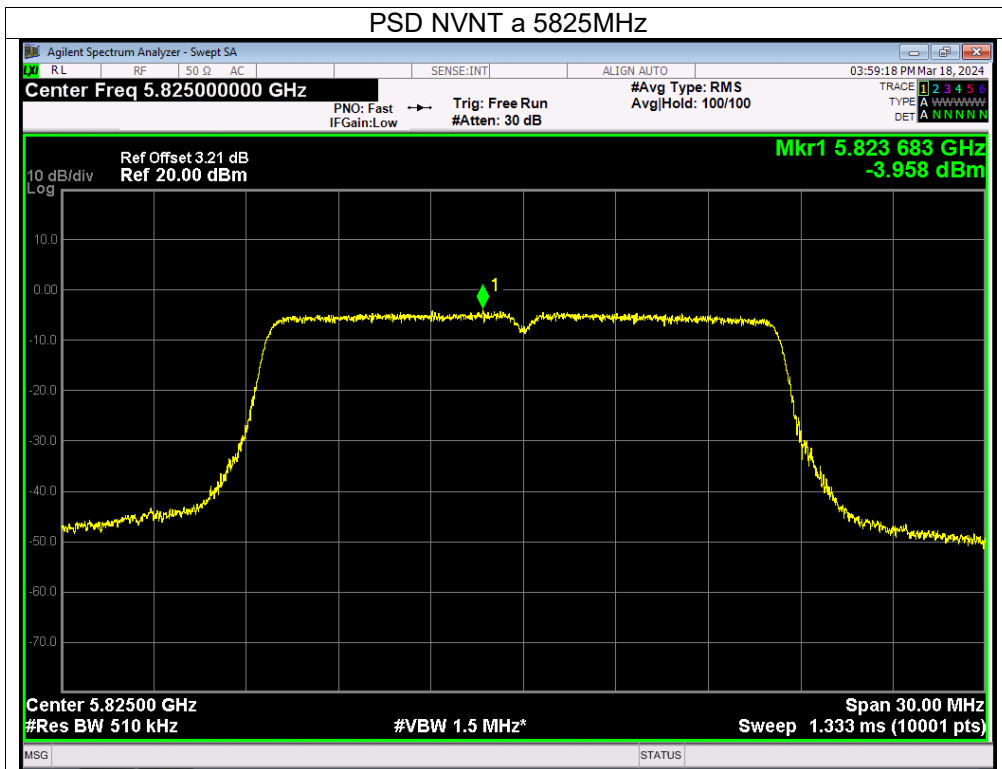

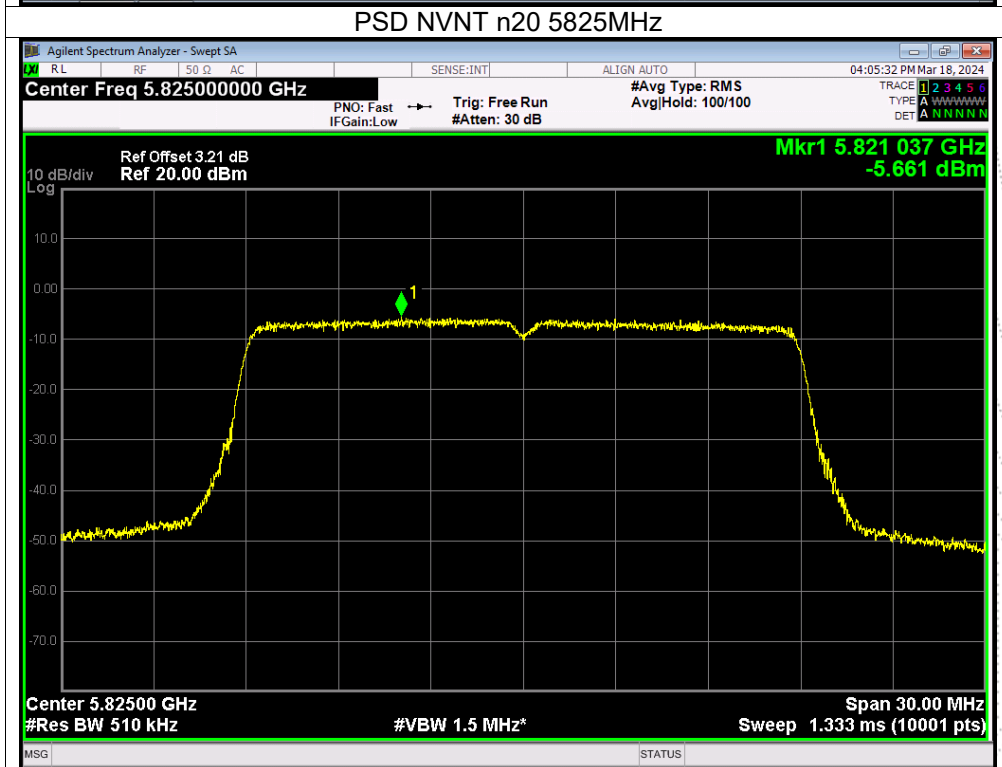
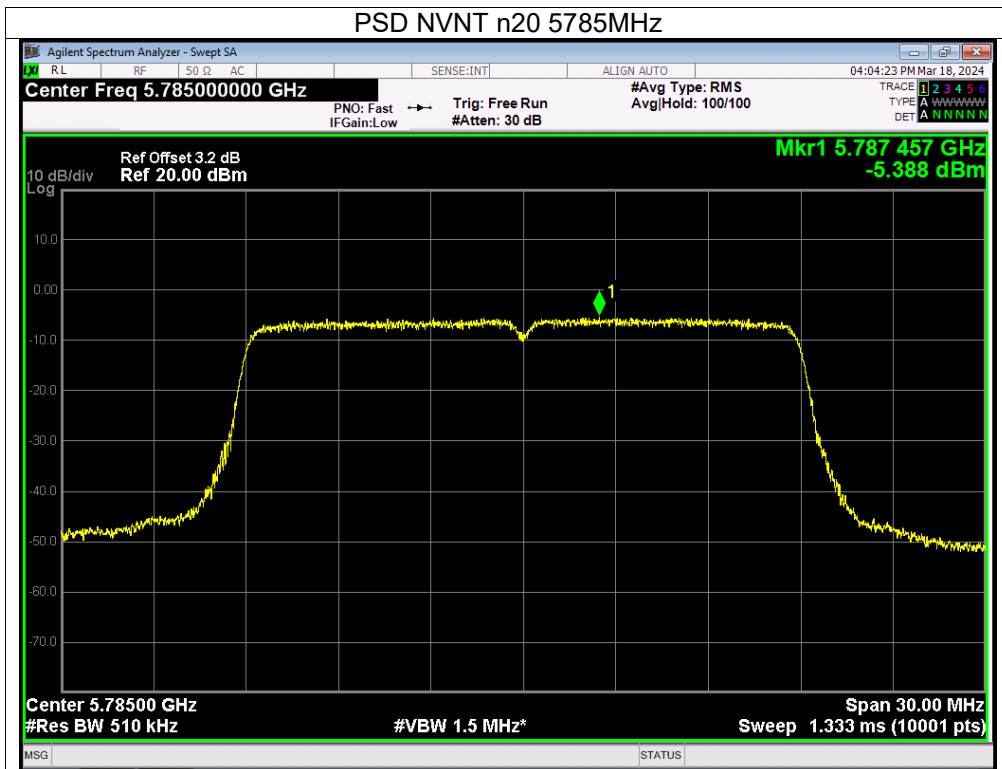

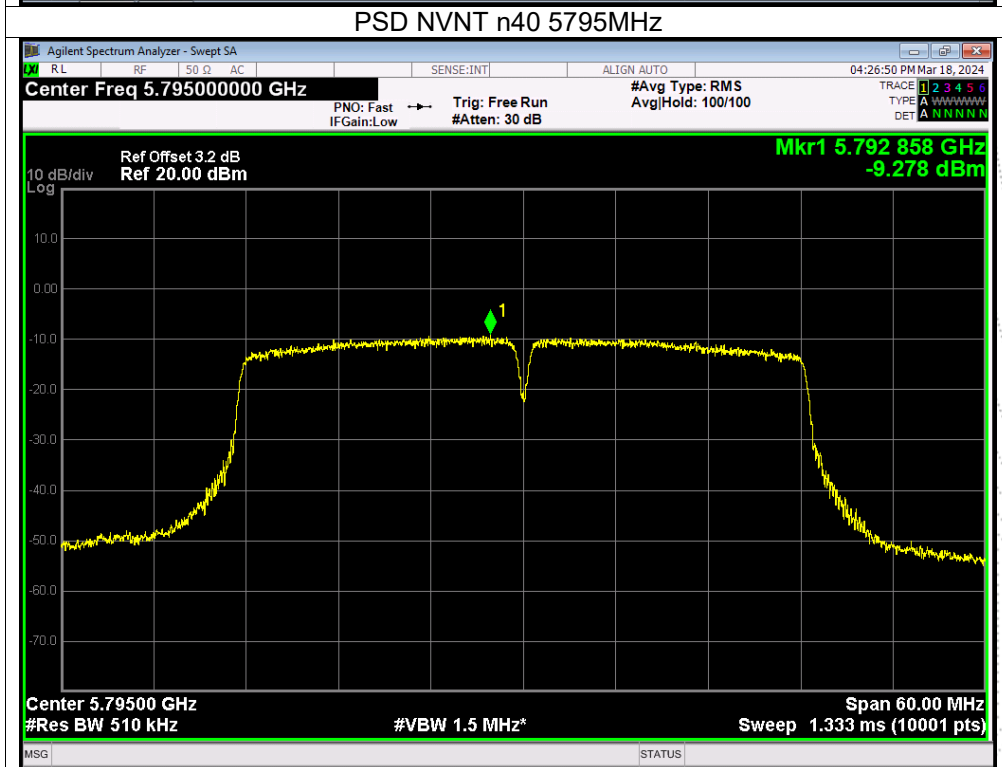
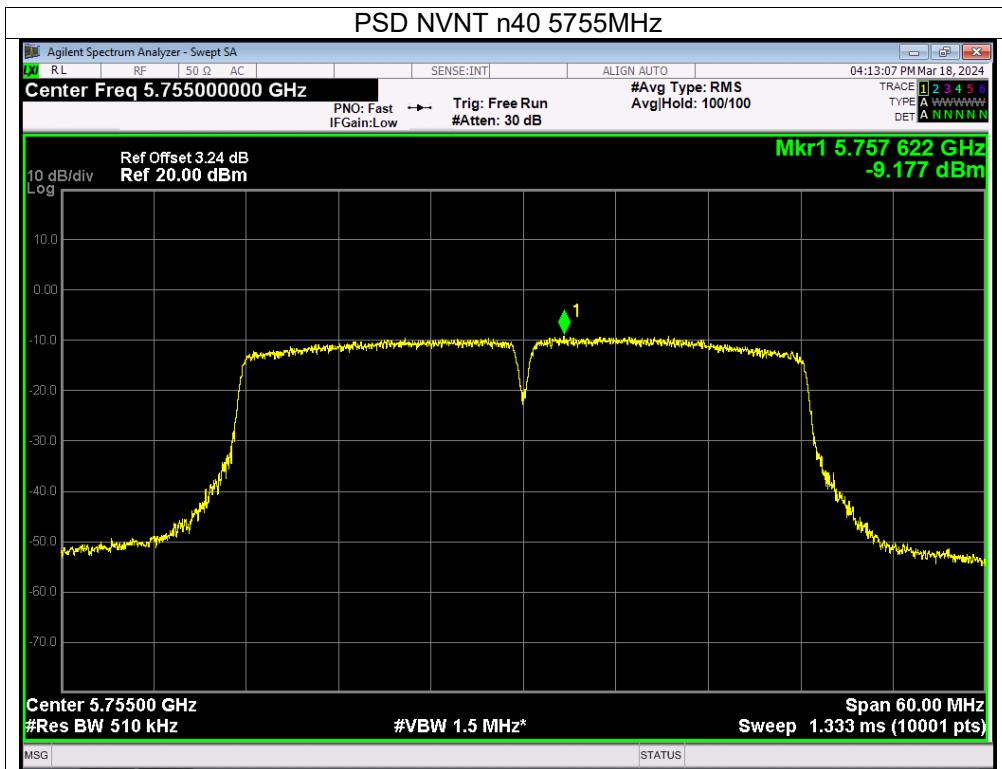

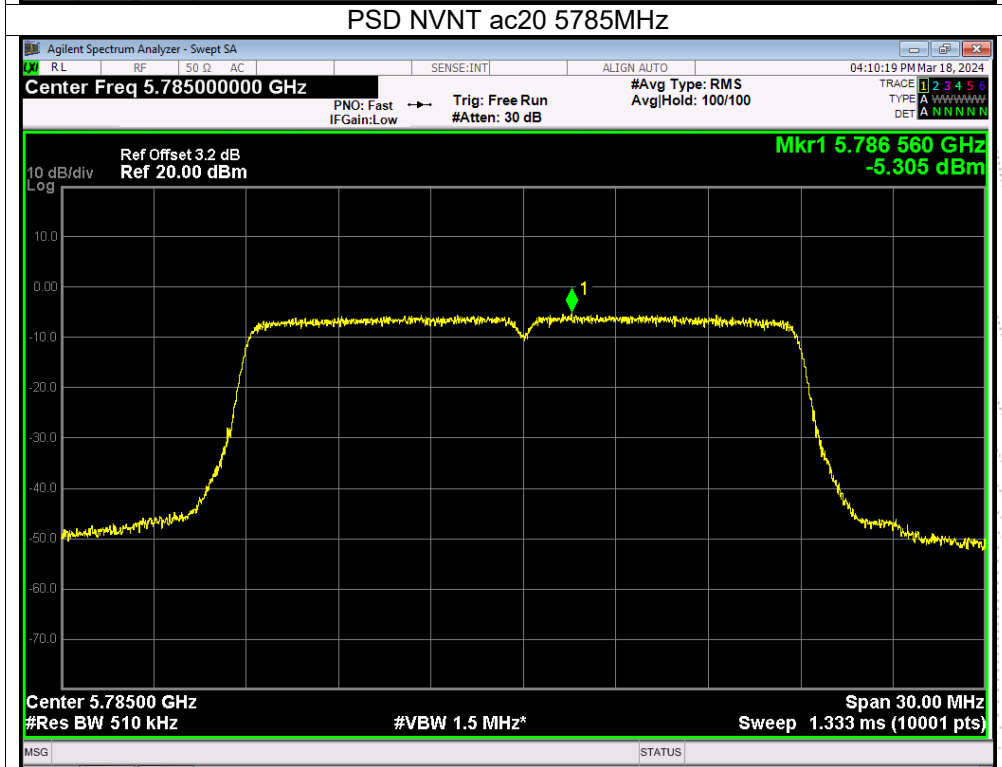
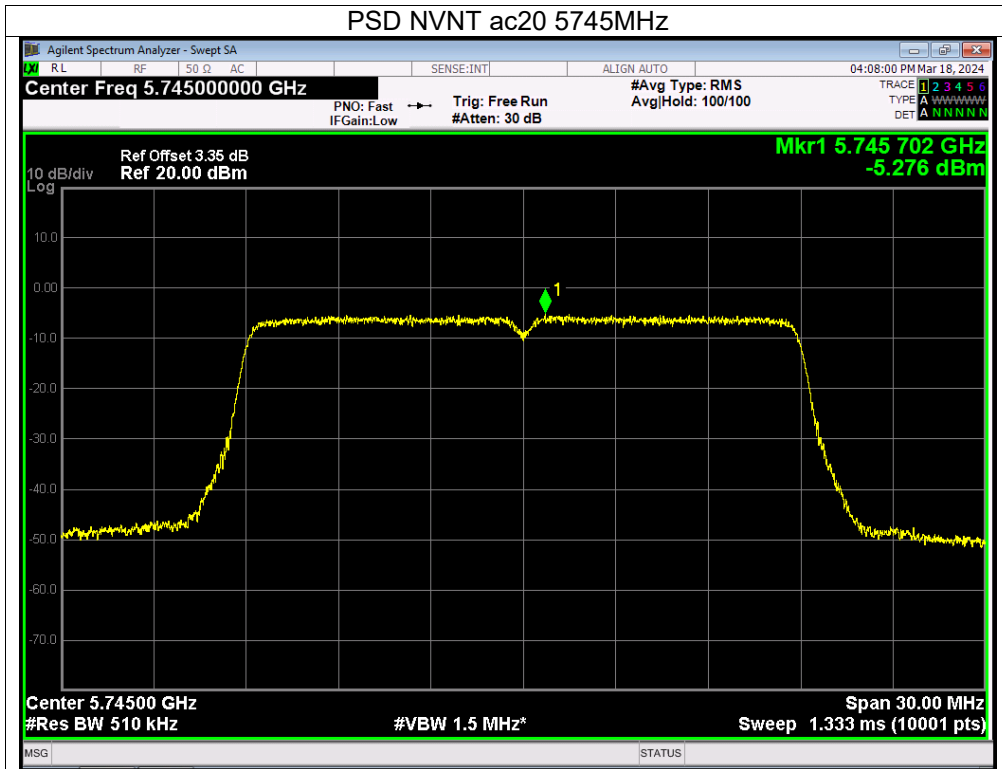

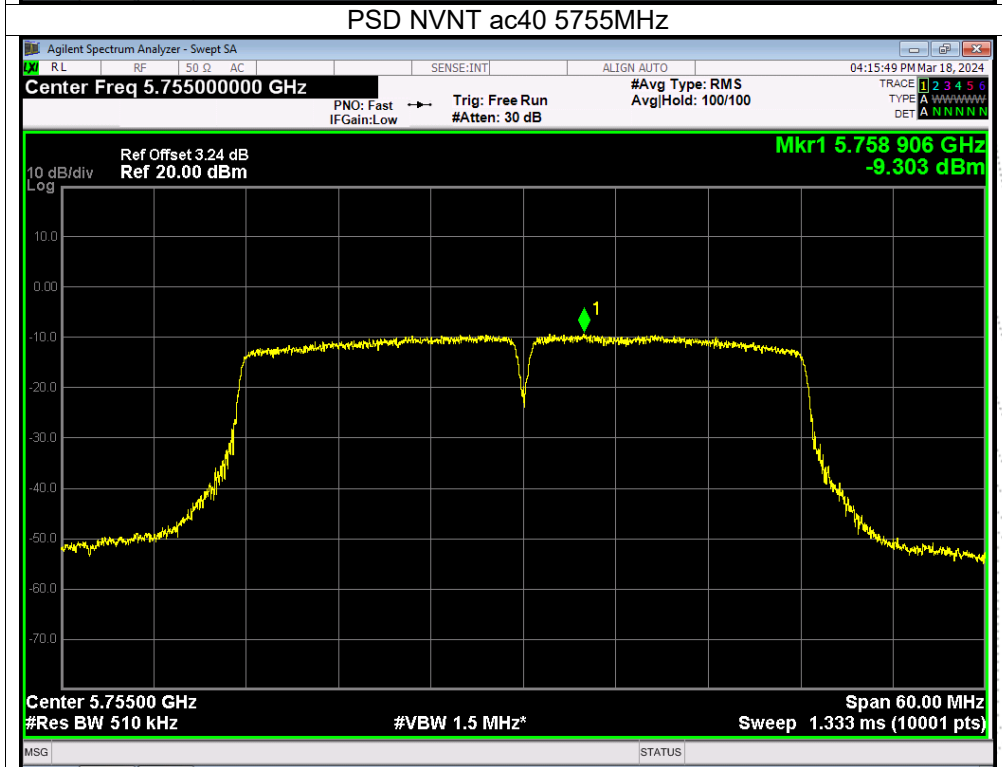
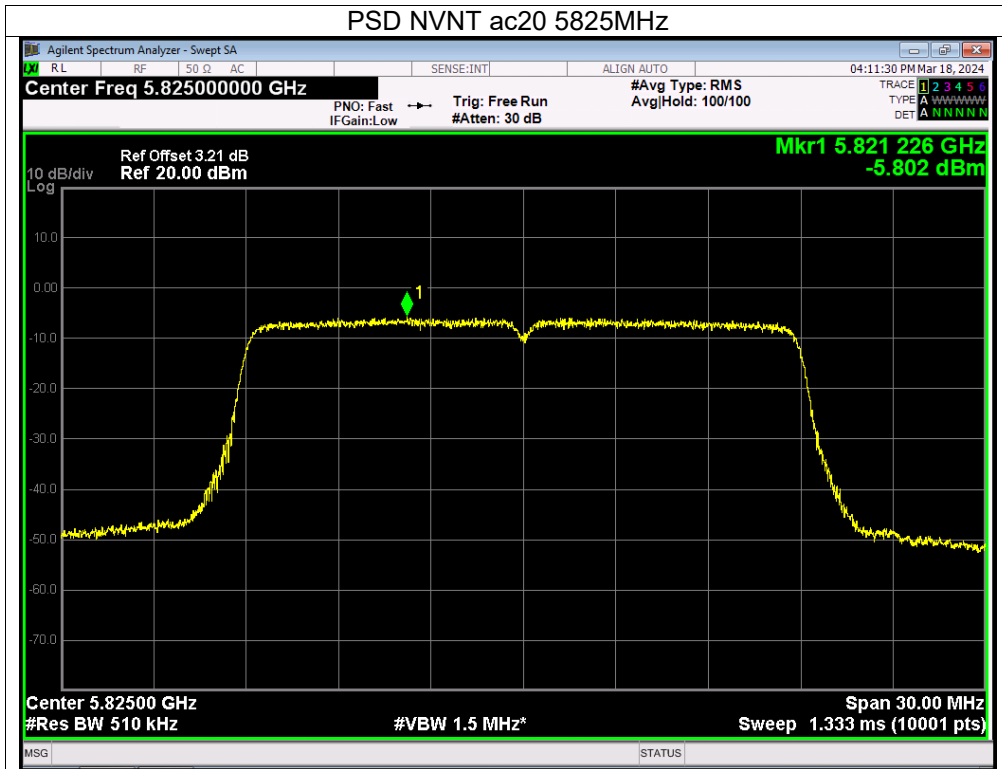



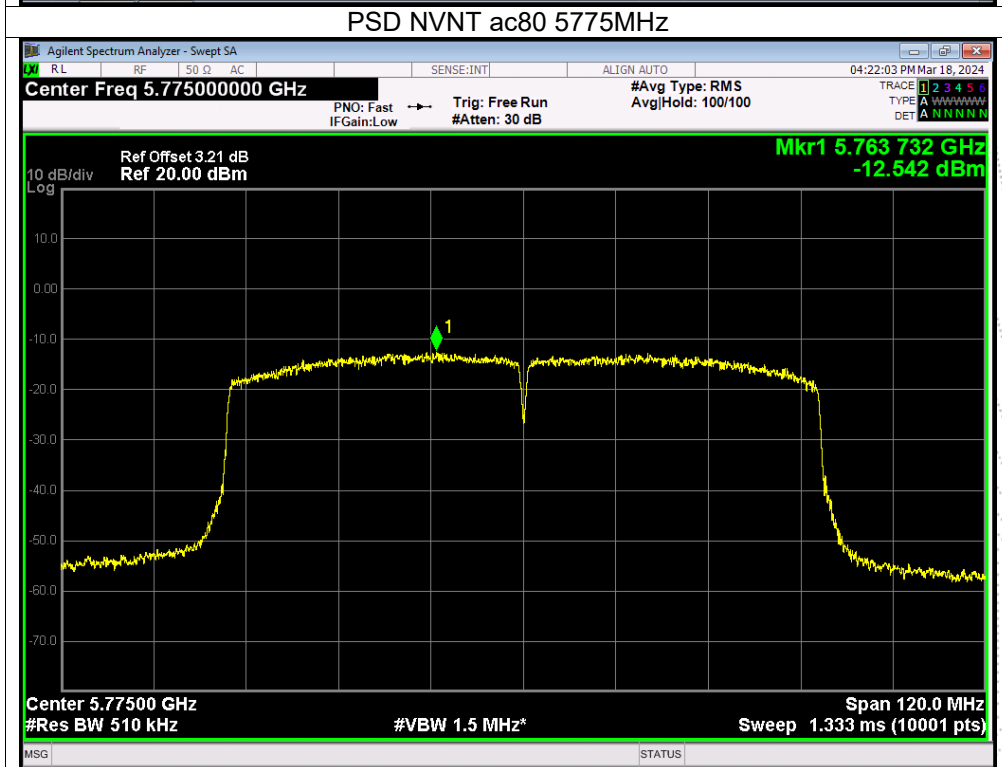
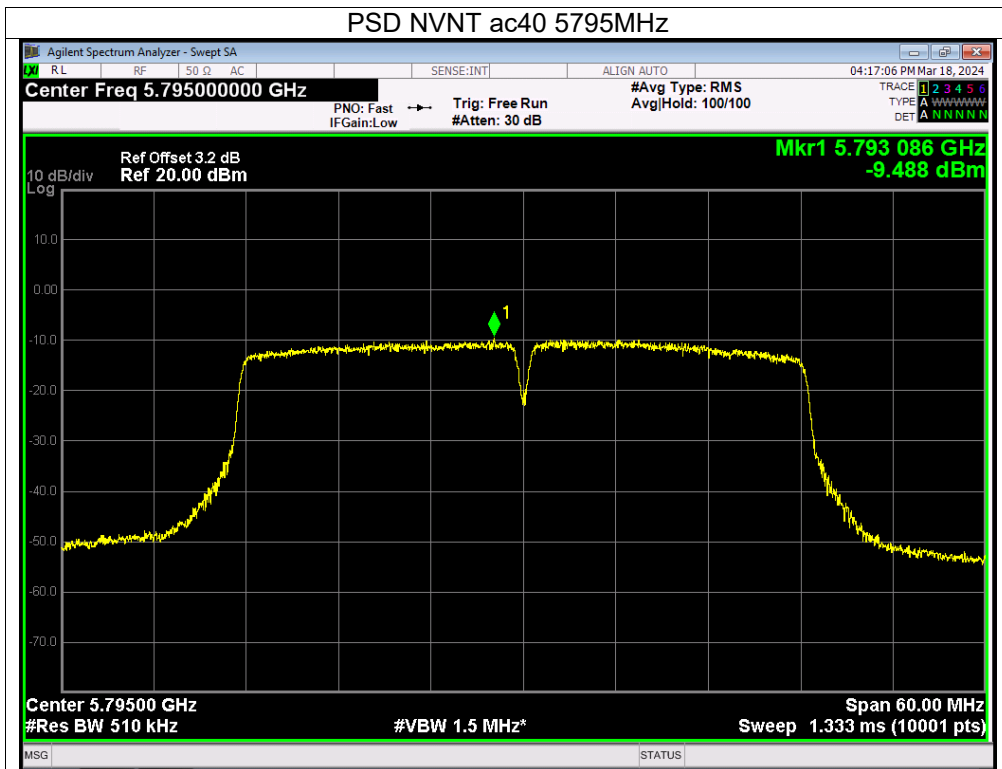

## 9. 26dB & 6dB & 99% Emission Bandwidth

### 9.1 Block Diagram Of Test Setup

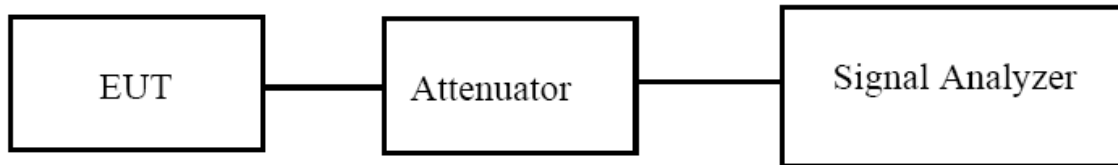

### 9.2 Limit

(1) For the band 5.15-5.25 GHz.

(iv) For mobile and portable client devices in the 5.15-5.25 GHz band, the maximum conducted output power over the frequency band of operation shall not exceed 250 mW provided the maximum antenna gain does not exceed 6 dBi. In addition, the maximum power spectral density shall not exceed 11 dBm in any 1 megahertz band. If transmitting antennas of directional gain greater than 6 dBi are used, both the maximum conducted output power and the maximum power spectral density shall be reduced by the amount in dB that the directional gain of the antenna exceeds 6 dBi.

(2) For the 5.25-5.35 GHz and 5.47-5.725 GHz bands, the maximum conducted output power over the frequency bands of operation shall not exceed the lesser of 250 mW or  $11 \text{ dBm} + 10 \log B$ , where B is the 26 dB emission bandwidth in megahertz. In addition, the maximum power spectral density shall not exceed 11 dBm in any 1 megahertz band. If transmitting antennas of directional gain greater than 6 dBi are used, both the maximum conducted output power and the maximum power spectral density shall be reduced by the amount in dB that the directional gain of the antenna exceeds 6 dBi.

(3) For the band 5.725-5.85 GHz, the maximum conducted output power over the frequency band of operation shall not exceed 1 W. In addition, the maximum power spectral density shall not exceed 30 dBm in any 500-kHz band. If transmitting antennas of directional gain greater than 6 dBi are used, both the maximum conducted output power and the maximum power spectral density shall be reduced by the amount in dB that the directional gain of the antenna exceeds 6 dBi. However, fixed point-to-point U-NII devices operating in this band may employ transmitting antennas with directional gain greater than 6 dBi without any corresponding reduction in transmitter conducted power. Fixed, point-to-point operations exclude the use of point-to-multipoint systems, omnidirectional applications, and multiple collocated transmitters transmitting the same information. The operator of the U-NII device, or if the equipment is professionally installed, the installer, is responsible for ensuring that systems employing high gain directional antennas are used exclusively for fixed, point-to-point operations.

### 9.3 Test Procedure

- Set RBW = approximately 1% of the emission bandwidth.
- Set the VBW > RBW.
- Detector = Peak.
- Trace mode = max hold.
- Measure the maximum width of the emission that is 26 dB down from the maximum of the emission. Compare this with the RBW setting of the analyzer. Readjust RBW and repeat measurement as needed until the RBW/EBW ratio is approximately 1%.

The following procedure shall be used for measuring (99 %) power bandwidth:

- Set center frequency to the nominal EUT channel center frequency.
- Set span = 1.5 times to 5.0 times the OBW.

3. Set RBW = 1 % to 5 % of the OBW
4. Set VBW  $\geq 3 \cdot$  RBW
5. Video averaging is not permitted. Where practical, a sample detection and single sweep mode shall be used. Otherwise, peak detection and max hold mode (until the trace stabilizes) shall be used.
6. Use the 99 % power bandwidth function of the instrument (if available).
7. If the instrument does not have a 99 % power bandwidth function, the trace data points are recovered and directly summed in power units. The recovered amplitude data points, beginning at the lowest frequency, are placed in a running sum until 0.5 % of the total is reached; that frequency is recorded as the lower frequency. The process is repeated until 99.5 % of the total is reached; that frequency is recorded as the upper frequency. The 99% occupied bandwidth is the difference between these two frequencies.

#### 9.4 EUT Operating Conditions

The EUT was configured for testing in a typical fashion (as a customer would normally use it). The EUT has been programmed to continuously transmit during test. This operating condition was tested and used to collect the included data.

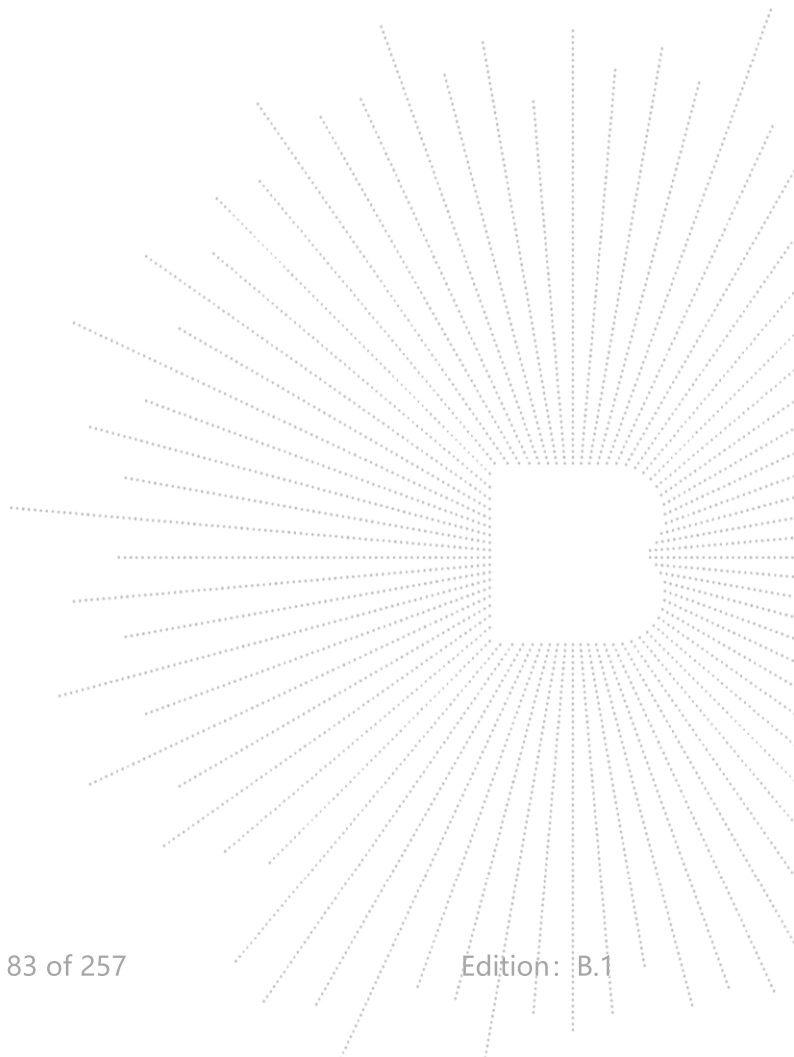

## 9.5 Test Result

|              |                |                    |              |
|--------------|----------------|--------------------|--------------|
| Temperature: | 26 °C          | Relative Humidity: | 54%          |
| Pressure:    | 101KPa         | Test Voltage:      | AC 120V/60Hz |
| Test Mode:   | (5180-5240MHz) |                    |              |

| Condition | Mode | Frequency (MHz) | -26 dB Bandwidth (MHz) |        | 99% OBW (MHz) |        | Verdict |
|-----------|------|-----------------|------------------------|--------|---------------|--------|---------|
|           |      |                 | Ant A                  | Ant B  | Ant A         | Ant B  |         |
| NVNT      | a    | 5180            | 18.718                 | 18.589 | 16.343        | 16.334 | Pass    |
| NVNT      | a    | 5200            | 18.822                 | 18.636 | 16.353        | 16.331 | Pass    |
| NVNT      | a    | 5240            | 18.564                 | 18.694 | 16.332        | 16.366 | Pass    |
| NVNT      | n20  | 5180            | 19.455                 | 19.497 | 17.547        | 17.527 | Pass    |
| NVNT      | n20  | 5200            | 19.538                 | 19.556 | 17.535        | 17.542 | Pass    |
| NVNT      | n20  | 5240            | 19.487                 | 19.534 | 17.523        | 17.542 | Pass    |
| NVNT      | n40  | 5190            | 42.512                 | 42.446 | 36.041        | 36.048 | Pass    |
| NVNT      | n40  | 5230            | 42.089                 | 42.13  | 36.01         | 36.006 | Pass    |
| NVNT      | ac20 | 5180            | 19.482                 | 19.496 | 17.539        | 17.531 | Pass    |
| NVNT      | ac20 | 5200            | 19.522                 | 19.55  | 17.533        | 17.518 | Pass    |
| NVNT      | ac20 | 5240            | 19.448                 | 19.632 | 17.547        | 17.521 | Pass    |
| NVNT      | ac40 | 5190            | 42.033                 | 41.898 | 36.103        | 36.067 | Pass    |
| NVNT      | ac40 | 5230            | 42.292                 | 41.657 | 36.065        | 36.088 | Pass    |
| NVNT      | ac80 | 5210            | <b>81.375</b>          | 80.842 | <b>74.728</b> | 74.687 | Pass    |

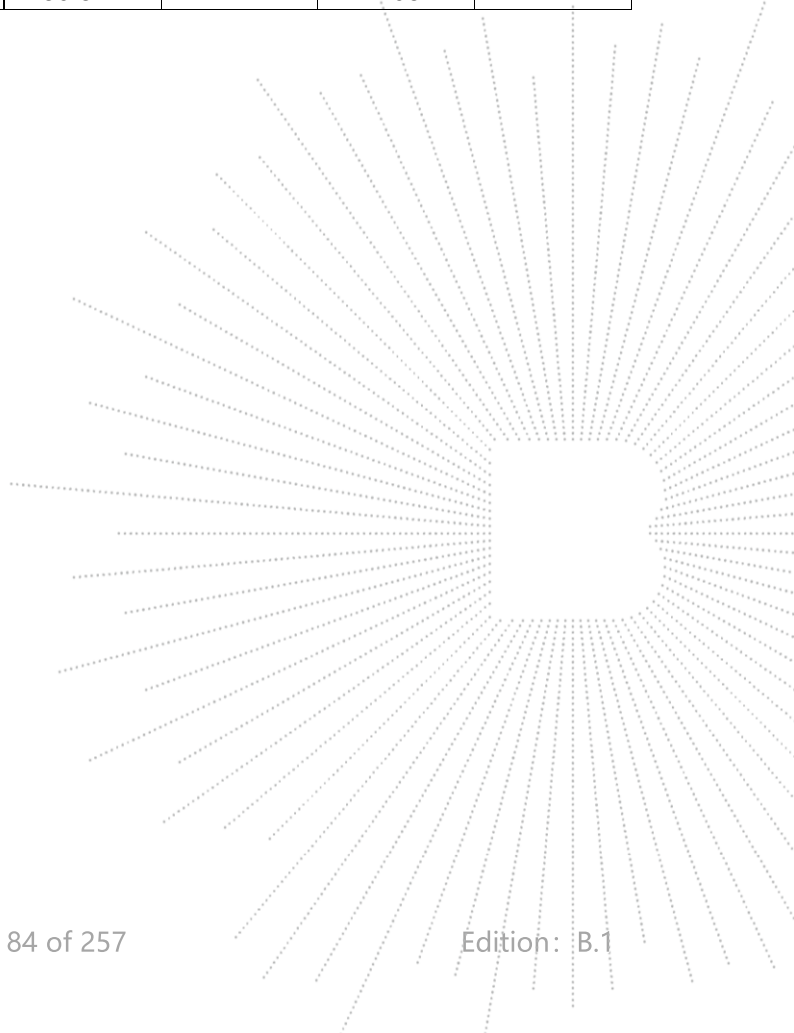

Note: A(B) Represent the value of antenna A and B, The worst data is Antenna A, only shown Antenna A Plot.

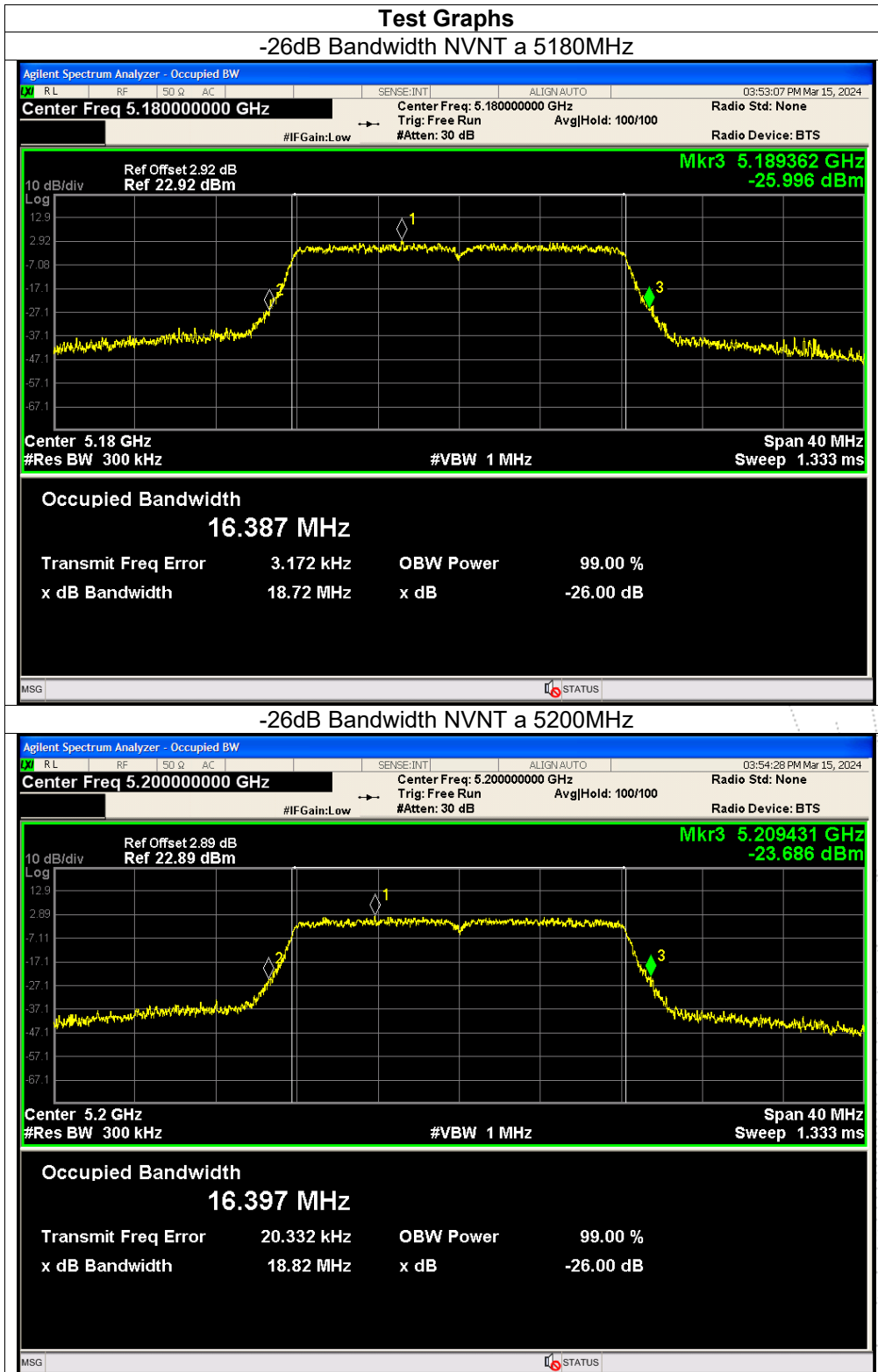

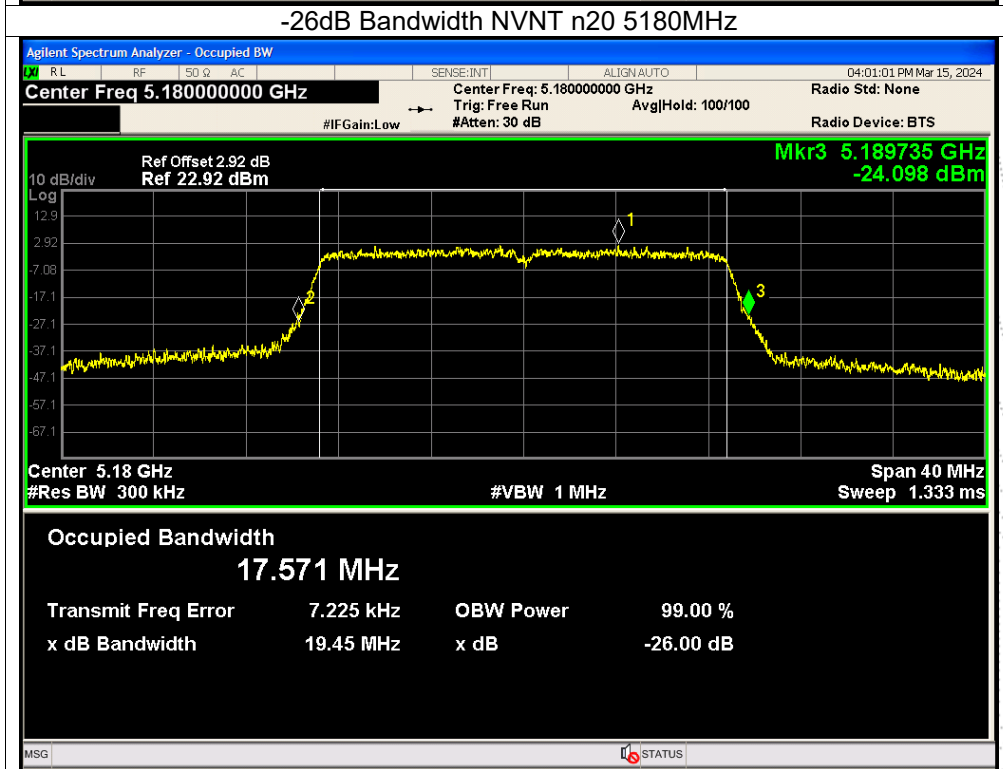
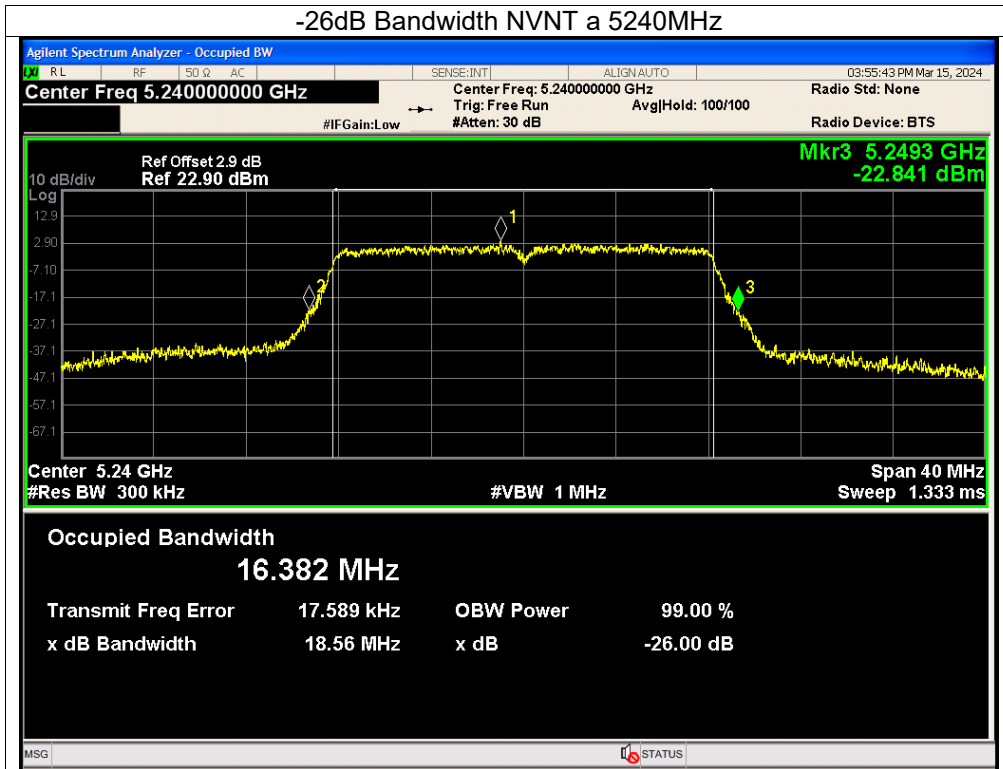

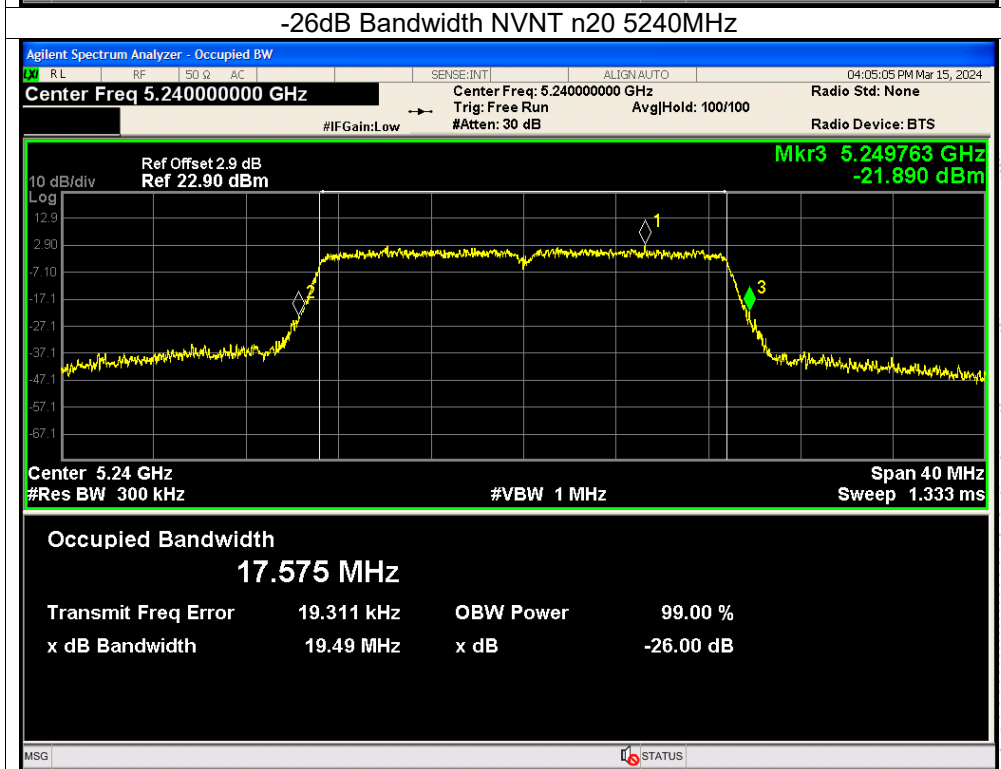
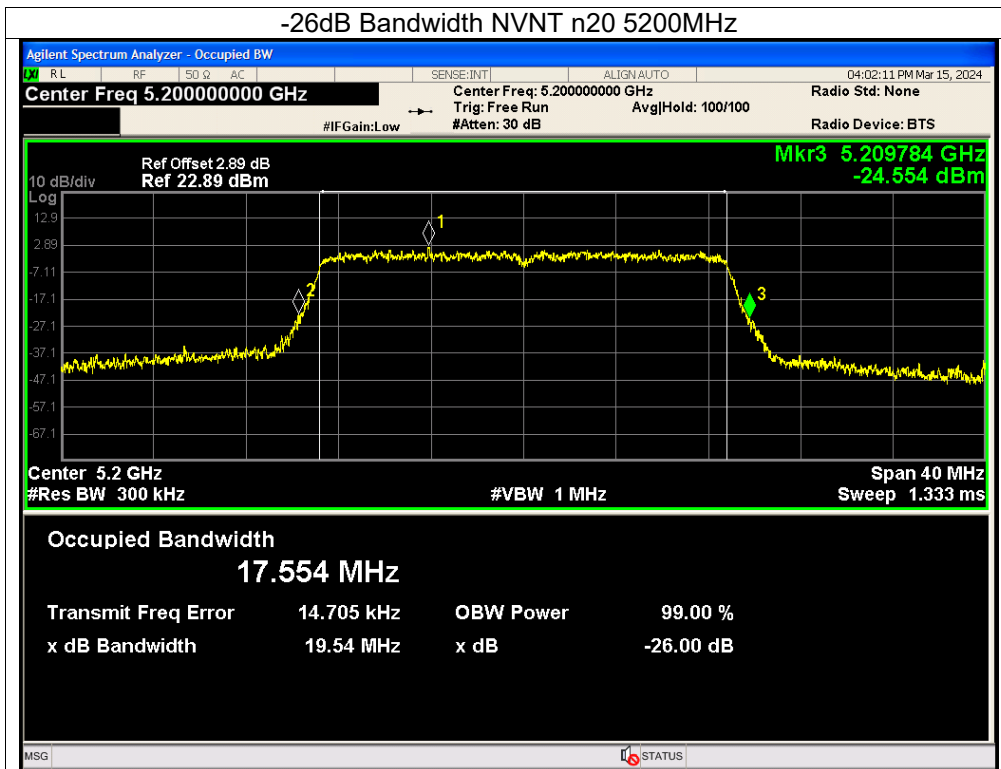

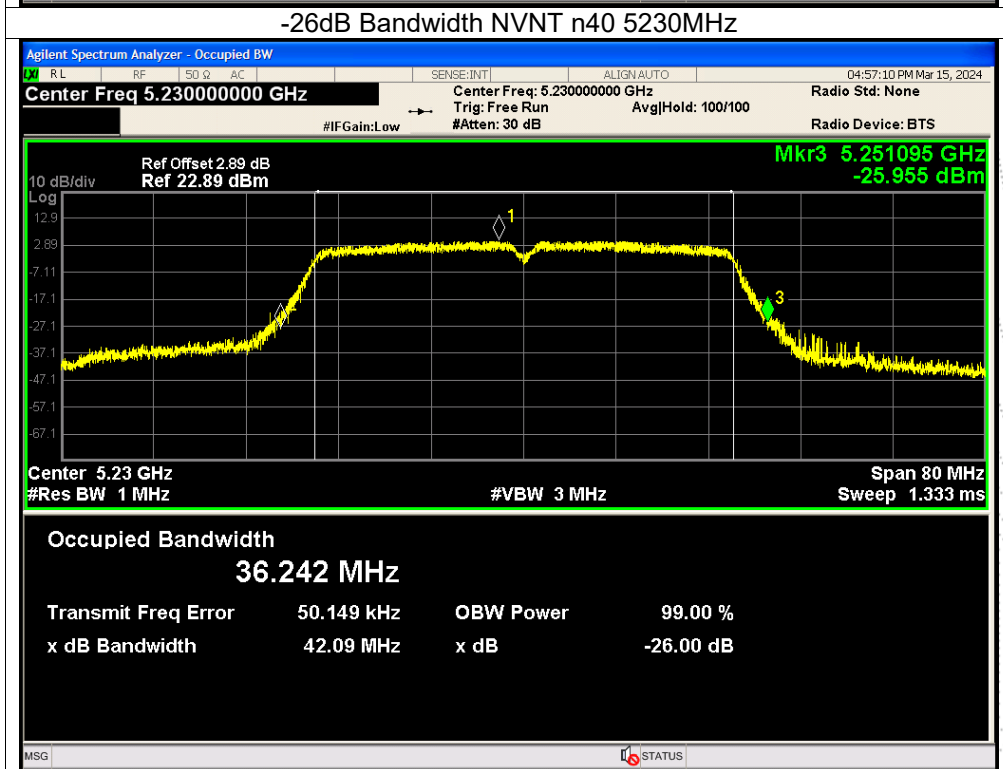
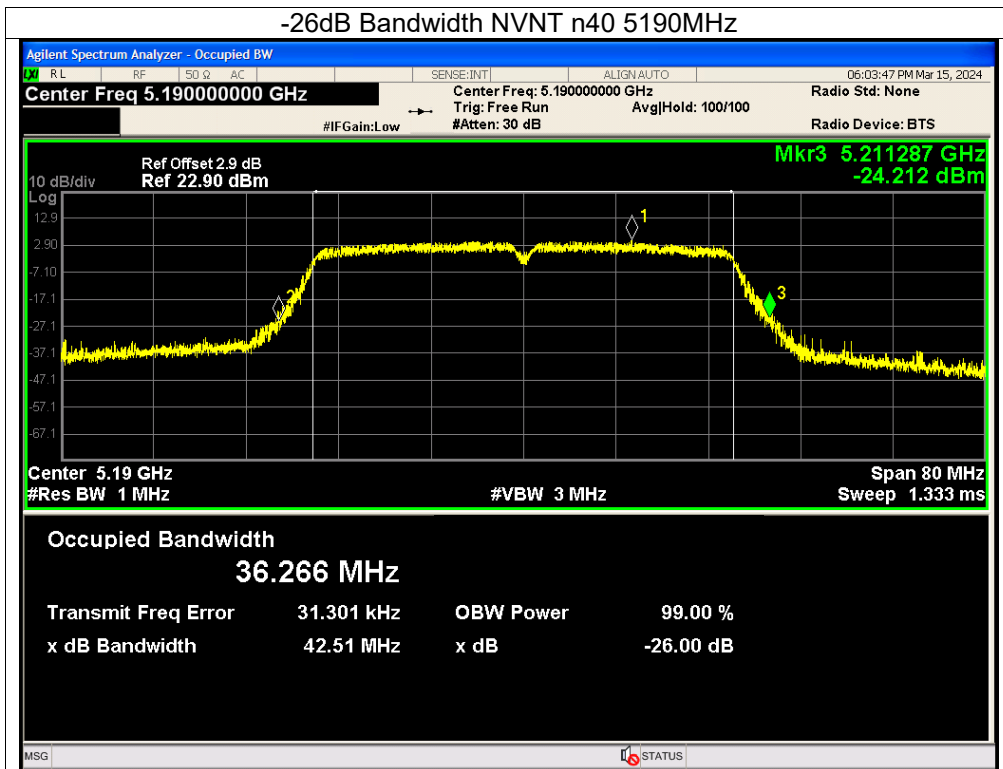



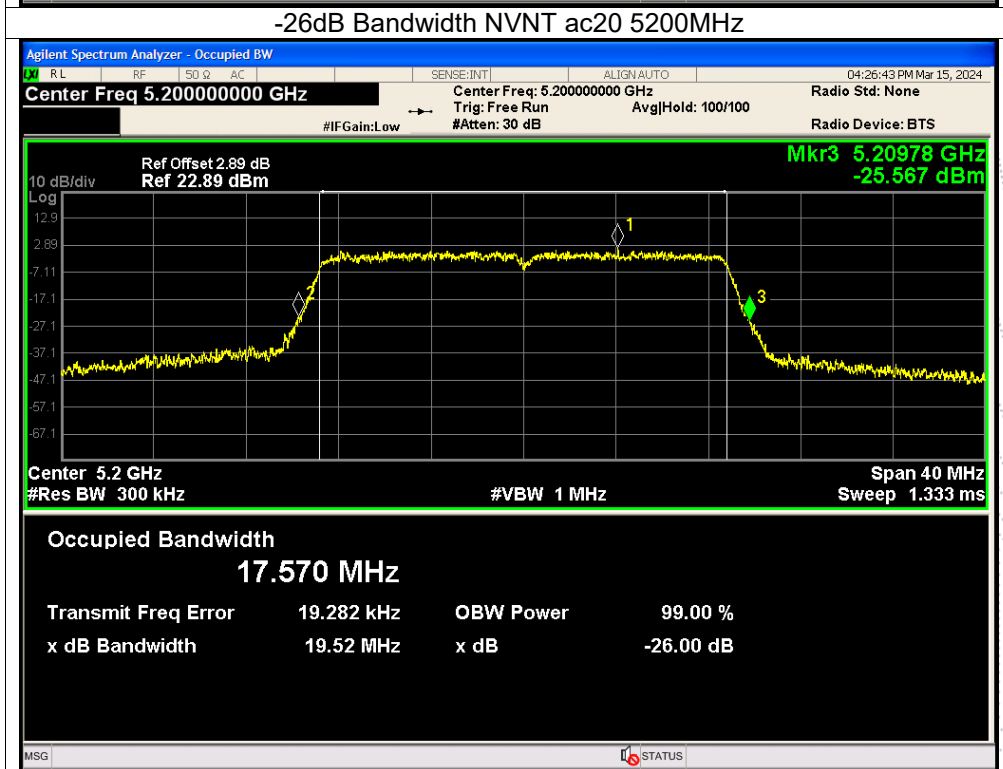
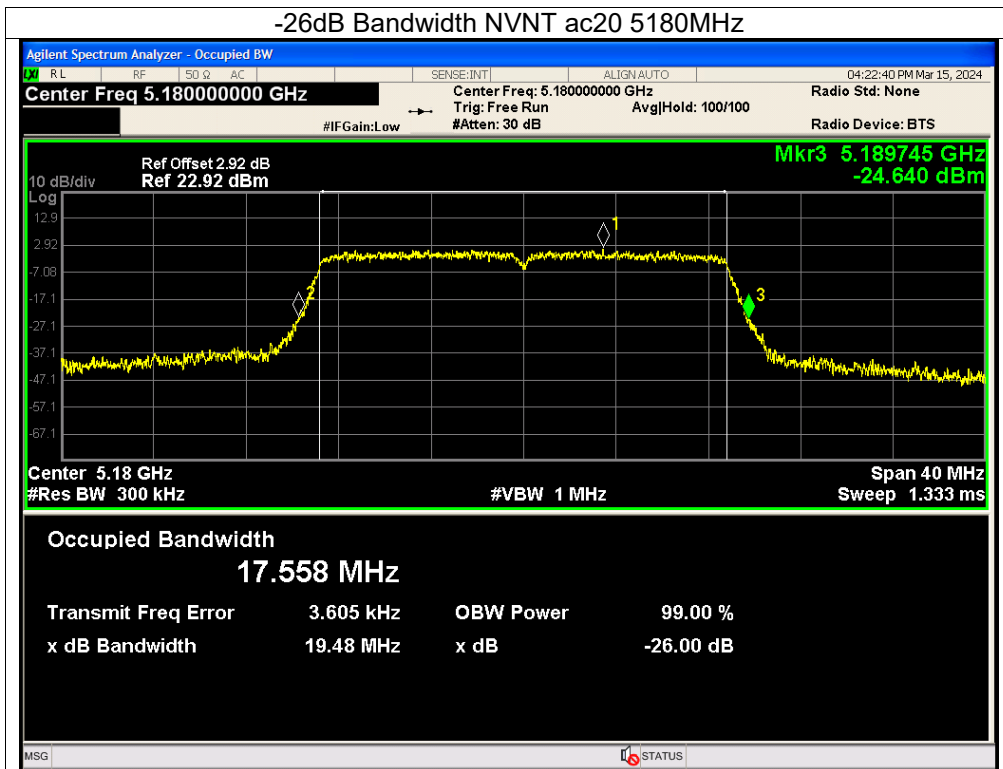

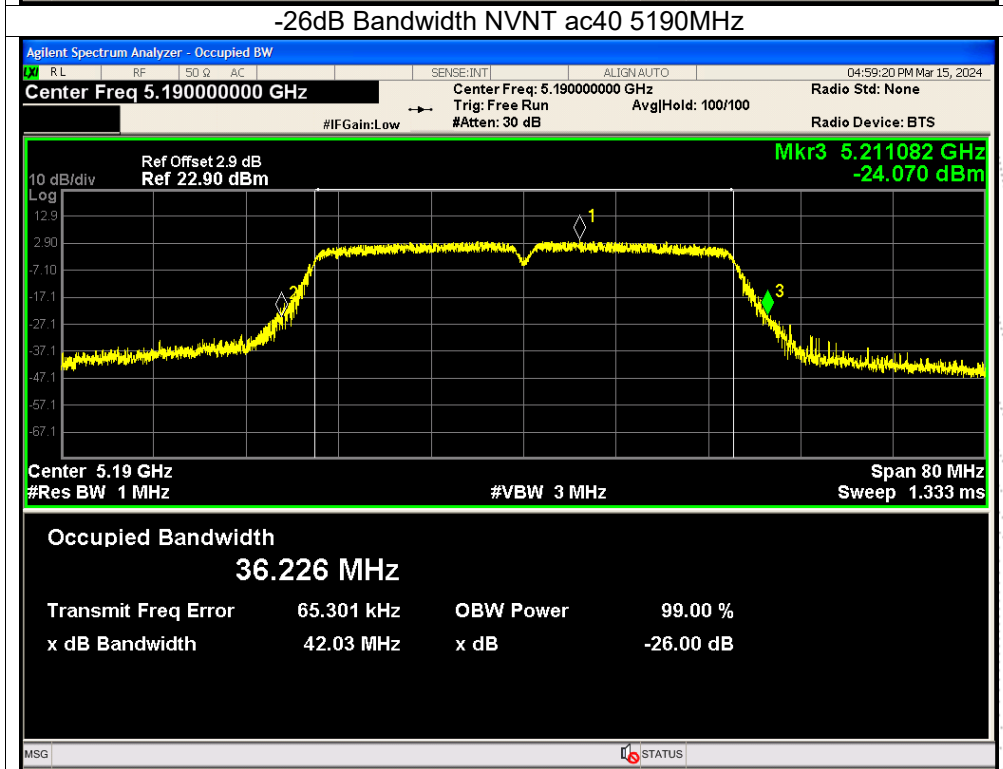
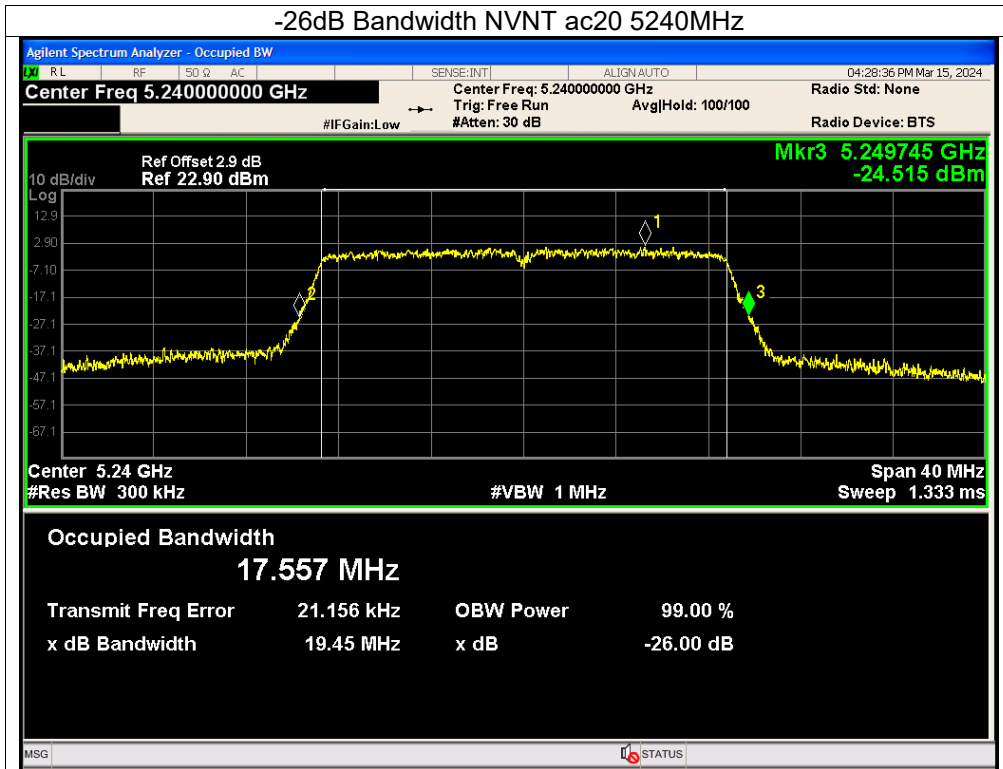

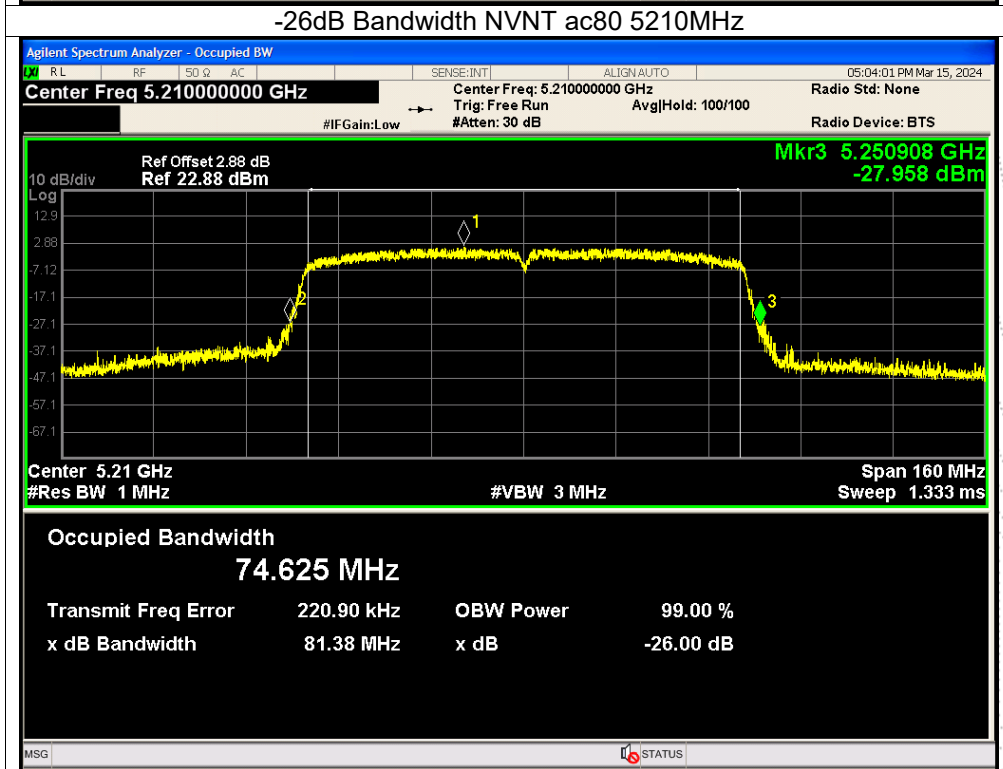
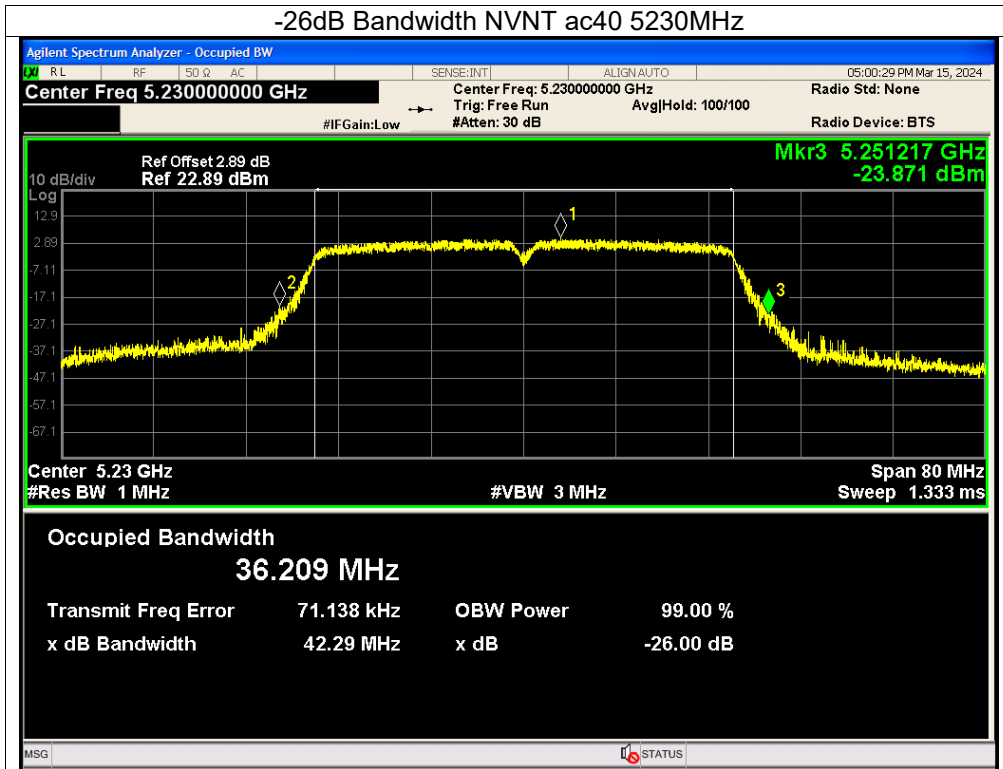

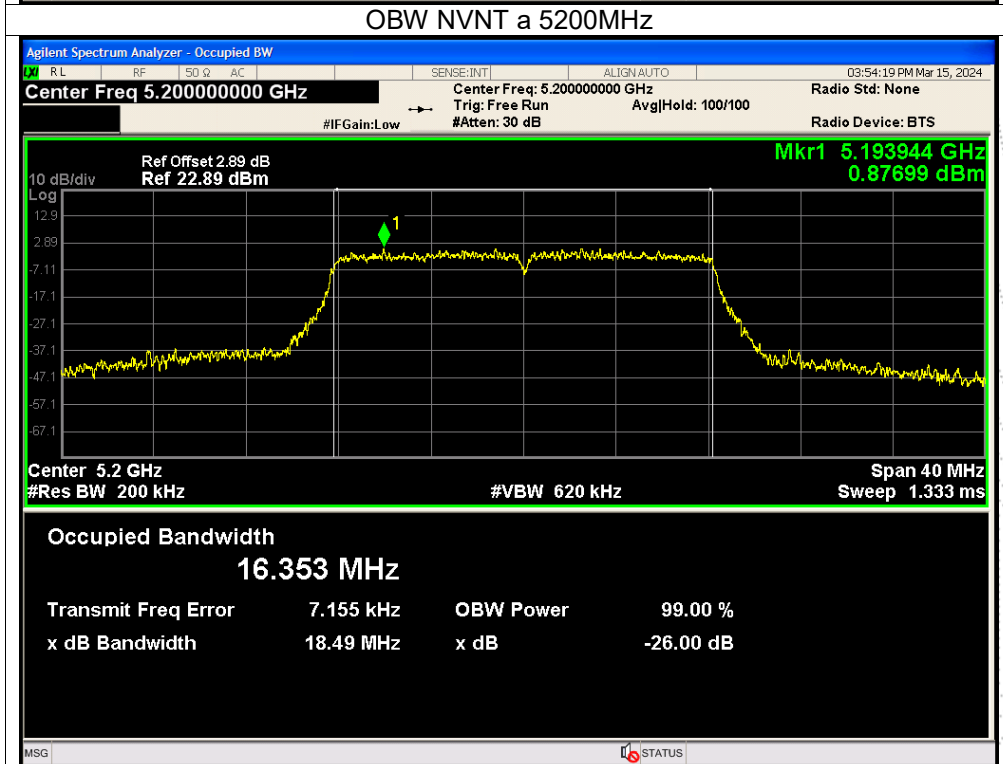
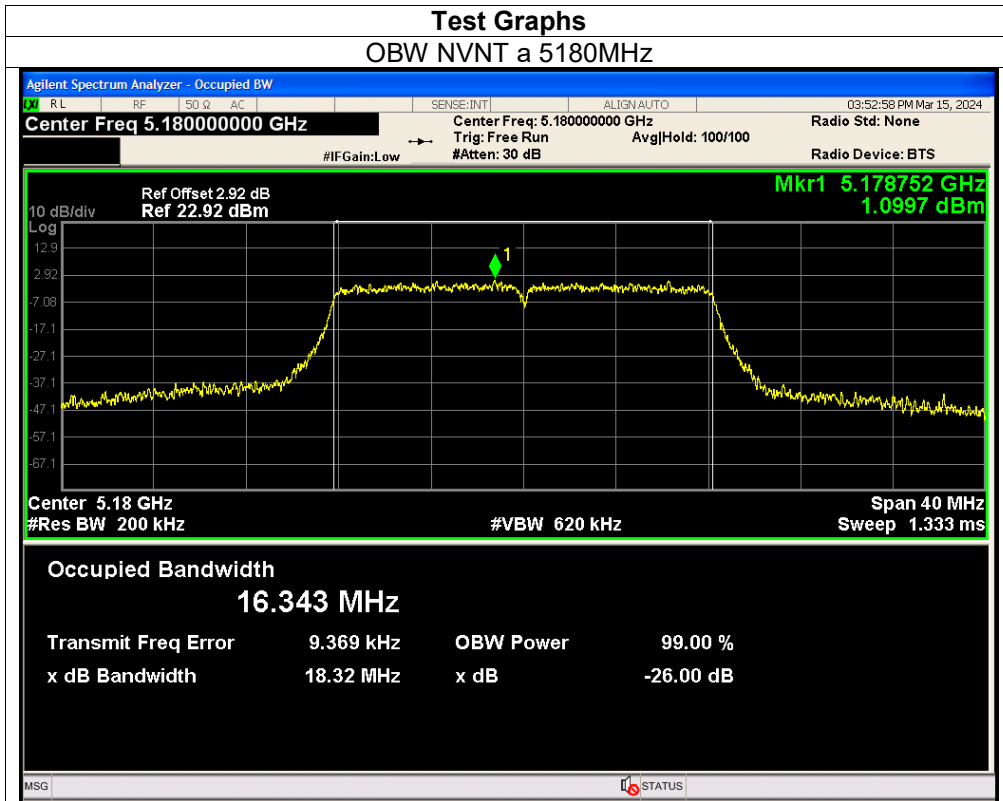

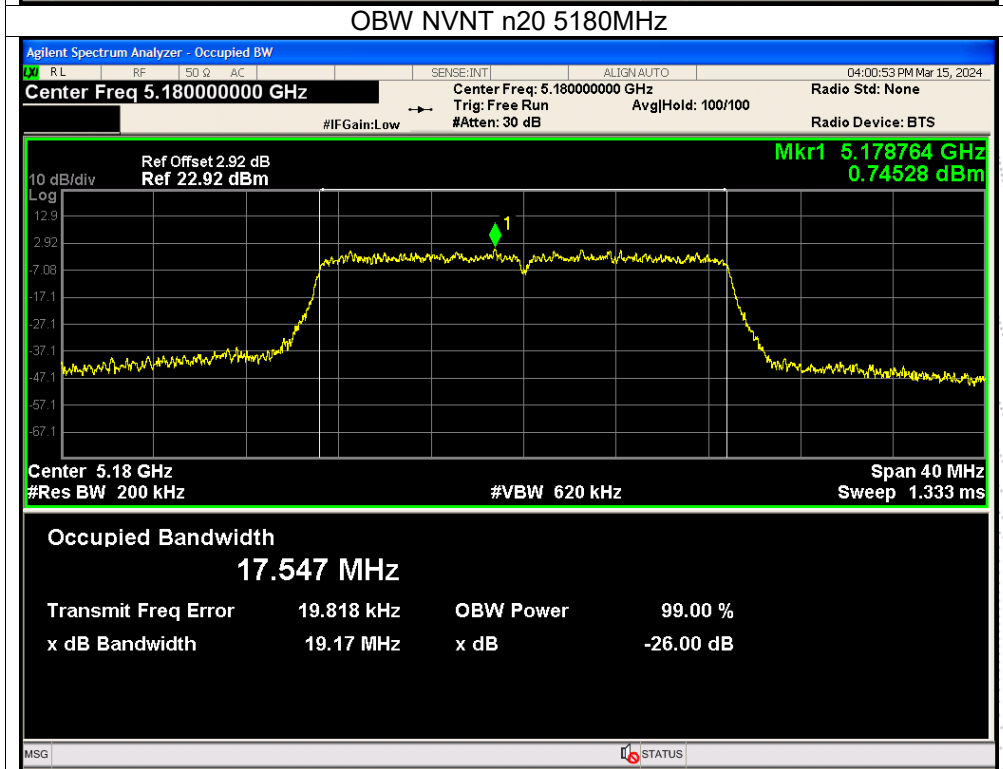
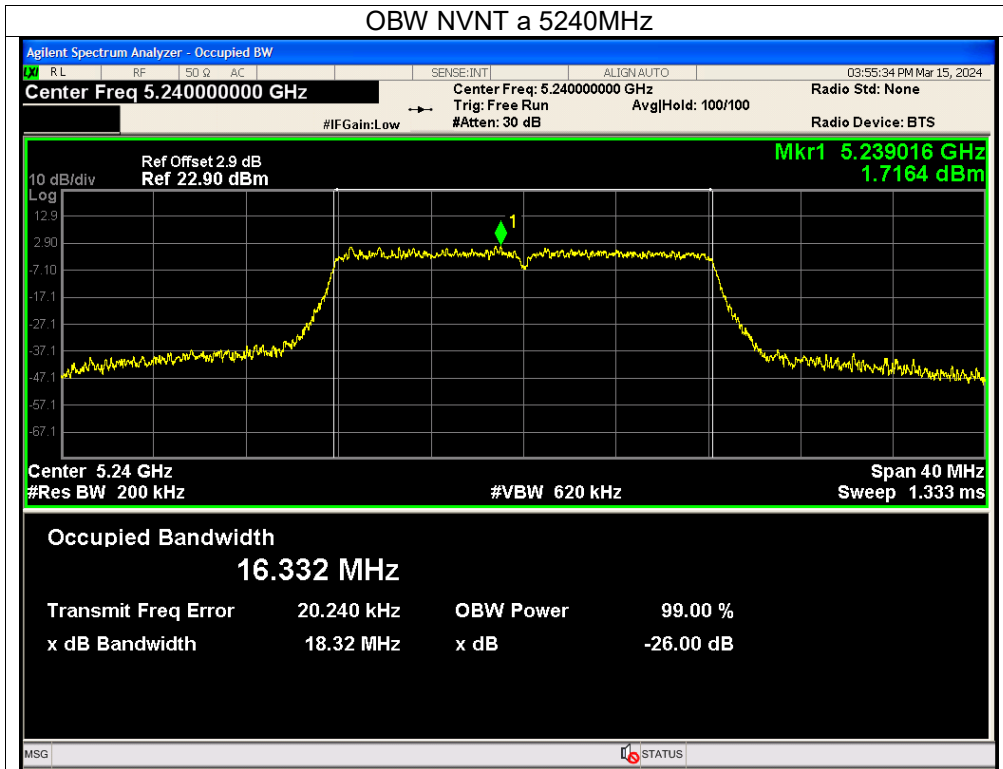

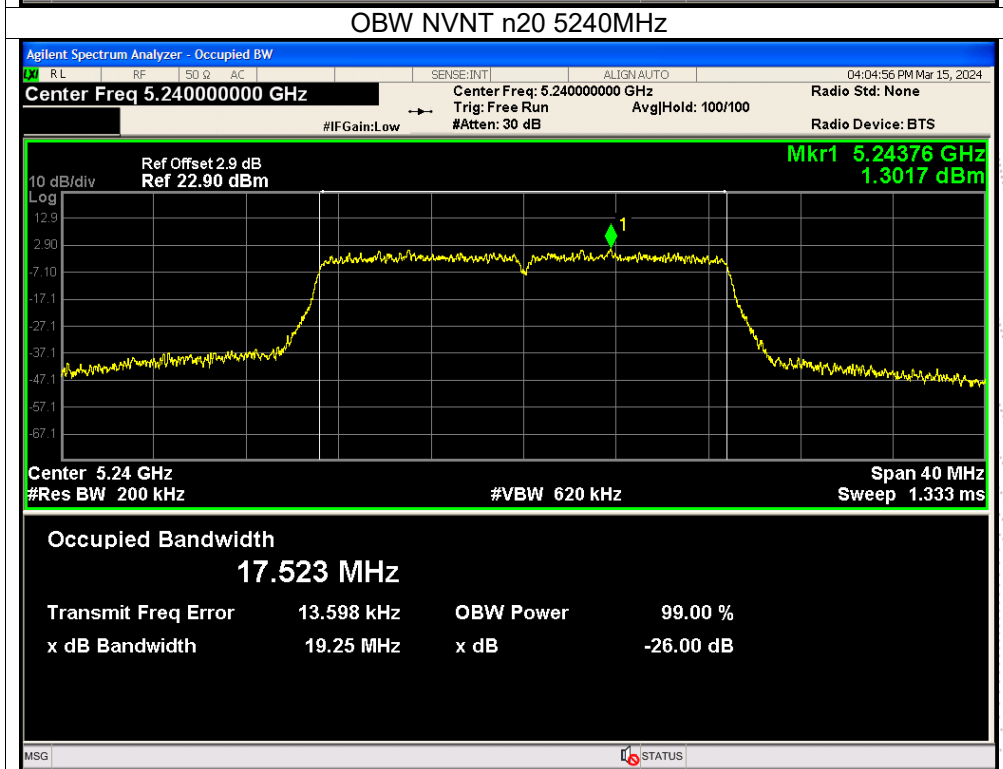
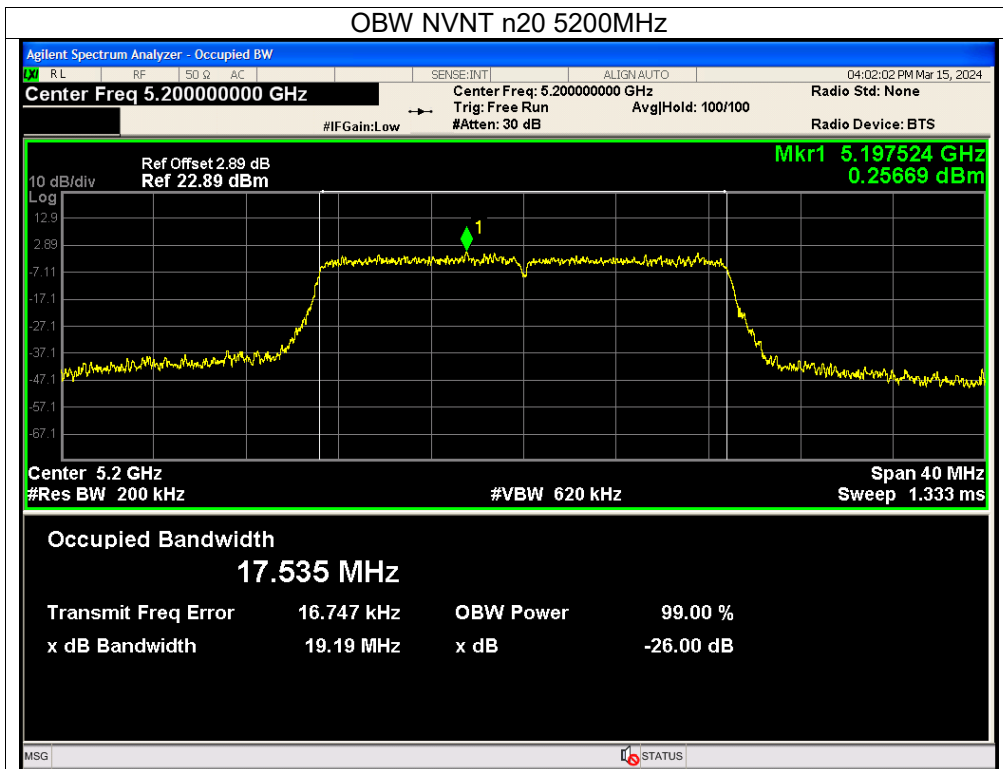

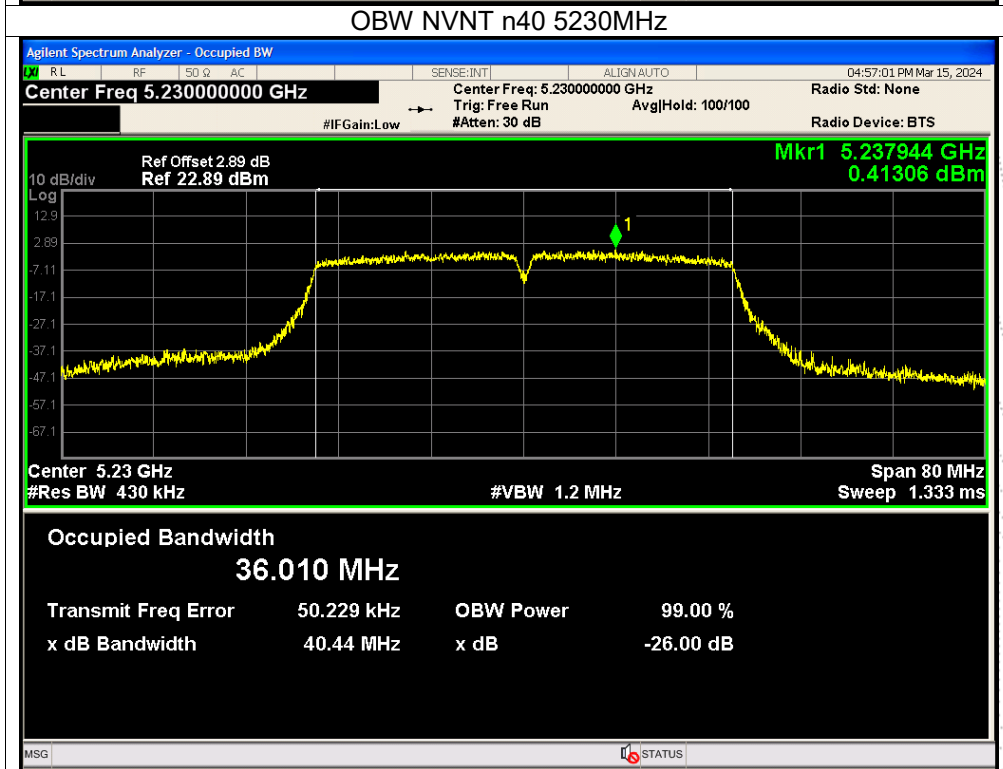
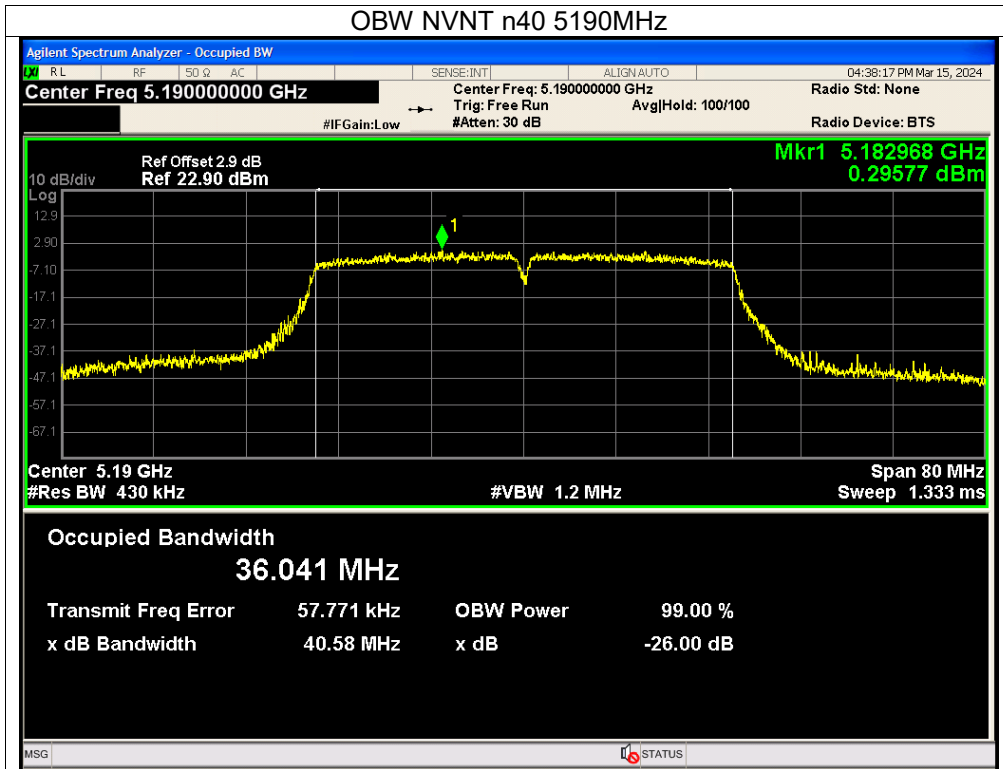

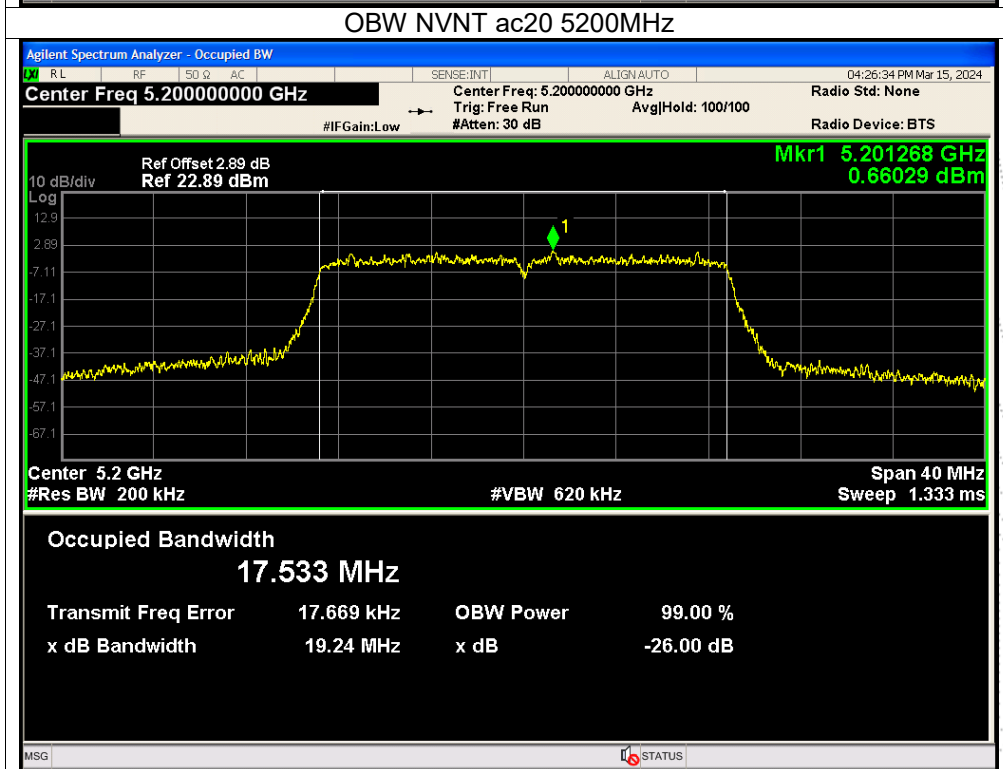
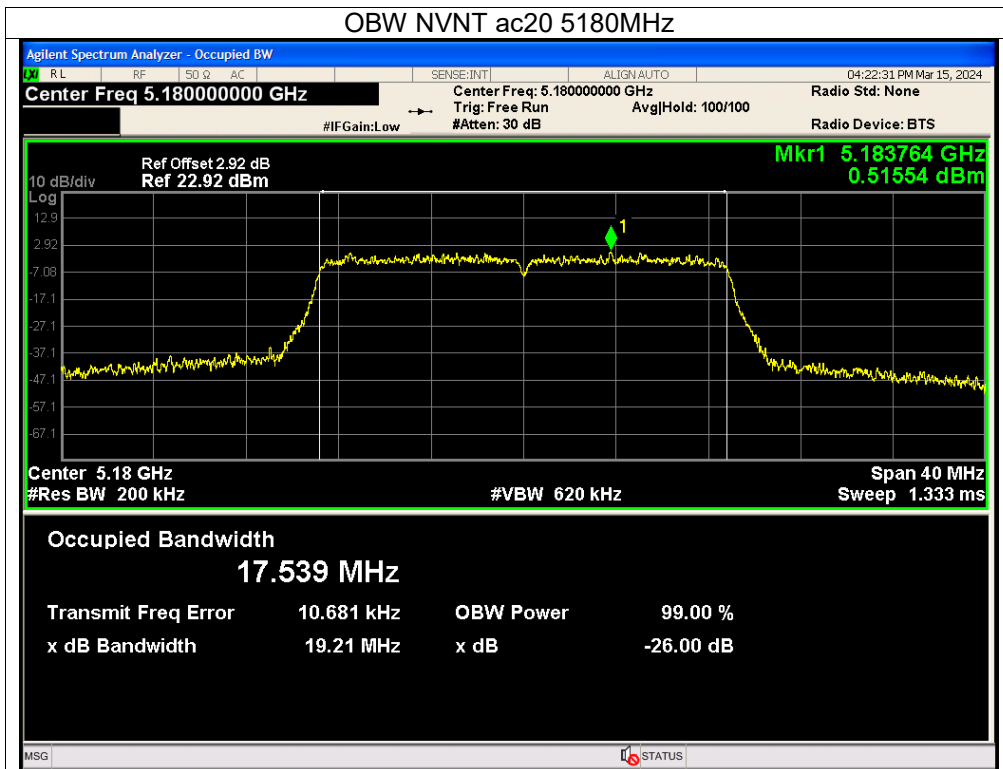



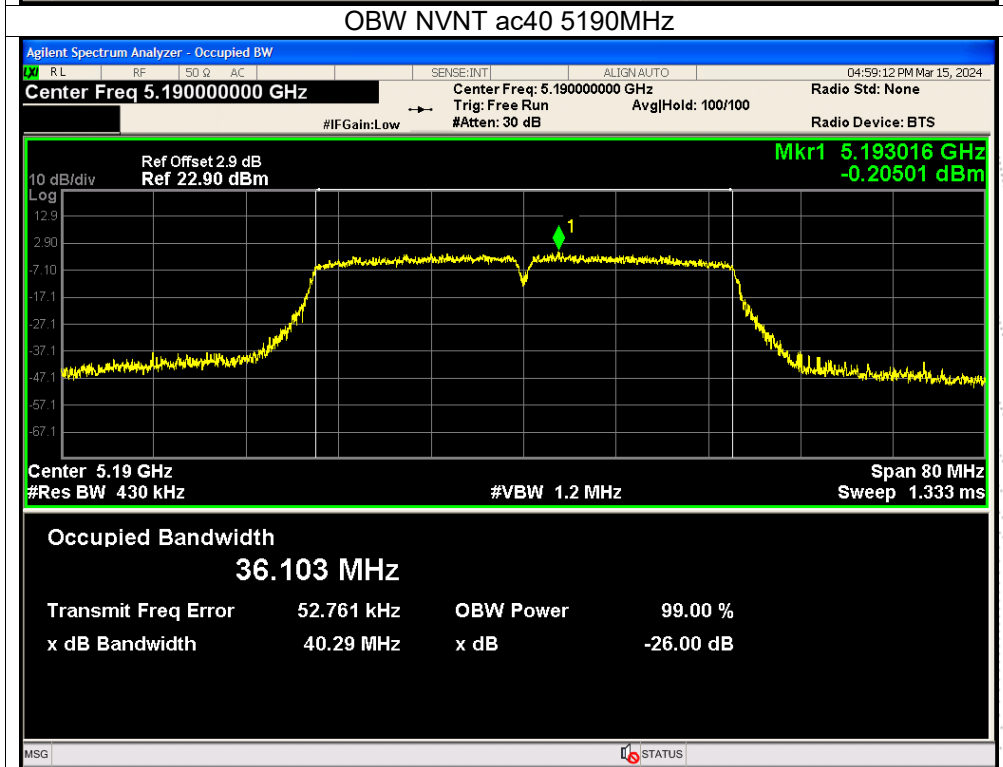
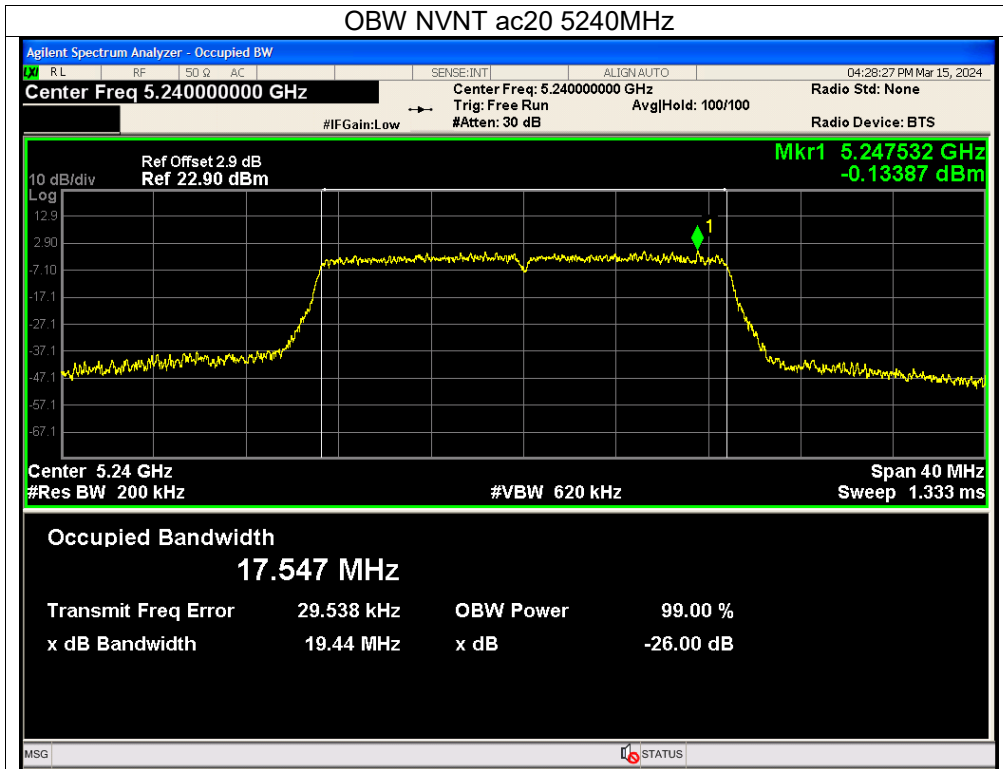

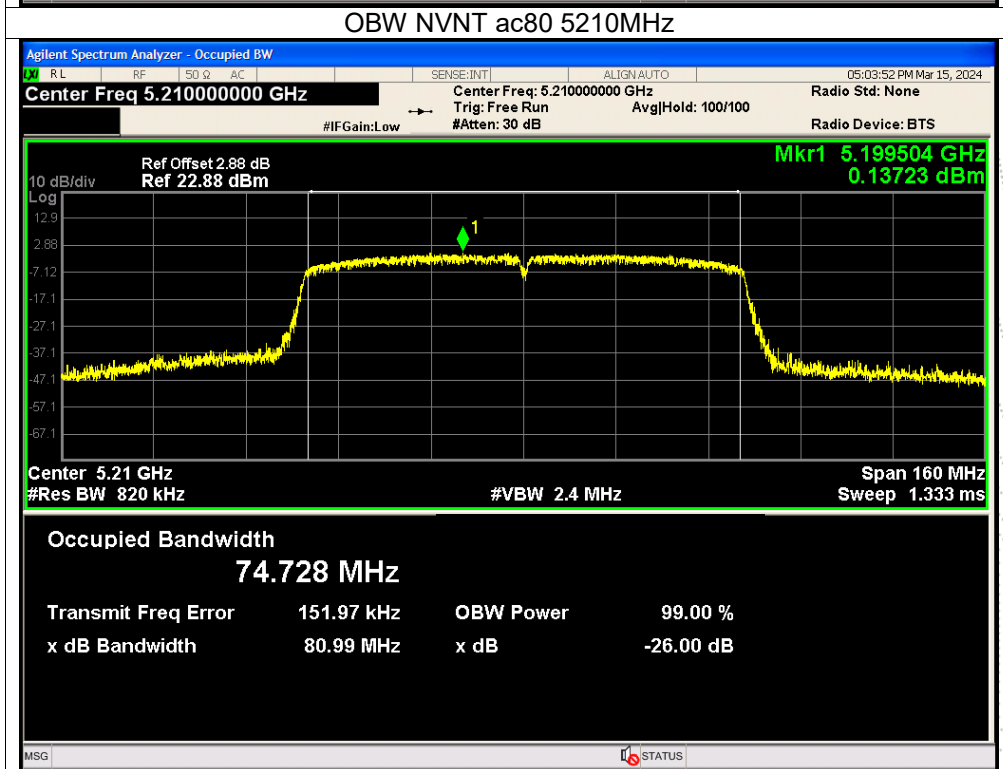
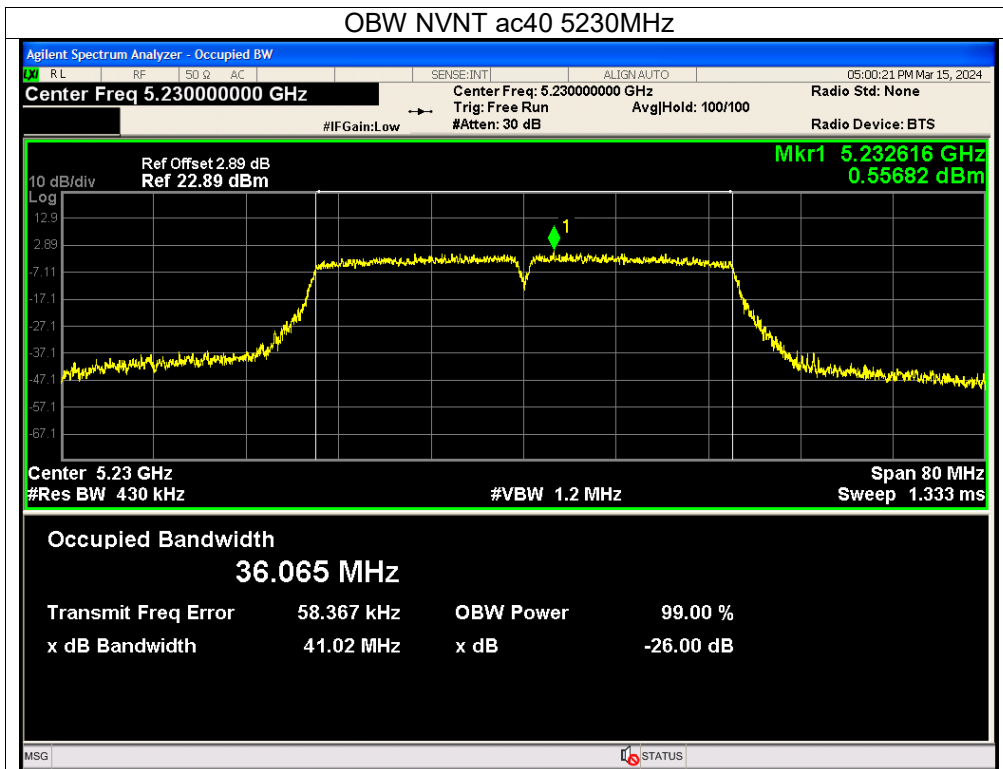

|              |                |                    |              |
|--------------|----------------|--------------------|--------------|
| Temperature: | 26 °C          | Relative Humidity: | 54%          |
| Pressure:    | 101KPa         | Test Voltage:      | AC 120V/60Hz |
| Test Mode:   | (5260-5320MHz) |                    |              |

| Condition | Mode | Frequency (MHz) | -26 dB Bandwidth (MHz) |               | 99% OBW (MHz) |        | Verdict |
|-----------|------|-----------------|------------------------|---------------|---------------|--------|---------|
|           |      |                 | Ant A                  | Ant B         | Ant A         | Ant B  |         |
| NVNT      | a    | 5260            | 18.547                 | 18.716        | 16.353        | 16.342 | Pass    |
| NVNT      | a    | 5280            | 18.674                 | 18.588        | 16.35         | 16.335 | Pass    |
| NVNT      | a    | 5320            | 18.702                 | 18.678        | 16.344        | 16.366 | Pass    |
| NVNT      | n20  | 5260            | 19.513                 | 19.531        | 17.522        | 17.534 | Pass    |
| NVNT      | n20  | 5280            | 19.561                 | 19.567        | 17.53         | 17.531 | Pass    |
| NVNT      | n20  | 5320            | 19.395                 | 19.5          | 17.535        | 17.541 | Pass    |
| NVNT      | n40  | 5270            | 39.552                 | 40.268        | 36.01         | 36.001 | Pass    |
| NVNT      | n40  | 5310            | 39.567                 | 40.275        | 36.113        | 35.997 | Pass    |
| NVNT      | ac20 | 5260            | 19.569                 | 19.576        | 17.54         | 17.532 | Pass    |
| NVNT      | ac20 | 5280            | 19.33                  | 19.555        | 17.511        | 17.529 | Pass    |
| NVNT      | ac20 | 5320            | 19.583                 | 19.579        | 17.537        | 17.521 | Pass    |
| NVNT      | ac40 | 5270            | 40.297                 | 39.92         | 36.045        | 36.006 | Pass    |
| NVNT      | ac40 | 5310            | 40.833                 | 39.687        | 36.094        | 36.026 | Pass    |
| NVNT      | ac80 | 5290            | 79.262                 | <b>79.324</b> | <b>74.886</b> | 74.509 | Pass    |

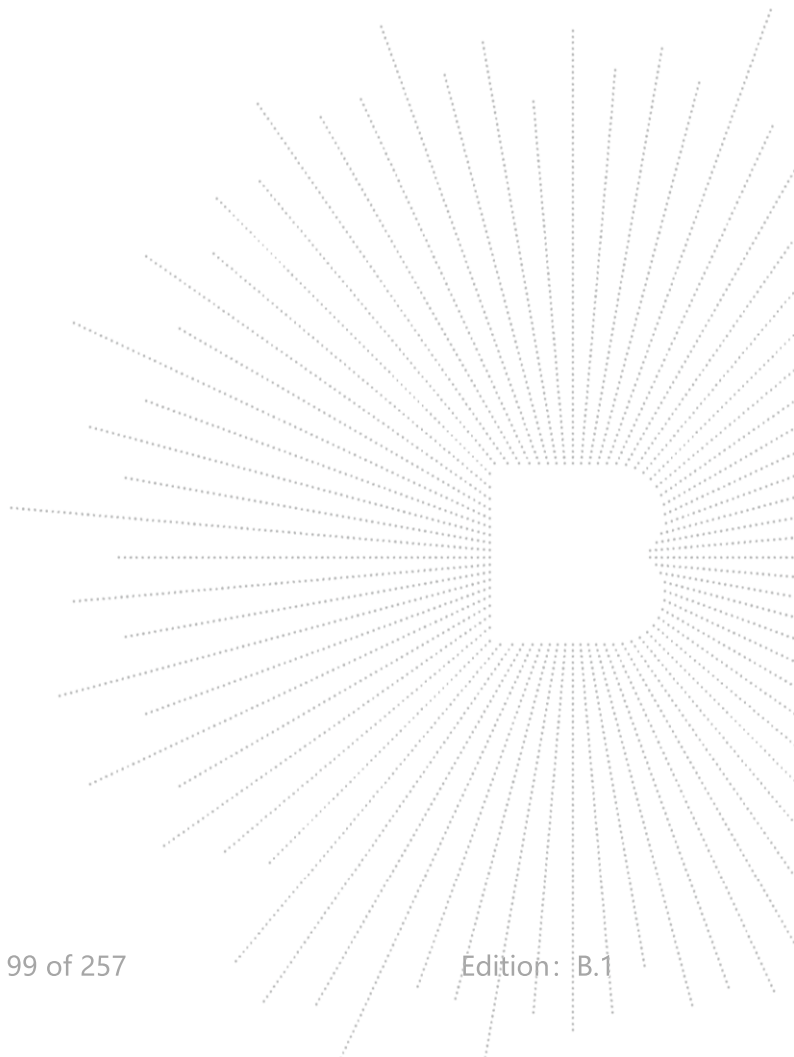

Note: A(B) Represent the value of antenna A and B, The worst data is Antenna B, only shown Antenna B Plot.

